

Welcome to E-XFL.COM

What is "[Embedded - Microcontrollers](#)"?

"[Embedded - Microcontrollers](#)" refer to small, integrated circuits designed to perform specific tasks within larger systems. These microcontrollers are essentially compact computers on a single chip, containing a processor core, memory, and programmable input/output peripherals. They are called "embedded" because they are embedded within electronic devices to control various functions, rather than serving as standalone computers. Microcontrollers are crucial in modern electronics, providing the intelligence and control needed for a wide range of applications.

Applications of "[Embedded - Microcontrollers](#)"

Details

Product Status	Active
Core Processor	PIC
Core Size	8-Bit
Speed	48MHz
Connectivity	I ² C, SPI, UART/USART, USB
Peripherals	Brown-out Detect/Reset, DMA, POR, PWM, WDT
Number of I/O	16
Program Memory Size	32KB (16K x 16)
Program Memory Type	FLASH
EEPROM Size	-
RAM Size	3.8K x 8
Voltage - Supply (Vcc/Vdd)	2V ~ 3.6V
Data Converters	A/D 10x10b
Oscillator Type	Internal
Operating Temperature	-40°C ~ 85°C (TA)
Mounting Type	Through Hole
Package / Case	28-DIP (0.300", 7.62mm)
Supplier Device Package	28-SPDIP
Purchase URL	https://www.e-xfl.com/product-detail/microchip-technology/pic18lf25j50-i-sp

PIC18F2XJXX/4XJXX FAMILY

FIGURE 2-2: PIC18F2XJXX/4XJXX FAMILY PIN DIAGRAMS (CONTINUED)

40-Pin PDIP

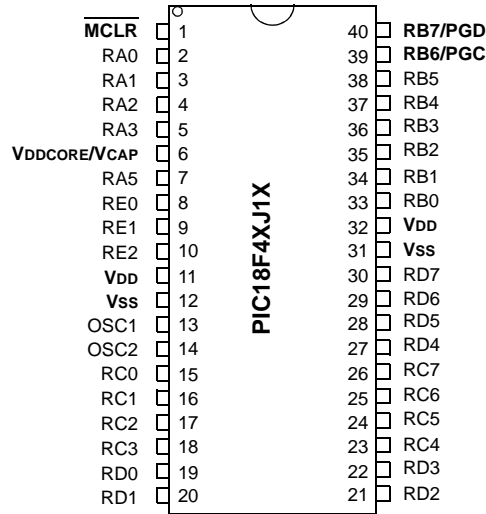

44-Pin QFN

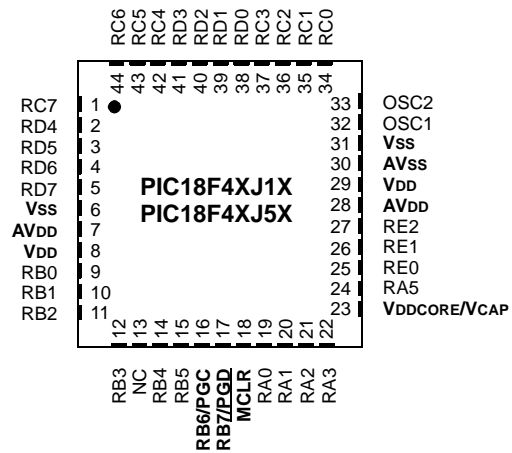

44-Pin TQFP

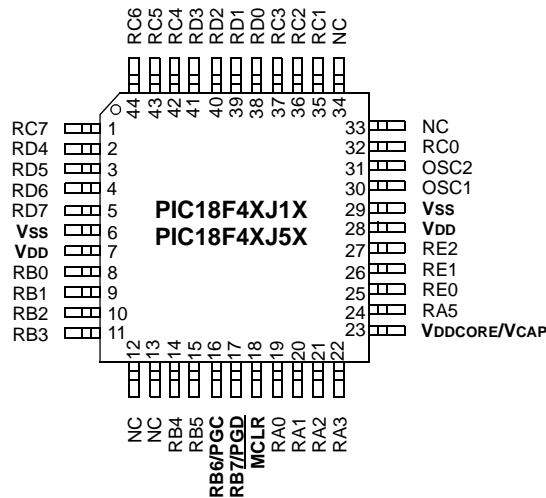

PIC18F2XJXX/4XJXX FAMILY

2.1.1 PIC18F2XJXX/4XJXX/ LF2XJXX/LF4XJXX DEVICES AND THE ON-CHIP VOLTAGE REGULATOR

PIC18FXXJXX devices have an internal core voltage regulator. On these devices (“PIC18F” in the part number), the regulator is always enabled. The regulator input is taken from the VDD pins of the microcontroller. The output of the regulator is supplied to the VDDCORE/VCAP pin. On these devices, this pin simultaneously serves as both regulator output and microcontroller core power input pin. For these devices, the VDDCORE/VCAP pin should be tied only to a capacitor.

PIC18LFXJXX devices do not have an internal core voltage regulator. On the low-voltage devices (LF), power must be externally supplied to both VDD and VDDCORE/VCAP.

Whether or not the regulator is used, it is always good design practice to have sufficient capacitance on all supply pins. Examples are shown in Figure 2-3.

The specifications for core voltage and capacitance are listed in **Section 6.0 “AC/DC Characteristics Timing Requirements for Program/Verify Test Mode”**.

FIGURE 2-3: CONNECTIONS FOR THE ON-CHIP REGULATOR

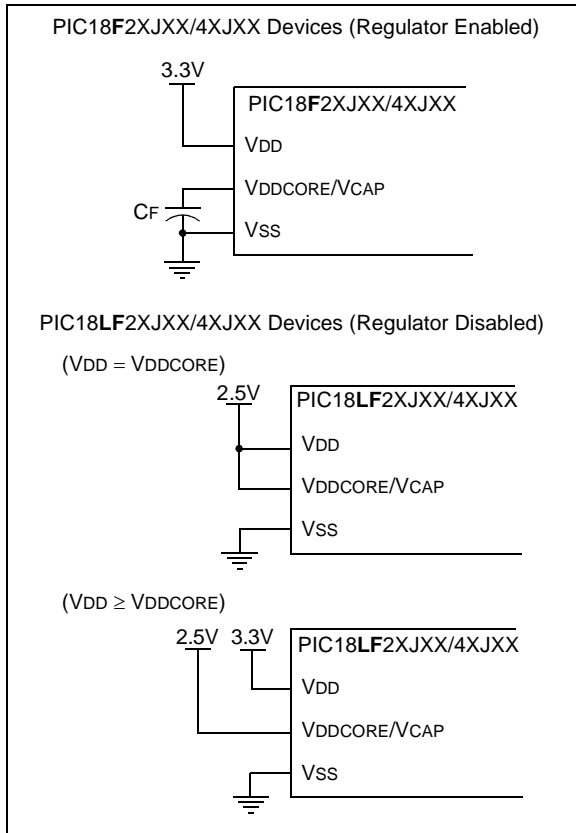

2.2 Memory Maps

The PIC18F2XJXX/4XJXX Family of devices offers program memory sizes of 16, 32, 64, and 128 Kbytes. The memory sizes for different members of the family are shown in Table 2-2. The overall memory maps for all the devices are shown in Figure 2-4.

TABLE 2-2: PROGRAM MEMORY SIZES FOR PIC18F2XJXX/4XJXX FAMILY DEVICES

Device*	Program Memory (Kbytes)	Location of Flash Configuration Words
PIC18F24J10	16	3FF8h:3FFFh
PIC18F44J10		
PIC18F24J11		
PIC18F44J11		
PIC18F24J50		
PIC18F44J50	32	7FF8h:7FFFh
PIC18F25J10		
PIC18F45J10		
PIC18F25J11		
PIC18F45J11		
PIC18F25J50	64	FFF8h:FFFFh
PIC18F45J50		
PIC18F26J11		
PIC18F46J11		
PIC18F26J13		
PIC18F46J13	128	1FFF8h:1FFFFh
PIC18F26J50		
PIC18F46J50		
PIC18F26J53		
PIC18F46J53		
PIC18F27J13	128	1FFF8h:1FFFFh
PIC18F47J13		
PIC18F27J53		
PIC18F47J53		

* Includes PIC18F and PIC18LF devices.

For purposes of code protection, the program memory for every device is treated as a single block. Therefore, enabling code protection, thus protecting the entire code memory and not individual segments.

PIC18F2XJXX/4XJXX FAMILY

The Configuration Words for these devices are located at addresses 300000h through 300007h. These are implemented as three pairs of volatile memory registers. Each register is automatically loaded from a copy stored at the end of program memory. For this reason, the last four words (or eight bytes) of the code space (also called the Flash Configuration Words) should be written with Configuration data and not executable code. The addresses of the Flash Configuration Words are listed in Table 2-2. Refer to section **Section 5.0 “Configuration Word”** for more information.

Locations 3FFFEh and 3FFFFh are reserved for the Device ID bits. These bits, which may be used by the programmer to identify what device type is being programmed, are described in **Section 5.1 “Device ID Word”**. These Device ID bits read out normally, even after code protection.

2.2.1 MEMORY ADDRESS POINTER

Memory in the device address space (000000h to 3FFFFFFh) is addressed via the Table Pointer register, which in turn is comprised of three registers:

- TBLPTRU at RAM address 0FF8h
- TBLPTRH at RAM address 0FF7h
- TBLPTRL at RAM address 0FF6h

TBLPTRU	TBLPTRH	TBLPTRL
Addr[21:16]	Addr[15:8]	Addr[7:0]

The 4-bit command, '0000' (core instruction), is used to load the Table Pointer prior to using many read or write operations.

PIC18F2XJXX/4XJXX FAMILY

FIGURE 2-4: MEMORY MAPS FOR PIC18F2XJXX/4XJXX FAMILY DEVICES⁽¹⁾

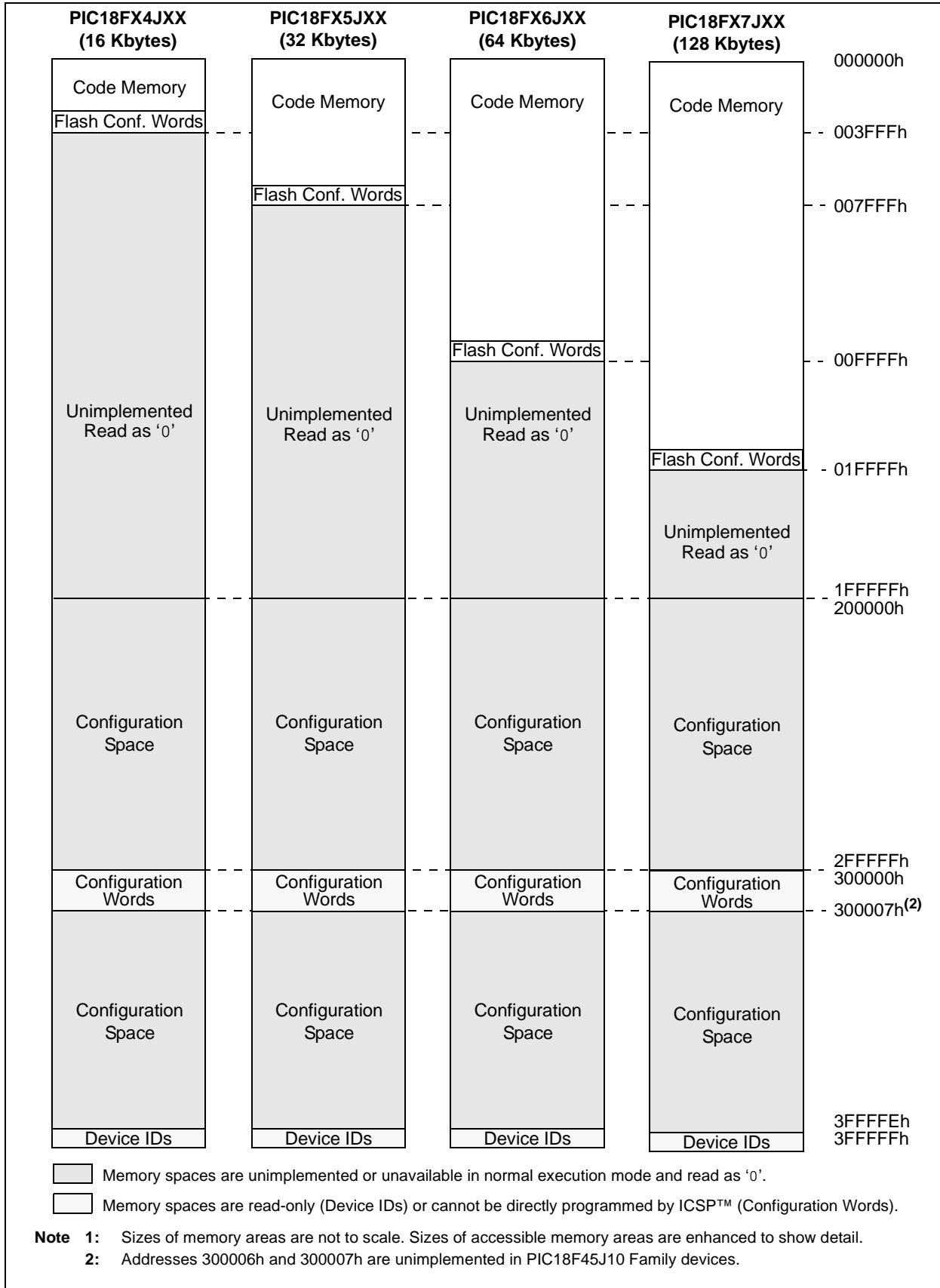

PIC18F2XJXX/4XJXX FAMILY

3.0 DEVICE PROGRAMMING

Programming includes the ability to erase or write the memory within the device.

The EECON1 register is used to control Write or Row Erase operations. The WREN bit must be set to enable writes; this must be done prior to initiating a write sequence. It is strongly recommended that the WREN bit only be set immediately prior to a program or erase operation.

The FREE bit must be set in order to erase the program space being pointed to by the Table Pointer. The erase or write sequence is initiated by setting the WR bit.

3.1 ICSP™ Erase

3.1.1 ICSP BULK ERASE

The PIC18F2XJXX/4XJXX Family devices may be Bulk Erased by writing 0180h to the table address, 3C0005h:3C0004h. The basic sequence is shown in Table 3-1 and demonstrated in Figure 3-1.

Since the code-protect Configuration bit is stored in the program code within code memory, a Bulk Erase operation will also clear any code-protect settings for the device.

The actual Bulk Erase function is a self-timed operation. Once the erase has started (falling edge of the 4th PGC after the NOP command), serial execution will cease until the erase completes (parameter P11). During this time, PGC may continue to toggle but PGD must be held low.

TABLE 3-1: BULK ERASE COMMAND SEQUENCE

4-Bit Command	Data Payload	Core Instruction
0000	0E 3C	MOVLW 3Ch
0000	6E F8	MOVWF TBLPTRU
0000	0E 00	MOVLW 00h
0000	6E F7	MOVWF TBLPTRH
0000	0E 05	MOVLW 05h
0000	6E F6	MOVWF TBLPTRL
1100	01 01	Write 01h to 3C0005h
0000	0E 3C	MOVLW 3Ch
0000	6E F8	MOVWF TBLPTRU
0000	0E 00	MOVLW 00h
0000	6E F7	MOVWF TBLPTRH
0000	0E 04	MOVLW 04h
0000	6E F6	MOVWF TBLPTRL
1100	80 80	Write 80h TO 3C0004h to erase entire device.
0000	00 00	NOP
0000	00 00	Hold PGD low until erase completes.

FIGURE 3-1: BULK ERASE FLOW

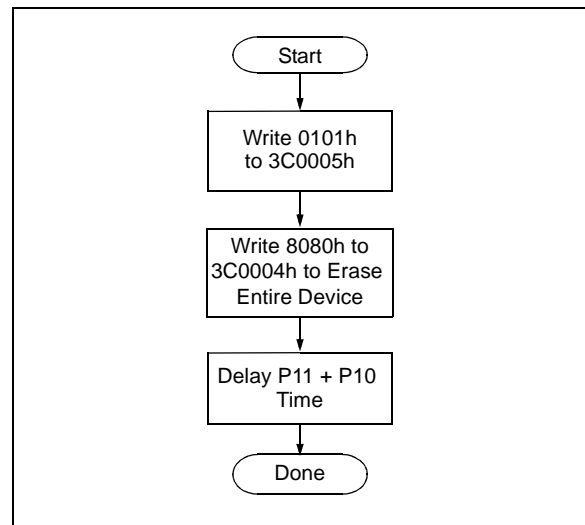
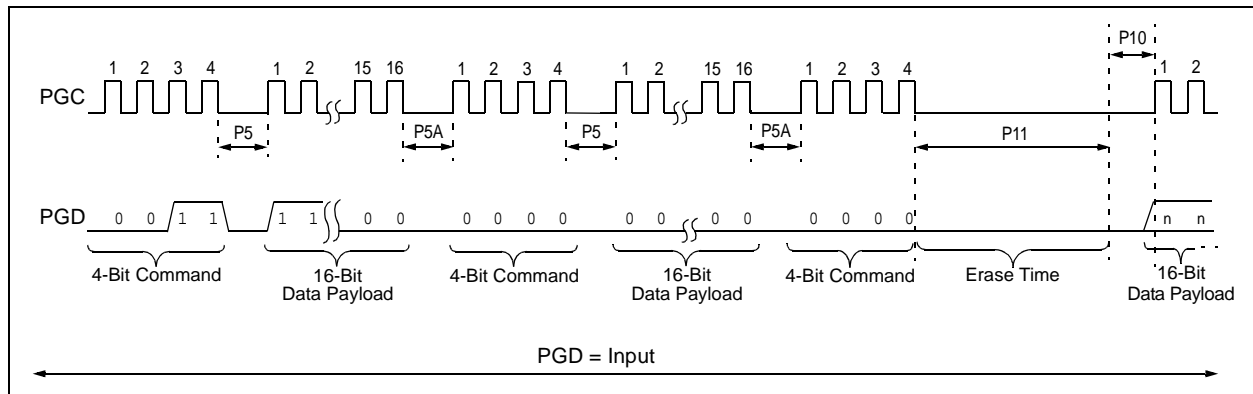

FIGURE 3-2: BULK ERASE TIMING



PIC18F2XJXX/4XJXX FAMILY

3.1.2 ICSP™ ROW ERASE

It is possible to erase one row (1024 bytes of data), provided the block is not code-protected or erase/write-protected. Rows are located at static boundaries beginning at program memory address 000000h, extending to the internal program memory limit. Refer to **Section 2.2 “Memory Maps”**).

The Row Erase duration is internally timed. After the WR bit in EECON1 is set, a NOP instruction is issued, where the 4th PGC is held high for the duration of the Row Erase time, P10.

The code sequence to Row Erase a PIC18F2XJXX/4XJXX Family device is shown in Table 3-2. The flowchart shown in Figure 3-4 depicts the logic necessary to completely erase a PIC18F2XJXX/4XJXX

Family device. The timing diagram that details the Row Erase command and parameter P10 is shown in Figure 3-3.

- Note 1:** If the last row of program memory is erased, bit 3 of CONFIG1H must also be programmed as '0'.
- 2:** The TBLPTR register can point at any byte within the row intended for erase.
- 3:** If code protection has been enabled, ICSP Bulk Erase (all program memory erased) operations can be used to disable code protection. ICSP Row Erase operations cannot be used to disable code protection.

TABLE 3-2: ERASE CODE MEMORY CODE SEQUENCE

4-Bit Command	Data Payload	Core Instruction
Step 1: Enable memory writes.		
0000	84 A6	BSF EECON1, WREN
Step 2: Point to first row in code memory.		
0000	6A F8	CLRF TBLPTRU
0000	6A F7	CLRF TBLPTRH
0000	6A F6	CLRF TBLPTRL
Step 3: Enable erase and erase single row.		
0000	88 A6	BSF EECON1, FREE
0000	82 A6	BSF EECON1, WR
0000	00 00	NOP - hold PGC high for time P10.
Step 4: Repeat Step 3, with Address Pointer incremented by 1024, until all rows are erased.		

FIGURE 3-3: SET WR AND START ROW ERASE TIMING

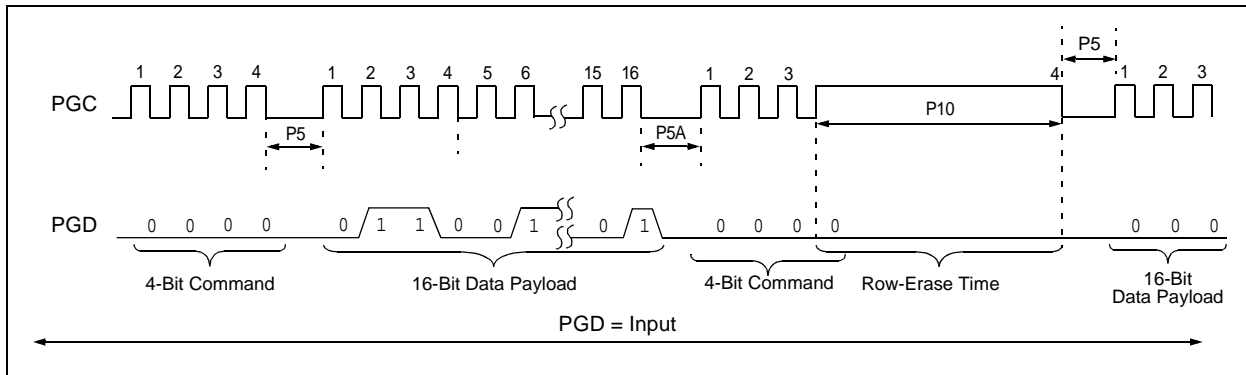

PIC18F2XJXX/4XJXX FAMILY

3.2 Code Memory Programming

Programming code memory is accomplished by first loading data into the write buffer and then initiating a programming sequence. The write buffer for all devices in the PIC18F2XJXX/4XJXX Family is 64 bytes. It can be mapped to any 64-byte block beginning at 000000h. The actual memory write sequence takes the contents of this buffer and programs the 64-byte block of code memory indicated by the Table Pointer.

Write buffer locations are not cleared following a write operation; the buffer retains its data after the write is complete. This means that the buffer must be written with 64 bytes on each operation. If there are locations in the code memory that are to remain empty, the corresponding locations in the buffer must be filled with FFFFh. This avoids rewriting old data from the previous cycle.

The programming duration is internally timed. After a Start Programming command is issued (4-bit command, '1111'), a NOP is issued, where the 4th PGC is held high for the duration of the programming time, P9.

The code sequence to program a PIC18F2XJXX/4XJXX Family device is shown in Table 3-3. The flowchart shown in Figure 3-5 depicts the logic necessary to completely write a PIC18F2XJXX/4XJXX Family device. The timing diagram that details the Start Programming command and parameter P9 is shown in Figure 3-6.

Note 1: The TBLPTR register must point to the same region when initiating the programming sequence as it did when the write buffers were loaded.

TABLE 3-3: WRITE CODE MEMORY CODE SEQUENCE

4-Bit Command	Data Payload	Core Instruction
Step 1: Enable writes.		
0000	84 A6	BSF EECON1, WREN
Step 2: Load write buffer.		
0000	0E <Addr[21:16]>	MOVLW <Addr[21:16]>
0000	6E F8	MOVWF TBLPTRU
0000	0E <Addr[15:8]>	MOVLW <Addr[15:8]>
0000	6E F7	MOVWF TBLPTRH
0000	0E <Addr[7:0]>	MOVLW <Addr[7:0]>
0000	6E F6	MOVWF TBLPTRL
Step 3: Repeat for all but the last two bytes. Any unused locations should be filled with FFFFh.		
1101	<MSB><LSB>	Write 2 bytes and post-increment address by 2.
Step 4: Load write buffer for last two bytes.		
1111	<MSB><LSB>	Write 2 bytes and start programming.
0000	00 00	NOP - hold PGC high for time P9.
To continue writing data, repeat Steps 2 through 4, where the Address Pointer is incremented by 2 at each iteration of the loop.		

PIC18F2XJXX/4XJXX FAMILY

FIGURE 3-5: PROGRAM CODE MEMORY FLOW

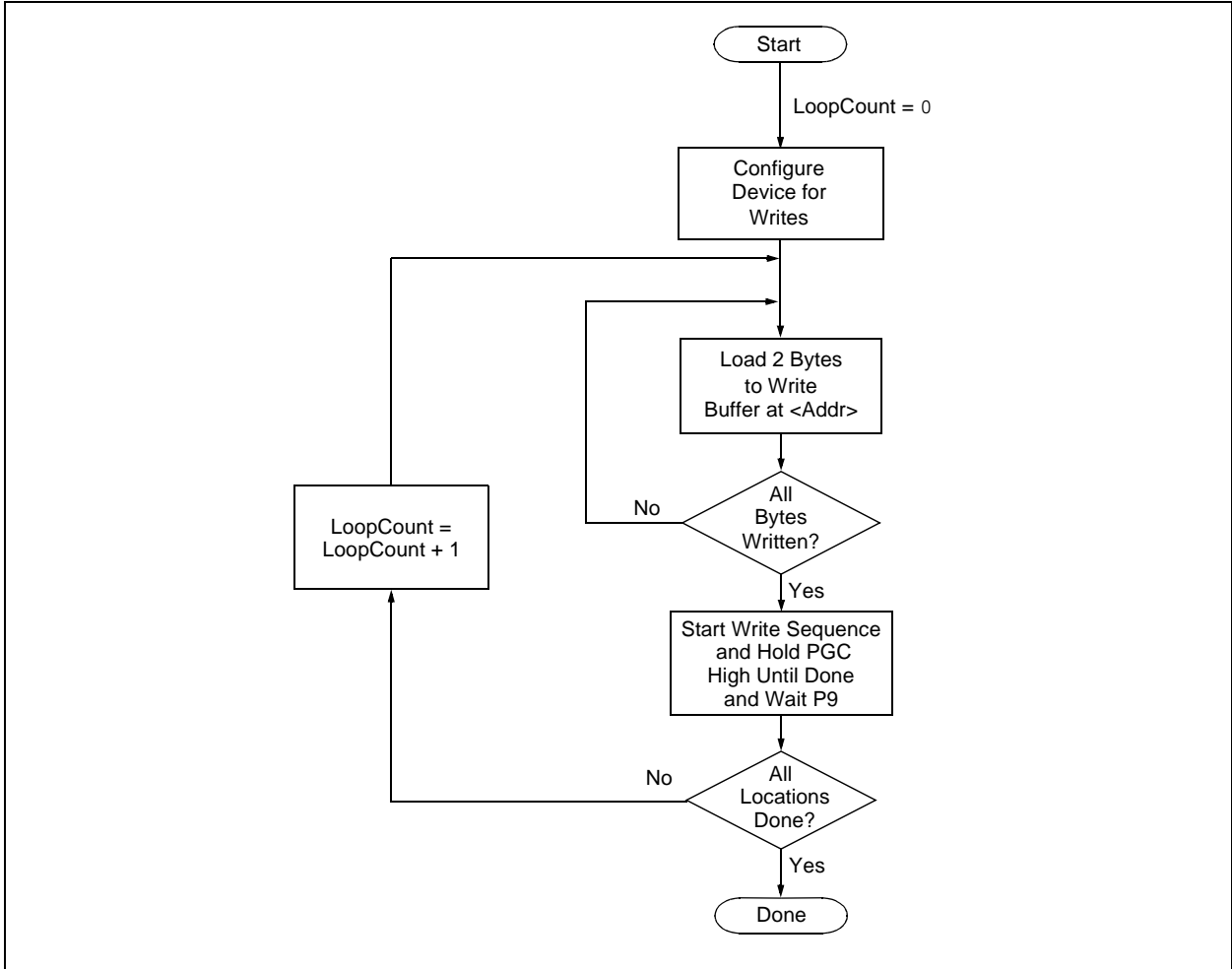
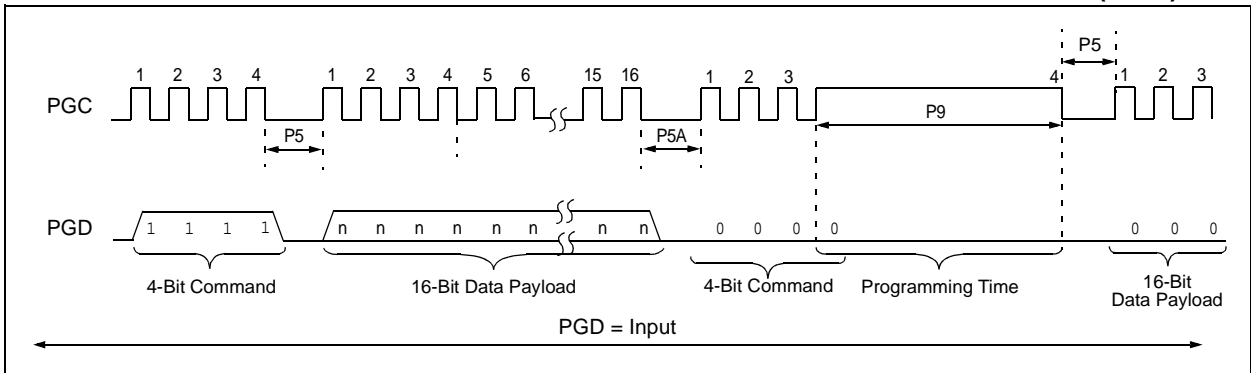

FIGURE 3-6: TABLE WRITE AND START PROGRAMMING INSTRUCTION TIMING (1111)



PIC18F2XJXX/4XJXX FAMILY

3.2.1 MODIFYING CODE MEMORY

The previous programming example assumed that the device had been Bulk Erased prior to programming. It may be the case, however, that the user wishes to modify only a section of an already programmed device.

As described in **Section 4.2 “Verify Code Memory and Configuration Word”**, the appropriate number of bytes required for the erase buffer must be read out of code memory and buffered. Modifications can be made on this buffer. Then, the block of code memory that was read out must be erased and rewritten with the modified data. The code sequence is shown in Table 3-4.

The WREN bit must be set if the WR bit in EECON1 is used to initiate a write sequence.

3.2.2 CONFIGURATION WORD PROGRAMMING

Since the Flash Configuration Words are stored in program memory, they are programmed as if they were program data. Refer to **Section 3.2 “Code Memory Programming”** and **Section 3.2.1 “Modifying Code Memory”** for methods and examples on programming or modifying program memory. See also **Section 5.0 “Configuration Word”** for additional information on the Configuration Words.

TABLE 3-4: MODIFYING CODE MEMORY

4-Bit Command	Data Payload	Core Instruction
Step 1: Set the Table Pointer for the block to be erased.		
0000	0E <Addr[21:16]>	MOVLW <Addr[21:16]>
0000	6E F8	MOVWF TBLPTRU
0000	0E <Addr[8:15]>	MOVLW <Addr[8:15]>
0000	6E F7	MOVWF TBLPTRH
0000	0E <Addr[7:0]>	MOVLW <Addr[7:0]>
0000	6E F6	MOVWF TBLPTRL
Step 2: Read and modify code memory (see Section 4.1 “Read Code Memory”).		
Step 3: Enable memory writes and set up an erase.		
0000	84 A6	BSF EECON1, WREN
0000	88 A6	BSF EECON1, FREE
Step 4: Initiate erase.		
0000	82 A6	BSF EECON1, WR
0000	00 00	NOP - hold PGC high for time P10.
Step 5: Load write buffer. The correct bytes will be selected based on the Table Pointer.		
0000	0E <Addr[21:16]>	MOVLW <Addr[21:16]>
0000	6E F8	MOVWF TBLPTRU
0000	0E <Addr[8:15]>	MOVLW <Addr[8:15]>
0000	6E F7	MOVWF TBLPTRH
0000	0E <Addr[7:0]>	MOVLW <Addr[7:0]>
0000	6E F6	MOVWF TBLPTRL
1101	<MSB><LSB>	Write 2 bytes and post-increment address by 2.
.	.	Repeat write operation 30 more times to fill the write buffer
.	.	
.	.	
1111	<MSB><LSB>	Write 2 bytes and start programming.
0000	00 00	NOP - hold PGC high for time P9.
Step 6: Repeat Step 5 for a total of 16 times (if rewriting the entire 1024 bytes of the erase page size).		
Step 7: To continue modifying data, repeat Steps 1 through 5, where the Address Pointer is incremented by 1024 bytes at each iteration of the loop.		
Step 8: Disable writes.		
0000	94 A6	BCF EECON1, WREN

3.3 Endurance and Retention

To maintain the endurance specification of the Flash program memory cells, each byte should never be programmed more than once between erase operations. Before attempting to modify the contents of a specific byte of Flash memory a second time, an erase operation (either a Bulk Erase or a Row Erase which includes that byte) should be performed.

PIC18F2XJXX/4XJXX FAMILY

4.0 READING THE DEVICE

4.1 Read Code Memory

Code memory is accessed one byte at a time via the 4-bit command, '1001' (table read, post-increment). The contents of memory pointed to by the Table Pointer (TBLPTRU:TBLPTRH:TBLPTRL) are serially output on PGD.

The 4-bit command is shifted in LSb first. The read is executed during the next eight clocks, then shifted out on PGD during the last eight clocks, LSb to MSb. A

delay of P6 must be introduced after the falling edge of the 8th PGC of the operand to allow PGD to transition from an input to an output. During this time, PGC must be held low (see Figure 4-1). This operation also increments the Table Pointer by one, pointing to the next byte in code memory for the next read.

This technique will work to read any memory in the 000000h to 3FFFFFFh address space, so it also applies to reading the Configuration registers.

TABLE 4-1: READ CODE MEMORY SEQUENCE

4-Bit Command	Data Payload	Core Instruction
Step 1: Set Table Pointer.		
0000	0E <Addr[21:16]>	MOVLW Addr[21:16]
0000	6E F8	MOVWF TBLPTRU
0000	0E <Addr[15:8]>	MOVLW <Addr[15:8]>
0000	6E F7	MOVWF TBLPTRH
0000	0E <Addr[7:0]>	MOVLW <Addr[7:0]>
0000	6E F6	MOVWF TBLPTRL
Step 2: Read memory and then shift out on PGD, LSb to MSb.		
1001	00 00	TBLRD *+

FIGURE 4-1: TABLE READ, POST-INCREMENT INSTRUCTION TIMING (1001)

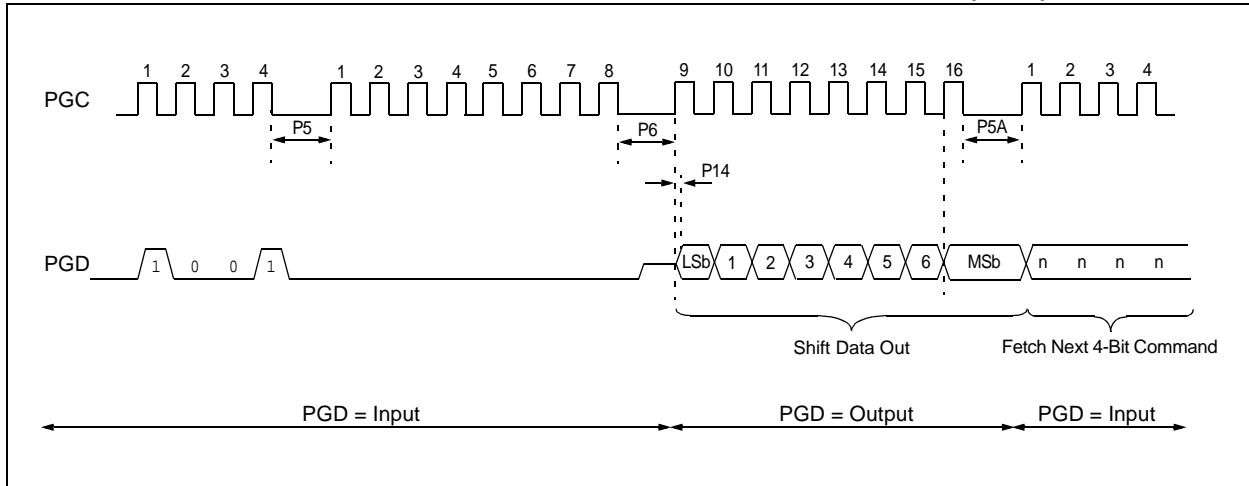

PIC18F2XJXX/4XJXX FAMILY

TABLE 5-3: PIC18F45J10 FAMILY DEVICES: BIT DESCRIPTIONS

Bit Name	Configuration Words	Description
DEBUG	CONFIG1L	Background Debugger Enable bit 1 = Background debugger disabled, RB6 and RB7 configured as general purpose I/O pins 0 = Background debugger enabled, RB6 and RB7 are dedicated to in-circuit debug
XINST	CONFIG1L	Extended Instruction Set Enable bit 1 = Instruction set extension and Indexed Addressing mode enabled 0 = Instruction set extension and Indexed Addressing mode disabled (Legacy mode)
STVREN	CONFIG1L	Stack Overflow/Underflow Reset Enable bit 1 = Reset on stack overflow/underflow enabled 0 = Reset on stack overflow/underflow disabled
WDTEN	CONFIG1L	Watchdog Timer Enable bit 1 = WDT enabled 0 = WDT disabled (control is placed on SWDTEN bit)
CP0	CONFIG1H	Code Protection bit 1 = Program memory is not code-protected 0 = Program memory is code-protected
IESO	CONFIG2L	Internal/External Oscillator Switchover bit 1 = Oscillator Switchover mode enabled 0 = Oscillator Switchover mode disabled
FCMEN	CONFIG2L	Fail-Safe Clock Monitor Enable bit 1 = Fail-Safe Clock Monitor enabled 0 = Fail-Safe Clock Monitor disabled
FOSC2	CONFIG2L	Default Oscillator Select bit 1 = Clock designated by FOSC<1:0> is enabled as system clock when OSCCON<1:0> = 00 0 = INTRC is enabled as system clock when OSCCON<1:0> = 00
FOSC<1:0>	CONFIG2L	Primary Oscillator Select bits 11 = EC oscillator, PLL enabled and under software control, CLKO function on OSC2 10 = EC oscillator, CLKO function on OSC2 01 = HS oscillator, PLL enabled and under software control 00 = HS oscillator
WDTPS<3:0>	CONFIG2H	Watchdog Timer Postscale Select bits 1111 = 1:32,768 1110 = 1:16,384 1101 = 1:8,192 1100 = 1:4,096 1011 = 1:2,048 1010 = 1:1,024 1001 = 1:512 1000 = 1:256 0111 = 1:128 0110 = 1:64 0101 = 1:32 0100 = 1:16 0011 = 1:8 0010 = 1:4 0001 = 1:2 0000 = 1:1
CCP2MX	CONFIG3H	CCP2 MUX bit 1 = CCP2 is multiplexed with RC1 0 = CCP2 is multiplexed with RB3

PIC18F2XJXX/4XJXX FAMILY

TABLE 5-5: PIC18F46J11 AND PIC18F46J50 FAMILY DEVICES: BIT DESCRIPTIONS (CONTINUED)

Bit Name	Configuration Words	Description
CP0 ⁽⁴⁾	CONFIG1H	Code Protection bit 1 = Program memory is not code-protected 0 = Program memory is code-protected
CPDIV<1:0> ⁽³⁾	CONFIG1H	CPU System Clock Selection bits 11 = No CPU system clock divide 10 = CPU system clock divided by 2 01 = CPU system clock divided by 3 00 = CPU system clock divided by 6
IESO	CONFIG2L ^(1,2)	Two-Speed Start-up (Internal/External Oscillator Switchover) Control bit 1 = Oscillator Switchover mode enabled 0 = Oscillator Switchover mode disabled
FCMEN	CONFIG2L ^(1,2)	Fail-Safe Clock Monitor Enable bit 1 = Fail-Safe Clock Monitor enabled 0 = Fail-Safe Clock Monitor disabled
LPT1OSC	CONFIG2L ^(1,2)	Low-Power Timer1 Oscillator Enable bit 1 = Timer1 oscillator configured for low-power operation 0 = Timer1 oscillator configured for higher-power operation
T1DIG	CONFIG2L ^(1,2)	Secondary Clock Source T1OSCEN Enforcement bit ⁽¹⁾ 1 = Secondary oscillator clock source may be selected (OSCCON <1:0> = 01) regardless of T1OSCEN state 0 = Secondary oscillator clock source may not be selected unless T1CON <3> = 1
FOSC<2:0>	CONFIG2L ^(1,2)	Oscillator Selection bits 111 =EC+PLL (S/W controlled by PLEN bit), CLKO on RA6 110 =EC oscillator (PLL always disabled) with CLKO on RA6 101 =HS+PLL (S/W controlled by PLEN bit) 100 =HS oscillator (PLL always disabled) 011 =INTOSCPLLO, internal oscillator with PLL (S/W controlled by PLEN bit), CLKO on RA6, port function on RA7 010 =INTOSCPLL, internal oscillator with PLL (S/W controlled by PLEN bit), port function on RA6 and RA7 001 =INTOSCO, internal oscillator, INTOSC or INTRC (PLL always disabled), CLKO on RA6, port function on RA7 000 =INTOSC, internal oscillator INTOSC or INTRC (PLL always disabled), port function on RA6 and RA7
WDTPS<3:0>	CONFIG2H ^(1,2)	Watchdog Timer Postscale Select bits 1111 = 1:32,768 1110 = 1:16,384 1101 = 1:8,192 1100 = 1:4,096 1011 = 1:2,048 1010 = 1:1,024 1001 = 1:512 1000 = 1:256 0111 = 1:128 0110 = 1:64 0101 = 1:32 0100 = 1:16 0011 = 1:8 0010 = 1:4 0001 = 1:2 0000 = 1:1

- Note 1:** The Configuration bits can only be programmed indirectly by programming the Flash Configuration Word.
Note 2: The Configuration bits are reset to '1' only on VDD Reset; it is reloaded with the programmed value at any device Reset.
Note 3: These bits are not implemented in PIC18F46J11 family devices.
Note 4: Once this bit is cleared, all the Configuration registers which reside in the last page are also protected. To disable code protection, perform an ICSP™ Bulk Erase operation.

PIC18F2XJXX/4XJXX FAMILY

TABLE 5-7: PIC18F47J13 AND PIC18F47J53 FAMILY DEVICES: BIT DESCRIPTIONS

Bit Name	Configuration Words	Description
DEBUG	CONFIG1L	Background Debugger Enable bit 1 = Background debugger disabled, RB6 and RB7 configured as general purpose I/O pins 0 = Background debugger enabled, RB6 and RB7 are dedicated to in-circuit debug
XINST	CONFIG1L	Enhanced Instruction Set Enable bit 1 = Instruction set extension and Indexed Addressing mode enabled 0 = Instruction set extension and Indexed Addressing mode disabled (Legacy mode)
STVREN	CONFIG1L	Stack Overflow/Underflow Reset Enable bit 1 = Reset on stack overflow/underflow enabled 0 = Reset on stack overflow/underflow disabled
CFGPLEN	CONFIG1L	Enable PLL on Start-up bit 1 = PLL enabled on start-up. Not recommended for low-voltage designs. 0 = PLL disabled on start-up. Firmware may later enable PLL through OSCTUNE<6>.
PLLDIV<2:0>	CONFIG1L	96 MHz PLL Input Divider bits Divider must be selected to provide a 4 MHz input into the 96 MHz PLL. 111 = No divide – oscillator used directly (4 MHz input) 110 = Oscillator divided by 2 (8 MHz input) 101 = Oscillator divided by 3 (12 MHz input) 100 = Oscillator divided by 4 (16 MHz input) 011 = Oscillator divided by 5 (20 MHz input) 010 = Oscillator divided by 6 (24 MHz input) 001 = Oscillator divided by 10 (40 MHz input) 000 = Oscillator divided by 12 (48 MHz input)
WDTEN	CONFIG1L	Watchdog Timer Enable bit 1 = WDT enabled 0 = WDT disabled (control is placed on the SWDTEN bit)
CP0 ⁽⁴⁾	CONFIG1H	Code Protection bit 1 = Program memory is not code-protected 0 = Program memory is code-protected
CPDIV<1:0> ⁽³⁾	CONFIG1H	CPU System Clock Selection bits 11 = No CPU system clock divide 10 = CPU system clock divided by 2 01 = CPU system clock divided by 3 00 = CPU system clock divided by 6
IESO	CONFIG2L ^(1,2)	Two-Speed Start-up (Internal/External Oscillator Switchover) Control bit 1 = Oscillator Switchover mode enabled 0 = Oscillator Switchover mode disabled
FCMEN	CONFIG2L ^(1,2)	Fail-Safe Clock Monitor Enable bit 1 = Fail-Safe Clock Monitor enabled 0 = Fail-Safe Clock Monitor disabled
CLKOEC	CONFIG2L	EC Mode Clock Output Enable bit 1 = CLKO output signal active on the RA6 pin (EC mode only) 0 = CLKO output disabled
SOSCSEL<1:0>	CONFIG2L	Secondary Oscillator Circuit Selection bits 11 = High-power SOSC circuit selected 10 = Digital Input mode (SCLKI) 01 = Low-power SOSC circuit selected 00 = Reserved

- Note 1:** The Configuration bits can only be programmed indirectly by programming the Flash Configuration Word.
Note 2: The Configuration bits are reset to '1' only on VDD Reset; it is reloaded with the programmed value at any device Reset.
Note 3: These bits are not implemented in PIC18F47J13 family devices.
Note 4: Once this bit is cleared, all the Configuration registers which reside in the last page are also protected. To disable code protection, perform an ICSP™ Bulk Erase operation.
Note 5: Not implemented on PIC18F47J53 family devices.

PIC18F2XJXX/4XJXX FAMILY

5.1 Device ID Word

The Device ID Word for the PIC18F2XJXX/4XJXX Family devices is located at 3FFFFEh:3FFFFFh. These read-only bits may be used by the programmer to identify what device type is being programmed and read out normally, even after code protection has been enabled. The process for reading the Device IDs is shown in Figure 5-1. A complete list of Device ID values for the PIC18F2XJXX/4XJXX Family is presented in Table 5-8.

FIGURE 5-1: READ DEVICE ID WORD FLOW

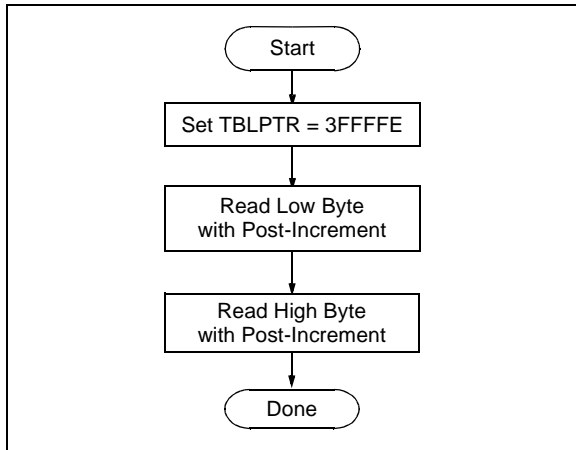

TABLE 5-8: DEVICE ID VALUE

Device	Device ID Value	
	DEVID2	DEVID1
PIC18F24J10	1Dh	000x xxxx
PIC18F25J10	1Ch	000x xxxx
PIC18F44J10	1Dh	001x xxxx
PIC18F45J10	1Ch	001x xxxx
PIC18LF24J10	1Dh	010x xxxx
PIC18LF25J10	1Ch	010x xxxx
PIC18LF44J10	1Dh	011x xxxx
PIC18LF45J10	1Ch	011x xxxx
PIC18F25J11	4Dh	101x xxxx
PIC18F24J11	4Dh	100x xxxx
PIC18F26J11	4Dh	110x xxxx
PIC18F45J11	4Eh	000x xxxx
PIC18F44J11	4Dh	111x xxxx
PIC18F46J11	4Eh	001x xxxx
PIC18F24J50	4Ch	000x xxxx
PIC18F25J50	4Ch	001x xxxx
PIC18F26J50	4Ch	010x xxxx
PIC18F44J50	4Ch	011x xxxx
PIC18F45J50	4Ch	100x xxxx

TABLE 5-8: DEVICE ID VALUE (CONTINUED)

Device	Device ID Value	
	DEVID2	DEVID1
PIC18F46J50	4Ch	101x xxxx
PIC18LF2450	4Ch	110x xxxx
PIC18LF25J50	4Ch	111x xxxx
PIC18LF26J50	4Dh	000x xxxx
PIC18LF44J50	4Dh	001x xxxx
PIC18LF45J50	4Dh	010x xxxx
PIC18LF46J50	4Dh	011x xxxx
PIC18LF24J11	4Eh	010x xxxx
PIC18LF25J11	4Eh	011x xxxx
PIC18LF26J11	4Eh	100x xxxx
PIC18LF44J11	4Eh	101x xxxx
PIC18LF45J11	4Eh	110x xxxx
PIC18LF46J11	4Eh	111x xxxx
PIC18F26J13	59h	001x xxxx
PIC18F27J13	59h	011x xxxx
PIC18F46J13	59h	101x xxxx
PIC18F47J13	59h	111x xxxx
PIC18LF26J13	5Bh	001x xxxx
PIC18LF27J13	5Bh	011x xxxx
PIC18LF46J13	5Bh	101x xxxx
PIC18LF47J13	5Bh	111x xxxx
PIC18F26J53	58h	001x xxxx
PIC18F27J53	58h	011x xxxx
PIC18F46J53	58h	101x xxxx
PIC18F47J53	58h	111x xxxx
PIC18LF26J53	5Ah	001x xxxx
PIC18LF27J53	5Ah	011x xxxx
PIC18LF46J53	5Ah	101x xxxx
PIC18LF47J53	5Ah	111x xxxx

5.2 Checksum Computation

The checksum is calculated by summing the contents of all code memory locations and the device Configuration Words, appropriately masked. The Least Significant 16 bits of this sum are the checksum.

The checksum calculation differs depending on whether or not code protection is enabled. Since the code memory locations read out differently depending on the code-protect setting, the table describes how to manipulate the actual code memory values to simulate the values that would be read from a protected device. When calculating a checksum by reading a device, the entire code memory can simply be read and summed. The Configuration Words can always be read.

PIC18F2XJXX/4XJXX FAMILY

Table 5-9 describes how to calculate the checksum for each device.

TABLE 5-9: CHECKSUM COMPUTATION

Device	Code Protection	Checksum
PIC18F24J10 PIC18F44J10	Off	SUM[000000:003FF7] + ([003FF8] & E1h) + ([003FF9] & 04h) + ([003FFA] & C7h) + ([003FFB] & 0Fh) + ([003FFD] & 01h)
	On	0000h
PIC18F24J11 PIC18F44J11	Off	SUM[000000:003FF7] + ([003FF8] & E1h) + ([003FF9] & FCh) + ([003FFA] & DFh) + ([003FFB] & FFh) + ([003FFC] & FFh) + ([003FFD] & F9h) + ([003FFE] & FFh) + ([003FFF] & F1h)
	On	0000h
PIC18F24J50 PIC18F44J50	Off	SUM[000000:003FF7] + ([003FF8] & EFh) + ([003FF9] & FFh) + ([003FFA] & DFh) + ([003FFB] & FFh) + ([003FFC] & FFh) + ([003FFD] & F9h) + ([003FFE] & FFh) + ([003FFF] & F1h)
	On	0000h
PIC18F25J10 PIC18F45J10	Off	SUM[000000:007FF7] + ([007FF8] & E1h) + ([007FF9] & 04h) + ([007FFA] & C7h) + ([007FFB] & 0Fh) + ([007FFD] & 01h)
	On	0000h
PIC18F25J11 PIC18F45J11	Off	SUM[000000:007FF7] + ([007FF8] & E1h) + ([007FF9] & FCh) + ([007FFA] & DFh) + ([007FFB] & FFh) + ([007FFC] & FFh) + ([007FFD] & F9h) + ([007FFE] & FFh) + ([007FFF] & F1h)
	On	0000h
PIC18F25J50 PIC18F45J50	Off	SUM[000000:007FF7] + ([007FF8] & EFh) + ([007FF9] & FFh) + ([007FFA] & DFh) + ([007FFB] & FFh) + ([007FFC] & FFh) + ([007FFD] & F9h) + ([007FFE] & FFh) + ([007FFF] & F1h)
	On	0000h
PIC18F26J11 PIC18F46J11	Off	SUM[000000:00FFF7] + ([00FFF8] & E1h) + ([00FFF9] & FCh) + ([00FFFA] & DFh) + ([00FFFB] & FFh) + ([00FFFC] & FFh) + ([00FFFD] & F9h) + ([00FFFE] & FFh) + ([00FFFF] & F1h)
	On	0000h
PIC18F26J50 PIC18F46J50	Off	SUM[000000:00FFF7] + ([00FFF8] & EFh) + ([00FFF9] & FFh) + ([00FFFA] & DFh) + ([00FFFB] & FFh) + ([00FFFC] & FFh) + ([00FFFD] & F9h) + ([00FFFE] & FFh) + ([00FFFF] & F1h)
	On	0000h
PIC18F26J13 PIC18F46J13	Off	SUM[000000:00FFF7] + ([00FFF8] & FFh) + ([00FFF9] & FCh) + ([00FFFA] & FFh) + ([00FFFB] & FFh) + ([00FFFC] & FFh) + ([00FFFD] & FFh) + ([00FFFE] & BFh) + ([00FFFF] & F3h)
	On	0000h
PIC18F26J53 PIC18F46J53	Off	SUM[000000:00FFF7] + ([00FFF8] & FFh) + ([00FFF9] & FFh) + ([00FFFA] & FFh) + ([00FFFB] & FFh) + ([00FFFC] & FFh) + ([00FFFD] & FBh) + ([00FFFE] & BFh) + ([00FFFF] & FBh)
	On	0000h
PIC18F27J13 PIC18F47J13	Off	SUM[000000:01FFF7] + ([01FFF8] & FFh) + ([01FFF9] & FCh) + ([01FFFA] & FFh) + ([01FFFB] & FFh) + ([01FFFC] & FFh) + ([01FFFD] & FFh) + ([01FFFE] & FFh) + ([01FFFF] & F3h)
	On	0000h
PIC18F27J53 PIC18F47J53	Off	SUM[000000:01FFF7] + ([01FFF8] & FFh) + ([01FFF9] & FFh) + ([01FFFA] & FFh) + ([01FFFB] & FFh) + ([01FFFC] & FFh) + ([01FFFD] & FBh) + ([01FFFE] & FFh) + ([01FFFF] & FBh)
	On	0000h

Legend: [a] = Value at address a; SUM[a:b] = Sum of locations a to b inclusive; + = Addition; & = Bitwise AND. All addresses are hexadecimal.

PIC18F2XJXX/4XJXX FAMILY

6.0 AC/DC CHARACTERISTICS TIMING REQUIREMENTS FOR PROGRAM/VERIFY TEST MODE

Standard Operating Conditions								
Operating Temperature: 25°C is recommended								
Param No.	Symbol	Characteristic	Min.	Max.	Units	Conditions		
	VDDCORE	External Supply Voltage for Microcontroller Core During Programming Operations (PIC18LF devices)	2.25	2.75	V	(Note 1)		
D111	VDD	Supply Voltage During Programming	PIC18LFXXJXX	VDDCORE	3.60	V	Normal programming (Note 2)	
			PIC18FXXJ10		2.70	3.60		V
			PIC18FXXJ50		2.35	3.60	V	
			PIC18FXXJ11					
			PIC18FXXJ53 PIC18FXXJ13					
D112	I _{PP}	Programming Current on $\overline{\text{MCLR}}$	—	5	μA			
D113	I _{DDP}	Supply Current During Programming	—	10	mA			
D031	V _{IL}	Input Low Voltage	V _{SS}	0.2 V _{DD}	V			
D041	V _{IH}	Input High Voltage	0.8 V _{DD}	V _{DD}	V			
D080	V _{OL}	Output Low Voltage	—	0.4	V	I _{OL} = 3.4 mA @ 3.3V		
D090	V _{OH}	Output High Voltage	2.4	—	V	I _{OH} = -2.0 mA @ 3.3V		
D012	C _{IO}	Capacitive Loading on I/O pin (PGD)	—	50	pF	To meet AC specifications		
	C _F	Filter Capacitor Value on V _{CAP}	PIC18LFXXJXX	0.1	—	μF	(Note 1)	
			PIC18FXXJ10	4.7	18	μF		
			PIC18FXXJ13	5.4	18	μF		
			PIC18FXXJ11					
			PIC18FXXJ5X					

Note 1: External power must be supplied to the VDDCORE/V_{CAP} pin if the on-chip voltage regulator is disabled. See Section 2.1.1 “PIC18F2XJXX/4XJXX/ LF2XJXX/LF4XJXX Devices and the On-Chip Voltage Regulator” for more information.

2: VDD must also be supplied to the AVDD pins during programming. AVDD and AVSS should always be within ±0.3V of VDD and VSS, respectively.

PIC18F2XJXX/4XJXX FAMILY

6.0 AC/DC CHARACTERISTICS TIMING REQUIREMENTS FOR PROGRAM/VERIFY TEST MODE (CONTINUED)

Standard Operating Conditions						
Operating Temperature: 25°C is recommended						
Param No.	Symbol	Characteristic	Min.	Max.	Units	Conditions
P1	TR	MCLR Rise Time to Enter Program/Verify mode	—	1.0	μs	
P2	TPGC	Serial Clock (PGC) Period	100	—	ns	
P2A	TPGCL	Serial Clock (PGC) Low Time	50	—	ns	
P2B	TPGCH	Serial Clock (PGC) High Time	50	—	ns	
P3	TSET1	Input Data Setup Time to Serial Clock ↓	20	—	ns	
P4	THLD1	Input Data Hold Time from PGC ↓	20	—	ns	
P5	TDLY1	Delay Between 4-Bit Command and Command Operand	50	—	ns	
P5A	TDLY1A	Delay Between 4-Bit Command Operand and Next 4-Bit Command	50	—	ns	
P6	TDLY2	Delay Between Last PGC ↓ of Command Byte to First PGC ↑ of Read of Data Word	20	—	ns	
P9	TDLY5	Delay to allow Block Programming to occur	3.4	—	ms	PIC18F2XJ10/PIC18F4XJ10
			1.2	—	ms	PIC18F2XJ11/PIC18F4XJ11/ PIC18F2XJ13/PIC18F4XJ13/ PIC18F2XJ5X/PIC18F4XJ5X
P10	TDLY6	Delay to allow Row Erase to occur	49	—	ms	PIC18F2XJ10/PIC18F4XJ10/ PIC18F2XJ13/PIC18F4XJ13/ PIC18F2XJ53/PIC18F4XJ53
			54	—	ms	PIC18F2XJ11/PIC18F4XJ11/ PIC18F2XJ50/PIC18F4XJ50
P11	TDLY7	Delay to allow Bulk Erase to occur	475	—	ms	PIC18F2XJ10/PIC18F4XJ10/ PIC18F2XJ13/PIC18F4XJ13/ PIC18F2XJ53/PIC18F4XJ53
			524	—	ms	PIC18F2XJ11/PIC18F4XJ11/ PIC18F2XJ50/PIC18F4XJ50
P12	THLD2	Input Data Hold Time from MCLR ↑	400	—	μs	
P13	TSET2	VDD ↑ Setup Time to MCLR ↑	100	—	ns	
P14	TVALID	Data Out Valid from PGC ↑	25	—	ns	
P16	TDLY8	Delay between Last PGC ↓ and MCLR ↓	20	—	ns	
P17	THLD3	MCLR ↓ to VDD ↓	3	—	μs	
P19	TKEY1	Delay from First MCLR ↓ to First PGC ↑ for Key Sequence on PGD	4	—	ms	
P20	TKEY2	Delay from Last PGC ↓ for Key Sequence on PGD to Second MCLR ↑	50	—	ns	

- Note 1:** External power must be supplied to the VDDCORE/VCAP pin if the on-chip voltage regulator is disabled. See **Section 2.1.1 “PIC18F2XJXX/4XJXX/ LF2XJXX/LF4XJXX Devices and the On-Chip Voltage Regulator”** for more information.
- 2:** VDD must also be supplied to the AVDD pins during programming. AVDD and AVSS should always be within ±0.3V of VDD and VSS, respectively.

Note the following details of the code protection feature on Microchip devices:

- Microchip products meet the specification contained in their particular Microchip Data Sheet.
- Microchip believes that its family of products is one of the most secure families of its kind on the market today, when used in the intended manner and under normal conditions.
- There are dishonest and possibly illegal methods used to breach the code protection feature. All of these methods, to our knowledge, require using the Microchip products in a manner outside the operating specifications contained in Microchip's Data Sheets. Most likely, the person doing so is engaged in theft of intellectual property.
- Microchip is willing to work with the customer who is concerned about the integrity of their code.
- Neither Microchip nor any other semiconductor manufacturer can guarantee the security of their code. Code protection does not mean that we are guaranteeing the product as “unbreakable.”

Code protection is constantly evolving. We at Microchip are committed to continuously improving the code protection features of our products. Attempts to break Microchip's code protection feature may be a violation of the Digital Millennium Copyright Act. If such acts allow unauthorized access to your software or other copyrighted work, you may have a right to sue for relief under that Act.

Information contained in this publication regarding device applications and the like is provided only for your convenience and may be superseded by updates. It is your responsibility to ensure that your application meets with your specifications. MICROCHIP MAKES NO REPRESENTATIONS OR WARRANTIES OF ANY KIND WHETHER EXPRESS OR IMPLIED, WRITTEN OR ORAL, STATUTORY OR OTHERWISE, RELATED TO THE INFORMATION, INCLUDING BUT NOT LIMITED TO ITS CONDITION, QUALITY, PERFORMANCE, MERCHANTABILITY OR FITNESS FOR PURPOSE. Microchip disclaims all liability arising from this information and its use. Use of Microchip devices in life support and/or safety applications is entirely at the buyer's risk, and the buyer agrees to defend, indemnify and hold harmless Microchip from any and all damages, claims, suits, or expenses resulting from such use. No licenses are conveyed, implicitly or otherwise, under any Microchip intellectual property rights unless otherwise stated.

Trademarks

The Microchip name and logo, the Microchip logo, dsPIC, FlashFlex, flexPWR, JukeBlox, KEELOQ, KEELOQ logo, Klear, LANCheck, MediaLB, MOST, MOST logo, MPLAB, OptoLyzer, PIC, PICSTART, PIC³² logo, RightTouch, SpyNIC, SST, SST Logo, SuperFlash and UNI/O are registered trademarks of Microchip Technology Incorporated in the U.S.A. and other countries.

The Embedded Control Solutions Company and mTouch are registered trademarks of Microchip Technology Incorporated in the U.S.A.

Analog-for-the-Digital Age, BodyCom, chipKIT, chipKIT logo, CodeGuard, dsPICDEM, dsPICDEM.net, ECAN, In-Circuit Serial Programming, ICSP, Inter-Chip Connectivity, KlearNet, KlearNet logo, MiWi, motorBench, MPASM, MPF, MPLAB Certified logo, MPLIB, MPLINK, MultiTRAK, NetDetach, Omniscient Code Generation, PICDEM, PICDEM.net, PICKIT, PICtail, RightTouch logo, REAL ICE, SQI, Serial Quad I/O, Total Endurance, TSHARC, USBCheck, VariSense, ViewSpan, WiperLock, Wireless DNA, and ZENA are trademarks of Microchip Technology Incorporated in the U.S.A. and other countries.

SQTP is a service mark of Microchip Technology Incorporated in the U.S.A.

Silicon Storage Technology is a registered trademark of Microchip Technology Inc. in other countries.

GestIC is a registered trademark of Microchip Technology Germany II GmbH & Co. KG, a subsidiary of Microchip Technology Inc., in other countries.

All other trademarks mentioned herein are property of their respective companies.

© 2008-2015, Microchip Technology Incorporated, Printed in the U.S.A., All Rights Reserved.

ISBN: 978-1-63277-874-1

QUALITY MANAGEMENT SYSTEM
CERTIFIED BY DNV
== ISO/TS 16949 ==

Microchip received ISO/TS-16949:2009 certification for its worldwide headquarters, design and wafer fabrication facilities in Chandler and Tempe, Arizona; Gresham, Oregon and design centers in California and India. The Company's quality system processes and procedures are for its PIC® MCUs and dsPIC® DSCs, KEELOQ® code hopping devices, Serial EEPROMs, microperipherals, nonvolatile memory and analog products. In addition, Microchip's quality system for the design and manufacture of development systems is ISO 9001:2000 certified.

Worldwide Sales and Service

AMERICAS

Corporate Office

2355 West Chandler Blvd.
Chandler, AZ 85224-6199
Tel: 480-792-7200
Fax: 480-792-7277
Technical Support:
[http://www.microchip.com/
support](http://www.microchip.com/support)
Web Address:
www.microchip.com

Atlanta

Duluth, GA
Tel: 678-957-9614
Fax: 678-957-1455

Austin, TX

Tel: 512-257-3370

Boston

Westborough, MA
Tel: 774-760-0087
Fax: 774-760-0088

Chicago

Itasca, IL
Tel: 630-285-0071
Fax: 630-285-0075

Cleveland

Independence, OH
Tel: 216-447-0464
Fax: 216-447-0643

Dallas

Addison, TX
Tel: 972-818-7423
Fax: 972-818-2924

Detroit

Novi, MI
Tel: 248-848-4000

Houston, TX

Tel: 281-894-5983

Indianapolis

Noblesville, IN
Tel: 317-773-8323
Fax: 317-773-5453

Los Angeles

Mission Viejo, CA
Tel: 949-462-9523
Fax: 949-462-9608

New York, NY

Tel: 631-435-6000

San Jose, CA

Tel: 408-735-9110

Canada - Toronto

Tel: 905-673-0699
Fax: 905-673-6509

ASIA/PACIFIC

Asia Pacific Office

Suites 3707-14, 37th Floor
Tower 6, The Gateway
Harbour City, Kowloon

Hong Kong

Tel: 852-2943-5100
Fax: 852-2401-3431

Australia - Sydney

Tel: 61-2-9868-6733
Fax: 61-2-9868-6755

China - Beijing

Tel: 86-10-8569-7000
Fax: 86-10-8528-2104

China - Chengdu

Tel: 86-28-8665-5511
Fax: 86-28-8665-7889

China - Chongqing

Tel: 86-23-8980-9588
Fax: 86-23-8980-9500

China - Dongguan

Tel: 86-769-8702-9880

China - Hangzhou

Tel: 86-571-8792-8115
Fax: 86-571-8792-8116

China - Hong Kong SAR

Tel: 852-2943-5100
Fax: 852-2401-3431

China - Nanjing

Tel: 86-25-8473-2460
Fax: 86-25-8473-2470

China - Qingdao

Tel: 86-532-8502-7355
Fax: 86-532-8502-7205

China - Shanghai

Tel: 86-21-5407-5533
Fax: 86-21-5407-5066

China - Shenyang

Tel: 86-24-2334-2829
Fax: 86-24-2334-2393

China - Shenzhen

Tel: 86-755-8864-2200
Fax: 86-755-8203-1760

China - Wuhan

Tel: 86-27-5980-5300
Fax: 86-27-5980-5118

China - Xian

Tel: 86-29-8833-7252
Fax: 86-29-8833-7256

ASIA/PACIFIC

China - Xiamen

Tel: 86-592-2388138
Fax: 86-592-2388130

China - Zhuhai

Tel: 86-756-3210040
Fax: 86-756-3210049

India - Bangalore

Tel: 91-80-3090-4444
Fax: 91-80-3090-4123

India - New Delhi

Tel: 91-11-4160-8631
Fax: 91-11-4160-8632

India - Pune

Tel: 91-20-3019-1500

Japan - Osaka

Tel: 81-6-6152-7160
Fax: 81-6-6152-9310

Japan - Tokyo

Tel: 81-3-6880-3770
Fax: 81-3-6880-3771

Korea - Daegu

Tel: 82-53-744-4301
Fax: 82-53-744-4302

Korea - Seoul

Tel: 82-2-554-7200
Fax: 82-2-558-5932 or
82-2-558-5934

Malaysia - Kuala Lumpur

Tel: 60-3-6201-9857
Fax: 60-3-6201-9859

Malaysia - Penang

Tel: 60-4-227-8870
Fax: 60-4-227-4068

Philippines - Manila

Tel: 63-2-634-9065
Fax: 63-2-634-9069

Singapore

Tel: 65-6334-8870
Fax: 65-6334-8850

Taiwan - Hsin Chu

Tel: 886-3-5778-366
Fax: 886-3-5770-955

Taiwan - Kaohsiung

Tel: 886-7-213-7828

Taiwan - Taipei

Tel: 886-2-2508-8600
Fax: 886-2-2508-0102

Thailand - Bangkok

Tel: 66-2-694-1351
Fax: 66-2-694-1350

EUROPE

Austria - Wels

Tel: 43-7242-2244-39
Fax: 43-7242-2244-393

Denmark - Copenhagen

Tel: 45-4450-2828
Fax: 45-4485-2829

France - Paris

Tel: 33-1-69-53-63-20
Fax: 33-1-69-30-90-79

Germany - Dusseldorf

Tel: 49-2129-3766400

Germany - Karlsruhe

Tel: 49-721-625370

Germany - Munich

Tel: 49-89-627-144-0
Fax: 49-89-627-144-44

Italy - Milan

Tel: 39-0331-742611
Fax: 39-0331-466781

Italy - Venice

Tel: 39-049-7625286

Netherlands - Drunen

Tel: 31-416-690399
Fax: 31-416-690340

Poland - Warsaw

Tel: 48-22-3325737

Spain - Madrid

Tel: 34-91-708-08-90
Fax: 34-91-708-08-91

Sweden - Stockholm

Tel: 46-8-5090-4654

UK - Wokingham

Tel: 44-118-921-5800
Fax: 44-118-921-5820

07/14/15