

Welcome to [E-XFL.COM](https://www.e-xfl.com)

What is "[Embedded - Microcontrollers](#)"?

"[Embedded - Microcontrollers](#)" refer to small, integrated circuits designed to perform specific tasks within larger systems. These microcontrollers are essentially compact computers on a single chip, containing a processor core, memory, and programmable input/output peripherals. They are called "embedded" because they are embedded within electronic devices to control various functions, rather than serving as standalone computers. Microcontrollers are crucial in modern electronics, providing the intelligence and control needed for a wide range of applications.

Applications of "[Embedded - Microcontrollers](#)"

Details	
Product Status	Active
Core Processor	PIC
Core Size	8-Bit
Speed	48MHz
Connectivity	I ² C, SPI, UART/USART, USB
Peripherals	Brown-out Detect/Reset, DMA, POR, PWM, WDT
Number of I/O	34
Program Memory Size	16KB (8K x 16)
Program Memory Type	FLASH
EEPROM Size	-
RAM Size	3.8K x 8
Voltage - Supply (Vcc/Vdd)	2V ~ 3.6V
Data Converters	A/D 13x10b
Oscillator Type	Internal
Operating Temperature	-40°C ~ 85°C (TA)
Mounting Type	Surface Mount
Package / Case	44-VQFN Exposed Pad
Supplier Device Package	44-QFN (8x8)
Purchase URL	https://www.e-xfl.com/product-detail/microchip-technology/pic18lf44j50-i-ml

PIC18F2XJXX/4XJXX FAMILY

FIGURE 2-1: PIC18F2XJXX/4XJXX FAMILY PIN DIAGRAMS

28-Pin SPDIP, SOIC, SSOP

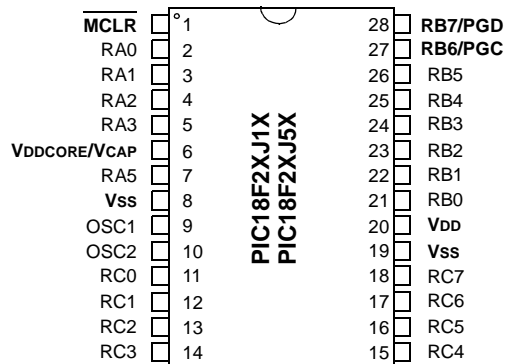

28-Pin QFN

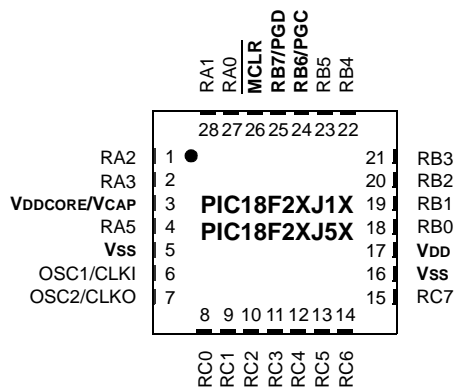

PIC18F2XJXX/4XJXX FAMILY

FIGURE 2-2: PIC18F2XJXX/4XJXX FAMILY PIN DIAGRAMS (CONTINUED)

40-Pin PDIP

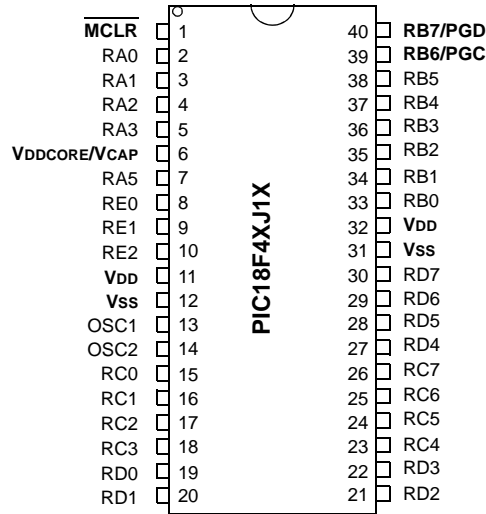

44-Pin QFN

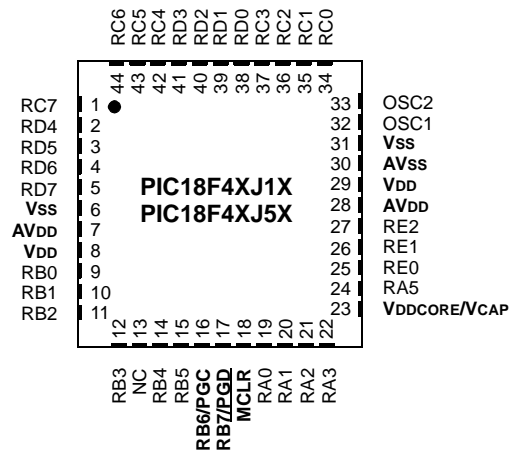

44-Pin TQFP

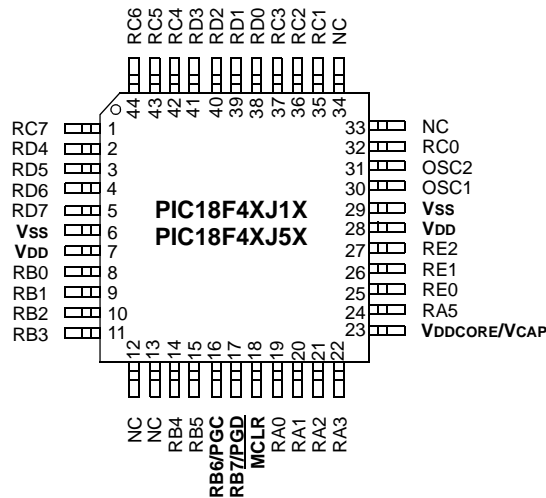

PIC18F2XJXX/4XJXX FAMILY

2.1.1 PIC18F2XJXX/4XJXX/ LF2XJXX/LF4XJXX DEVICES AND THE ON-CHIP VOLTAGE REGULATOR

PIC18FXXJXX devices have an internal core voltage regulator. On these devices (“PIC18F” in the part number), the regulator is always enabled. The regulator input is taken from the VDD pins of the microcontroller. The output of the regulator is supplied to the VDDCORE/VCAP pin. On these devices, this pin simultaneously serves as both regulator output and microcontroller core power input pin. For these devices, the VDDCORE/VCAP pin should be tied only to a capacitor.

PIC18LFXXJXX devices do not have an internal core voltage regulator. On the low-voltage devices (LF), power must be externally supplied to both VDD and VDDCORE/VCAP.

Whether or not the regulator is used, it is always good design practice to have sufficient capacitance on all supply pins. Examples are shown in Figure 2-3.

The specifications for core voltage and capacitance are listed in **Section 6.0 “AC/DC Characteristics Timing Requirements for Program/Verify Test Mode”**.

FIGURE 2-3: CONNECTIONS FOR THE ON-CHIP REGULATOR

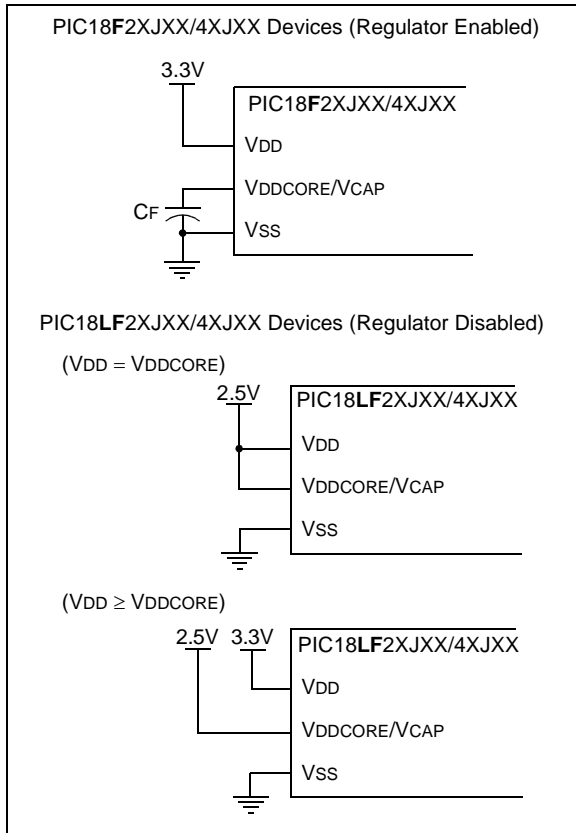

2.2 Memory Maps

The PIC18F2XJXX/4XJXX Family of devices offers program memory sizes of 16, 32, 64, and 128 Kbytes. The memory sizes for different members of the family are shown in Table 2-2. The overall memory maps for all the devices are shown in Figure 2-4.

TABLE 2-2: PROGRAM MEMORY SIZES FOR PIC18F2XJXX/4XJXX FAMILY DEVICES

Device*	Program Memory (Kbytes)	Location of Flash Configuration Words
PIC18F24J10	16	3FF8h:3FFFh
PIC18F44J10		
PIC18F24J11		
PIC18F44J11		
PIC18F24J50		
PIC18F44J50	32	7FF8h:7FFFh
PIC18F25J10		
PIC18F45J10		
PIC18F25J11		
PIC18F45J11		
PIC18F25J50	64	FFF8h:FFFFh
PIC18F45J50		
PIC18F26J11		
PIC18F46J11		
PIC18F26J13		
PIC18F46J13	128	1FFF8h:1FFFFh
PIC18F26J50		
PIC18F46J50		
PIC18F26J53		
PIC18F46J53		
PIC18F27J13	128	1FFF8h:1FFFFh
PIC18F47J13		
PIC18F27J53		
PIC18F47J53		

* Includes PIC18F and PIC18LF devices.

For purposes of code protection, the program memory for every device is treated as a single block. Therefore, enabling code protection, thus protecting the entire code memory and not individual segments.

PIC18F2XJXX/4XJXX FAMILY

FIGURE 2-4: MEMORY MAPS FOR PIC18F2XJXX/4XJXX FAMILY DEVICES⁽¹⁾

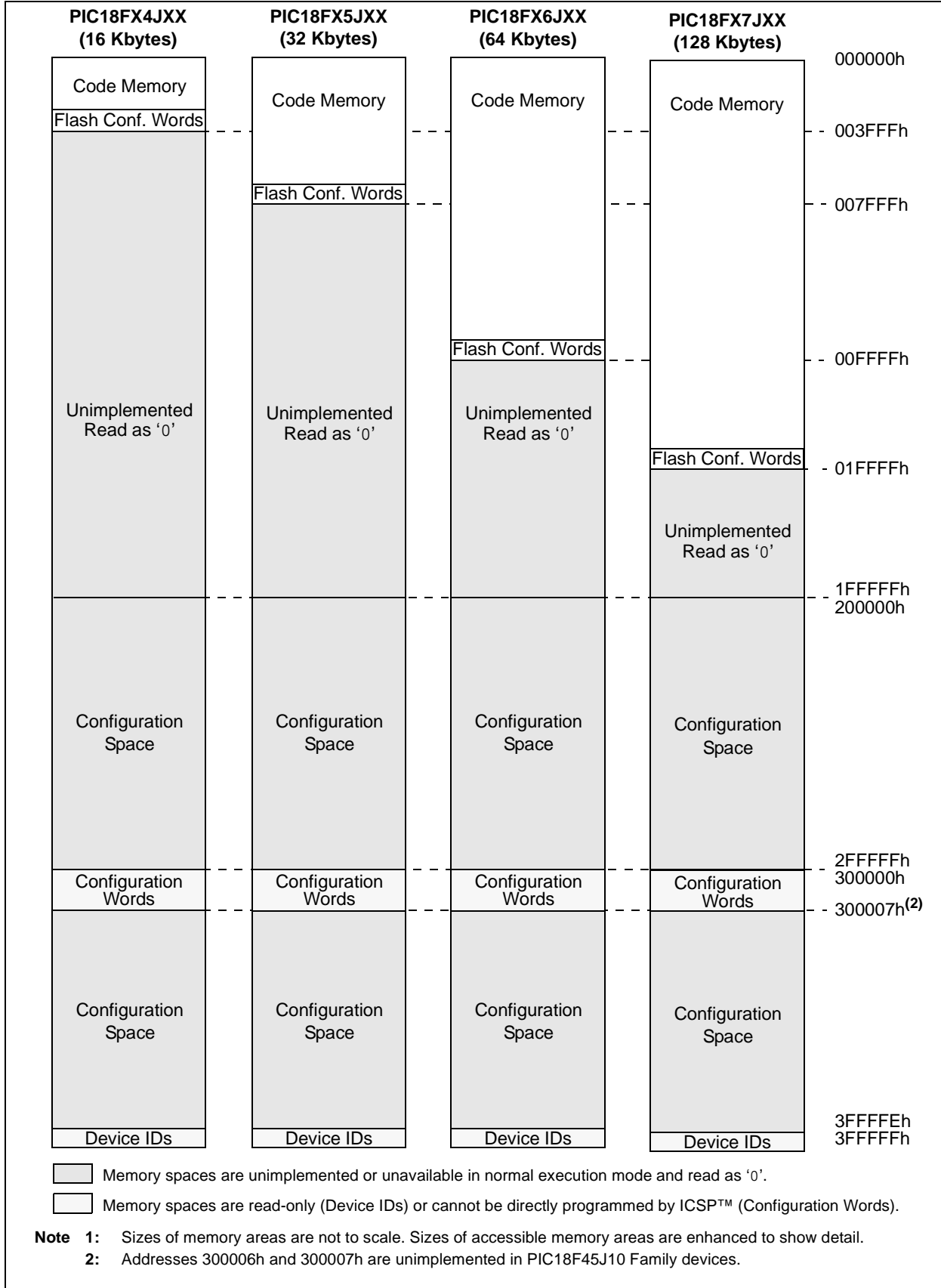

PIC18F2XJXX/4XJXX FAMILY

2.3 Overview of the Programming Process

Figure 2-5 shows the high-level overview of the programming process in which a Bulk Erase is performed first, then the code memory is programmed. Since only nonvolatile Configuration Words are within the code memory space, the Configuration Words are also programmed as code. Code memory (including the Configuration Words) is then verified to ensure that programming was successful.

FIGURE 2-5: HIGH-LEVEL PROGRAMMING FLOW

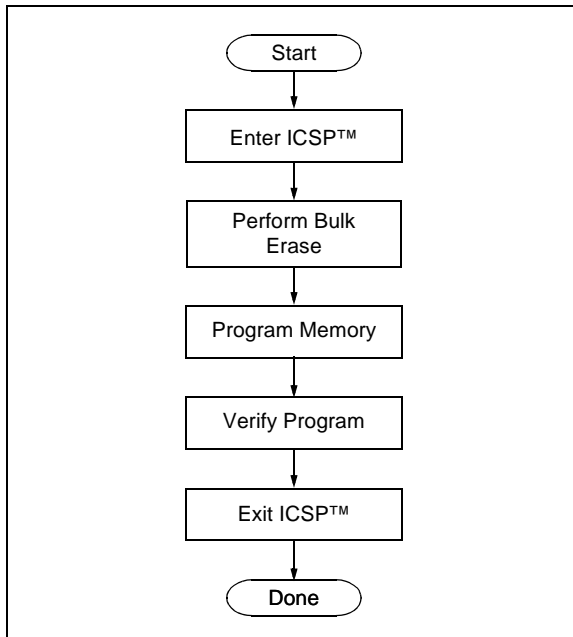

2.4 Entering and Exiting ICSP™ Program/Verify Mode

Entry into ICSP modes for PIC18F2XJXX/4XJXX Family devices is somewhat different than previous PIC18 devices. As shown in Figure 2-6, entering ICSP Program/Verify mode requires three steps:

1. Voltage is briefly applied to the $\overline{\text{MCLR}}$ pin.
2. A 32-bit key sequence is presented on PGD.
3. Voltage is reapplied to $\overline{\text{MCLR}}$ and held.

The programming voltage applied to $\overline{\text{MCLR}}$ is V_{IH} , or essentially, V_{DD} . There is no minimum time requirement for holding at V_{IH} . After V_{IH} is removed, an interval of at least P19 must elapse before presenting the key sequence on PGD.

The key sequence is a specific 32-bit pattern, '0100 1101 0100 0011 0100 1000 0101 0000', which is more easily remembered as 4D434850h in hexadecimal. The device will enter Program/Verify mode only if the sequence is valid. The Most Significant bit of the Most Significant nibble must be shifted in first.

Once the key sequence is complete, V_{IH} must be applied to $\overline{\text{MCLR}}$ and held at that level for as long as Program/Verify mode is to be maintained. An interval of at least time, P20 and P12, must elapse before presenting data on PGD. Signals appearing on PGD before P12 has elapsed may not be interpreted as valid.

On successful entry, the program memory can be accessed and programmed in serial fashion. While in the Program/Verify mode, all unused I/Os are placed in the high-impedance state.

Exiting Program/Verify mode is done by removing V_{IH} from $\overline{\text{MCLR}}$, as shown in Figure 2-7. The only requirement for exit is that an interval, P16, should elapse between the last clock and program signals on PGC and PGD before removing V_{IH} .

When V_{IH} is reapplied to $\overline{\text{MCLR}}$, the device will enter the ordinary operational mode and begin executing the application instructions.

FIGURE 2-6: ENTERING PROGRAM/VERIFY MODE

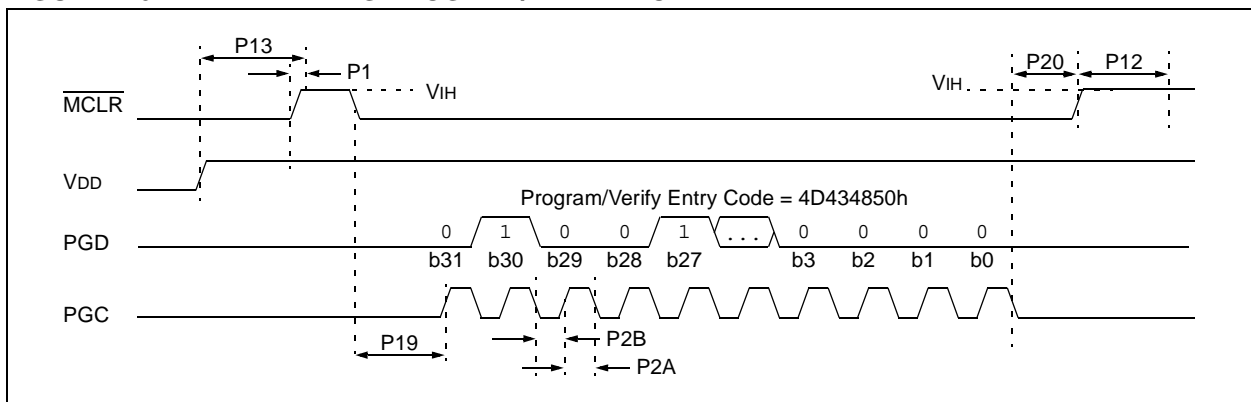

PIC18F2XJXX/4XJXX FAMILY

FIGURE 2-7: EXITING PROGRAM/VERIFY MODE

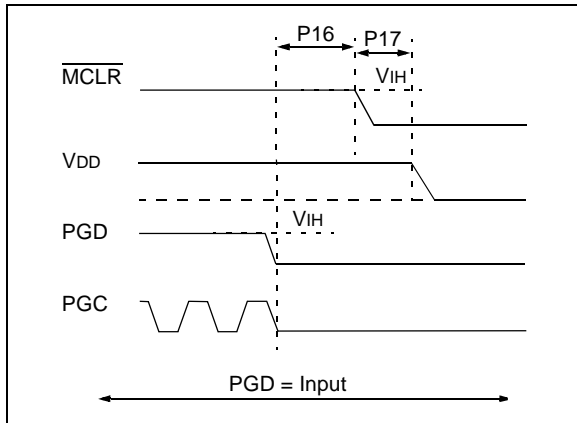

2.5 Serial Program/Verify Operation

The PGC pin is used as a clock input pin and the PGD pin is used for entering command bits and data input/output during serial operation. Commands and data are transmitted on the rising edge of PGC, latched on the falling edge of PGC, and are Least Significant bit (LSb) first.

2.5.1 FOUR-BIT COMMANDS

All instructions are 20 bits, consisting of a leading 4-bit command followed by a 16-bit operand, which depends on the type of command being executed. To input a command, PGC is cycled four times. The commands needed for programming and verification are shown in Table 2-3.

Depending on the 4-bit command, the 16-bit operand represents 16 bits of input data or eight bits of input data and eight bits of output data.

Throughout this specification, commands and data are presented as illustrated in Table 2-4. The 4-bit command is shown Most Significant bit (MSb) first. The command operand or “Data Payload” is shown <MSB><LSB>. Figure 2-8 demonstrates how to serially present a 20-bit command/operand to the device.

2.5.2 CORE INSTRUCTION

The core instruction passes a 16-bit instruction to the CPU core for execution. This is needed to set up registers as appropriate for use with other commands.

TABLE 2-3: COMMANDS FOR PROGRAMMING

Description	4-Bit Command
Core Instruction (Shift in 16-bit instruction)	0000
Shift out TABLAT register	0010
Table Read	1000
Table Read, Post-Increment	1001
Table Read, Post-Decrement	1010
Table Read, Pre-Increment	1011
Table Write	1100
Table Write, Post-Increment by 2	1101
Table Write, Start Programming, Post-Increment by 2	1110
Table Write, Start Programming	1111

TABLE 2-4: SAMPLE COMMAND SEQUENCE

4-Bit Command	Data Payload	Core Instruction
1101	3C 40	Table Write, post-increment by 2

FIGURE 2-8: TABLE WRITE, POST-INCREMENT TIMING (1101)

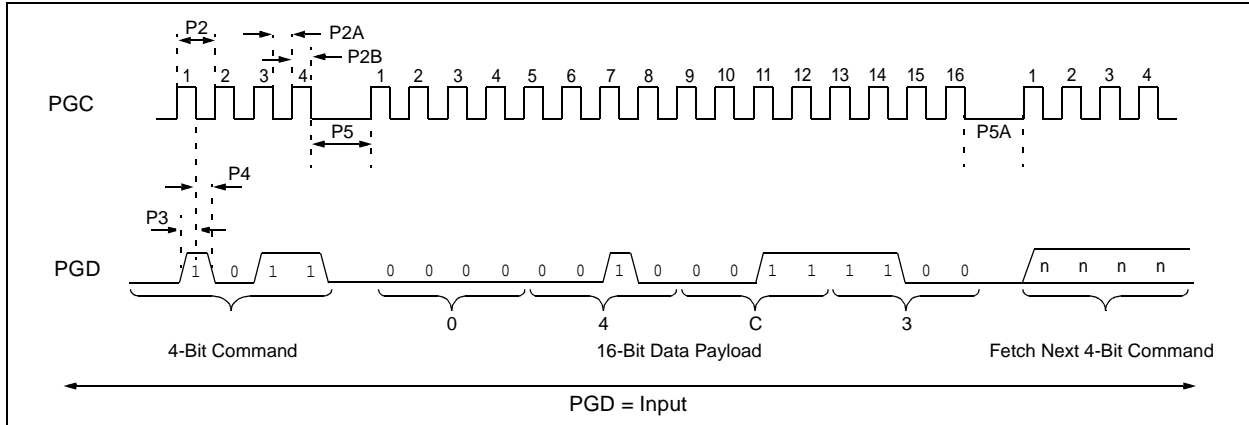

PIC18F2XJXX/4XJXX FAMILY

3.1.2 ICSP™ ROW ERASE

It is possible to erase one row (1024 bytes of data), provided the block is not code-protected or erase/write-protected. Rows are located at static boundaries beginning at program memory address 000000h, extending to the internal program memory limit. Refer to **Section 2.2 “Memory Maps”**).

The Row Erase duration is internally timed. After the WR bit in EECON1 is set, a NOP instruction is issued, where the 4th PGC is held high for the duration of the Row Erase time, P10.

The code sequence to Row Erase a PIC18F2XJXX/4XJXX Family device is shown in Table 3-2. The flowchart shown in Figure 3-4 depicts the logic necessary to completely erase a PIC18F2XJXX/4XJXX

Family device. The timing diagram that details the Row Erase command and parameter P10 is shown in Figure 3-3.

- Note 1:** If the last row of program memory is erased, bit 3 of CONFIG1H must also be programmed as '0'.
- 2:** The TBLPTR register can point at any byte within the row intended for erase.
- 3:** If code protection has been enabled, ICSP Bulk Erase (all program memory erased) operations can be used to disable code protection. ICSP Row Erase operations cannot be used to disable code protection.

TABLE 3-2: ERASE CODE MEMORY CODE SEQUENCE

4-Bit Command	Data Payload	Core Instruction
Step 1: Enable memory writes.		
0000	84 A6	BSF EECON1, WREN
Step 2: Point to first row in code memory.		
0000	6A F8	CLRF TBLPTRU
0000	6A F7	CLRF TBLPTRH
0000	6A F6	CLRF TBLPTRL
Step 3: Enable erase and erase single row.		
0000	88 A6	BSF EECON1, FREE
0000	82 A6	BSF EECON1, WR
0000	00 00	NOP - hold PGC high for time P10.
Step 4: Repeat Step 3, with Address Pointer incremented by 1024, until all rows are erased.		

FIGURE 3-3: SET WR AND START ROW ERASE TIMING

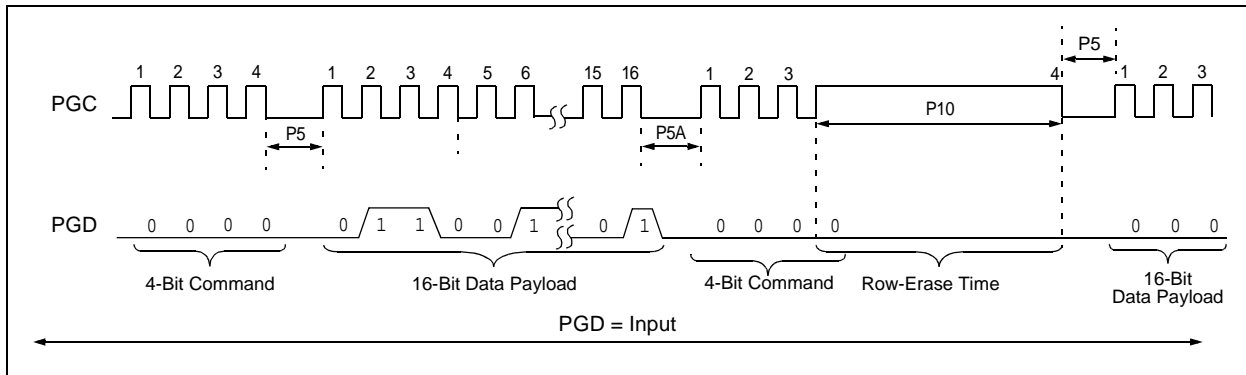

PIC18F2XJXX/4XJXX FAMILY

FIGURE 3-4: SINGLE ROW ERASE CODE MEMORY FLOW

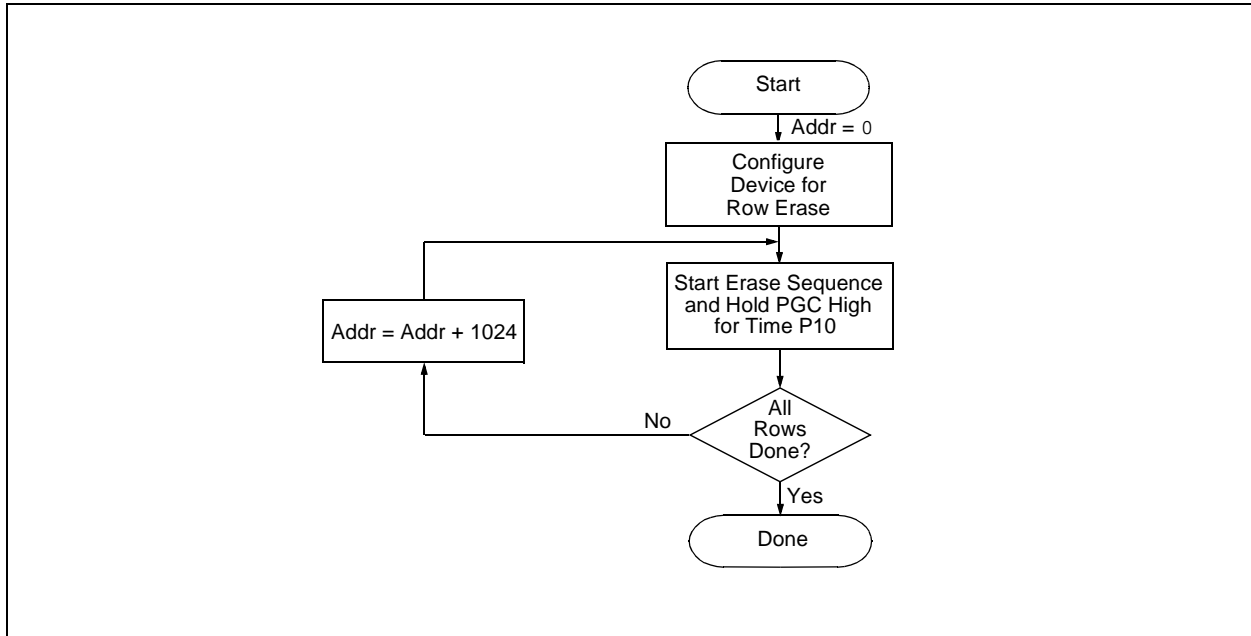

PIC18F2XJXX/4XJXX FAMILY

FIGURE 3-5: PROGRAM CODE MEMORY FLOW

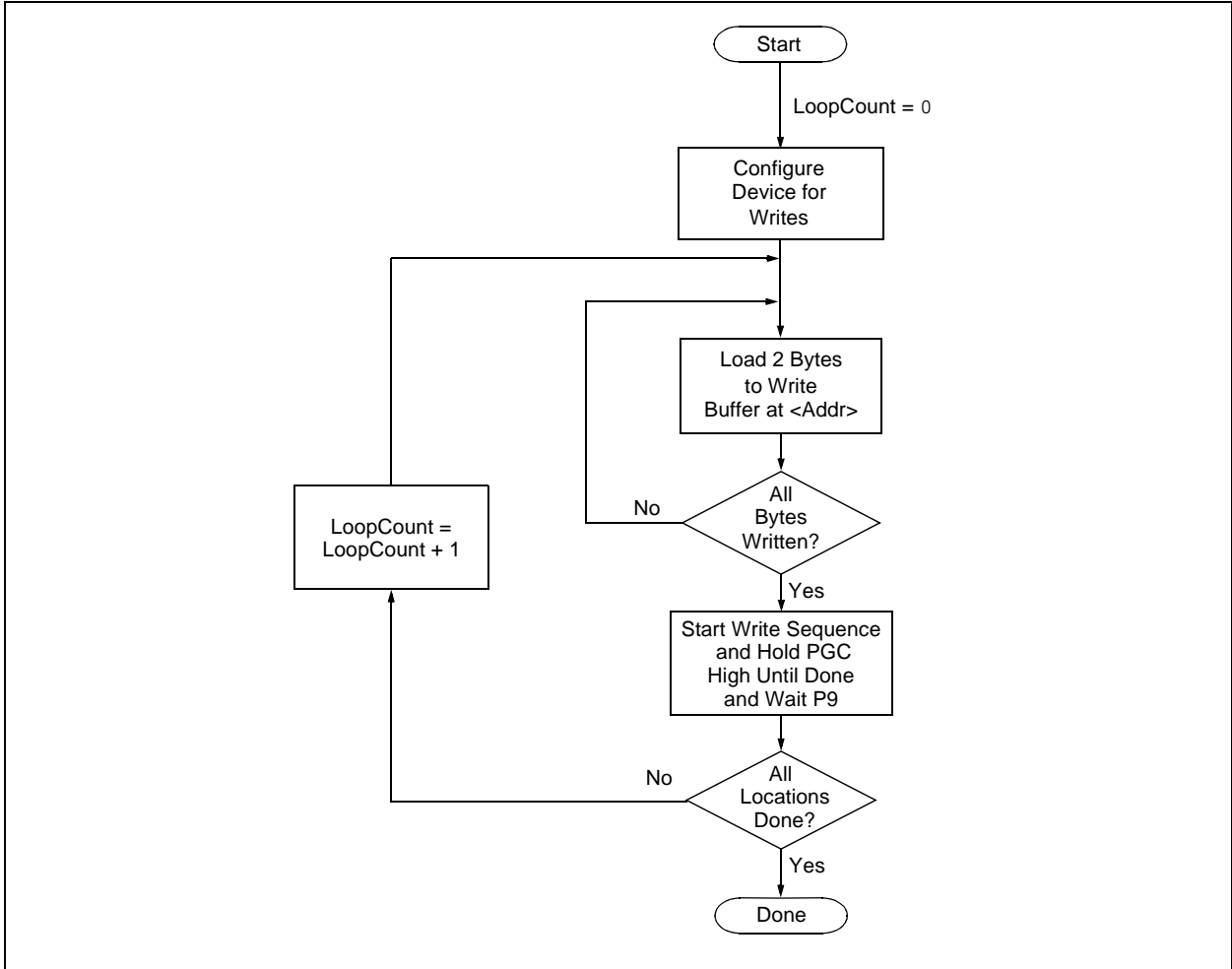
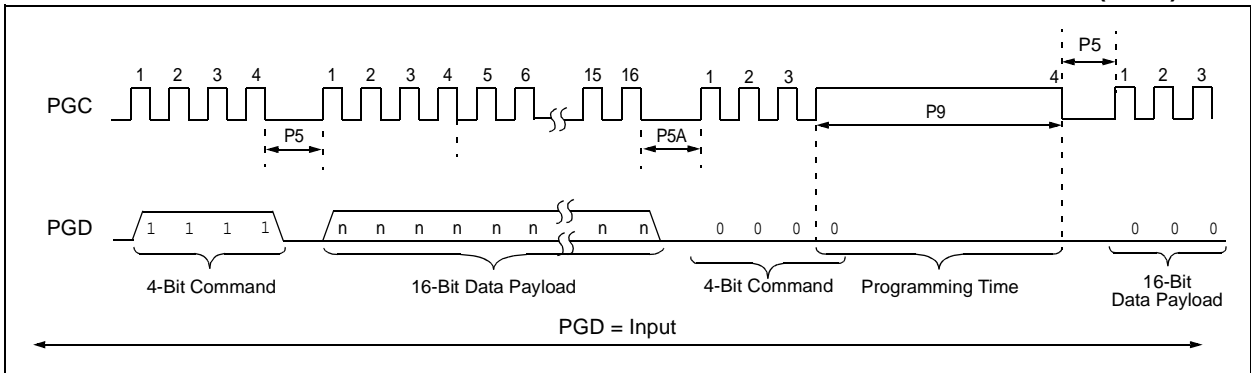

FIGURE 3-6: TABLE WRITE AND START PROGRAMMING INSTRUCTION TIMING (1111)



PIC18F2XJXX/4XJXX FAMILY

3.2.1 MODIFYING CODE MEMORY

The previous programming example assumed that the device had been Bulk Erased prior to programming. It may be the case, however, that the user wishes to modify only a section of an already programmed device.

As described in **Section 4.2 “Verify Code Memory and Configuration Word”**, the appropriate number of bytes required for the erase buffer must be read out of code memory and buffered. Modifications can be made on this buffer. Then, the block of code memory that was read out must be erased and rewritten with the modified data. The code sequence is shown in Table 3-4.

The WREN bit must be set if the WR bit in EECON1 is used to initiate a write sequence.

3.2.2 CONFIGURATION WORD PROGRAMMING

Since the Flash Configuration Words are stored in program memory, they are programmed as if they were program data. Refer to **Section 3.2 “Code Memory Programming”** and **Section 3.2.1 “Modifying Code Memory”** for methods and examples on programming or modifying program memory. See also **Section 5.0 “Configuration Word”** for additional information on the Configuration Words.

TABLE 3-4: MODIFYING CODE MEMORY

4-Bit Command	Data Payload	Core Instruction
Step 1: Set the Table Pointer for the block to be erased.		
0000	0E <Addr[21:16]>	MOVLW <Addr[21:16]>
0000	6E F8	MOVWF TBLPTRU
0000	0E <Addr[8:15]>	MOVLW <Addr[8:15]>
0000	6E F7	MOVWF TBLPTRH
0000	0E <Addr[7:0]>	MOVLW <Addr[7:0]>
0000	6E F6	MOVWF TBLPTRL
Step 2: Read and modify code memory (see Section 4.1 “Read Code Memory”).		
Step 3: Enable memory writes and set up an erase.		
0000	84 A6	BSF EECON1, WREN
0000	88 A6	BSF EECON1, FREE
Step 4: Initiate erase.		
0000	82 A6	BSF EECON1, WR
0000	00 00	NOP - hold PGC high for time P10.
Step 5: Load write buffer. The correct bytes will be selected based on the Table Pointer.		
0000	0E <Addr[21:16]>	MOVLW <Addr[21:16]>
0000	6E F8	MOVWF TBLPTRU
0000	0E <Addr[8:15]>	MOVLW <Addr[8:15]>
0000	6E F7	MOVWF TBLPTRH
0000	0E <Addr[7:0]>	MOVLW <Addr[7:0]>
0000	6E F6	MOVWF TBLPTRL
1101	<MSB><LSB>	Write 2 bytes and post-increment address by 2.
.	.	Repeat write operation 30 more times to fill the write buffer
.	.	
.	.	
1111	<MSB><LSB>	Write 2 bytes and start programming.
0000	00 00	NOP - hold PGC high for time P9.
Step 6: Repeat Step 5 for a total of 16 times (if rewriting the entire 1024 bytes of the erase page size).		
Step 7: To continue modifying data, repeat Steps 1 through 5, where the Address Pointer is incremented by 1024 bytes at each iteration of the loop.		
Step 8: Disable writes.		
0000	94 A6	BCF EECON1, WREN

PIC18F2XJXX/4XJXX FAMILY

4.0 READING THE DEVICE

4.1 Read Code Memory

Code memory is accessed one byte at a time via the 4-bit command, '1001' (table read, post-increment). The contents of memory pointed to by the Table Pointer (TBLPTRU:TBLPTRH:TBLPTRL) are serially output on PGD.

The 4-bit command is shifted in LSb first. The read is executed during the next eight clocks, then shifted out on PGD during the last eight clocks, LSb to MSb. A

delay of P6 must be introduced after the falling edge of the 8th PGC of the operand to allow PGD to transition from an input to an output. During this time, PGC must be held low (see Figure 4-1). This operation also increments the Table Pointer by one, pointing to the next byte in code memory for the next read.

This technique will work to read any memory in the 000000h to 3FFFFFFh address space, so it also applies to reading the Configuration registers.

TABLE 4-1: READ CODE MEMORY SEQUENCE

4-Bit Command	Data Payload	Core Instruction
Step 1: Set Table Pointer.		
0000	0E <Addr[21:16]>	MOVLW Addr[21:16]
0000	6E F8	MOVWF TBLPTRU
0000	0E <Addr[15:8]>	MOVLW <Addr[15:8]>
0000	6E F7	MOVWF TBLPTRH
0000	0E <Addr[7:0]>	MOVLW <Addr[7:0]>
0000	6E F6	MOVWF TBLPTRL
Step 2: Read memory and then shift out on PGD, LSb to MSb.		
1001	00 00	TBLRD *+

FIGURE 4-1: TABLE READ, POST-INCREMENT INSTRUCTION TIMING (1001)

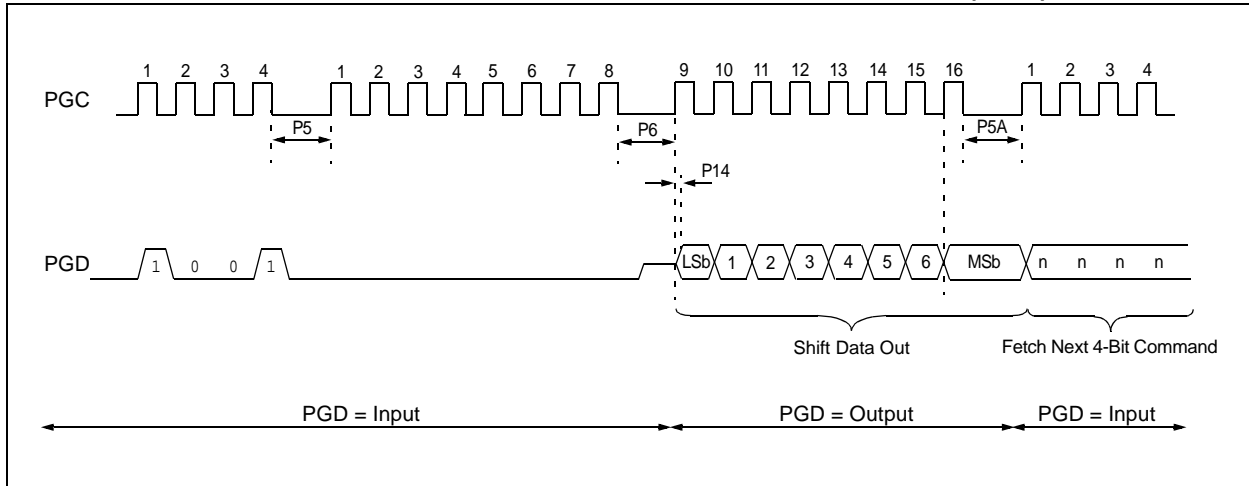

PIC18F2XJXX/4XJXX FAMILY

4.2 Verify Code Memory and Configuration Word

The verify step involves reading back the code memory space and comparing it against the copy held in the programmer's buffer. Because the Flash Configuration Words are stored at the end of program memory, it is verified with the rest of the code at this time.

The verify process is shown in the flowchart in Figure 4-2. Memory reads occur a single byte at a time, so two bytes must be read to compare against the word in the programmer's buffer. Refer to **Section 4.1 "Read Code Memory"** for implementation details of reading code memory.

Note 1: Because the Flash Configuration Word contains the device code protection bit, code memory should be verified immediately after writing if code protection is enabled. This is because the device will not be readable or verifiable if a device Reset occurs after the Flash Configuration Words (and the CP0 bit) have been cleared.

FIGURE 4-2: VERIFY CODE MEMORY FLOW

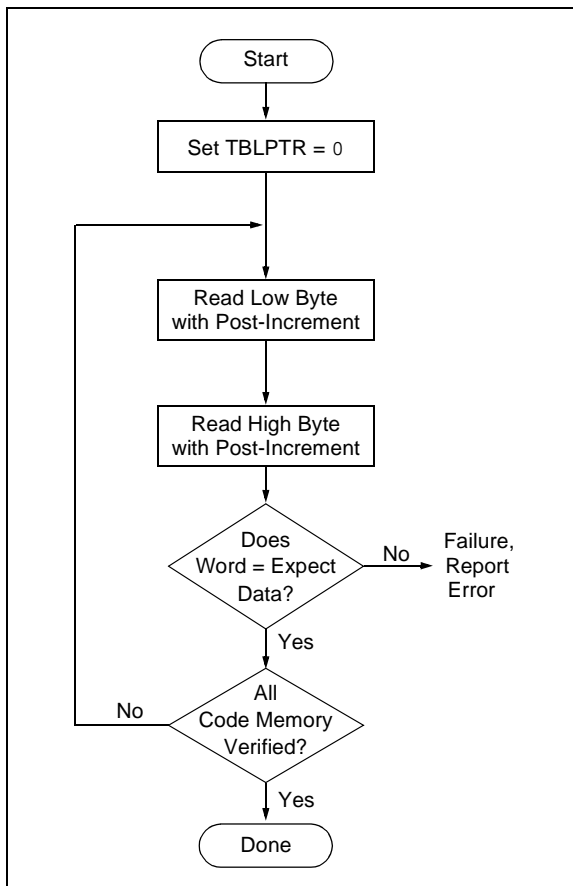

4.3 Blank Check

The term Blank Check means to verify that the device has no programmed memory cells. All memories, code memory and Configuration bits, must be verified. The Device ID registers (3FFFFEh:3FFFFFFh) should be ignored.

A "blank" or "erased" memory cell will read as a '1', so Blank Checking a device merely means to verify that all bytes read as FFh. The overall process flow is shown in Figure 4-3.

Blank Checking is merely code verification with FFh expect data. For implementation details, refer to **Section 4.2 "Verify Code Memory and Configuration Word"**.

FIGURE 4-3: BLANK CHECK FLOW

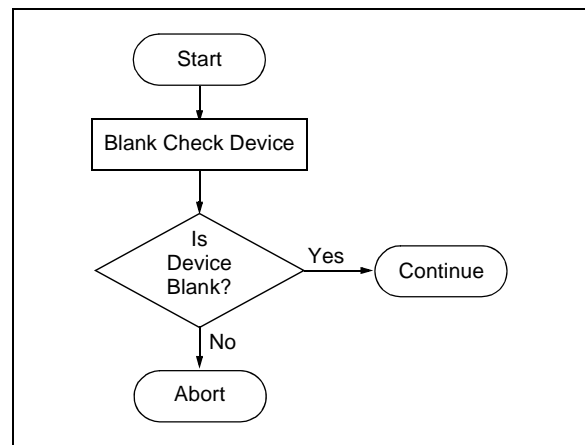

PIC18F2XJXX/4XJXX FAMILY

5.0 CONFIGURATION WORD

The Configuration Words of the PIC18F2XJXX/4XJXX Family devices are implemented as volatile memory registers. All of the Configuration registers (CONFIG1L, CONFIG1H, CONFIG2L, CONFIG2H, CONFIG3L, CONFIG3H, CONFIG4L, and CONFIG4H) are automatically loaded following each device Reset.

The data for these registers is taken from the four Flash Configuration Words located at the end of program memory. Configuration data is stored in order, starting with CONFIG1L in the lowest Flash address and ending with CONFIG4H in the highest. The mapping to specific Configuration Words is shown in Table 5-1. Users should always reserve these locations for Configuration Word data and write their application code accordingly.

The upper four bits of each Flash Configuration Word should always be stored in program memory as '1111'. This is done so these program memory addresses will always be '1111 xxxx xxxx xxxx' and interpreted as a NOP instruction if they were ever to be executed. Because the corresponding bits in the Configuration registers are unimplemented, they will not change the device's configuration.

The Configuration and Device ID registers are summarized in Table 5-2. A listing of the individual Configuration bits and their options is provided in Table 5-3.

TABLE 5-1: MAPPING OF THE FLASH CONFIGURATION WORDS TO THE CONFIGURATION REGISTERS

Configuration Register	Flash Configuration Byte ⁽¹⁾	Configuration Register Address
CONFIG1L	XFF8h	300000h
CONFIG1H	XFF9h	300001h
CONFIG2L	XFFAh	300002h
CONFIG2H	XFFBh	300003h
CONFIG3L	XFFCh	300004h
CONFIG3H	XFFDh	300005h
CONFIG4L ⁽²⁾	XFFEh	300006h
CONFIG4H ⁽²⁾	XFFFh	300007h

Note 1: See Table 2-2 for the complete addresses within code space for specific devices and memory sizes.

2: Unimplemented in PIC18F45J10 family devices.

TABLE 5-2: PIC18F45J10 FAMILY DEVICES: CONFIGURATION BITS AND DEVICE IDs

File Name	Bit 7	Bit 6	Bit 5	Bit 4	Bit 3	Bit 2	Bit 1	Bit 0	Default/ Unprogrammed Value	
300000h	CONFIG1L	$\overline{\text{DEBUG}}$	XINST	STVREN	—	—	—	WDTEN	111- ---1	
300001h	CONFIG1H	— ⁽¹⁾	— ⁽¹⁾	— ⁽¹⁾	— ⁽¹⁾	— ⁽²⁾	CP0	—	---- 01--	
300002h	CONFIG2L	IESO	FCMEN	—	—	—	FOSC2	FOSC1	FOSC0	11-- -111
300003h	CONFIG2H	— ⁽¹⁾	— ⁽¹⁾	— ⁽¹⁾	— ⁽¹⁾	WDTPS3	WDTPS2	WDTPS1	WDTPS0	---- 1111
300005h	CONFIG3H	— ⁽¹⁾	— ⁽¹⁾	— ⁽¹⁾	— ⁽¹⁾	—	—	—	CCP2MX	---- ---1
3FFFFEh	DEVID1 ⁽³⁾	DEV2	DEV1	DEV0	REV4	REV3	REV2	REV1	REV0	See Table
3FFFFFh	DEVID2 ⁽³⁾	DEV10	DEV9	DEV8	DEV7	DEV6	DEV5	DEV4	DEV3	See Table

Legend: — = unimplemented. Shaded cells are unimplemented, read as '0'.

Note 1: The value of these bits in program memory should always be '1'. This ensures that the location is executed as a NOP if it is accidentally executed.

2: This bit should always be maintained at '0'.

3: DEVID registers are read-only and cannot be programmed by the user.

PIC18F2XJXX/4XJXX FAMILY

TABLE 5-3: PIC18F45J10 FAMILY DEVICES: BIT DESCRIPTIONS

Bit Name	Configuration Words	Description
DEBUG	CONFIG1L	Background Debugger Enable bit 1 = Background debugger disabled, RB6 and RB7 configured as general purpose I/O pins 0 = Background debugger enabled, RB6 and RB7 are dedicated to in-circuit debug
XINST	CONFIG1L	Extended Instruction Set Enable bit 1 = Instruction set extension and Indexed Addressing mode enabled 0 = Instruction set extension and Indexed Addressing mode disabled (Legacy mode)
STVREN	CONFIG1L	Stack Overflow/Underflow Reset Enable bit 1 = Reset on stack overflow/underflow enabled 0 = Reset on stack overflow/underflow disabled
WDTEN	CONFIG1L	Watchdog Timer Enable bit 1 = WDT enabled 0 = WDT disabled (control is placed on SWDTEN bit)
CP0	CONFIG1H	Code Protection bit 1 = Program memory is not code-protected 0 = Program memory is code-protected
IESO	CONFIG2L	Internal/External Oscillator Switchover bit 1 = Oscillator Switchover mode enabled 0 = Oscillator Switchover mode disabled
FCMEN	CONFIG2L	Fail-Safe Clock Monitor Enable bit 1 = Fail-Safe Clock Monitor enabled 0 = Fail-Safe Clock Monitor disabled
FOSC2	CONFIG2L	Default Oscillator Select bit 1 = Clock designated by FOSC<1:0> is enabled as system clock when OSCCON<1:0> = 00 0 = INTRC is enabled as system clock when OSCCON<1:0> = 00
FOSC<1:0>	CONFIG2L	Primary Oscillator Select bits 11 = EC oscillator, PLL enabled and under software control, CLKO function on OSC2 10 = EC oscillator, CLKO function on OSC2 01 = HS oscillator, PLL enabled and under software control 00 = HS oscillator
WDTPS<3:0>	CONFIG2H	Watchdog Timer Postscale Select bits 1111 = 1:32,768 1110 = 1:16,384 1101 = 1:8,192 1100 = 1:4,096 1011 = 1:2,048 1010 = 1:1,024 1001 = 1:512 1000 = 1:256 0111 = 1:128 0110 = 1:64 0101 = 1:32 0100 = 1:16 0011 = 1:8 0010 = 1:4 0001 = 1:2 0000 = 1:1
CCP2MX	CONFIG3H	CCP2 MUX bit 1 = CCP2 is multiplexed with RC1 0 = CCP2 is multiplexed with RB3

PIC18F2XJXX/4XJXX FAMILY

TABLE 5-4: PIC18F46J11 AND PIC18F46J50 FAMILY DEVICES: CONFIGURATION BITS AND DEVICE IDS

File Name	Bit 7	Bit 6	Bit 5	Bit 4	Bit 3	Bit 2	Bit 1	Bit 0	Default/ Unprogrammed Value ⁽¹⁾
300000h CONFIG1L	DEBUG	XINST	STVREN	—	PLLDIV2 ⁽³⁾	PLLDIV1 ⁽³⁾	PLLDIV0 ⁽³⁾	WDTEN	111- 1111
300001h CONFIG1H	— ⁽²⁾	— ⁽²⁾	— ⁽²⁾	— ⁽²⁾	— ⁽⁴⁾	CP0	CPDIV1 ⁽³⁾	CPDIV0 ⁽³⁾	---- 0111
300002h CONFIG2L	IESO	FCMEN	—	LPT1OSC	T1DIG	FOSC2	FOSC1	FOSC0	11-1 1111
300003h CONFIG2H	— ⁽²⁾	— ⁽²⁾	— ⁽²⁾	— ⁽²⁾	WDTPS3	WDTPS2	WDTPS1	WDTPS0	---- 1111
300004h CONFIG3L	DSWDTPS3	DSWDTPS2	DSWDTPS1	DSWDTPS0	DSWDTEN	DSBOREN	RTCOSC	DSWDTOSC	1111 1111
300005h CONFIG3H	— ⁽²⁾	— ⁽²⁾	— ⁽²⁾	— ⁽²⁾	MSSPSMSK	—	—	IOL1WAY	---- 1--1
300006h CONFIG4L	WPCFG	WPEND	WPPFP5 ⁽⁵⁾	WPPFP4 ⁽⁶⁾	WPPFP3	WPPFP2	WPPFP1	WPPFP0	1111 1111
300007h CONFIG4H	— ⁽²⁾	— ⁽²⁾	— ⁽²⁾	— ⁽²⁾	—	—	—	WPDIS	---- --1
3FFFFEh DEVID1	DEV2	DEV1	DEV0	REV4	REV3	REV2	REV1	REV0	xxxx xxxx
3FFFFFh DEVID2	DEV10	DEV9	DEV8	DEV7	DEV6	DEV5	DEV4	DEV3	0100 00xx

- Legend:** x = unknown, u = unchanged, - = unimplemented. Shaded cells are unimplemented, read as '0'.
- Note 1:** Values reflect the unprogrammed state as received from the factory and following Power-on Resets. In all other Reset states, the configuration bytes maintain their previously programmed states.
- 2:** The value of these bits in program memory should always be '1'. This ensures that the location is executed as a NOP if it is accidentally executed.
- 3:** These bits are not implemented in PIC18F46J11 family devices.
- 4:** This bit should always be maintained at '0'.
- 5:** This bit is not available on 32K and 16K memory devices (X4J11, X4J50, X5J11, and X5J50 devices) and should always be maintained at '0' on those devices.
- 6:** This bit is not available on 16K memory devices (X4J11 and X4J50 devices) and should always be maintained at '0' on those devices.

TABLE 5-5: PIC18F46J11 AND PIC18F46J50 FAMILY DEVICES: BIT DESCRIPTIONS

Bit Name	Configuration Words	Description
DEBUG	CONFIG1L	Background Debugger Enable bit 1 = Background debugger disabled, RB6 and RB7 configured as general purpose I/O pins 0 = Background debugger enabled, RB6 and RB7 are dedicated to in-circuit debug
XINST	CONFIG1L	Enhanced Instruction Set Enable bit 1 = Instruction set extension and Indexed Addressing mode enabled 0 = Instruction set extension and Indexed Addressing mode disabled (Legacy mode)
STVREN	CONFIG1L	Stack Overflow/Underflow Reset Enable bit 1 = Reset on stack overflow/underflow enabled 0 = Reset on stack overflow/underflow disabled
PLLDIV<2:0> ⁽³⁾	CONFIG1L	PLL Input Divider bits Divider must be selected to provide a 4 MHz input into the 96 MHz PLL. 111 = No divide – oscillator used directly (4 MHz input) 110 = Oscillator divided by 2 (8 MHz input) 101 = Oscillator divided by 3 (12 MHz input) 100 = Oscillator divided by 4 (16 MHz input) 011 = Oscillator divided by 5 (20 MHz input) 010 = Oscillator divided by 6 (24 MHz input) 001 = Oscillator divided by 10 (40 MHz input) 000 = Oscillator divided by 12 (48 MHz input)
WDTEN	CONFIG1L	Watchdog Timer Enable bit 1 = WDT enabled 0 = WDT disabled (control is placed on SWDTEN bit)

- Note 1:** The Configuration bits can only be programmed indirectly by programming the Flash Configuration Word.
- 2:** The Configuration bits are reset to '1' only on VDD Reset; it is reloaded with the programmed value at any device Reset.
- 3:** These bits are not implemented in PIC18F46J11 family devices.
- 4:** Once this bit is cleared, all the Configuration registers which reside in the last page are also protected. To disable code protection, perform an ICSP™ Bulk Erase operation.

PIC18F2XJXX/4XJXX FAMILY

TABLE 5-5: PIC18F46J11 AND PIC18F46J50 FAMILY DEVICES: BIT DESCRIPTIONS (CONTINUED)

Bit Name	Configuration Words	Description
DSWTPS<3:0>	CONFIG3L	Deep Sleep Watchdog Timer Postscale Select bits The DSWDT prescaler is 32; this creates an approximate base time unit of 1 ms. 1111 = 1:2,147,483,648 (25.7 days) 1110 = 1:536,870,912 (6.4 days) 1101 = 1:134,217,728 (38.5 hours) 1100 = 1:33,554,432 (9.6 hours) 1011 = 1:8,388,608 (2.4 hours) 1010 = 1:2,097,152 (36 minutes) 1001 = 1:524,288 (9 minutes) 1000 = 1:131,072 (135 seconds) 0111 = 1:32,768 (34 seconds) 0110 = 1:8,192 (8.5 seconds) 0101 = 1:2,048 (2.1 seconds) 0100 = 1:512 (528 ms) 0011 = 1:128 (132 ms) 0010 = 1:32 (33 ms) 0001 = 1:8 (8.3 ms) 0000 = 1:2 (2.1 ms)
DSWDTEN	CONFIG3L	Deep Sleep Watchdog Timer Enable bit 1 = DSWDT enabled 0 = DSWDT disabled
DSBOREN	CONFIG3L	Deep Sleep BOR Enable bit 1 = BOR enabled in Deep Sleep 0 = BOR disabled in Deep Sleep (does not affect operation in non Deep Sleep modes)
RTCOSC	CONFIG3L	RTCC Reference Clock Select bit 1 = RTCC uses T1OSC/T1CKI as reference clock 0 = RTCC uses INTRC as reference clock
DSWDTOSC	CONFIG3L	DSWDT Reference Clock Select bit 1 = DSWDT uses INTRC as reference clock 0 = DSWDT uses T1OSC/T1CKI as reference clock
MSSPMSK ^(1,2)	CONFIG3H	MSSP 7-Bit Address Masking Mode Enable bit 1 = 7-Bit Address Masking mode enable 0 = 5-Bit Address Masking mode enable
IOL1WAY	CONFIG3H	IOLOCK Bit One-Way Set Enable bit 1 = The IOLOCK bit (PPSCON<0>) can be set once, provided the unlock sequence has been completed. Once set, the Peripheral Pin Select registers cannot be written to a second time. 0 = The IOLOCK bit (PPSCON<0>) can be set and cleared as needed, provided the unlock sequence has been completed.
WPCFG ⁽⁴⁾	CONFIG4L	Write/Erase Protect Configuration Words Page bit (valid when WPDIS = 0) 1 = Configuration Words page is not erase/write-protected unless WPEND and WPPF<5:0> settings include the Configuration Words page 0 = Configuration Words page is erase/write-protected, regardless of WPEND and WPPF<5:0> settings
WPEND	CONFIG4L	Write/Erase Protect Region Select bit (valid when WPDIS = 0) 1 = Flash pages, WPPF<5:0> to Configuration Words page, are write/erase-protected 0 = Flash pages, 0 to WPPF<5:0> are write/erase-protected

- Note 1:** The Configuration bits can only be programmed indirectly by programming the Flash Configuration Word.
Note 2: The Configuration bits are reset to '1' only on VDD Reset; it is reloaded with the programmed value at any device Reset.
Note 3: These bits are not implemented in PIC18F46J11 family devices.
Note 4: Once this bit is cleared, all the Configuration registers which reside in the last page are also protected. To disable code protection, perform an ICSP™ Bulk Erase operation.

PIC18F2XJXX/4XJXX FAMILY

TABLE 5-5: PIC18F46J11 AND PIC18F46J50 FAMILY DEVICES: BIT DESCRIPTIONS (CONTINUED)

Bit Name	Configuration Words	Description
WPPF<5:0>	CONFIG4L	Write/Erase Protect Page Start/End Location bits Used with WPEND bit to define which pages in Flash will be write/erase-protected.
WPDIS	CONFIG4H	Write Protect Disable bit 1 = WPPF<5:0>, WPEND and WPCFG bits ignored; all Flash memory may be erased or written 0 = WPPF<5:0>, WPEND and WPCFG bits enabled; write/erase-protect active for the selected region(s)
DEV<2:0>	DEVID1	Device ID bits Used with the DEV<10:3> bits in the Device ID Register 2 to identify the part number.
REV<4:0>	DEVID1	Revision ID bits Indicate the device revision.
DEV<10:3>	DEVID2	Device ID bits Used with the DEV<2:0> bits in the Device ID Register 1 to identify the part number.

- Note 1:** The Configuration bits can only be programmed indirectly by programming the Flash Configuration Word.
Note 2: The Configuration bits are reset to '1' only on VDD Reset; it is reloaded with the programmed value at any device Reset.
Note 3: These bits are not implemented in PIC18F46J11 family devices.
Note 4: Once this bit is cleared, all the Configuration registers which reside in the last page are also protected. To disable code protection, perform an ICSP™ Bulk Erase operation.

TABLE 5-6: PIC18F47J13 AND PIC18F47J53 FAMILY DEVICES: CONFIGURATION BITS AND DEVICE IDs

File Name	Bit 7	Bit 6	Bit 5	Bit 4	Bit 3	Bit 2	Bit 1	Bit 0	Default/ Unprogrammed Value ⁽¹⁾	
300000h	CONFIG1L	DEBUG	XINST	STVREN	CFGPLLEN	PLLDIV2	PLLDIV1	PLLDIV0	WDTEN	111- 1111
300001h	CONFIG1H	_(2)	_(2)	_(2)	_(2)	_(4)	CP0	CPDIV1 ⁽³⁾	CPDIV0 ⁽³⁾	---- 0111
300002h	CONFIG2L	IESO	FCMEN	CLKOEC	SOSCSEL1	SOSCSEL0	FOSC2	FOSC1	FOSC0	1111 1111
300003h	CONFIG2H	_(2)	_(2)	_(2)	_(2)	WDTPS3	WDTPS2	WDTPS1	WDTPS0	---- 1111
300004h	CONFIG3L	DSWDTPS3	DSWDTPS2	DSWDTPS1	DSWDTPS0	DSWDTEN	DSBOREN	RTCOSC	DSWDTOSC	1111 1111
300005h	CONFIG3H	_(2)	_(2)	_(2)	_(2)	MSSPMSK	PLLSEL	ADCSEL	IOL1WAY	---- 1111
300006h	CONFIG4L	WPCFG	WPPF6	WPPF5	WPPF4	WPPF3	WPPF2	WPPF1	WPPF0	1111 1111
300007h	CONFIG4H	_(2)	_(2)	_(2)	_(2)	LS48MHZ ⁽³⁾	—	WPEND	WPDIS	---- 1-11
3FFFFEh	DEVID1	DEV2	DEV1	DEV0	REV4	REV3	REV2	REV1	REV0	xxxx xxxx
3FFFFFh	DEVID2	DEV10	DEV9	DEV8	DEV7	DEV6	DEV5	DEV4	DEV3	0101 10xx

- Legend:** x = unknown, u = unchanged, - = unimplemented. Shaded cells are unimplemented, read as '0'.
Note 1: Values reflect the unprogrammed state as received from the factory and following Power-on Resets. In all other Reset states, the configuration bytes maintain their previously programmed states.
Note 2: The value of these bits in program memory should always be '1'. This ensures that the location is executed as a NOP if it is accidentally executed.
Note 3: These bits are not implemented in PIC18F47J13 family devices.
Note 4: This bit should always be maintained at '0'.

PIC18F2XJXX/4XJXX FAMILY

5.1 Device ID Word

The Device ID Word for the PIC18F2XJXX/4XJXX Family devices is located at 3FFFFEh:3FFFFFh. These read-only bits may be used by the programmer to identify what device type is being programmed and read out normally, even after code protection has been enabled. The process for reading the Device IDs is shown in Figure 5-1. A complete list of Device ID values for the PIC18F2XJXX/4XJXX Family is presented in Table 5-8.

FIGURE 5-1: READ DEVICE ID WORD FLOW

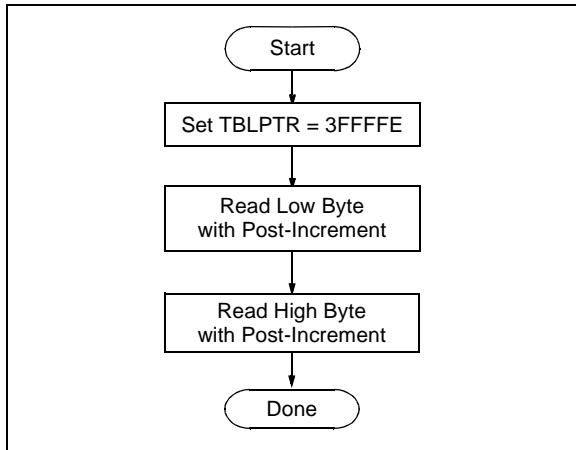

TABLE 5-8: DEVICE ID VALUE

Device	Device ID Value	
	DEVID2	DEVID1
PIC18F24J10	1Dh	000x xxxx
PIC18F25J10	1Ch	000x xxxx
PIC18F44J10	1Dh	001x xxxx
PIC18F45J10	1Ch	001x xxxx
PIC18LF24J10	1Dh	010x xxxx
PIC18LF25J10	1Ch	010x xxxx
PIC18LF44J10	1Dh	011x xxxx
PIC18LF45J10	1Ch	011x xxxx
PIC18F25J11	4Dh	101x xxxx
PIC18F24J11	4Dh	100x xxxx
PIC18F26J11	4Dh	110x xxxx
PIC18F45J11	4Eh	000x xxxx
PIC18F44J11	4Dh	111x xxxx
PIC18F46J11	4Eh	001x xxxx
PIC18F24J50	4Ch	000x xxxx
PIC18F25J50	4Ch	001x xxxx
PIC18F26J50	4Ch	010x xxxx
PIC18F44J50	4Ch	011x xxxx
PIC18F45J50	4Ch	100x xxxx

TABLE 5-8: DEVICE ID VALUE (CONTINUED)

Device	Device ID Value	
	DEVID2	DEVID1
PIC18F46J50	4Ch	101x xxxx
PIC18LF2450	4Ch	110x xxxx
PIC18LF25J50	4Ch	111x xxxx
PIC18LF26J50	4Dh	000x xxxx
PIC18LF44J50	4Dh	001x xxxx
PIC18LF45J50	4Dh	010x xxxx
PIC18LF46J50	4Dh	011x xxxx
PIC18LF24J11	4Eh	010x xxxx
PIC18LF25J11	4Eh	011x xxxx
PIC18LF26J11	4Eh	100x xxxx
PIC18LF44J11	4Eh	101x xxxx
PIC18LF45J11	4Eh	110x xxxx
PIC18LF46J11	4Eh	111x xxxx
PIC18F26J13	59h	001x xxxx
PIC18F27J13	59h	011x xxxx
PIC18F46J13	59h	101x xxxx
PIC18F47J13	59h	111x xxxx
PIC18LF26J13	5Bh	001x xxxx
PIC18LF27J13	5Bh	011x xxxx
PIC18LF46J13	5Bh	101x xxxx
PIC18LF47J13	5Bh	111x xxxx
PIC18F26J53	58h	001x xxxx
PIC18F27J53	58h	011x xxxx
PIC18F46J53	58h	101x xxxx
PIC18F47J53	58h	111x xxxx
PIC18LF26J53	5Ah	001x xxxx
PIC18LF27J53	5Ah	011x xxxx
PIC18LF46J53	5Ah	101x xxxx
PIC18LF47J53	5Ah	111x xxxx

5.2 Checksum Computation

The checksum is calculated by summing the contents of all code memory locations and the device Configuration Words, appropriately masked. The Least Significant 16 bits of this sum are the checksum.

The checksum calculation differs depending on whether or not code protection is enabled. Since the code memory locations read out differently depending on the code-protect setting, the table describes how to manipulate the actual code memory values to simulate the values that would be read from a protected device. When calculating a checksum by reading a device, the entire code memory can simply be read and summed. The Configuration Words can always be read.

PIC18F2XJXX/4XJXX FAMILY

6.0 AC/DC CHARACTERISTICS TIMING REQUIREMENTS FOR PROGRAM/VERIFY TEST MODE

Standard Operating Conditions								
Operating Temperature: 25°C is recommended								
Param No.	Symbol	Characteristic	Min.	Max.	Units	Conditions		
	VDDCORE	External Supply Voltage for Microcontroller Core During Programming Operations (PIC18LF devices)	2.25	2.75	V	(Note 1)		
D111	VDD	Supply Voltage During Programming	PIC18LFXXJXX	VDDCORE	3.60	V	Normal programming (Note 2)	
			PIC18FXXJ10		2.70	3.60		V
			PIC18FXXJ50		2.35	3.60	V	
			PIC18FXXJ11					
			PIC18FXXJ53 PIC18FXXJ13					
D112	I _{PP}	Programming Current on $\overline{\text{MCLR}}$	—	5	μA			
D113	I _{DDP}	Supply Current During Programming	—	10	mA			
D031	V _{IL}	Input Low Voltage	V _{SS}	0.2 V _{DD}	V			
D041	V _{IH}	Input High Voltage	0.8 V _{DD}	V _{DD}	V			
D080	V _{OL}	Output Low Voltage	—	0.4	V	I _{OL} = 3.4 mA @ 3.3V		
D090	V _{OH}	Output High Voltage	2.4	—	V	I _{OH} = -2.0 mA @ 3.3V		
D012	C _{IO}	Capacitive Loading on I/O pin (PGD)	—	50	pF	To meet AC specifications		
	C _F	Filter Capacitor Value on V _{CAP}	PIC18LFXXJXX	0.1	—	μF	(Note 1)	
			PIC18FXXJ10	4.7	18	μF		
			PIC18FXXJ13	5.4	18	μF		
			PIC18FXXJ11					
			PIC18FXXJ5X					

Note 1: External power must be supplied to the VDDCORE/V_{CAP} pin if the on-chip voltage regulator is disabled. See Section 2.1.1 “PIC18F2XJXX/4XJXX/ LF2XJXX/LF4XJXX Devices and the On-Chip Voltage Regulator” for more information.

2: VDD must also be supplied to the AVDD pins during programming. AVDD and AVSS should always be within ±0.3V of VDD and VSS, respectively.

PIC18F2XJXX/4XJXX FAMILY

6.0 AC/DC CHARACTERISTICS TIMING REQUIREMENTS FOR PROGRAM/VERIFY TEST MODE (CONTINUED)

Standard Operating Conditions						
Operating Temperature: 25°C is recommended						
Param No.	Symbol	Characteristic	Min.	Max.	Units	Conditions
P1	TR	MCLR Rise Time to Enter Program/Verify mode	—	1.0	μs	
P2	TPGC	Serial Clock (PGC) Period	100	—	ns	
P2A	TPGCL	Serial Clock (PGC) Low Time	50	—	ns	
P2B	TPGCH	Serial Clock (PGC) High Time	50	—	ns	
P3	TSET1	Input Data Setup Time to Serial Clock ↓	20	—	ns	
P4	THLD1	Input Data Hold Time from PGC ↓	20	—	ns	
P5	TDLY1	Delay Between 4-Bit Command and Command Operand	50	—	ns	
P5A	TDLY1A	Delay Between 4-Bit Command Operand and Next 4-Bit Command	50	—	ns	
P6	TDLY2	Delay Between Last PGC ↓ of Command Byte to First PGC ↑ of Read of Data Word	20	—	ns	
P9	TDLY5	Delay to allow Block Programming to occur	3.4	—	ms	PIC18F2XJ10/PIC18F4XJ10
			1.2	—	ms	PIC18F2XJ11/PIC18F4XJ11/ PIC18F2XJ13/PIC18F4XJ13/ PIC18F2XJ5X/PIC18F4XJ5X
P10	TDLY6	Delay to allow Row Erase to occur	49	—	ms	PIC18F2XJ10/PIC18F4XJ10/ PIC18F2XJ13/PIC18F4XJ13/ PIC18F2XJ53/PIC18F4XJ53
			54	—	ms	PIC18F2XJ11/PIC18F4XJ11/ PIC18F2XJ50/PIC18F4XJ50
P11	TDLY7	Delay to allow Bulk Erase to occur	475	—	ms	PIC18F2XJ10/PIC18F4XJ10/ PIC18F2XJ13/PIC18F4XJ13/ PIC18F2XJ53/PIC18F4XJ53
			524	—	ms	PIC18F2XJ11/PIC18F4XJ11/ PIC18F2XJ50/PIC18F4XJ50
P12	THLD2	Input Data Hold Time from MCLR ↑	400	—	μs	
P13	TSET2	VDD ↑ Setup Time to MCLR ↑	100	—	ns	
P14	TVALID	Data Out Valid from PGC ↑	25	—	ns	
P16	TDLY8	Delay between Last PGC ↓ and MCLR ↓	20	—	ns	
P17	THLD3	MCLR ↓ to VDD ↓	3	—	μs	
P19	TKEY1	Delay from First MCLR ↓ to First PGC ↑ for Key Sequence on PGD	4	—	ms	
P20	TKEY2	Delay from Last PGC ↓ for Key Sequence on PGD to Second MCLR ↑	50	—	ns	

- Note 1:** External power must be supplied to the VDDCORE/VCAP pin if the on-chip voltage regulator is disabled. See **Section 2.1.1 “PIC18F2XJXX/4XJXX/ LF2XJXX/LF4XJXX Devices and the On-Chip Voltage Regulator”** for more information.
- 2:** VDD must also be supplied to the AVDD pins during programming. AVDD and AVSS should always be within ±0.3V of VDD and VSS, respectively.