

Welcome to E-XFL.COM

Understanding [Embedded - Microcontroller, Microprocessor, FPGA Modules](#)

Embedded - Microcontroller, Microprocessor, and FPGA Modules are fundamental components in modern electronic systems, offering a wide range of functionalities and capabilities. Microcontrollers are compact integrated circuits designed to execute specific control tasks within an embedded system. They typically include a processor, memory, and input/output peripherals on a single chip. Microprocessors, on the other hand, are more powerful processing units used in complex computing tasks, often requiring external memory and peripherals. FPGAs (Field Programmable Gate Arrays) are highly flexible devices that can be configured by the user to perform specific logic functions, making them invaluable in applications requiring customization and adaptability.

Applications of [Embedded - Microcontroller,](#)

Details

Product Status	Obsolete
Module/Board Type	FPGA Core
Core Processor	Kintex-7 325T
Co-Processor	-
Speed	200MHz
Flash Size	32MB
RAM Size	-
Connector Type	Samtec LSHM
Size / Dimension	1.97" x 1.57" (50mm x 40mm)
Operating Temperature	0°C ~ 70°C
Purchase URL	https://www.e-xfl.com/product-detail/trenz-electronic/te0741-03-325-2cf

Table of Contents

Overview	3
Key Features	3
Block Diagram	4
Main Components	5
Initial Delivery State	6
Signals, Interfaces and Pins	7
Board to Board (B2B) I/Os	7
JTAG Interface	7
System Controller I/O Pins	8
On-board LEDs	8
Clocking	9
On-board Peripherals	10
Programmable PLL Clock (Phase-Locked Loop)	10
32 MByte Quad SPI Flash Memory	11
GTX Transceivers	12
System Controller CPLD	13
Power and Power-On Sequence	14
Power Supply	14
Power-On Sequence	14
Power Rails	15
Bank Voltages	15
Board to Board Connectors	16
Connector Mechanical Ratings	16
Manufacturer Documentation	17
Variants Currently In Production	18
Technical Specifications	19
Absolute Maximum Ratings	19
Recommended Operating Conditions	19
Operating Temperature Ranges	19
Physical Dimensions	20
Weight	20
Revision History	21
Hardware Revision History	21
Document Change History	21
Disclaimer	23
Document Warranty	23
Limitation of Liability	23
Copyright Notice	23
Technology Licenses	23
Environmental Protection	23
REACH, RoHS and WEEE	24

Block Diagram

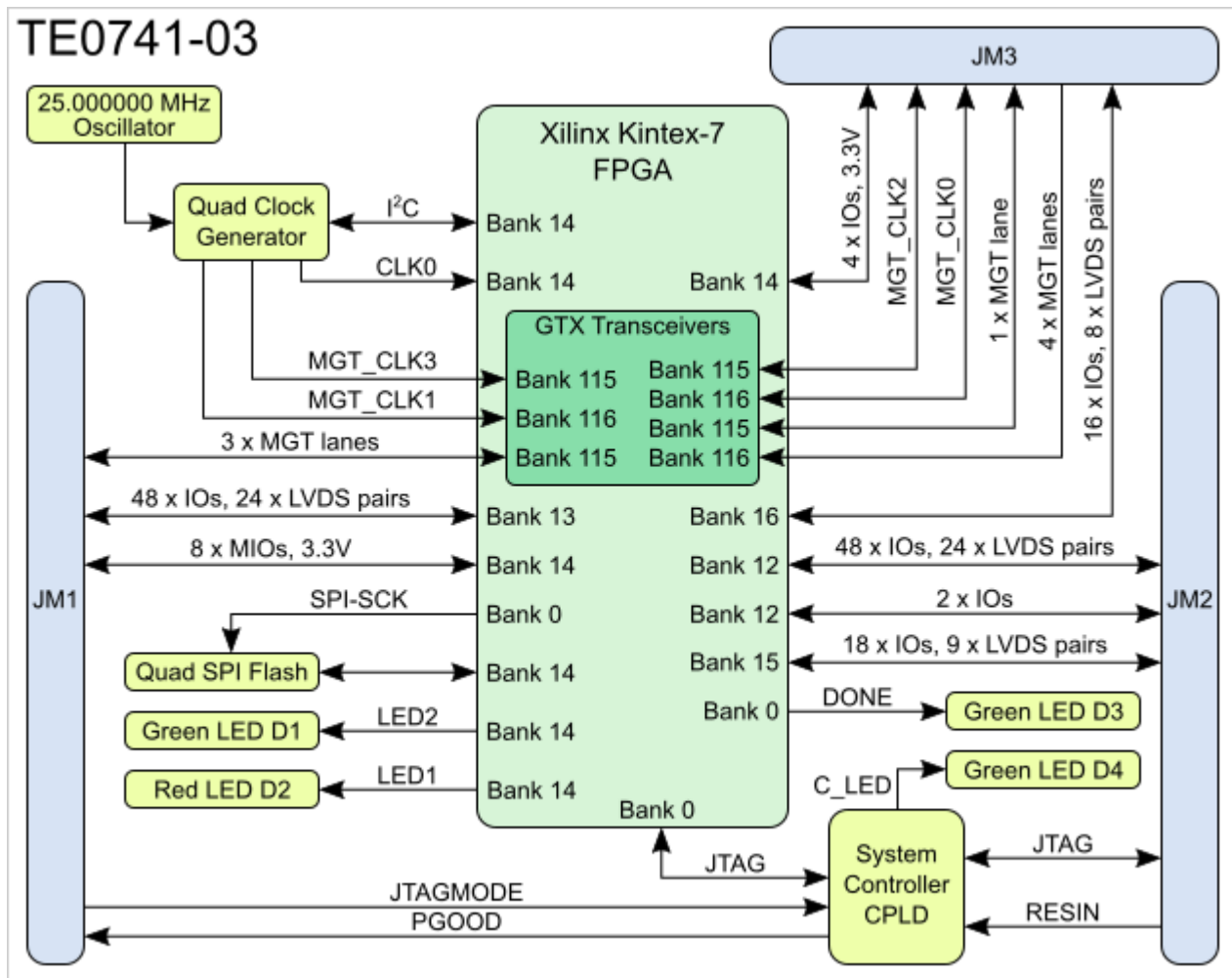

Figure 1: TE0741 block diagram.

Main Components

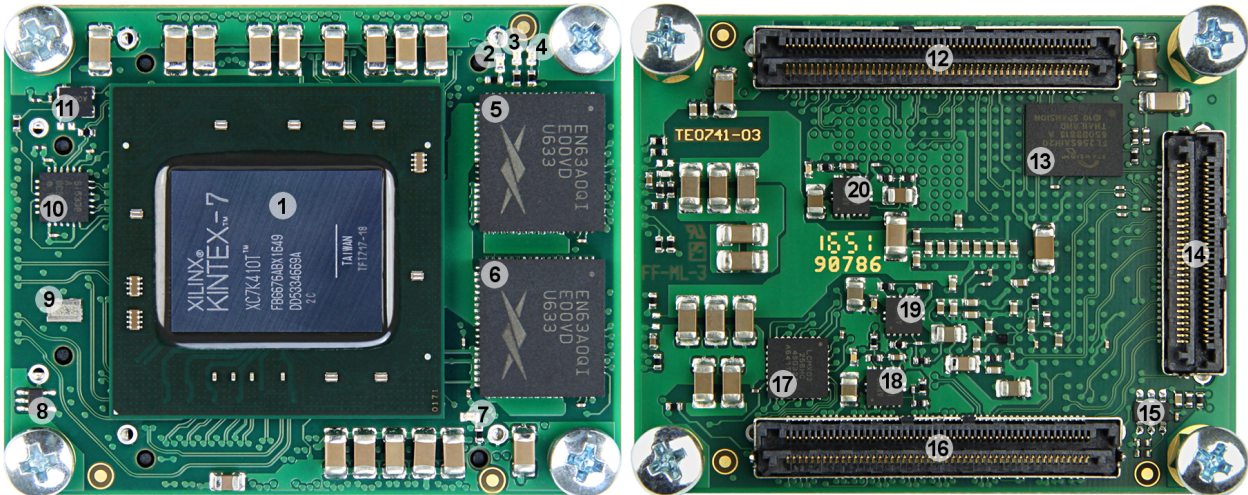

Figure 2.1: TE0741--03-410-2CF module.

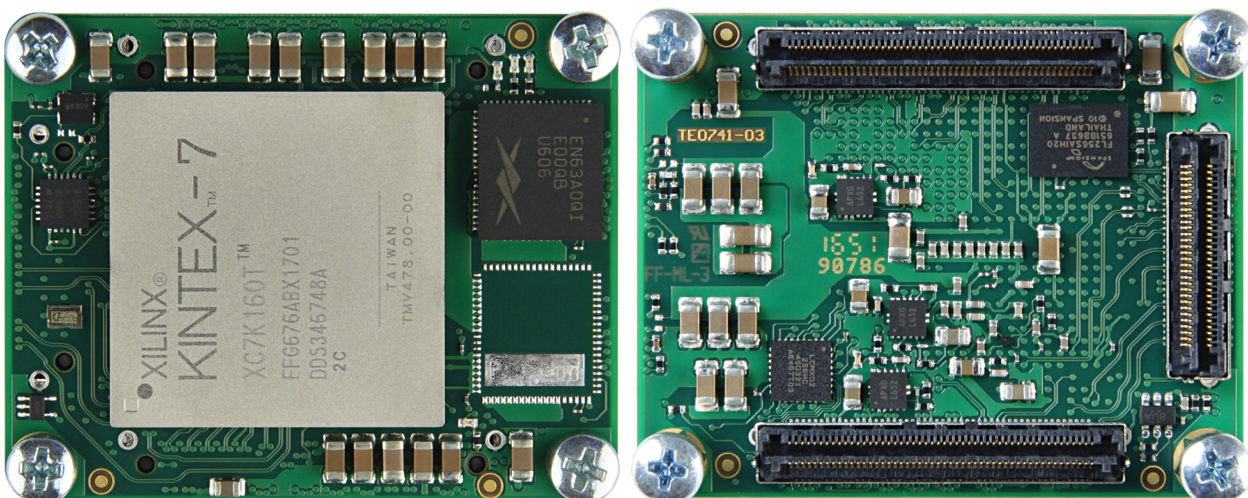

Figure 2.2: TE0741-03-160-2C1 module.

1. Xilinx Kintex-7 FPGA, U1
2. Green LED (DONE), D3
3. Red LED (LED1), D2
4. Green LED (LED2), D1
5. EN63A0QI Voltage Regulator 1.0V (Master), U14
6. EN63A0QI Voltage Regulator 1.0V (Slave), U15
7. Green LED (C_LED), D4
8. Voltage detector, U11
9. Serial number (traceability) pad
10. I²C-programmable any-frequency, any-output quad clock generator, U2
11. Low-power programmable oscillator @ 25.000000 MHz, U3
12. Samtec Razor Beam™ LSHM-150 B2B connector, JM2
13. 32 MByte quad SPI Flash memory, U4

14. Samtec Razor Beam™ LSHM-130 B2B connector, JM3
15. 3A PFET load switch with configurable slew rate (3.3V), Q1
16. Samtec Razor Beam™ LSHM-150 B2B connector, JM1
17. System Controller CPLD, U7
18. EP53F8QI Voltage Regulator (1.2V_MGT), U6
19. EP53F8QI Voltage Regulator (1.8V), U8
20. EP53F8QI Voltage Regulator (1V_MGT), U16

Initial Delivery State

Storage device name	Content	Notes
SPI Flash OTP Area	Empty, not programmed	Except serial number programmed by flash vendor.
SPI Flash Quad Enable bit	Programmed	-
SPI Flash main array	Demo design	-
eFUSE USER	Not programmed	-
eFUSE Security	Not programmed	-

Table 1: Initial delivery state.

Signals, Interfaces and Pins

Board to Board (B2B) I/Os

Overview of the I/O signal banks connected to the B2B connectors:

Bank	Type	B2B Connector	I/O Signal Count	Voltage	Notes
0	HR	-	-	3.3V	Configuration bank.
12	HR	JM2	50 I/Os, 24 LVDS pairs	User	Supported voltage level from 1.2V to 3.3V. NOTE: BANK 12 IS NOT AVAILABLE ON THE K70T DEVICE!
13	HR	JM1	48 I/Os, 24 LVDS pairs	User	Supported voltage level from 1.2V to 3.3V.
14	HR	JM1 JM3	8 I/Os 4 I/Os, 2 LVDS pairs	3.3V	IO pins at B2B connector JM1, support only 3.3 V.
15	HR	JM2	18 I/Os, 9 LVDS pairs	User	Supported voltage level from 1.2V to 3.3V.
16	HR	JM3	16 I/Os, 8 LVDS pairs	User	Supported voltage level from 1.2V to 3.3V.
32	HP	NC	-	-	Bank not used.
33	HP	NC	-	-	Bank not used.
34	HP	NC	-	-	Bank not used.

Table 2: Available I/O signal banks connected to the B2B connectors.

Please use [Master Pin-out Table](#) table as primary reference for the pin mapping information.

JTAG Interface

JTAG access to the Xilinx Kintex-7 and to the System Controller CPLD is provided through B2B connector JM2.

JTAG Signal	B2B Connector
TMS	JM2-93
TDI	JM2-95
TDO	JM2-97
TCK	JM2-99

Table 3: Pin-mapping of JTAG Interface on B2B connector.

⚠ JTAGMODE pin 89 in B2B connector JM1 is used to select which device is accessible, low - Xilinx Kintex-7, high - System Controller CPLD.

System Controller I/O Pins

Special purpose pins are connected to smaller System Controller CPLD and have following default configuration:

Pin Name	Mode	Function	Default Configuration	B2B Connector
PGOOD	Output	Power Good	Active high when all on-module power supplies are working properly.	JM1-30
RESIN	Input	Reset	Active low reset signal, drive low to keep the system in reset (FPGA pin PROG_B will be driven by CPLD).	JM2-18
JTAGMODE	Input	JTAG Select	Low for normal operation, high (3.3V) to program the System Controller CPLD.	JM1-89

Table 4: Pin-description of System Controller CPLD.

On-board LEDs

There are four LED's available on TE0741 SoM. Two status LED's (D3 and D4) and two user configurable LED's (D1 and D2).

LED	Color	Connected to	Description and Notes
D1	Green	LED2	User configurable LED.
D2	Red	LED1	User configurable LED.
D3	Green	DONE	Reflects inverted DONE signal, ON when FPGA is not configured, OFF as soon as PL is configured. This LED will not operate if the the 3.3V power rail is not available. After FPGA configuration the user can use USRACCESSE2 to control Done LED.
D4	Green	C_LED	Connected to the system controller indicating status of the module: Steadily lit: RESIN pin is kept low. Blinking fast (0.1s on/off): Power sequencing fault (PG_ALL = 0). Blinking at medium speed (0.5s on/off): Power sequencing has completed but the FPGA is not configured (PG_ALL = 1, DONE = 0). Blinking slow (1s on/off): FPGA is configured and board is ready (PG_ALL = 1, DONE = 1). It is also possible to program the System Controller CPLD to connect this LED to FPGA pin named XIO.

Table 5: Description of the on board LED's.

Note: if FPGA logic toggles DONE pin (to control D3) then D4 will toggle at random, as changing value on DONE will change the blink frequency of D4.

 DONE LED will be ON as long as FPGA is NOT configured and will be OFF when FPGA is configured successfully. If user STARTUPE2 primitive is used in user design then DONE LED is controlled by the user design and can be on/off/blink or have any other functionality defined by the user.

Clocking

To enable the PLL (phase-locked loop) clock generator Si5338A (U2), CLK_EN-signal (bank 14, pin C26) must be set to high, to activate the 25 MHz reference clock SiT8208AI (U3). The GTX reference clocks 0 and 2 have to be provided by the user on B2B connector JM3.

Clock	Frequency	IC	FPGA	Notes
PLL reference	25 MHz	U3 SiT8208AI	-	Activated by CLK_EN pin of FPGA.
GTX REFCLK0	-	B2B	D5/D6	B2B connector pins: MGT_CLK_0_N: JM3-31 MGT_CLK_0_P: JM3-33 Needs decoupling and differential terminator on base board.
GTX REFCLK1	125 MHz	U2 Si5338	F5/F6	PLL clock 1, default frequency is 125 MHz.
GTX REFCLK2	-	B2B	H5/H6	B2B connector pins: MGT_CLK_2_N: JM3-32 MGT_CLK_2_P: JM3-34 Needs decoupling and differential terminator on base board.
GTX REFCLK3	125 MHz	U2 Si5338	K5/K6	PLL clock 2, default not configured
Bank 14 input clock	100 MHz	U2 Si5338	F22/E23	PLL clock 0, default frequency is 100 MHz.

Table 6: Clocks overview.

On-board Peripherals

Programmable PLL Clock (Phase-Locked Loop)

There is a Silicon Labs I2C programmable clock generator Si5338A (U2) chip on the module. Its output frequencies can be programmed using the I2C bus address 0x70 or 0x71 (PLL_IN4 (LSB of I2C-Address) must be set for address 0x71).

A 25 MHz oscillator is connected to pin IN3 and is used to generate the output clocks. The oscillator has its enable pin connected to an FPGA pin (CLK_EN). Driving the FPGA pin low will disable the oscillator output, setting it high will enable it. Three of the Si5338 clock outputs are connected to the FPGA. One is connected to a logic bank and the other two are connected to the GTX banks. It is possible to use the clocks connected to the GTX bank in the user's logic design. This is achieved by instantiating a IBUFDSGTE buffer in the design.

The default frequency of each clock at start up is detailed in the table 7.

Once running, the frequency and other parameters can be changed by programming the device using the I2C bus connected between the FPGA (master) and clock generator (slave). Logic needs to be generated inside the FPGA to utilize I2C bus correctly.

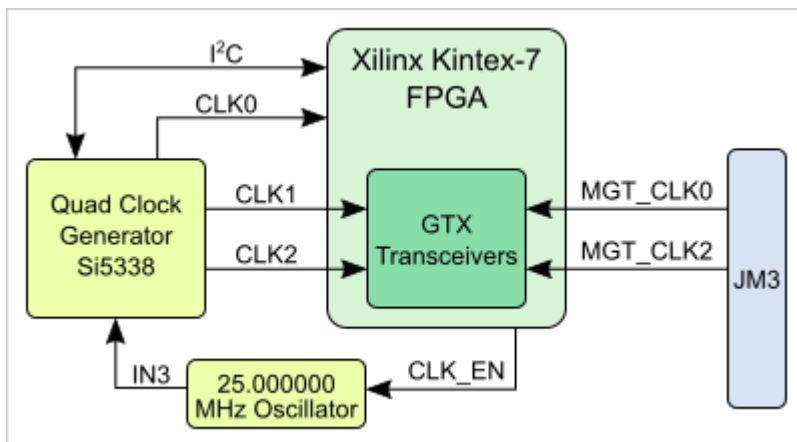

Figure 3: Clocking block diagram.

I/O Si5338A (U2)	Default Frequency	Notes
IN1/IN2	-	Not used (external clock signal supply).
IN3	25MHz	Fixed input clock signal from. reference clock generator SIT8208AI (U3).
IN4	-	LSB of the default I2C-Adress 0x70.
IN5/IN6	-	Not used (external clock signal supply).
CLK0 A/B	100 MHz	Bank 14 clock input, Pins: B14_L12_P, B14_L12_N

I/O Si5338A (U2)	Default Frequency	Notes
CLK1 A/B	125MHz	MGT reference clock 1 to FPGA Bank 116 MGT
CLK2 A/B	-	MGT reference clock 3 to FPGA Bank 115 MGT
CLK3	-	not used

Table 7: Pin description of Si5338A PLL clock generator.

32 MByte Quad SPI Flash Memory

An SPI flash memory S25FL256SAGBHI20 (U4) is provided for FPGA configuration file storage. After configuration completes the remaining free memory can be used for application data storage. All four SPI data lines are connected to the FPGA allowing x1, x2 or x4 data bus widths to be used. The maximum data transfer rate depends on the bus width and clock frequency.



SPI Flash QE (Quad Enable) bit must be set, or the FPGA would not configure itself from Flash. This bit is always set at the manufacturing.

GTX Transceivers

The Kintex-7 device that is used on the TE0741 board has 8 GTX transceivers. All 8 are wired directly to connectors JM1 and JM3. There are also 4 clocks that are associated with the transceivers. Two of the clocks are connected directly to JM3, whilst the other two are derived from the clock generator. As there is no capacitive coupling of the data and clock lines that are connected to the connectors, these may be required on the user's PCB depending on the application.

To enable the voltage supply for the GTX transceivers, namely the Enpirion EP53F8QI voltage regulators U6 and U16, which serve the voltages MGTAVCC (1.0 V) and MGTAVTT (1.2 V), the signal EN_MGT (bank 14, pin H22) have to be set high. The voltage regulators will indicate "Power OK" with signals PG_MGT_1V and PG_MGT_1V2, when reaching stable state.

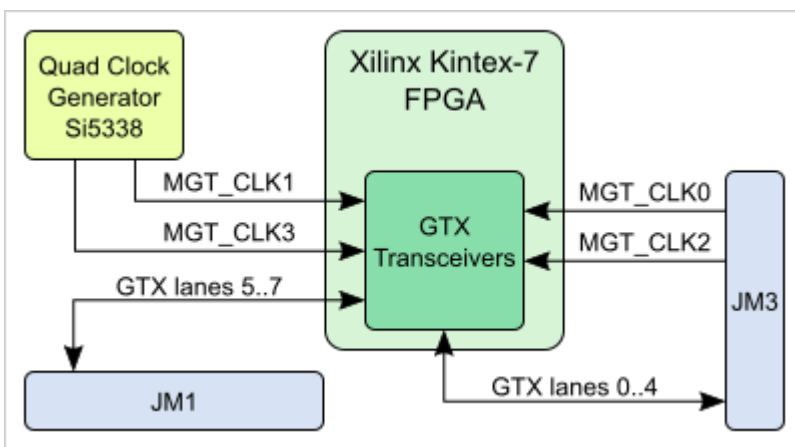

Figure 4: GTX transceiver block diagram.

System Controller CPLD

The System Controller CPLD is used to coordinate the configuration of the FPGA. The FPGA is held in reset (by driving the PROG_B signal) until the power supplies have sequenced. Setting input signal RESIN low will also reset the FPGA. This signal can be driven from the user's PCB via the board connector.

User can create its own System Controller CPLD design using the Lattice Diamond software and program it into the device using the JTAG interface. The JTAGMODE signal should be set to 3.3V to enable programming mode, for normal module operation it should be set to 0V.

Green LED D4 (C_LED) connected to the System Controller CPLD is to indicate the status of the module.

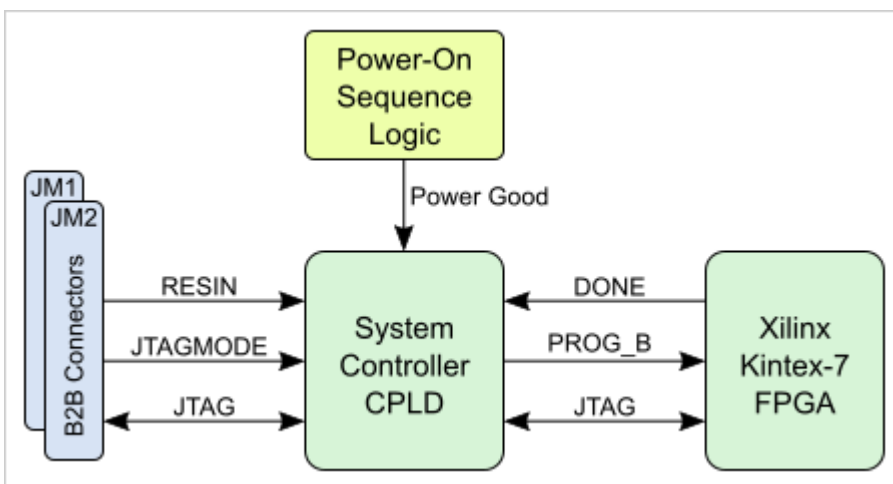

Figure 5: System Controller CPLD block diagram.

Power and Power-On Sequence

Power Supply

Power supply with minimum current capability of 3A for system startup is recommended.

Power Consumption

Power Input Pin	Typical Current
VIN	TBD*
3.3VIN	TBD*

Table 8: Maximum current of power supplies.

* TBD - To Be Determined.

Lowest power consumption is achieved when powering the module from single 3.3V supply. When using split 3.3V/5V power supplies, the power consumption (and heat dissipation) will rise, this is due to the DC-DC converter efficiency (it decreases when VIN/VOUT ratio rises).

Power-On Sequence

For highest efficiency of on board DC-DC regulators, it is recommended to use same 3.3V power source for both VIN and 3.3VIN power rails. Although VIN and 3.3VIN can be powered up in any order, it is recommended to power them up simultaneously.

It is important that all baseboard I/Os are 3-stated at power-on until System Controller sets PGOOD signal high (B2B connector JM1, pin 30), or 3.3V is present on B2B connector JM2 pins 10,12 or 91, meaning that all on-module voltages have become stable and module is properly powered up.

See Xilinx datasheet [DS182](#) for additional information. User should also check related baseboard documentation when choosing baseboard design for TE0741 module.

The FPGA 1.0V supply is derived from two regulators operating in a parallel allowing higher load currents. To start the power-on sequence, pin EN1 (JM1-28, enable 1.0V voltage regulators) is by default high. By driving EN1 pin low on base-board the power-on sequence will not start until the EN1 pin is released to high.

Power Rails

Voltages on B2B-Connectors	B2B JM1 Pin	B2B JM2 Pin	B2B Direction	Note
VIN	1, 3, 5	2, 4, 6, 8	Input	Supply voltage.
3.3VIN	13, 15	-	Input	Supply voltage.
VCCIO12	-	7, 9	Input	High range bank voltage.
VCCIO13	9, 11	-	Input	High range bank voltage.
VCCIO15	-	5	Input	High range bank voltage.
VCCIO16	-	1, 3	Input	High range bank voltage.
3.3V	-	10, 12, 91	Output	Internal 3.3V voltage level.

Table 9: Power rails of SoM on B2B connectors.

Bank Voltages

Bank	Schematic Name	Voltage	Range
0 Config	3.3V	3.3V	-
12	VCCIO12	user	HR: 1.2V to 3.3V
13	VCCIO13	user	HR: 1.2V to 3.3V
14	3.3V	3.3V	-
15	VCCIO15	user	HR: 1.2V to 3.3V
16	VCCIO16	user	HR: 1.2V to 3.3V

Table 10: Range of FPGAs bank voltages.

See Xilinx Kintex-7 datasheet [DS182](#) for the voltage ranges allowed.

Board to Board Connectors

- ⊖ These connectors are hermaphroditic. Odd pin numbers on the module are connected to even pin numbers on the baseboard and vice versa.

Trenz Electronic 4 x 5 modules use two or three Samtec Razor Beam™ LSHM connectors on the bottom side.

- 2 x REF-189016-02 (compatible to LSHM-150-04.0-L-DV-A-S-K-TR), (100 pins, "50" per row)
- 1 x REF-189017-02 (compatible to LSHM-130-04.0-L-DV-A-S-K-TR), (60 pins, "30" per row) (depending on module)

When using the same type on baseboard, the mating height is 8mm. Other mating heights are possible by using connectors with a different height:

Connector on baseboard	compatible to	Mating height
REF-189016-01	LSHM-150-02.5-L-DV-A-S-K-TR	6.5 mm
LSHM-150-03.0-L-DV-A-S-K-TR	LSHM-150-03.0-L-DV-A-S-K-TR	7.0 mm
REF-189016-02	LSHM-150-04.0-L-DV-A-S-K-TR	8.0 mm
LSHM-150-06.0-L-DV-A-S-K-TR	LSHM-150-06.0-L-DV-A-S-K-TR	10.0mm
REF-189017-01	LSHM-130-02.5-L-DV-A-S-K-TR	6.5 mm
LSHM-130-03.0-L-DV-A-S-K-TR	LSHM-130-03.0-L-DV-A-S-K-TR	7.0 mm
REF-189017-02	LSHM-130-04.0-L-DV-A-S-K-TR	8.0 mm
LSHM-130-06.0-L-DV-A-S-K-TR	LSHM-130-06.0-L-DV-A-S-K-TR	10.0mm

The module can be manufactured using other connectors upon request.

The LSHM connector speed rating depends on the stacking height, please see the following table:

Stacking height	Speed rating
12 mm, Single-ended	7.5 GHz / 15 Gbps
12 mm, Differential	6.5 GHz / 13 Gbps
5 mm, Single-ended	11.5 GHz / 23 Gbps
5 mm, Differential	7.9 GHz / 14 Gbps

Connector Mechanical Ratings

- Shock: 100G, 6 ms sine
- Vibration: 7.5G random, 3 hours 3 axis

Manufacturer Documentation

Name	Version	Date
LSHM-1XX-XX.X-X-DV-A-X-X-TR-FOOTPRINT(1).pdf	1	2013-11-28 16:54
LSHM-1XX-XX.X-XX-DV-A-X-X-TR-MKT.pdf	1	2013-11-28 16:56
REF-189016-01.pdf	1	2015-10-30 11:54
REF-189016-02.pdf	1	2015-10-30 11:54
REF-189017-01.pdf	1	2015-10-30 11:54
REF-189017-02.pdf	1	2015-10-30 11:54
TC0923--2523_report_Rev_2_qua.pdf	1	2013-11-28 16:55
hsc-report_lshm-lshm-05mm_web.pdf	1	2013-11-28 16:56
lshm_dv.pdf	1	2013-11-28 16:56
tc0929--2611_qua(1).pdf	1	2013-11-28 16:55

Variants Currently In Production

Module Variant	FPGA	U15	FPGA Junction Temperature	Temperature Grade
TE0741-03-070-2CF	XC7K70T-2FBG676C	-	0°C to 85°C	Commercial grade
TE0741-03-070-2IF	XC7K70T-2FBG676I	-	-40°C to 100°C	Industrial grade
TE0741-03-160-2CF	XC7K160T-2FBG676C	-	0°C to 85°C	Commercial grade
TE0741-03-160-2C1	XC7K160T-2FFG676C	-	0°C to 85°C	Commercial grade
TE0741-03-160-2IF	XC7K160T-2FBG676I	-	-40°C to 100°C	Industrial grade
TE0741-03-325-2CF	XC7K325T-2FBG676C	EN63A0QI	0°C to 85°C	Commercial grade
TE0741-03-325-2IF	XC7K325T-2FBG676I	EN63A0QI	-40°C to 100°C	Industrial grade
TE0741-03-410-2CF	XC7K325T-2FBG676C	EN63A0QI	0°C to 85°C	Commercial grade

Table 11: Module TE0741-03 variants.

Technical Specifications

Absolute Maximum Ratings

Parameter	Min	Max	Units	Notes
VIN supply voltage	-0.3	6.5	V	-
3.3VIN supply voltage	-0.1	3.6	V	-
PL I/O bank supply voltage for HR I/O banks (VCCO)	-0.5	3.6	V	-
I/O input voltage for HR I/O banks	-0.4	VCCO_X+0.55	V	-
GT receiver (RXP/RXN) and transmitter (TXP/TXN)	-0.5	1.26	V	Xilinx datasheet DS182
Voltage on module JTAG pins	-0.5	VCCO_0+0.45	V	VCCO_0 is 3.3V nominal.
Storage temperature	-55	+125	°C	-

Table 12: Absolute maximum ratings.

Recommended Operating Conditions

Parameter	Min	Max	Units	Notes	Reference Document
VIN supply voltage	2.4	5.5	V	-	EP53F8QI data sheet
3.3VIN supply voltage	3.135	3.465	V	3,3V ± 5%	-
PL I/O bank supply voltage for HR I/O banks (VCCO)	1.14	3.465	V	-	Xilinx datasheet DS182
I/O input voltage for HR I/O banks	-0.20	VCCO+0.2	V	-	Xilinx datasheet DS182
GT receiver (RXP/RXN) and transmitter (TXP/TXN)	(*)	(*)	-	-	* See datasheet DS182
Voltage on module JTAG pins	3.135	3.465	V	-	-

Table 13: Recommended operation conditions.

Operating Temperature Ranges

Commercial grade: 0°C to +70°C.

Industrial grade: -40°C to +85°C.

The module operating temperature range depends also on customer design and cooling solution. Please contact us for options.



Check Xilinx datasheet [DS182](#) for complete list of absolute maximum and recommended operating ratings.

Revision History

Hardware Revision History

Date	Revision	Notes	PCN	Documentation
2016-10-25	03	1) Fixed DC-DC connection for parallel operation 2) Samtec Razor Beam connectors updated 3) Serial number (traceability) pad added 4) Changed ferrite beads L1..L4 size 0402 to BKP0603HS121-T 5) Thermal vias added to mounting holes	PCN-20170106	TE0741-03
2013-11-06	02	<ul style="list-style-type: none"> Improved power-on-sequencing Added differential terminator to bank 14 clock input 		TE0741-02
	01	First production release		

Hardware revision number is written on the PCB board together with the module model number separated by the dash.

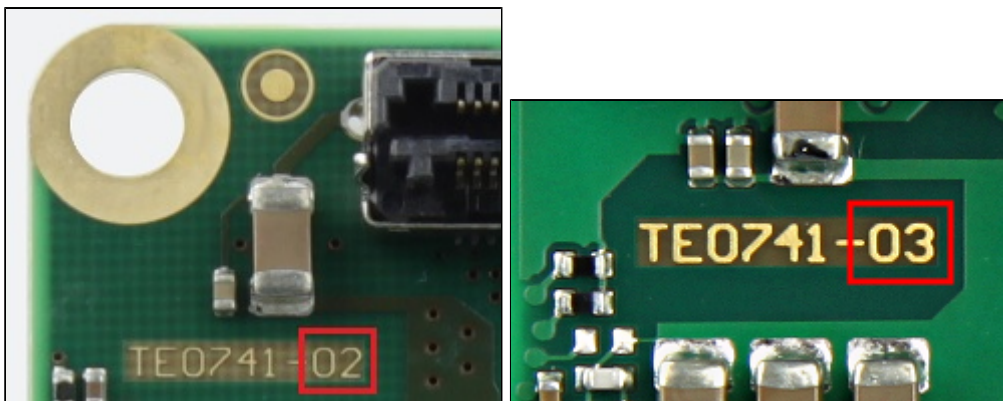

Figure 7: TE0741 PCB revision number.

Document Change History

Date	Revision	Contributors	Description
2017-08-29	V.60	Jan Kumann	New power-on diagram. Few improvements. Template revision added.
2017-07-20	v.57	John Hartfiel	Correction: PLL default output CLKs.
2017-06-07	v.55	Jan Kumann	Minor formatting
2017-06-02	v.50	Jan Kumann	REV03 specific update.
2017-01-22	v.42	Jan Kumann	New block diagram added.

Date	Revision	Contributors	Description
2017-01-13	v.38	Jan Kumann	New product images and physical dimension drawings. Formatting improvements and small corrections.
2017-01-12	v.21	John Hartfiel	Correction: B2B and FPGA bank location.
2016-12-14	v.19	Ali Naseri	TRM revision.
2013-12-02	v.1	Antti Lukats, Jon Bean	Initial version.

REACH, RoHS and WEEE

REACH

Trenz Electronic is a manufacturer and a distributor of electronic products. It is therefore a so called downstream user in the sense of [REACH](#). The products we supply to you are solely non-chemical products (goods). Moreover and under normal and reasonably foreseeable circumstances of application, the goods supplied to you shall not release any substance. For that, Trenz Electronic is obliged to neither register nor to provide safety data sheet. According to present knowledge and to best of our knowledge, no [SVHC \(Substances of Very High Concern\) on the Candidate List](#) are contained in our products. Furthermore, we will immediately and unsolicited inform our customers in compliance with REACH - Article 33 if any substance present in our goods (above a concentration of 0,1 % weight by weight) will be classified as SVHC by the [European Chemicals Agency \(ECHA\)](#).

RoHS

Trenz Electronic GmbH herewith declares that all its products are developed, manufactured and distributed RoHS compliant.

WEEE

Information for users within the European Union in accordance with Directive 2002/96/EC of the European Parliament and of the Council of 27 January 2003 on waste electrical and electronic equipment (WEEE).

Users of electrical and electronic equipment in private households are required not to dispose of waste electrical and electronic equipment as unsorted municipal waste and to collect such waste electrical and electronic equipment separately. By the 13 August 2005, Member States shall have ensured that systems are set up allowing final holders and distributors to return waste electrical and electronic equipment at least free of charge. Member States shall ensure the availability and accessibility of the necessary collection facilities. Separate collection is the precondition to ensure specific treatment and recycling of waste electrical and electronic equipment and is necessary to achieve the chosen level of protection of human health and the environment in the European Union. Consumers have to actively contribute to the success of such collection and the return of waste electrical and electronic equipment. Presence of hazardous substances in electrical and electronic equipment results in potential effects on the environment and human health. The symbol consisting of the crossed-out wheeled bin indicates separate collection for waste electrical and electronic equipment.

Trenz Electronic is registered under WEEE-Reg.-Nr. DE97922676.