



Welcome to E-XFL.COM

Understanding [Embedded - Microcontroller, Microprocessor, FPGA Modules](#)

Embedded - Microcontroller, Microprocessor, and FPGA Modules are fundamental components in modern electronic systems, offering a wide range of functionalities and capabilities. Microcontrollers are compact integrated circuits designed to execute specific control tasks within an embedded system. They typically include a processor, memory, and input/output peripherals on a single chip. Microprocessors, on the other hand, are more powerful processing units used in complex computing tasks, often requiring external memory and peripherals. FPGAs (Field Programmable Gate Arrays) are highly flexible devices that can be configured by the user to perform specific logic functions, making them invaluable in applications requiring customization and adaptability.

Applications of [Embedded - Microcontroller,](#)

Details

Product Status	Not For New Designs
Module/Board Type	MPU, DSP Core
Core Processor	ARM® Cortex®-A8, DM3730
Co-Processor	TMS320C64x (DSP)
Speed	800MHz
Flash Size	512MB
RAM Size	512MB
Connector Type	Board-to-Board (BTB) Socket - 200
Size / Dimension	0.59" x 1.06" (15mm x 27mm)
Operating Temperature	-40°C ~ 85°C
Purchase URL	https://www.e-xfl.com/product-detail/logic-pd/somdm3730-20-1880agir

PRODUCT BRIEF:

Logic PD :: Texas Instruments
www.logicpd.com/ti

DM3730 / AM3703 Torpedo™ System on Module

:: SUPPORTED PROCESSORS:

DM3730
AM3703

The Torpedo System on Module (SOM) is an ultra-compact form factor based on Texas Instruments' DaVinci™ DM3730 and Sitara™ AM3703 processors.

The DM3730 Torpedo SOM occupies less than one square inch, but boasts PC-like speeds up to 1 GHz with long battery life. Partnered with such high performance is a startlingly low power consumption of less than 5 mW when in suspend state. This balance of speed and power is accomplished through Logic PD's vast system design experience; understanding the most detailed workings of each component and their interaction with one another creates a product that operates at optimal efficiency.

The DM3730 Torpedo SOM is available in several standard configurations, including TI's Sitara™ AM3703 ARM microprocessor. By remaining footprint compatible with Logic PD's existing OMAP35x Torpedo SOM, the DM3730 Torpedo SOM extends the roadmaps of existing products and provides an upgrade path from today's products to future technologies.

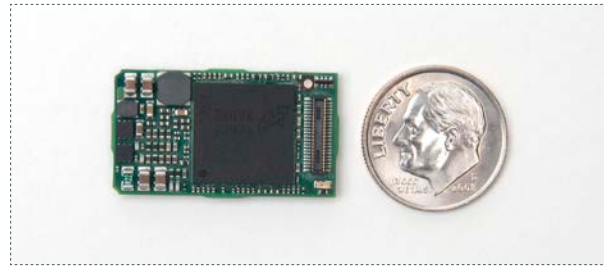

DM3730 / AM3703 TORPEDO SOM

The ultra-compact Torpedo SOM is an ideal off-the-shelf solution for applications in markets where space is a premium. From point-of-care medical devices to hand-held radios to mobile Internet devices, the Torpedo SOM allows for the powerful versatility and compact designs needed in today's market-changing products.

The Zoom™ DM3730 Torpedo Development Kit includes all of the necessary accessories to immediately begin development, helping customers deliver their products to market sooner.

DM3730 / AM3703 TORPEDO SOM :: HIGHLIGHTS:

- +Product-ready System on Module with a TI DM3730 or AM3703 ARM® Cortex™-A8 processor running up to 1 GHz
- +Android, Linux™, and Windows® Embedded CE Board Support Packages (BSPs)
- +Commercial temp (0°C to 70°C)
Industrial temp (-40°C to 85°C)
Extended temp (-40°C to 70°C)
- +Ultra-compact form factor
(15 x 27 x 3.8 mm)
- +Footprint compatible with OMAP35x Torpedo SOM
- +Long product lifecycle

ZOOM™ DM3730 TORPEDO DEVELOPMENT KIT :: FEATURES:

- +Application baseboard
- +DM3730 Torpedo SOM
DM3730 Torpedo + Wireless SOM
- +4.3" WQVGA LCD with 4-wire touchscreen
- +Wattson™ power measurement application
- +Necessary accessories to immediately get up and running
- +See Zoom DM3730 Torpedo Development Kit Product Brief for more information

DM3730 / AM3703 Torpedo™ SOM Block Diagram

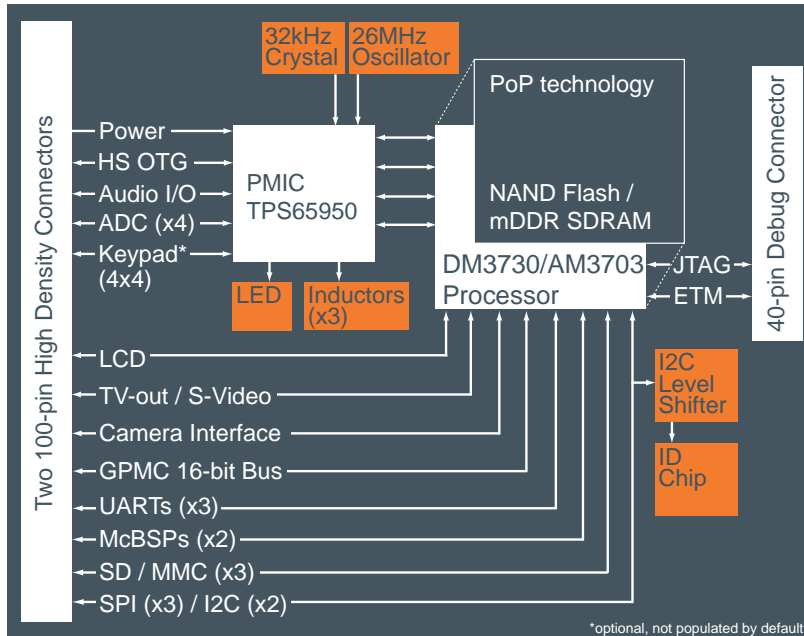

(Block diagram is not drawn to scale. For reference purposes only.)

DM3730 / AM3703 Torpedo SOM Ordering Information

Model Number	Speed (MHz)	SDRAM (MB)	NAND Flash (MB)	Temperature
SOMAM3703-20-1780AGCR	800	256	512	Commercial (0°C–70°C) ²
SOMDM3730-20-2780AGCR	1000	256	512	Commercial (0°C–70°C) ²
SOMDM3730-20-1780AGIR	800	256	512	Industrial (-40°C–85°C) ³
SOMDM3730-20-1880AGIR	800	512	512	Industrial (-40°C–85°C) ³
SOMDM3730-20-2880AGXR	1000	512	512	Extended (-40°C–70°C) ²

NOTES: 1. Custom configurations are available by special order. Please contact Logic PD Sales for details.

2. Junction temperature of the DM3730/AM3703 processor must stay below 90°C.

3. Junction temperature of the DM3730/AM3703 processor must stay below 105°C.

Zoom™ DM3730 Torpedo Development Kit Ordering Information

Model Number	SOM Configuration	Suggested Resale
SDK-DM3730-30-256512R	SOMDM3730-31-2780AKCR SOMDM3730-20-2780AGCR	\$997



411 N. Washington Ave. Suite 400 Minneapolis, MN 55401
 T : 612.672.9495 F : 612.672.9489 I : www.logicpd.com
 © 2014 Logic PD, Inc. All rights reserved. PN: 1018060 Rev D

LOGIC PD WEBSITE :: DESIGN RESOURCES:

+ Logic PD Products : www.logicpd.com/products
 + Logic PD Technical Support : www.logicpd.com/support
 + Logic PD Sales : www.logicpd.com/contact/inquiry

Product Features

Processor

- + TI DaVinci™ DM3730 or Sitara™ AM3703 ARM® Cortex™-A8 core running up to 1 GHz
- + TMS320C64x DSP core running up to 800 MHz (DM3730 only)
- + POWER SGX™ graphics accelerator (DM3730 only)

Memory

- + Mobile DDR / NAND flash (PoP technology)
 256 MB / 512 MB (standard)
 512 MB / 512 MB (standard)

Display

- + Programmable color LCD controller supports up to a 24 bpp TFT interface
- + Hardware supports XGA 1024x768 at 24-bit color
- + TV-out / S-Video interface

Camera

- + Parallel camera interface

Audio

- + I2S compliant audio codec (16-bit stereo DAC, 13-bit ADC)

User Interface

- + Optional 4x4 keypad interface (requires trade-offs with other features)

PC Card Expansion

- + Multiple SD/MMC card support

USB

- + One USB 2.0 high-speed On-the-Go interface

Serial I/O

- + UARTs, SPI, I2C, McBSPs

GPIO

- + Programmable I/O depending on peripheral requirements
- + General purpose memory controller (GPMC) interface

Debug

- + 40-pin debug connector on top side of SOM
- + JTAG & ETM support

Software

- + LogicLoader™ (bootloader/monitor)
- + Android BSP
- + Linux™ BSP
- + Windows® Embedded CE BSP

Mechanical

- + 15 mm wide x 27 mm long x 3.8 mm high

RoHS Compliant

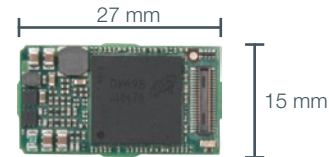

TOP VIEW :: ACTUAL SIZE

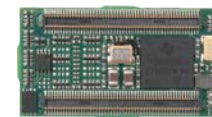

BOTTOM VIEW :: ACTUAL SIZE