



Welcome to [E-XFL.COM](https://www.e-xfl.com)

What is "[Embedded - Microcontrollers](#)"?

"[Embedded - Microcontrollers](#)" refer to small, integrated circuits designed to perform specific tasks within larger systems. These microcontrollers are essentially compact computers on a single chip, containing a processor core, memory, and programmable input/output peripherals. They are called "embedded" because they are embedded within electronic devices to control various functions, rather than serving as standalone computers. Microcontrollers are crucial in modern electronics, providing the intelligence and control needed for a wide range of applications.

Applications of "[Embedded - Microcontrollers](#)"

Details

Product Status	Active
Core Processor	ARM® Cortex®-M0+
Core Size	32-Bit Single-Core
Speed	40MHz
Connectivity	I ² C, LINbus, SPI, UART/USART
Peripherals	LVD, POR, PWM, WDT
Number of I/O	57
Program Memory Size	16KB (16K x 8)
Program Memory Type	FLASH
EEPROM Size	256 x 8
RAM Size	2K x 8
Voltage - Supply (Vcc/Vdd)	2.7V ~ 5.5V
Data Converters	A/D 16x12b
Oscillator Type	Internal
Operating Temperature	-40°C ~ 85°C (TA)
Mounting Type	Surface Mount
Package / Case	64-LQFP
Supplier Device Package	64-LQFP (10x10)
Purchase URL	https://www.e-xfl.com/product-detail/nxp-semiconductors/s9keazn16aclh

-
- Package options
 - 64-pin LQFP
 - 32-pin LQFP

1 Ordering parts

1.1 Determining valid orderable parts

Valid orderable part numbers are provided on the web. To determine the orderable part numbers for this device, go to nxp.com and perform a part number search for the following device numbers: KEAZN64.

2 Part identification

2.1 Description

Part numbers for the chip have fields that identify the specific part. You can use the values of these fields to determine the specific part you have received.

2.2 Format

Part numbers for this device have the following format:

Q B KEA A C FFF M T PP N

2.3 Fields

This table lists the possible values for each field in the part number (not all combinations are valid):

Field	Description	Values
Q	Qualification status	<ul style="list-style-type: none"> S = Automotive qualified P = Prequalification
B	Memory type	<ul style="list-style-type: none"> 9 = Flash
KEA	Kinetis Auto family	<ul style="list-style-type: none"> KEA
A	Key attribute	<ul style="list-style-type: none"> Z = M0+ core F = M4 W/ DSP & FPU C = M4 W/ AP + FPU
C	CAN availability	<ul style="list-style-type: none"> N = CAN not available (Blank) = CAN available

Table continues on the next page...

Field	Description	Values
FFF	Program flash memory size	<ul style="list-style-type: none"> • 16 = 16 KB • 32 = 32 KB • 64 = 64 KB
M	Maskset revision	<ul style="list-style-type: none"> • A = 1st Fab version • B = Revision after 1st version
T	Temperature range (°C)	<ul style="list-style-type: none"> • C = -40 to 85 • V = -40 to 105 • M = -40 to 125
PP	Package identifier	<ul style="list-style-type: none"> • LC = 32 LQFP (7 mm x 7 mm) • LH = 64 LQFP (10 mm x 10 mm)
N	Packaging type	<ul style="list-style-type: none"> • R = Tape and reel • (Blank) = Trays

2.4 Example

This is an example part number:

S9KEAZN64AMLH

3 Ratings

3.1 Thermal handling ratings

Symbol	Description	Min.	Max.	Unit	Notes
T _{STG}	Storage temperature	-55	150	°C	1
T _{SDR}	Solder temperature, lead-free	—	260	°C	2

1. Determined according to JEDEC Standard JESD22-A103, *High Temperature Storage Life*.
2. Determined according to IPC/JEDEC Standard J-STD-020, *Moisture/Reflow Sensitivity Classification for Nonhermetic Solid State Surface Mount Devices*.

3.2 Moisture handling ratings

Symbol	Description	Min.	Max.	Unit	Notes
MSL	Moisture sensitivity level	—	3	—	1

1. Determined according to IPC/JEDEC Standard J-STD-020, *Moisture/Reflow Sensitivity Classification for Nonhermetic Solid State Surface Mount Devices*.

Table 2. DC characteristics (continued)

Symbol	Descriptions			Min	Typical ¹	Max	Unit
I_{INTOT}	Total leakage combined for all port pins	Pins in high impedance input mode	$V_{IN} = V_{DD}$ or V_{SS}	—	—	2	μA
R_{PU}	Pullup resistors	All digital inputs, when enabled (all I/O pins other than PTA2 and PTA3)	—	30.0	—	50.0	k Ω
R_{PU}^3	Pullup resistors	PTA2 and PTA3 pins	—	30.0	—	60.0	k Ω
I_{IC}	DC injection current ^{4, 5, 6}	Single pin limit	$V_{IN} < V_{SS}, V_{IN} > V_{DD}$	-2	—	2	mA
		Total MCU limit, includes sum of all stressed pins		-5	—	25	
C_{in}	Input capacitance, all pins		—	—	—	7	pF
V_{RAM}	RAM retention voltage		—	2.0	—	—	V

1. Typical values are measured at 25 °C. Characterized, not tested.
2. Only PTB4, PTB5, PTD0, PTD1, PTE0, PTE1, PTH0, and PTH1 support high current output.
3. The specified resistor value is the actual value internal to the device. The pullup value may appear higher when measured externally on the pin.
4. All functional non-supply pins, except for PTA2 and PTA3, are internally clamped to V_{SS} and V_{DD} . PTA2 and PTA3 are true open drain I/O pins that are internally clamped to V_{SS} .
5. Input must be current limited to the value specified. To determine the value of the required current-limiting resistor, calculate resistance values for positive and negative clamp voltages, then use the larger value.
6. Power supply must maintain regulation within operating V_{DD} range during instantaneous and operating maximum current conditions. If the positive injection current ($V_{in} > V_{DD}$) is higher than I_{DD} , the injection current may flow out of V_{DD} and could result in external power supply going out of regulation. Ensure that external V_{DD} load will shunt current higher than maximum injection current when the MCU is not consuming power, such as when no system clock is present, or clock rate is very low (which would reduce overall power consumption).

Table 3. LVD and POR specification

Symbol	Description		Min	Typ	Max	Unit
V_{POR}	POR re-arm voltage ¹		1.5	1.75	2.0	V
V_{LVDH}	Falling low-voltage detect threshold—high range (LVDV = 1) ²		4.2	4.3	4.4	V
V_{LVW1H}	Falling low-voltage warning threshold— high range	Level 1 falling (LVWV = 00)	4.3	4.4	4.5	V
V_{LVW2H}		Level 2 falling (LVWV = 01)	4.5	4.5	4.6	V
V_{LVW3H}		Level 3 falling (LVWV = 10)	4.6	4.6	4.7	V
V_{LVW4H}		Level 4 falling (LVWV = 11)	4.7	4.7	4.8	V
V_{HYSH}	High range low-voltage detect/ warning hysteresis		—	100	—	mV

Table continues on the next page...

Table 3. LVD and POR specification (continued)

Symbol	Description	Min	Typ	Max	Unit	
V _{LVDL}	Falling low-voltage detect threshold—low range (LVDV = 0)	2.56	2.61	2.66	V	
V _{LVW1L}	Falling low-voltage warning threshold—low range	Level 1 falling (LVWV = 00)	2.62	2.7	2.78	V
V _{LVW2L}		Level 2 falling (LVWV = 01)	2.72	2.8	2.88	V
V _{LVW3L}		Level 3 falling (LVWV = 10)	2.82	2.9	2.98	V
V _{LVW4L}		Level 4 falling (LVWV = 11)	2.92	3.0	3.08	V
V _{HYS DL}	Low range low-voltage detect hysteresis	—	40	—	mV	
V _{HYS WL}	Low range low-voltage warning hysteresis	—	80	—	mV	
V _{BG}	Buffered bandgap output ³	1.14	1.16	1.18	V	

1. Maximum is highest voltage that POR is guaranteed.
2. Rising thresholds are falling threshold + hysteresis.
3. voltage Factory trimmed at V_{DD} = 5.0 V, Temp = 125 °C

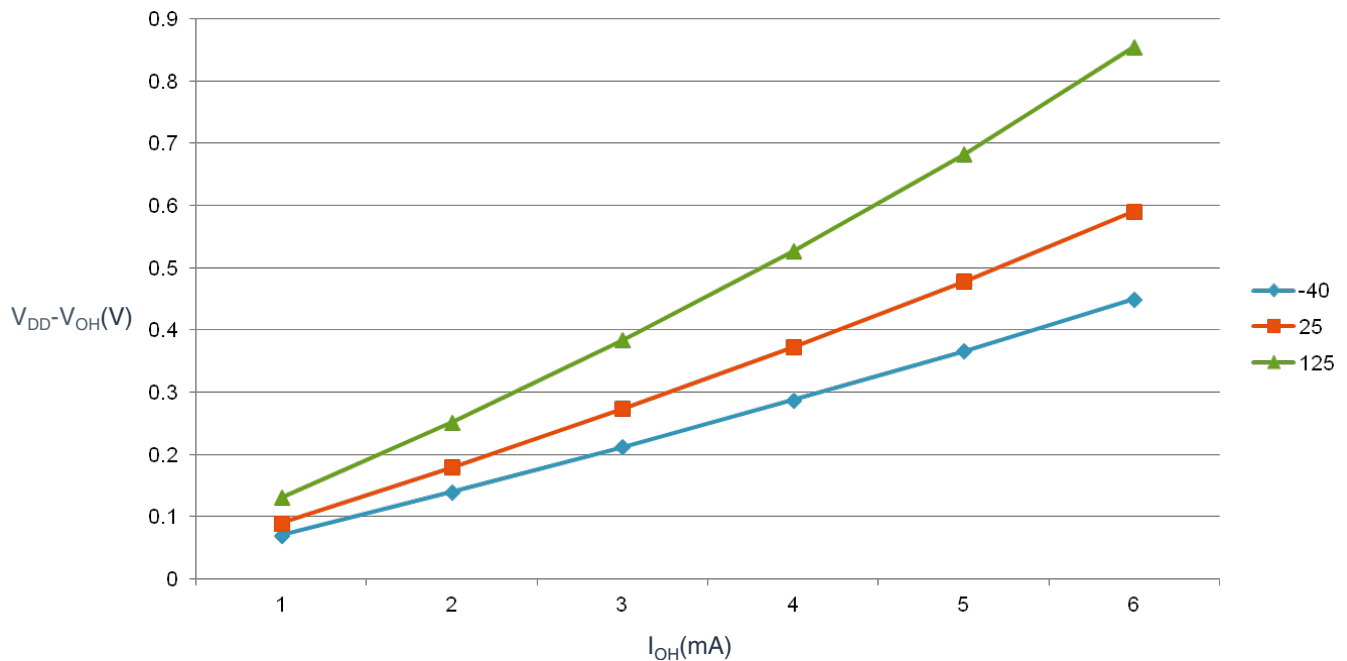

Figure 1. Typical V_{DD}-V_{OH} Vs. I_{OH} (standard drive strength) (V_{DD} = 5 V)

Nonswitching electrical specifications

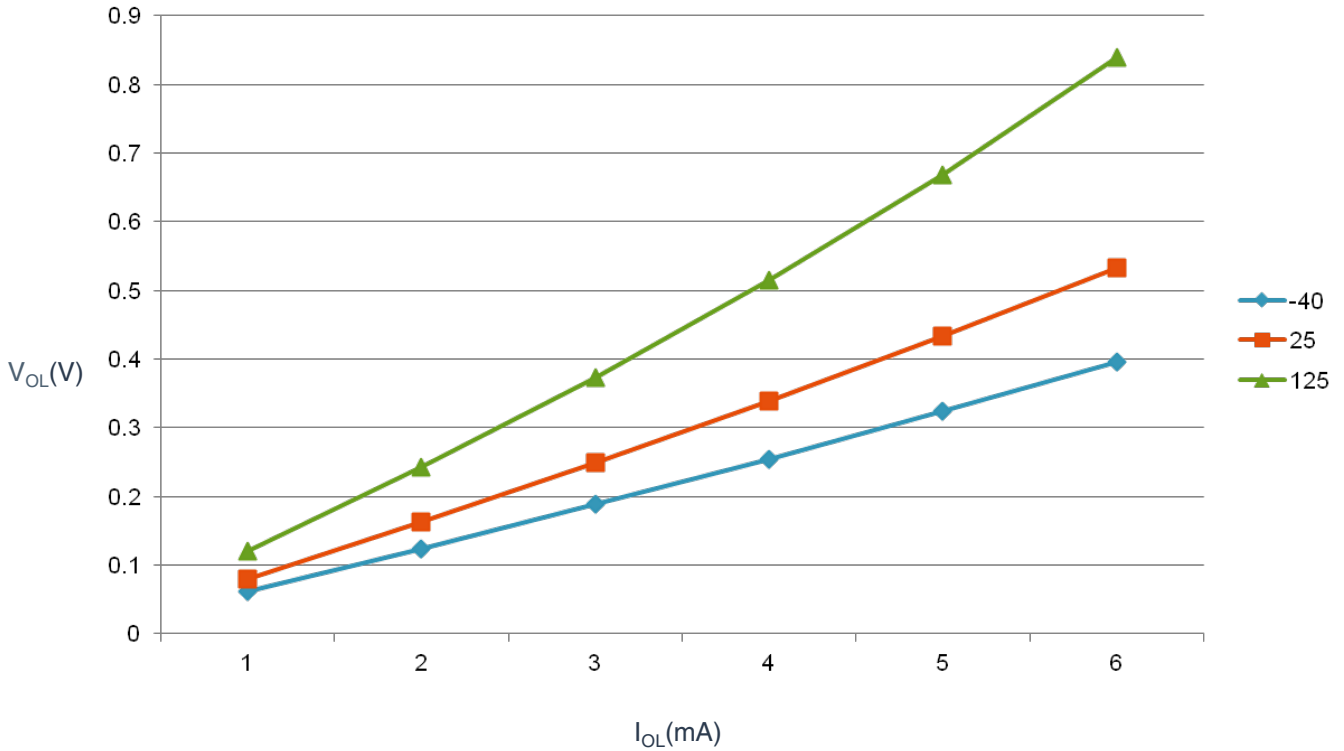

Figure 6. Typical V_{OL} Vs. I_{OL} (standard drive strength) ($V_{DD} = 3$ V)

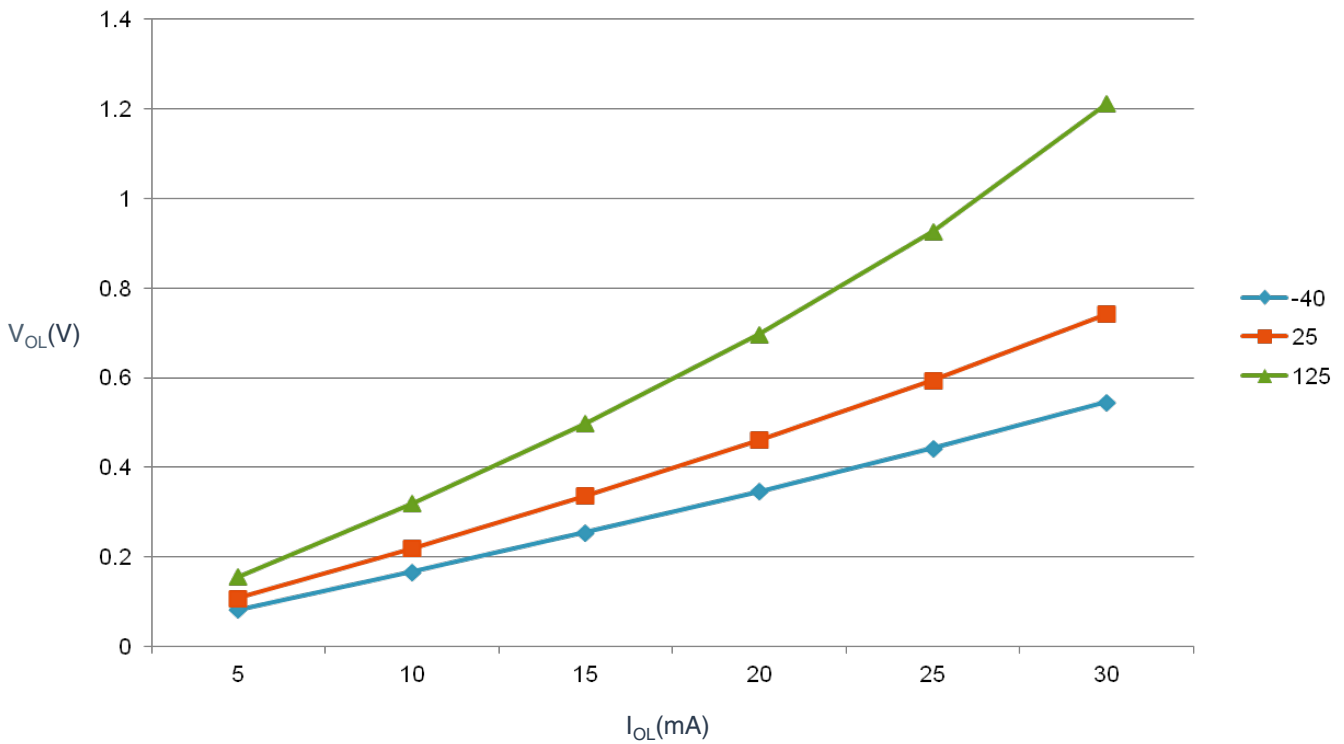

Figure 7. Typical V_{OL} Vs. I_{OL} (high drive strength) ($V_{DD} = 5$ V)

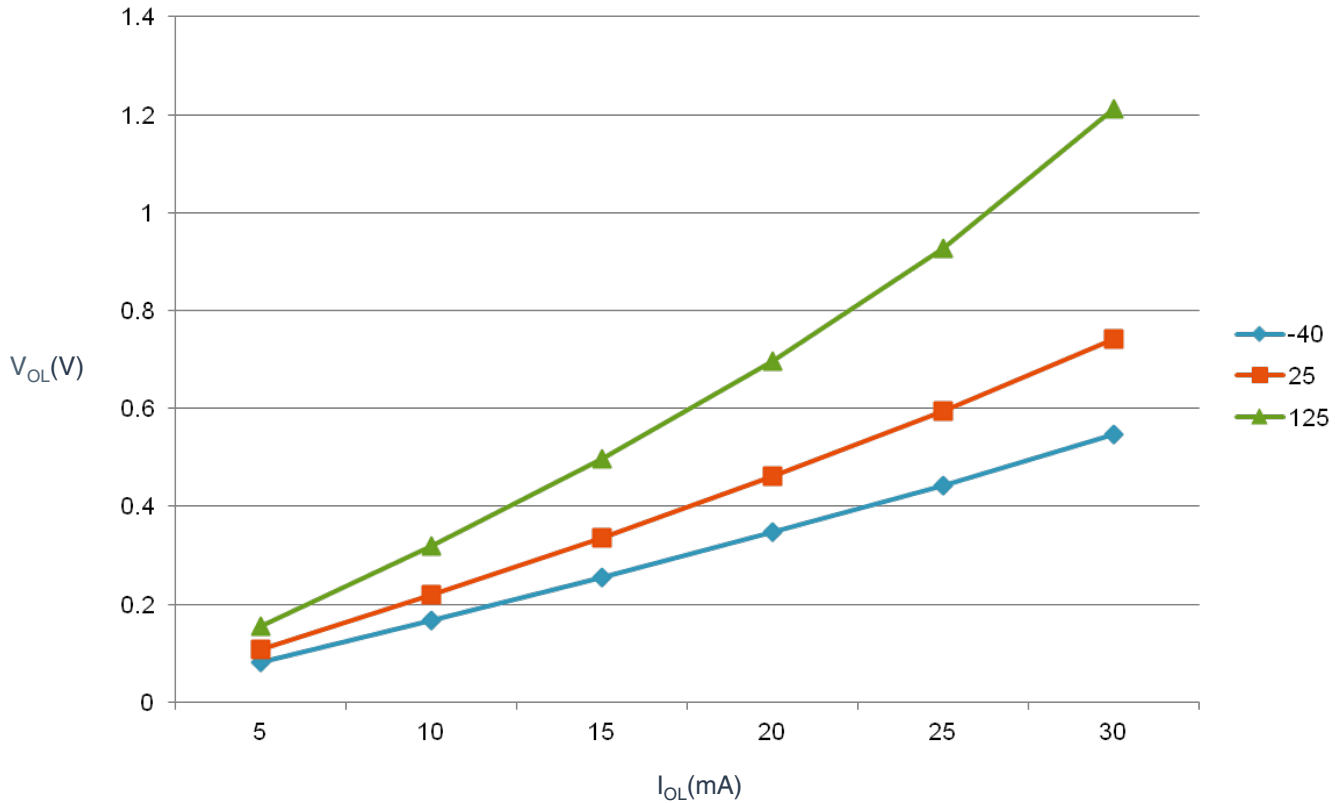

Figure 8. Typical V_{OL} Vs. I_{OL} (high drive strength) ($V_{DD} = 3\text{ V}$)

4.1.2 Supply current characteristics

This section includes information about power supply current in various operating modes.

Table 4. Supply current characteristics

Parameter	Symbol	Bus Freq	V_{DD} (V)	Typical ¹	Max	Unit	Temp
Run supply current FEI mode, all modules clocks enabled; run from flash	$R_{I_{DD}}$	20 MHz	5	6.7	—	mA	-40 to 125 °C
		10 MHz		4.5	—		
		1 MHz		1.5	—		
		20 MHz	3	6.6	—		
		10 MHz		4.4	—		
		1 MHz		1.45	—		
Run supply current FEI mode, all modules clocks disabled; run from flash	$R_{I_{DD}}$	20 MHz	5	5.3	—	mA	-40 to 125 °C
		10 MHz		3.7	—		
		1 MHz		1.5	—		
		20 MHz	3	5.3	—		
		10 MHz		3.7	—		
		1 MHz		1.4	—		

Table continues on the next page...

Table 4. Supply current characteristics (continued)

Parameter	Symbol	Bus Freq	V _{DD} (V)	Typical ¹	Max	Unit	Temp
Run supply current FBE mode, all modules clocks enabled; run from RAM	RI _{DD}	20 MHz	5	9	14.8	mA	-40 to 125 °C
		10 MHz		5.2	—		
		1 MHz		1.45	—		
		20 MHz	3	8.8	11.8		
		10 MHz		5.1	—		
		1 MHz		1.4	—		
Run supply current FBE mode, all modules clocks disabled; run from RAM	RI _{DD}	20 MHz	5	8	12.3	mA	-40 to 125 °C
		10 MHz		4.4	—		
		1 MHz		1.35	—		
		20 MHz	3	7.8	9.2		
		10 MHz		4.2	—		
		1 MHz		1.3	—		
Wait mode current FEI mode, all modules clocks enabled	WI _{DD}	20 MHz	5	5.5	7	mA	-40 to 125 °C
		10 MHz		3.5	—		
		1 MHz		1.4	—		
		20 MHz	3	5.4	6.9		
		10 MHz		3.4	—		
		1 MHz		1.4	—		
Stop mode supply current no clocks active (except 1 kHz LPO clock) ²	SI _{DD}	—	5	2	145	μA	-40 to 125 °C
		—	3	1.9	135		-40 to 125 °C
ADC adder to Stop ADLPC = 1 ADLSMP = 1 ADCO = 1 MODE = 10B ADICLK = 11B	—	—	5	86 (64-pin packages) 42 (32-pin package)	—	μA	-40 to 125 °C
			3	82 (64-pin packages) 41 (32-pin package)	—		
ACMP adder to Stop	—	—	5	12	—	μA	-40 to 125 °C
			3	12	—		
LVD adder to stop ³	—	—	5	128	—	μA	-40 to 125 °C
			3	124	—		

1. Data in Typical column was characterized at 5.0 V, 25 °C or is typical recommended value.
2. RTC adder causes I_{DD} to increase typically by less than 1 μA; RTC clock source is 1 kHz LPO clock.
3. LVD is periodically woken up from Stop by 5% duty cycle. The period is equal to or less than 2 ms.

4.1.3 EMC performance

Electromagnetic compatibility (EMC) performance is highly dependent on the environment in which the MCU resides. Board design and layout, circuit topology choices, location and characteristics of external components as well as MCU software operation play a significant role in EMC performance. The system designer must consult the following NXP applications notes, available on nxp.com for advice and guidance specifically targeted at optimizing EMC performance.

- AN2321: Designing for Board Level Electromagnetic Compatibility
- AN1050: Designing for Electromagnetic Compatibility (EMC) with HCMOS Microcontrollers
- AN1263: Designing for Electromagnetic Compatibility with Single-Chip Microcontrollers
- AN2764: Improving the Transient Immunity Performance of Microcontroller-Based Applications
- AN1259: System Design and Layout Techniques for Noise Reduction in MCU-Based Systems

4.2 Switching specifications

4.2.1 Control timing

Table 5. Control timing

Num	Rating	Symbol	Min	Typical ¹	Max	Unit
1	System and core clock	f_{Sys}	DC	—	40	MHz
2	Bus frequency ($t_{\text{cyc}} = 1/f_{\text{Bus}}$)	f_{Bus}	DC	—	20	MHz
3	Internal low power oscillator frequency	f_{LPO}	0.67	1.0	1.25	KHz
4	External reset pulse width ²	t_{extrst}	$1.5 \times t_{\text{cyc}}$	—	—	ns
5	Reset low drive	t_{rstdrv}	$34 \times t_{\text{cyc}}$	—	—	ns
6	IRQ pulse width	Asynchronous path ²	t_{ILIH}	100	—	ns
		Synchronous path ³	t_{IHIL}	$1.5 \times t_{\text{cyc}}$	—	ns
7	Keyboard interrupt pulse width	Asynchronous path ²	t_{ILIH}	100	—	ns
		Synchronous path	t_{IHIL}	$1.5 \times t_{\text{cyc}}$	—	ns
8	Port rise and fall time - Normal drive strength (load = 50 pF) ⁴	—	t_{Rise}	—	10.2	ns
		—	t_{Fall}	—	9.5	ns
	—	t_{Rise}	—	5.4	—	ns
		t_{Fall}	—	4.6	—	ns

Switching specifications

1. Typical values are based on characterization data at $V_{DD} = 5.0\text{ V}$, $25\text{ }^{\circ}\text{C}$ unless otherwise stated.
2. This is the shortest pulse that is guaranteed to be recognized as a RESET pin request.
3. This is the minimum pulse width that is guaranteed to pass through the pin synchronization circuitry. Shorter pulses may or may not be recognized. In stop mode, the synchronizer is bypassed so shorter pulses can be recognized.
4. Timing is shown with respect to 20% V_{DD} and 80% V_{DD} levels. Temperature range $-40\text{ }^{\circ}\text{C}$ to $125\text{ }^{\circ}\text{C}$.

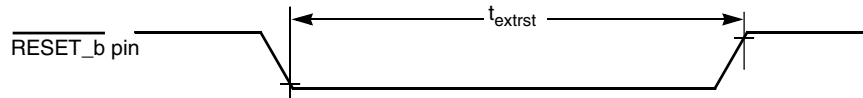

Figure 9. Reset timing

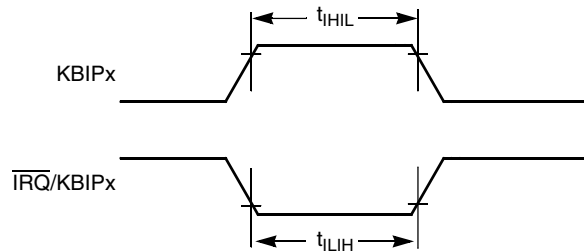

Figure 10. KBIPx timing

4.2.2 FTM module timing

Synchronizer circuits determine the shortest input pulses that can be recognized or the fastest clock that can be used as the optional external source to the timer counter. These synchronizers operate from the current bus rate clock.

Table 6. FTM input timing

Function	Symbol	Min	Max	Unit
External clock frequency	f_{TCLK}	0	$f_{\text{Bus}}/4$	Hz
External clock period	t_{TCLK}	4	—	t_{cyc}
External clock high time	t_{clkh}	1.5	—	t_{cyc}
External clock low time	t_{clkl}	1.5	—	t_{cyc}
Input capture pulse width	t_{ICPW}	1.5	—	t_{cyc}

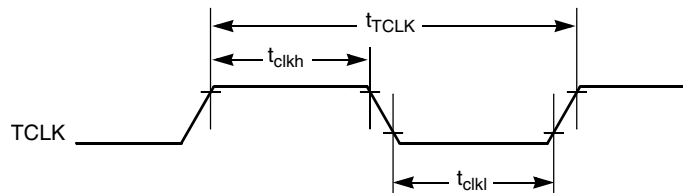

Figure 11. Timer external clock

Peripheral operating requirements and behaviors

4. Thermal resistance between the die and the printed circuit board per JEDEC JESD51-8. Board temperature is measured on the top surface of the board near the package.
5. Thermal resistance between the die and the solder pad on the bottom of the package. Interface resistance is ignored.
6. Thermal characterization parameter indicating the temperature difference between package top and the junction temperature per JEDEC JESD51-2. When Greek letters are not available, the thermal characterization.

The average chip-junction temperature (T_J) in °C can be obtained from:

$$T_J = T_A + (P_D \times \theta_{JA})$$

Where:

T_A = Ambient temperature, °C

θ_{JA} = Package thermal resistance, junction-to-ambient, °C/W

$P_D = P_{int} + P_{I/O}$

$P_{int} = I_{DD} \times V_{DD}$, Watts - chip internal power

$P_{I/O}$ = Power dissipation on input and output pins - user determined

For most applications, $P_{I/O} \ll P_{int}$ and can be neglected. An approximate relationship between P_D and T_J (if $P_{I/O}$ is neglected) is:

$$P_D = K \div (T_J + 273 \text{ °C})$$

Solving the equations above for K gives:

$$K = P_D \times (T_A + 273 \text{ °C}) + \theta_{JA} \times (P_D)^2$$

where K is a constant pertaining to the particular part. K can be determined by measuring P_D (at equilibrium) for an known T_A . Using this value of K, the values of P_D and T_J can be obtained by solving the above equations iteratively for any value of T_A .

5 Peripheral operating requirements and behaviors

5.1 Core modules

5.1.1 SWD electricals

Table 8. SWD full voltage range electricals

Symbol	Description	Min.	Max.	Unit
	Operating voltage	2.7	5.5	V
J1	SWD_CLK frequency of operation			

Table continues on the next page...

5.2 External oscillator (OSC) and ICS characteristics

Table 9. OSC and ICS specifications (temperature range = -40 to 125 °C ambient)

Num	Characteristic		Symbol	Min	Typical ¹	Max	Unit
1	Crystal or resonator frequency	Low range (RANGE = 0)	f_{lo}	31.25	32.768	39.0625	kHz
		High range (RANGE = 1)	f_{hi}	4	—	20	MHz
2	Load capacitors		C1, C2	See Note ²			
3	Feedback resistor	Low Frequency, Low-Power Mode ³	R_F	—	—	—	MΩ
		Low Frequency, High-Gain Mode		—	10	—	MΩ
		High Frequency, Low-Power Mode		—	1	—	MΩ
		High Frequency, High-Gain Mode		—	1	—	MΩ
4	Series resistor - Low Frequency	Low-Power Mode ³	R_S	—	0	—	kΩ
		High-Gain Mode		—	200	—	kΩ
5	Series resistor - High Frequency	Low-Power Mode ³	R_S	—	0	—	kΩ
	Series resistor - High Frequency, High-Gain Mode	4 MHz		—	0	—	kΩ
		8 MHz		—	0	—	kΩ
		16 MHz		—	0	—	kΩ
6	Crystal start-up time low range = 32.768 kHz crystal; High range = 20 MHz crystal ^{4,5}	Low range, low power	t_{CSTL}	—	1000	—	ms
		Low range, high gain		—	800	—	ms
		High range, low power	t_{CSTH}	—	3	—	ms
		High range, high gain		—	1.5	—	ms
7	Internal reference start-up time		t_{IRST}	—	20	50	μs
8	Internal reference clock (IRC) frequency trim range		f_{int_t}	31.25	—	39.0625	kHz
9	Internal reference clock frequency, factory trimmed	T = 125 °C, V _{DD} = 5 V	f_{int_ft}	—	31.25	—	kHz
10	DCO output frequency range	FLL reference = f_{int_t} , f_{lo} , or $f_{hi}/RDIV$	f_{dco}	—	—	—	MHz
11	Factory trimmed internal oscillator accuracy	T = 125 °C, V _{DD} = 5 V	Δf_{int_ft}	-0.8	—	0.8	%
12	Deviation of IRC over temperature when trimmed at T = 25 °C, V _{DD} = 5 V	Over temperature range from -40 °C to 125°C	Δf_{int_t}	-1	—	0.8	%

Table continues on the next page...

5.3 NVM specifications

This section provides details about program/erase times and program/erase endurance for the flash and EEPROM memories.

Table 10. Flash and EEPROM characteristics

Characteristic	Symbol	Min ¹	Typical ²	Max ³	Unit ⁴
Supply voltage for program/erase -40 °C to 125 °C	$V_{\text{prog/erase}}$	2.7	—	5.5	V
Supply voltage for read operation	V_{Read}	2.7	—	5.5	V
NVM Bus frequency	f_{NVMBUS}	1	—	20	MHz
NVM Operating frequency	f_{NVMOP}	0.8	1	1.05	MHz
Erase Verify All Blocks	t_{VFYALL}	—	—	2605	t_{cyc}
Erase Verify Flash Block	t_{RD1BLK}	—	—	2579	t_{cyc}
Erase Verify EEPROM Block	t_{RD1BLK}	—	—	810	t_{cyc}
Erase Verify Flash Section	t_{RD1SEC}	—	—	485	t_{cyc}
Erase Verify EEPROM Section	t_{DRD1SEC}	—	—	555	t_{cyc}
Read Once	t_{RDONCE}	—	—	464	t_{cyc}
Program Flash (2 word)	t_{PGM2}	0.12	0.13	0.31	ms
Program Flash (4 word)	t_{PGM4}	0.21	0.21	0.49	ms
Program Once	t_{PGMONCE}	0.20	0.21	0.21	ms
Program EEPROM (1 Byte)	t_{DPGM1}	0.10	0.10	0.27	ms
Program EEPROM (2 Byte)	t_{DPGM2}	0.17	0.18	0.43	ms
Program EEPROM (3 Byte)	t_{DPGM3}	0.25	0.26	0.60	ms
Program EEPROM (4 Byte)	t_{DPGM4}	0.32	0.33	0.77	ms
Erase All Blocks	t_{ERSALL}	95.42	100.18	100.30	ms
Erase Flash Block	t_{ERSBLK}	95.42	100.18	100.30	ms
Erase Flash Sector	t_{ERSPG}	19.10	20.05	20.09	ms
Erase EEPROM Sector	t_{DERSPG}	4.81	5.05	20.57	ms
Unsecure Flash	t_{UNSECU}	95.42	100.19	100.31	ms
Verify Backdoor Access Key	t_{VFYKEY}	—	—	482	t_{cyc}
Set User Margin Level	t_{MLOADU}	—	—	415	t_{cyc}
FLASH Program/erase endurance T_L to T_H = -40 °C to 125 °C	η_{FLPE}	10 k	100 k	—	Cycles
EEPROM Program/erase endurance T_L to T_H = -40 °C to 125 °C	η_{FLPE}	50 k	500 k	—	Cycles
Data retention at an average junction temperature of $T_{\text{Javg}} = 85^\circ\text{C}$ after up to 10,000 program/erase cycles	$t_{\text{D_ret}}$	15	100	—	years

1. Minimum times are based on maximum f_{NVMOP} and maximum f_{NVMBUS}
2. Typical times are based on typical f_{NVMOP} and maximum f_{NVMBUS}
3. Maximum times are based on typical f_{NVMOP} and typical f_{NVMBUS} plus aging
4. $t_{\text{cyc}} = 1 / f_{\text{NVMBUS}}$

Program and erase operations do not require any special power sources other than the normal V_{DD} supply. For more detailed information about program/erase operations, see the Flash Memory Module section in the reference manual.

5.4 Analog

5.4.1 ADC characteristics

Table 11. 5 V 12-bit ADC operating conditions

Characteristic	Conditions	Symbol	Min	Typ ¹	Max	Unit	Comment
Supply voltage	Absolute	V_{DDA}	2.7	—	5.5	V	—
	Delta to V_{DD} ($V_{DD}-V_{DDA}$)	ΔV_{DDA}	-100	0	+100	mV	—
Ground voltage	Delta to V_{SS} ($V_{SS}-V_{SSA}$)	ΔV_{SSA}	-100	0	+100	mV	—
Input voltage		V_{ADIN}	V_{REFL}	—	V_{REFH}	V	—
Input capacitance		C_{ADIN}	—	4.5	5.5	pF	—
Input resistance		R_{ADIN}	—	3	5	k Ω	—
Analog source resistance	12-bit mode	R_{AS}	—	—	2	k Ω	External to MCU
	• $f_{ADCK} > 4$ MHz		—	—	5		
	• $f_{ADCK} < 4$ MHz		—	—	5		
10-bit mode	—	—	5	k Ω	External to MCU		
• $f_{ADCK} > 4$ MHz	—	—	10				
• $f_{ADCK} < 4$ MHz	—	—	10	k Ω	External to MCU		
8-bit mode (all valid f_{ADCK})	—	—	10				
ADC conversion clock frequency	High speed (ADLPC=0)	f_{ADCK}	0.4	—	8.0	MHz	—
	Low power (ADLPC=1)		0.4	—	4.0		

1. Typical values assume $V_{DDA} = 5.0$ V, Temp = 25°C, $f_{ADCK}=1.0$ MHz unless otherwise stated. Typical values are for reference only and are not tested in production.

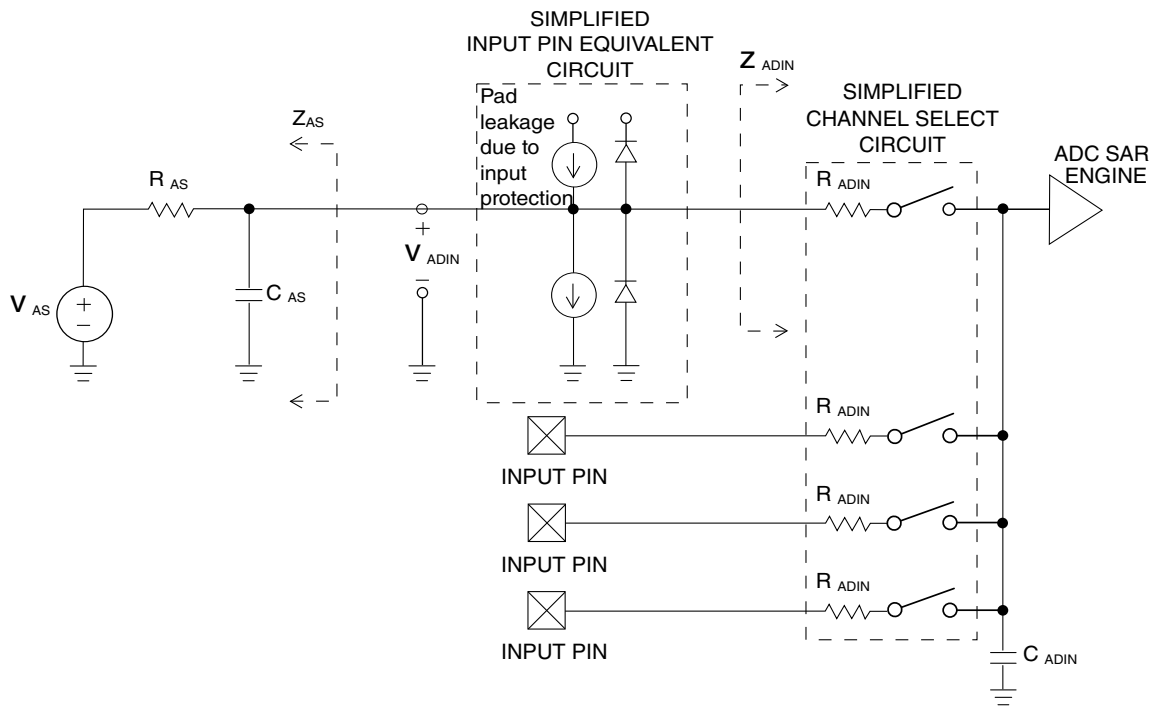

Figure 16. ADC input impedance equivalency diagram

Table 12. 12-bit ADC characteristics ($V_{REFH} = V_{DDA}$, $V_{REFL} = V_{SSA}$)

Characteristic	Conditions	Symbol	Min	Typ ¹	Max	Unit
Supply current		I_{DDA}	—	133	—	μA
ADLPC = 1						
ADLSMP = 1						
ADCO = 1						
Supply current		I_{DDA}	—	218	—	μA
ADLPC = 1						
ADLSMP = 0						
ADCO = 1						
Supply current		I_{DDA}	—	327	—	μA
ADLPC = 0						
ADLSMP = 1						
ADCO = 1						
Supply current		I_{DDA}	—	582	990	μA
ADLPC = 0						
ADLSMP = 0						
ADCO = 1						
Supply current	Stop, reset, module off	I_{DDA}	—	0.011	1	μA
ADC asynchronous clock source	High speed (ADLPC = 0)	f_{ADACK}	2	3.3	5	MHz

Table continues on the next page...

Table 12. 12-bit ADC characteristics ($V_{REFH} = V_{DDA}$, $V_{REFL} = V_{SSA}$) (continued)

Characteristic	Conditions	Symbol	Min	Typ ¹	Max	Unit
	Low power (ADLPC = 1)		1.25	2	3.3	
Conversion time (including sample time)	Short sample (ADLSMP = 0)	t_{ADC}	—	20	—	ADCK cycles
	Long sample (ADLSMP = 1)		—	40	—	
Sample time	Short sample (ADLSMP = 0)	t_{ADS}	—	3.5	—	ADCK cycles
	Long sample (ADLSMP = 1)		—	23.5	—	
Total unadjusted Error ²	12-bit mode	E_{TUE}	—	±5.0	—	LSB ³
	10-bit mode		—	±1.5	±2.0	
	8-bit mode		—	±0.7	±1.0	
Differential Non-Linearity	12-bit mode	DNL	—	±1.0	—	LSB ³
	10-bit mode ⁴		—	±0.25	±0.5	
	8-bit mode ⁴		—	±0.15	±0.25	
Integral Non-Linearity	12-bit mode	INL	—	±1.0	—	LSB ³
	10-bit mode		—	±0.3	±0.5	
	8-bit mode		—	±0.15	±0.25	
Zero-scale error ⁵	12-bit mode	E_{ZS}	—	±2.0	—	LSB ³
	10-bit mode		—	±0.25	±1.0	
	8-bit mode		—	±0.65	±1.0	
Full-scale error ⁶	12-bit mode	E_{FS}	—	±2.5	—	LSB ³
	10-bit mode		—	±0.5	±1.0	
	8-bit mode		—	±0.5	±1.0	
Quantization error	≤12 bit modes	E_Q	—	—	±0.5	LSB ³
Input leakage error ⁷	all modes	E_{IL}	$I_{in} \times R_{AS}$			mV
Temp sensor slope	-40 °C–25 °C	m	—	3.266	—	mV/°C
	25 °C–125 °C		—	3.638	—	
Temp sensor voltage	25 °C	V_{TEMP25}	—	1.396	—	V

1. Typical values assume $V_{DDA} = 5.0$ V, Temp = 25 °C, $f_{ADCK} = 1.0$ MHz unless otherwise stated. Typical values are for reference only and are not tested in production.
2. Includes quantization
3. $1 \text{ LSB} = (V_{REFH} - V_{REFL})/2^N$
4. Monotonicity and no-missing-codes guaranteed in 10-bit and 8-bit modes
5. $V_{ADIN} = V_{SSA}$
6. $V_{ADIN} = V_{DDA}$
7. I_{in} = leakage current (refer to DC characteristics)

5.4.2 Analog comparator (ACMP) electricals

Table 13. Comparator electrical specifications

Characteristic	Symbol	Min	Typical	Max	Unit
Supply voltage	V_{DDA}	2.7	—	5.5	V
Supply current (Operation mode)	I_{DDA}	—	10	20	μ A
Analog input voltage	V_{AIN}	$V_{SS} - 0.3$	—	V_{DDA}	V
Analog input offset voltage	V_{AIO}	—	—	40	mV
Analog comparator hysteresis (HYST=0)	V_H	—	15	20	mV
Analog comparator hysteresis (HYST=1)	V_H	—	20	30	mV
Supply current (Off mode)	I_{DDAOFF}	—	60	—	nA
Propagation Delay	t_D	—	0.4	1	μ s

5.5 Communication interfaces

5.5.1 SPI switching specifications

The serial peripheral interface (SPI) provides a synchronous serial bus with master and slave operations. Many of the transfer attributes are programmable. The following tables provide timing characteristics for classic SPI timing modes. See the SPI chapter of the chip's reference manual for information about the modified transfer formats used for communicating with slower peripheral devices. All timing is shown with respect to 20% V_{DD} and 80% V_{DD} , unless noted, and 25 pF load on all SPI pins. All timing assumes slew rate control is disabled and high-drive strength is enabled for SPI output pins.

Table 14. SPI master mode timing

Num.	Symbol	Description	Min.	Max.	Unit	Comment
1	f_{op}	Frequency of operation	$f_{Bus}/2048$	$f_{Bus}/2$	Hz	f_{Bus} is the bus clock
2	t_{SPSCK}	SPSCK period	$2 \times t_{Bus}$	$2048 \times t_{Bus}$	ns	$t_{Bus} = 1/f_{Bus}$
3	t_{Lead}	Enable lead time	1/2	—	t_{SPSCK}	—
4	t_{Lag}	Enable lag time	1/2	—	t_{SPSCK}	—
5	t_{WSPSCK}	Clock (SPSCK) high or low time	$t_{Bus} - 30$	$1024 \times t_{Bus}$	ns	—
6	t_{SU}	Data setup time (inputs)	8	—	ns	—
7	t_{HI}	Data hold time (inputs)	8	—	ns	—
8	t_v	Data valid (after SPSCK edge)	—	25	ns	—
9	t_{HO}	Data hold time (outputs)	20	—	ns	—

Table continues on the next page...

Table 14. SPI master mode timing (continued)

Nu m.	Symbol	Description	Min.	Max.	Unit	Comment
10	t_{RI}	Rise time input	—	$t_{Bus} - 25$	ns	—
	t_{FI}	Fall time input	—			
11	t_{RO}	Rise time output	—	25	ns	—
	t_{FO}	Fall time output	—			

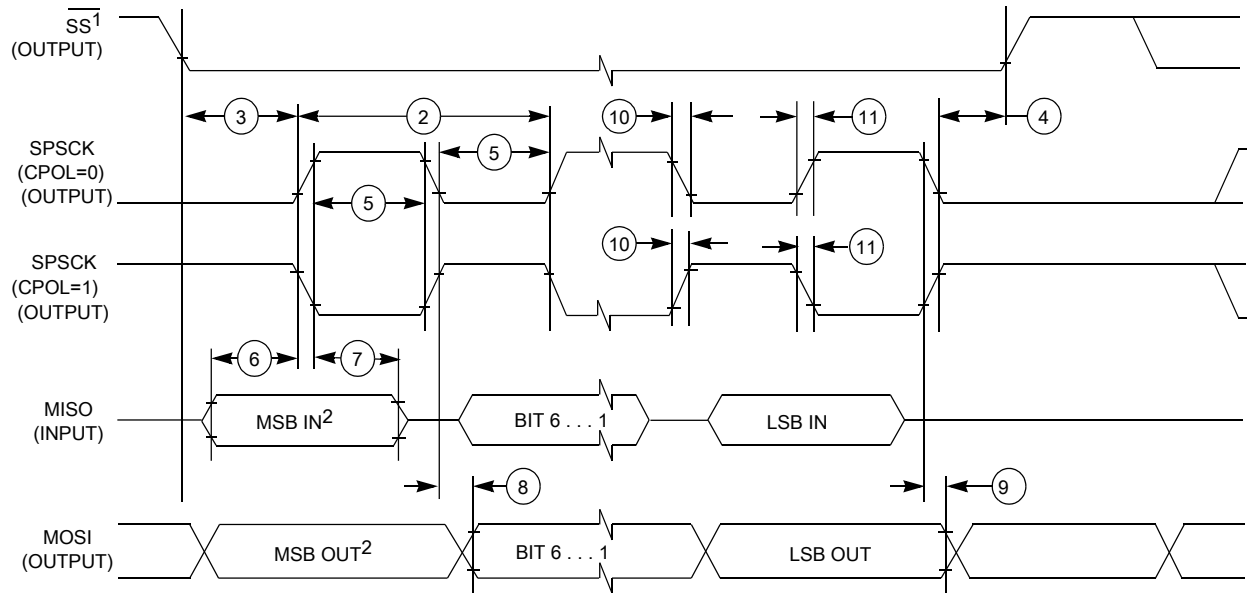

1. If configured as an output.
2. LSBF = 0. For LSBF = 1, bit order is LSB, bit 1, ..., bit 6, MSB.

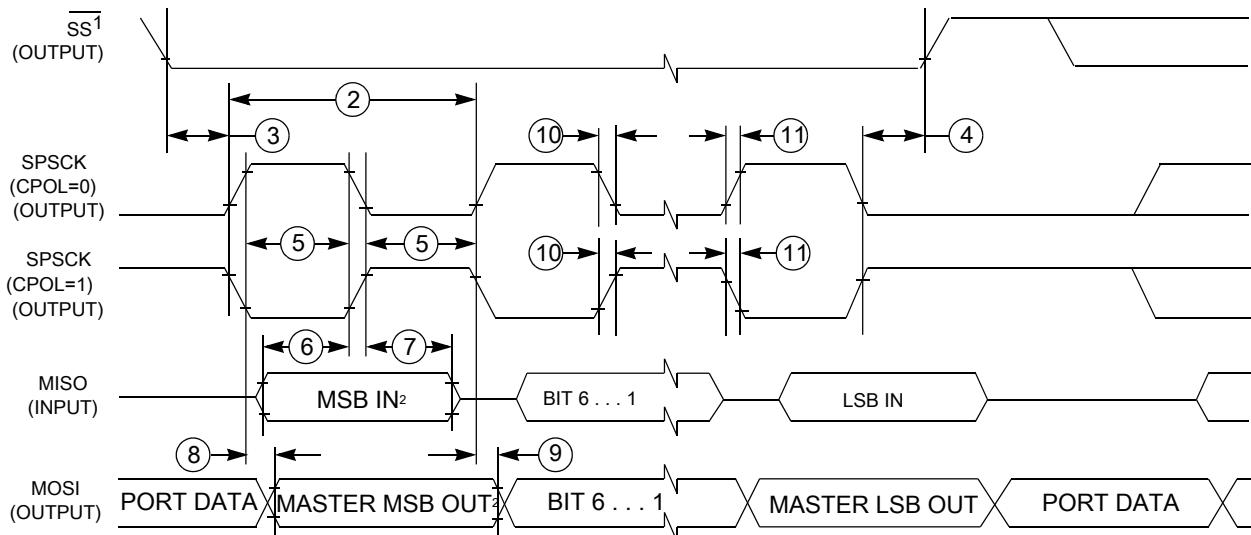
Figure 17. SPI master mode timing (CPHA=0)

1. If configured as output
2. LSBF = 0. For LSBF = 1, bit order is LSB, bit 1, ..., bit 6, MSB.

Figure 18. SPI master mode timing (CPHA=1)

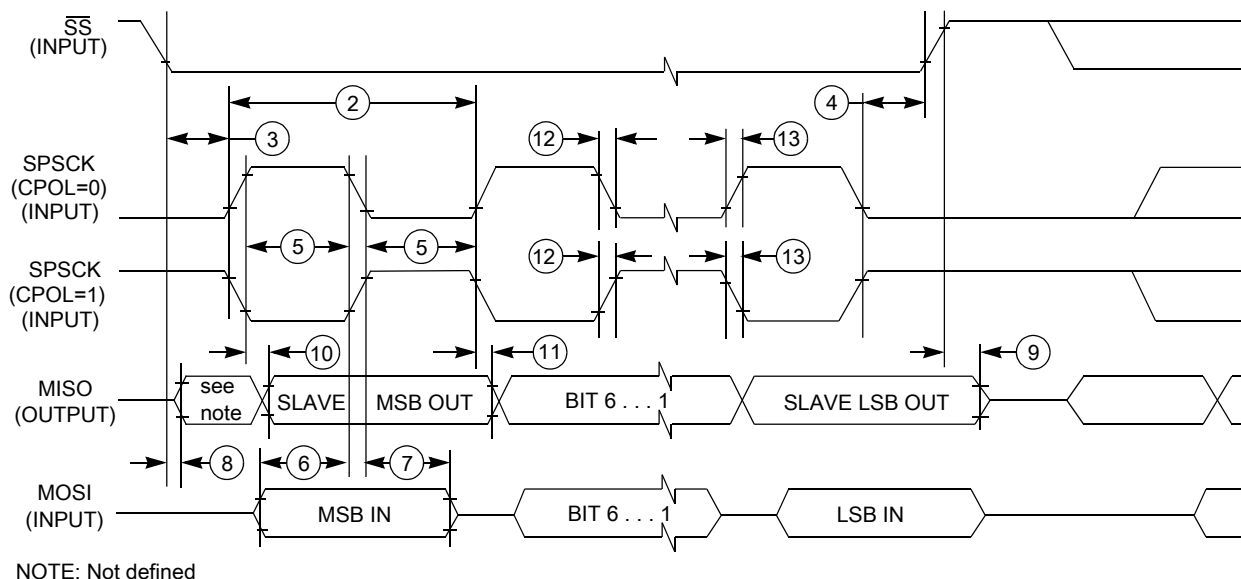

Figure 20. SPI slave mode timing (CPHA=1)

6 Dimensions

6.1 Obtaining package dimensions

Package dimensions are provided in package drawings.

To find a package drawing, go to nxp.com and perform a keyword search for the drawing's document number:

If you want the drawing for this package	Then use this document number
32-pin LQFP	98ASH70029A
64-pin LQFP	98ASS23234W

7 Pinout

7.1 Signal multiplexing and pin assignments

For the pin muxing details see section Signal Multiplexing and Signal Descriptions of KEA64 Reference Manual.

8 Revision History

The following table provides a revision history for this document.

Table 16. Revision History

Rev. No.	Date	Substantial Changes
Rev. 1	11 March 2014	Initial Release
Rev. 2	18 June 2014	<ul style="list-style-type: none"> • Parameter Classification section is removed. • Classification column is removed from all the tables in the document. • Supply current characteristics section is updated.
Rev. 3	18 July 2014	<ul style="list-style-type: none"> • ESD handling ratings section is updated. • Figures in DC characteristics section are updated. • Specs updated in following tables: <ul style="list-style-type: none"> • Table 9. • Table 4.
Rev. 4	03 Sept 2014	<ul style="list-style-type: none"> • Data Sheet type changed to "Technical Data".
Rev. 5	12 May 2016	<ul style="list-style-type: none"> • In section: Key features, Changed the number of instances of IIC to 1.