

Welcome to E-XFL.COM

What is "[Embedded - Microcontrollers](#)"?

"[Embedded - Microcontrollers](#)" refer to small, integrated circuits designed to perform specific tasks within larger systems. These microcontrollers are essentially compact computers on a single chip, containing a processor core, memory, and programmable input/output peripherals. They are called "embedded" because they are embedded within electronic devices to control various functions, rather than serving as standalone computers. Microcontrollers are crucial in modern electronics, providing the intelligence and control needed for a wide range of applications.

Applications of "[Embedded - Microcontrollers](#)"

Details

Product Status	Obsolete
Core Processor	Z8
Core Size	8-Bit
Speed	12MHz
Connectivity	-
Peripherals	POR, WDT
Number of I/O	14
Program Memory Size	1KB (1K x 8)
Program Memory Type	OTP
EEPROM Size	-
RAM Size	125 x 8
Voltage - Supply (Vcc/Vdd)	4.5V ~ 5.5V
Data Converters	-
Oscillator Type	Internal
Operating Temperature	0°C ~ 70°C (TA)
Mounting Type	Through Hole
Package / Case	18-DIP (0.300", 7.62mm)
Supplier Device Package	-
Purchase URL	https://www.e-xfl.com/product-detail/zilog/z86e0412psc1866

FEATURES

- 14 Input/Output Lines
- Six Vectored, Prioritized Interrupts (3 falling edge, 1 rising edge, 2 timers)
- Two Analog Comparators
- Program Options:
 - Low Noise
 - ROM Protect
 - Auto Latch
 - Watch-Dog Timer (WDT)
 - EPROM/Test Mode Disable
- Two Programmable 8-Bit Counter/Timers, Each with 6-Bit Programmable Prescaler
- WDT/ Power-On Reset (POR)
- On-Chip Oscillator that Accepts XTAL, Ceramic Resonance, LC, RC, or External Clock
- Clock-Free WDT Reset
- Low-Power Consumption (50 mw typical)
- Fast Instruction Pointer (1 μ s @ 12 MHz)
- RAM Bytes (125)

GENERAL DESCRIPTION

Zilog's Z86E04/E08 Microcontrollers (MCU) are One-Time Programmable (OTP) members of Zilog's single-chip Z8[®] MCU family that allow easy software development, debug, prototyping, and small production runs not economically desirable with masked ROM versions.

For applications demanding powerful I/O capabilities, the Z86E04/E08's dedicated input and output lines are grouped into three ports, and are configurable under software control to provide timing, status signals, or parallel I/O.

Two on-chip counter/timers, with a large number of user selectable modes, offload the system of administering real-time tasks such as counting/timing and I/O data communications.

Note: All signals with an overline, " $\bar{}$ ", are active Low, for example: $\overline{B/W}$ (WORD is active Low); \overline{B}/W (BYTE is active Low, only).

Power connections follow conventional descriptions below:

Connection	Circuit	Device
Power	V _{CC}	V _{DD}
Ground	GND	V _{SS}

GENERAL DESCRIPTION (Continued)

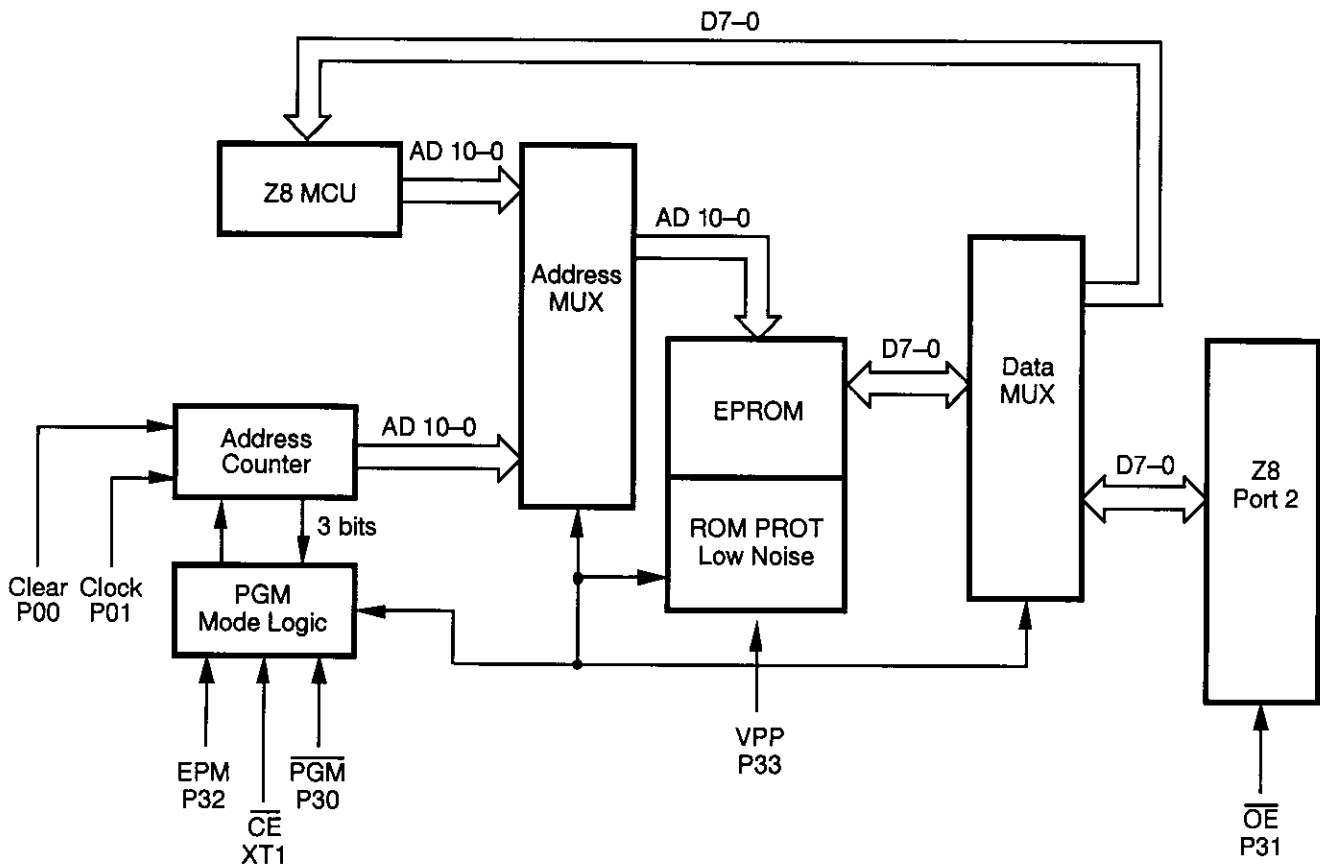

Figure 2. EPROM Programming Mode Block Diagram

STANDARD TEST CONDITIONS

The characteristics listed below apply for standard test conditions as noted. All voltages are referenced to Ground. Positive current flows into the referenced pin (Figure 5).

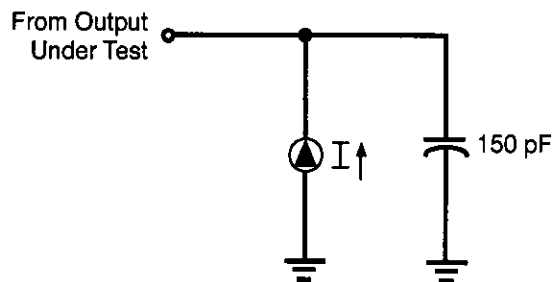

Figure 5. Test Load Diagram

CAPACITANCE

$T_A = 25^\circ\text{C}$, $V_{CC} = \text{GND} = 0\text{V}$, $f = 1.0\text{ MHz}$, unmeasured pins returned to GND.

Parameter	Min	Max
Input capacitance	0	10 pF
Output capacitance	0	20 pF
I/O capacitance	0	25 pF

Sym	Parameter	V _{CC} [4]	T _A = 0°C to +70°C Typical		Units	Conditions	Notes
			Min	Max @ 25°C			
I _{CC}	Supply Current	4.5V	11.0	6.8	mA	All Output and I/O Pins Floating @ 2 MHz	5,7
		5.5V	11.0	6.8	mA	All Output and I/O Pins Floating @ 2 MHz	5,7
		4.5V	15.0	8.2	mA	All Output and I/O Pins Floating @ 8 MHz	5,7
		5.5V	15.0	8.2	mA	All Output and I/O Pins Floating @ 8 MHz	5,7
		4.5V	20.0	12.0	mA	All Output and I/O Pins Floating @ 12 MHz	5,7
		5.5V	20.0	12.0	mA	All Output and I/O Pins Floating @ 12 MHz	5,7
I _{CC1}	Standby Current	4.5V	4.0	2.5	mA	HALT Mode V _{IN} = 0V, V _{CC} @ 2 MHz	5,7
		5.5V	4.0	2.5	mA	HALT Mode V _{IN} = 0V, V _{CC} @ 2 MHz	5,7
		4.5V	5.0	3.0	mA	HALT Mode V _{IN} = 0V, V _{CC} @ 8 MHz	5,7
		5.5V	5.0	3.0	mA	HALT Mode V _{IN} = 0V, V _{CC} @ 8 MHz	5,7
		4.5V	7.0	4.0	mA	HALT Mode V _{IN} = 0V, V _{CC} @ 12 MHz	5,7
		5.5V	7.0	4.0	mA	HALT Mode V _{IN} = 0V, V _{CC} @ 12 MHz	5,7
I _{CC}	Supply Current (Low Noise Mode)	4.5V	11.0	6.8	mA	All Output and I/O Pins Floating @ 1 MHz	7
		5.5V	11.0	6.8	mA	All Output and I/O Pins Floating @ 1 MHz	7
		4.5V	13.0	7.5	mA	All Output and I/O Pins Floating @ 2 MHz	7
		5.5V	13.0	7.5	mA	All Output and I/O Pins Floating @ 2 MHz	7
		4.5V	15.0	8.2	mA	All Output and I/O Pins Floating @ 4 MHz	7
		5.5V	15.0	8.2	mA	All Output and I/O Pins Floating @ 4 MHz	7

DC ELECTRICAL CHARACTERISTICS (Continued)

Sym	Parameter	V _{CC} [4]	T _A = 0°C to +70°C		Typical @ 25°C	Units	Conditions	Notes
			Min	Max				
I _{CC1}	Standby Current (Low Noise Mode)	4.5V	4.0	2.5	mA	HALT Mode V _{IN} = 0V, V _{CC} @ 1 MHz	7	
		5.5V	4.0	2.5	mA	HALT Mode V _{IN} = 0V, V _{CC} @ 1 MHz	7	
		4.5V	4.5	2.8	mA	HALT Mode V _{IN} = 0V, V _{CC} @ 2 MHz	7	
		5.5V	4.5	2.8	mA	HALT Mode V _{IN} = 0V, V _{CC} @ 2 MHz	7	
		4.5V	5.0	3.0	mA	HALT Mode V _{IN} = 0V, V _{CC} @ 4 MHz	7	
		5.5V	5.0	3.0	mA	HALT Mode V _{IN} = 0V, V _{CC} @ 4 MHz	7	
I _{CC2}	Standby Current	4.5V	10.0	1.0	μA	STOP Mode V _{IN} = 0V, V _{CC} WDT is not Running	7,8	
		5.5V	10.0	1.0	μA	STOP Mode V _{IN} = 0V, V _{CC} WDT is not Running	7,8	
I _{ALL}	Auto Latch Low Current	4.5V	32.0	16	μA	0V < V _{IN} < V _{CC}		
		5.5V	32.0	16	μA	0V < V _{IN} < V _{CC}		
I _{ALH}	Auto Latch High Current	4.5V	-16.0	-8.0	μA	0V < V _{IN} < V _{CC}		
		5.5V	-16.0	-8.0	μA	0V < V _{IN} < V _{CC}		

Notes:

1. Port 2 and Port 0 only
2. V_{SS} = 0V = GND
3. The device operates down to V_{LV} of the specified frequency for V_{LV}. The minimum operational V_{CC} is determined on the value of the voltage V_{LV} at the ambient temperature. The V_{LV} increases as the temperature decreases.
4. V_{CC} = 4.5 to 5.5V, typical values measured at V_{CC} = 5.0V.
The V_{CC} voltage specification of 5.5 V guarantees 5.0 V ± 0.5V with typical values measured at V_{CC} = 5.0V.
5. Standard Mode (not Low EMI Mode)
6. Z86E08 only
7. All outputs unloaded and all inputs are at V_{CC} or V_{SS} level.
8. If analog comparator is selected, then the comparator inputs must be at V_{CC} level.

DC ELECTRICAL CHARACTERISTICS

Extended Temperature

Sym	Parameter	V _{CC} [4]	T _A = -40°C to +105°C		Typical @ 25°C	Units	Conditions	Notes
			Min	Max				
V _{INMAX}	Max Input Voltage	4.5V		12.0		V	I _{IN} < 250 μA	1
		5.5V		12.0		V	I _{IN} < 250 μA	1
V _{CH}	Clock Input High Voltage	4.5V	0.8 V _{CC}	V _{CC} +0.3	2.8	V	Driven by External Clock Generator	
		5.5V	0.8 V _{CC}	V _{CC} +0.3	2.8	V	Driven by External Clock Generator	
V _{CL}	Clock Input Low Voltage	4.5V	V _{SS} -0.3	0.2 V _{CC}	1.7	V	Driven by External Clock Generator	
		5.5V	V _{SS} -0.3	0.2 V _{CC}	1.7	V	Driven by External Clock Generator	
V _{IH}	Input High Voltage	4.5V	0.7 V _{CC}	V _{CC} +0.3	2.8	V		
		5.5V	0.7 V _{CC}	V _{CC} +0.3	2.8	V		
V _{IL}	Input Low Voltage	4.5V	V _{SS} -0.3	0.2 V _{CC}	1.5	V		
		5.5V	V _{SS} -0.3	0.2 V _{CC}	1.5	V		
V _{OH}	Output High Voltage	4.5V	V _{CC} -0.4		4.8	V	I _{OH} = -2.0 mA	5
		5.5V	V _{CC} -0.4		4.8	V	I _{OH} = -2.0 mA	5
		4.5V	V _{CC} -0.4			V	Low Noise @ I _{OH} = -0.5 mA	
		5.5V	V _{CC} -0.4			V	Low Noise @ I _{OH} = -0.5 mA	
V _{OL1}	Output Low Voltage	4.5V		0.4	0.1	V	I _{OL} = +4.0 mA	5
		5.5V		0.4	0.1	V	I _{OL} = +4.0 mA	5
		4.5V		0.4	0.1	V	Low Noise @ I _{OL} = 1.0 mA	
		5.5V		0.4	0.1	V	Low Noise @ I _{OL} = 1.0 mA	
V _{OL2}	Output Low Voltage	4.5V		1.0	0.3	V	I _{OL} = +12 mA,	5
		5.5V		1.0	0.3	V	I _{OL} = +12 mA,	5
V _{OFFSET}	Comparator Input Offset Voltage	4.5V		25.0	10.0	mV		
		5.5V		25.0	10.0	mV		
V _{LV}	V _{CC} Low Voltage Auto Reset		1.8	3.8	2.8	V	@ 6 MHz Max. Int. CLK Freq.	3
I _{IL}	Input Leakage (Input Bias Current of Comparator)	4.5V		-1.0	1.0	μA	V _{IN} = 0V, V _{CC}	
		5.5V		-1.0	1.0	μA	V _{IN} = 0V, V _{CC}	
I _{OL}	Output Leakage	4.5V		-1.0	1.0	μA	V _{IN} = 0V, V _{CC}	
		5.5V		-1.0	1.0	μA	V _{IN} = 0V, V _{CC}	
V _{ICR}	Comparator Input Common Mode Voltage Range		0	V _{CC} -1.5		V		

Sym	Parameter	V _{CC} [4]	T _A = -40°C to +105°C		Typical @ 25°C	Units	Conditions	Notes
			Min	Max				
I _{CC1}	Standby Current (Low Noise Mode)	4.5V		4.0	2.5	mA	HALT Mode V _{IN} = 0V, V _{CC} @ 1 MHz	7
		5.5V		4.0	2.5	mA	HALT Mode V _{IN} = 0V, V _{CC} @ 1 MHz	7
		4.5V		4.5	2.8	mA	HALT Mode V _{IN} = 0V, V _{CC} @ 2 MHz	7
		5.5V		4.5	2.8	mA	HALT Mode V _{IN} = 0V, V _{CC} @ 2 MHz	7
		4.5V		5.0	3.0	mA	HALT Mode V _{IN} = 0V, V _{CC} @ 4 MHz	7
		5.5V		5.0	3.0	mA	HALT Mode V _{IN} = 0V, V _{CC} @ 4 MHz	7
I _{CC2}	Standby Current	4.5V		20	1.0	μA	STOP Mode V _{IN} = 0V, V _{CC} WDT is not Running	7,8
		5.5V		20	1.0	μA	STOP Mode V _{IN} = 0V, V _{CC} WDT is not Running	7,8
I _{ALL}	Auto Latch Low Current	4.5V		40	16	μA	0V < V _{IN} < V _{CC}	
		5.5V		40	16	μA	0V < V _{IN} < V _{CC}	
I _{ALH}	Auto Latch High Current	4.5V		-20.0	-8.0	μA	0V < V _{IN} < V _{CC}	
		5.5V		-20.0	-8.0	μA	0V < V _{IN} < V _{CC}	

Notes:

1. Port 2 and Port 0 only
2. V_{SS} = 0V = GND
3. The device operates down to V_{LV} of the specified frequency for V_{LV}. The minimum operational V_{CC} is determined on the value of the voltage V_{LV} at the ambient temperature. The V_{LV} increases as the temperature decreases.
4. V_{CC} = 4.5V to 5.5V, typical values measured at V_{CC} = 5.0V
5. Standard Mode (not Low EMI Mode)
6. Z86E08 only
7. All outputs unloaded and all inputs are at V_{CC} or V_{SS} level.
8. If analog comparator is selected, then the comparator inputs must be at V_{CC} level.

AC ELECTRICAL CHARACTERISTICS (Continued)

Low Noise Mode, Extended Temperature

No	Symbol	Parameter	V _{CC}	T _A = -40 °C to +105 °C				Units	Notes
				1 MHz		4 MHz			
				Min	Max	Min	Max		
1	TPC	Input Clock Period	4.5V	1000	DC	250	DC	ns	1
			5.5V	1000	DC	250	DC	ns	1
2	TrC TfC	Clock Input Rise and Fall Times	4.5V		25		25	ns	1
			5.5V		25		25	ns	1
3	TwC	Input Clock Width	4.5V	500		125		ns	1
			5.5V	500		125		ns	1
4	TwTinL	Timer Input Low Width	4.5V	70		70		ns	1
			5.5V	70		70		ns	1
5	TwTinH	Timer Input High Width	4.5V	2.5TpC		2.5TpC			1
			5.5V	2.5TpC		2.5TpC			1
6	TpTin	Timer Input Period	4.5V		4TpC	4TpC			1
			5.5V		4TpC	4TpC			1
7	TrTin, TtTin	Timer Input Rise and Fall Time	4.5V		100		100	ns	1
			5.5V		100		100	ns	1
8	TwIL	Int. Request Input Low Time	4.5V	70		70		ns	1,2
			5.5V	70		70		ns	1,2
9	TwIH	Int. Request Input High Time	4.5V	2.5TpC		2.5TpC			1,2
			5.5V	2.5TpC		2.5TpC			1,2
10	Twdt	Watch-Dog Timer Delay Time for Timeout	4.5V	10		10		ms	1
			5.5V	10		10		ms	1

Notes:

1. Timing Reference uses 0.7 V_{CC} for a logic 1 and 0.2 V_{CC} for a logic 0.
2. Interrupt request through Port 3 (P33–P31).

LOW NOISE VERSION

Low EMI Emission

The Z86E04/E08 can be programmed to operate in a Low EMI Emission Mode by means of a mask ROM bit option. Use of this feature results in:

- All pre-driver slew rates reduced to 10 ns typical.
- Internal SCLK/TCLK operation limited to a maximum of 4 MHz–250 ns cycle time.

- Output drivers have resistances of 500 Ohms (typical).
- Oscillator divide-by-two circuitry eliminated.

The Low EMI Mode is mask-programmable to be selected by the customer at the time the ROM code is submitted.

PIN FUNCTIONS

OTP Programming Mode

D7–D0 Data Bus. Data can be read from, or written to, the EPROM through this data bus.

V_{CC} Power Supply. It is typically 5V during EPROM Read Mode and 6.4V during the other modes (Program, Program Verify, and so on).

\overline{CE} Chip Enable (active Low). This pin is active during EPROM Read Mode, Program Mode, and Program Verify Mode.

\overline{OE} Output Enable (active Low). This pin drives the Data Bus direction. When this pin is Low, the Data Bus is output. When High, the Data Bus is input.

EPM EPROM Program Mode. This pin controls the different EPROM Program Modes by applying different voltages.

V_{PP} Program Voltage. This pin supplies the program voltage.

Clear Clear (active High). This pin resets the internal address counter at the High Level.

Clock Address Clock. This pin is a clock input. The internal address counter increases by one with one clock cycle.

\overline{PGM} Program Mode (active Low). A Low level at this pin programs the data to the EPROM through the Data Bus.

Application Precaution

The production test-mode environment may be enabled accidentally during normal operation if **excessive noise** surges above V_{CC} occur on the XTAL1 pin.

In addition, processor operation of Z8 OTP devices may be affected by **excessive noise** surges on the V_{PP}, \overline{CE} , EPM, \overline{OE} pins while the microcontroller is in Standard Mode.

Recommendations for dampening voltage surges in both test and OTP Mode include the following:

- Using a clamping diode to V_{CC}.
- Adding a capacitor to the affected pin.

Note: Programming the EPROM/Test Mode Disable option will prevent accidental entry into EPROM Mode or Test Mode.

Port 2, P27–P20. Port 2 is an 8-bit, bit programmable, bi-directional, Schmitt-triggered CMOS-compatible I/O port. These eight I/O lines can be configured under software

control to be inputs or outputs, independently. Bits programmed as outputs can be globally programmed as either push-pull or open-drain (Figure 8).

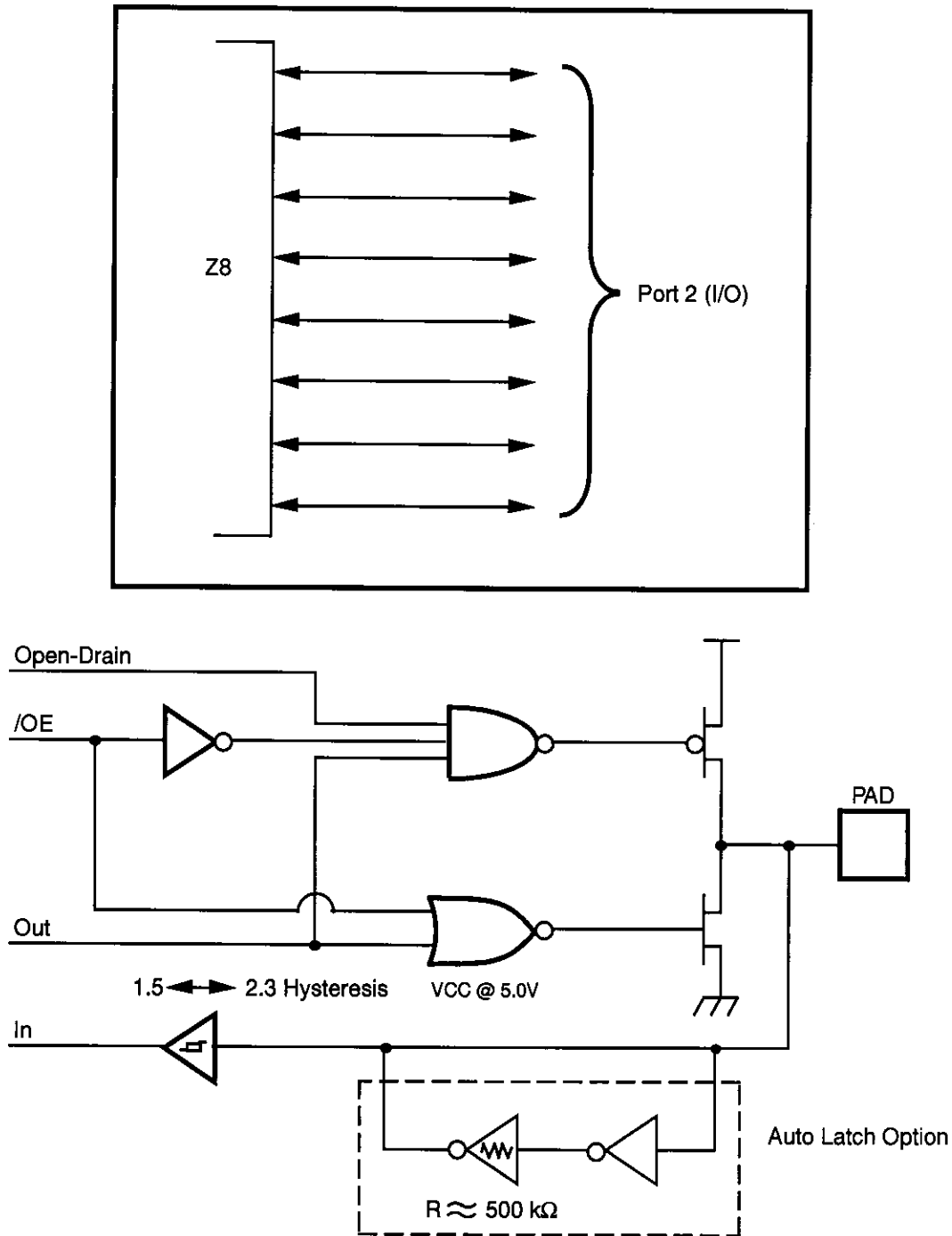
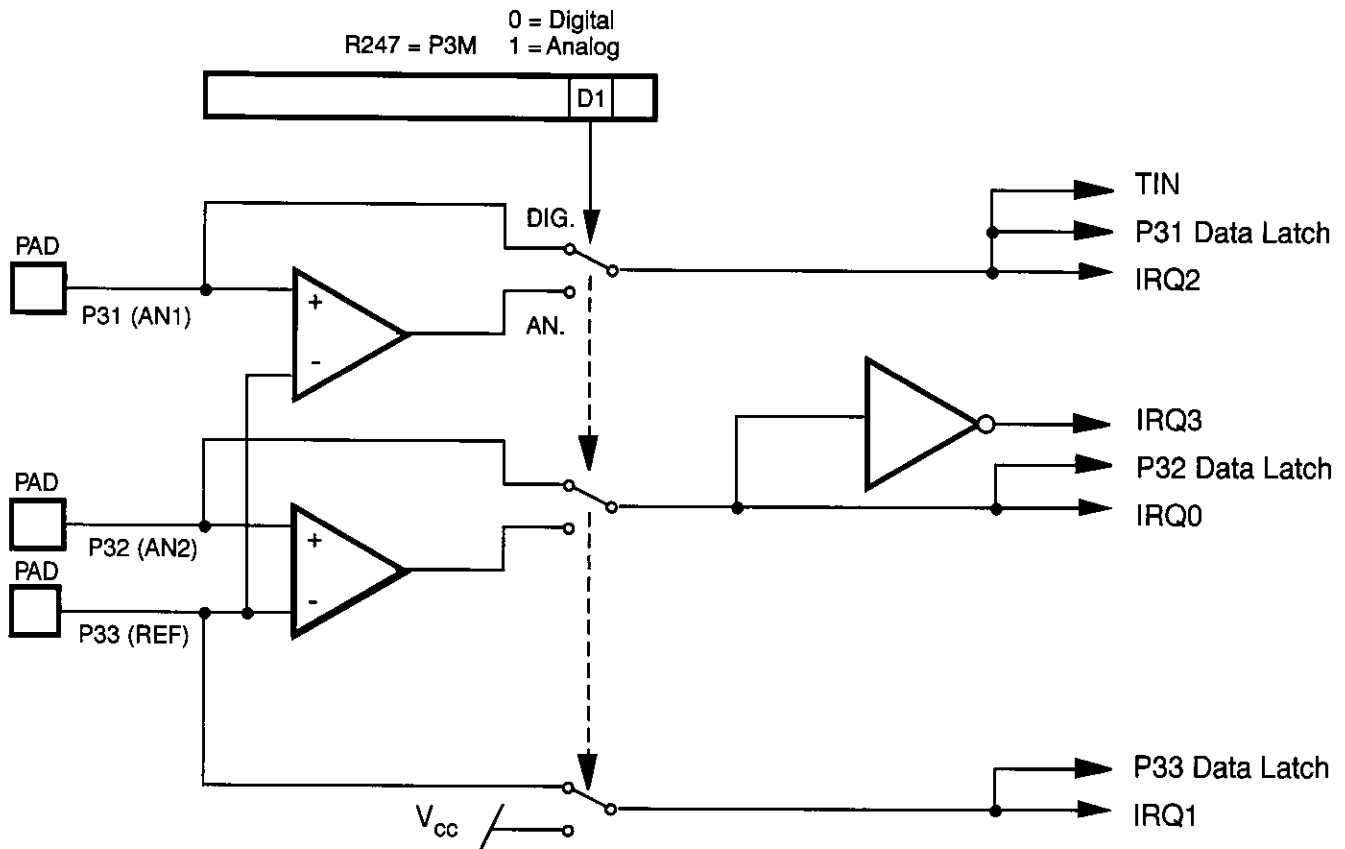
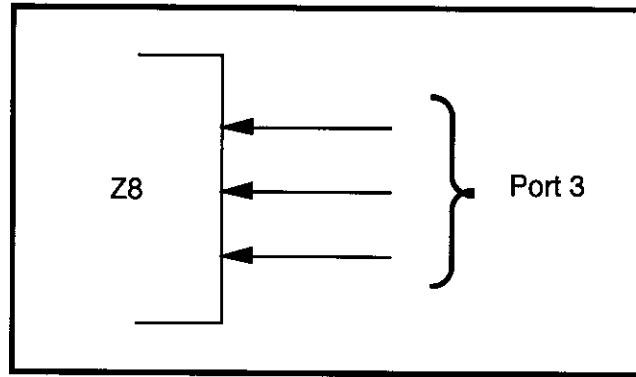

Figure 8. Port 2 Configuration

PIN FUNCTIONS (Continued)

Port 3, P33–P31. Port 3 is a 3-bit, CMOS-compatible port with three fixed input (P33–P31) lines. These three input lines can be configured under software control as digital Schmitt-trigger inputs or analog inputs.

These three input lines are also used as the interrupt sources IRQ0–IRQ3, and as the timer input signal T_{IN} (Figure 9).



IRQ 0,1,2 = Falling Edge Detection
IRQ3 = Rising Edge Detection

Figure 9. Port 3 Configuration

Clock. The Z8 on-chip oscillator has a high-gain, parallel-resonant amplifier for connection to a crystal, LC, RC, ceramic resonator, or any suitable external clock source (XTAL1 = INPUT, XTAL2 = OUTPUT). The crystal should be AT cut, up to 12 MHz max., with a series resistance (RS) of less than or equal to 100 Ohms.

The crystal should be connected across XTAL1 and XTAL2 using the vendors crystal recommended capacitors from each pin directly to device ground pin 14 (Figure 16). Note that the crystal capacitor loads should be connected to V_{SS}, Pin 14 to reduce Ground noise injection.



* Typical value including pin parasitics

Figure 16. Oscillator Configuration

HALT Mode. This instruction turns off the internal CPU clock but not the crystal oscillation. The counter/timers and external interrupts IRQ0, IRQ1, IRQ2 and IRQ3 remain active. The device is recovered by interrupts, either externally or internally generated. An interrupt request must be executed (enabled) to exit HALT Mode. After the interrupt service routine, the program continues from the instruction after the HALT.

Note: On the C12 ICEBOX, the IRQ3 does not wake the device out of HALT Mode.

STOP Mode. This instruction turns off the internal clock and external crystal oscillation and reduces the standby current to 10 μ A. The STOP Mode is released by a RESET through a Stop-Mode Recovery (pin P27). A Low input condition on P27 releases the STOP Mode. Program execution begins at location 000C(Hex). However, when P27 is used to release the STOP Mode, the I/O port Mode registers are not reconfigured to their default power-on conditions. This prevents any I/O, configured as output when the STOP instruction was executed, from glitching to an unknown state. To use the P27 release approach with STOP Mode, use the following instruction:

```
LD          P2M, #1XXX XXXXB
NOP
STOP
```

X = Dependent on user's application.

Note: A low level detected on P27 pin will take the device out of STOP Mode even if configured as an output.

In order to enter STOP or HALT Mode, it is necessary to first flush the instruction pipeline to avoid suspending execution in mid-instruction. To do this, the user executes a NOP (opcode=FFH) immediately before the appropriate SLEEP instruction, such as:

```
FF      NOP      ; clear the pipeline
6F      STOP     ; enter STOP Mode
        or
FF      NOP      ; clear the pipeline
7F      HALT     ; enter HALT Mode
```

Watch-Dog Timer (WDT). The Watch-Dog Timer is enabled by instruction WDT. When the WDT is enabled, it cannot be stopped by the instruction. With the WDT instruction, the WDT is refreshed when it is enabled within every 1 Twdt period; otherwise, the controller resets itself. The WDT instruction affects the flags accordingly; Z=1, S=0, V=0.

WDT = 5F (Hex)

Opcode WDT (5FH). The first time Opcode 5FH is executed, the WDT is enabled and subsequent execution clears the WDT counter. This must be done at least every T_{WDT} ; otherwise, the WDT times out and generates a reset. The generated reset is the same as a power-on reset of T_{POR} , plus 18 XTAL clock cycles. The software enabled WDT does not run in STOP Mode.

Opcode WDH (4FH). When this instruction is executed it enables the WDT during HALT. If not, the WDT stops when entering HALT. This instruction does not clear the counters, it just makes it possible to have the WDT running during HALT Mode. A WDH instruction executed without executing WDT (5FH) has no effect.

Permanent WDT. Selecting the hardware enabled Permanent WDT option, will automatically enable the WDT upon exiting reset. The permanent WDT will always run in HALT Mode and STOP Mode, and it cannot be disabled.

Auto Reset Voltage (V_{LV}). The Z8 has an auto-reset built-in. The auto-reset circuit resets the Z8 when it detects the V_{CC} below V_{LV} .

Figure 17 shows the Auto Reset Voltage versus temperature. If the V_{CC} drops below the VCC operating voltage range, the Z8 will function down to the V_{LV} unless the internal clock frequency is higher than the specified maximum V_{LV} frequency.

FUNCTIONAL DESCRIPTION (Continued)

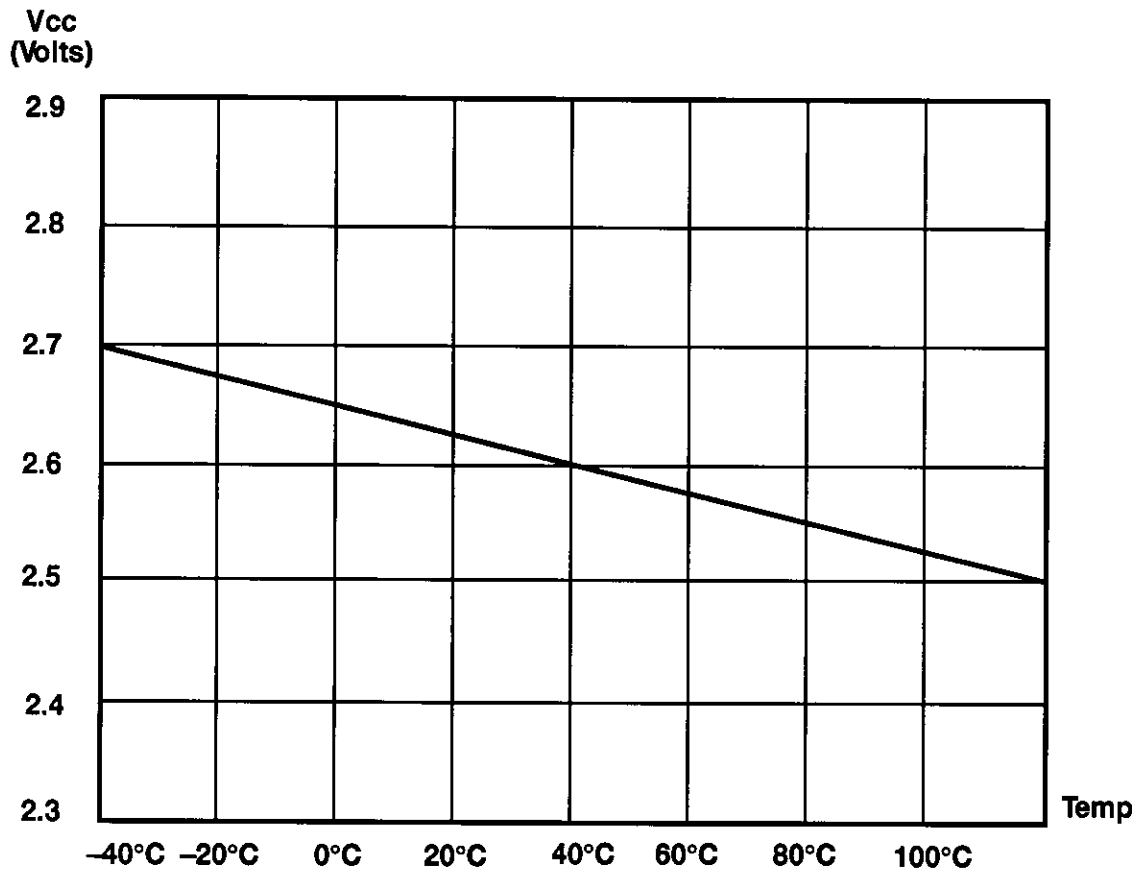

Figure 17. Typical Auto Reset Voltage (V_{LV}) vs. Temperature

FUNCTIONAL DESCRIPTION (Continued)

Internal Address Counter. The address of Z8 is generated internally with a counter clocked through pin P01 (Clock). Each clock signal increases the address by one and the "high" level of pin P00 (Clear) will reset the address to zero. Figure 18 shows the setup time of the serial address input.

Programming Waveform. Figures 19, 20, 21 and 22 show the programming waveforms of each mode. Table 8 shows the timing of programming waveforms.

Programming Algorithm. Figure 23 shows the flow chart of the Z8 programming algorithm.

Table 8. Timing of Programming Waveforms

Parameters	Name	Min	Max	Units
1	Address Setup Time	2		μ s
2	Data Setup Time	2		μ s
3	V _{pp} Setup	2		μ s
4	V _{cc} Setup Time	2		μ s
5	Chip Enable Setup Time	2		μ s
6	Program Pulse Width	0.95		ms
7	Data Hold Time	2		μ s
8	OE Setup Time	2		μ s
9	Data Access Time	188		ns
10	Data Output Float Time		100	ns
11	Overprogram Pulse Width	2.85		ms
12	EPM Setup Time	2		μ s
13	PGM Setup Time	2		μ s
14	Address to OE Setup Time	2		μ s
15	Option Program Pulse Width	78		ms
16	OE Width	250		ns
17	Address Valid to OE Low	125		ns

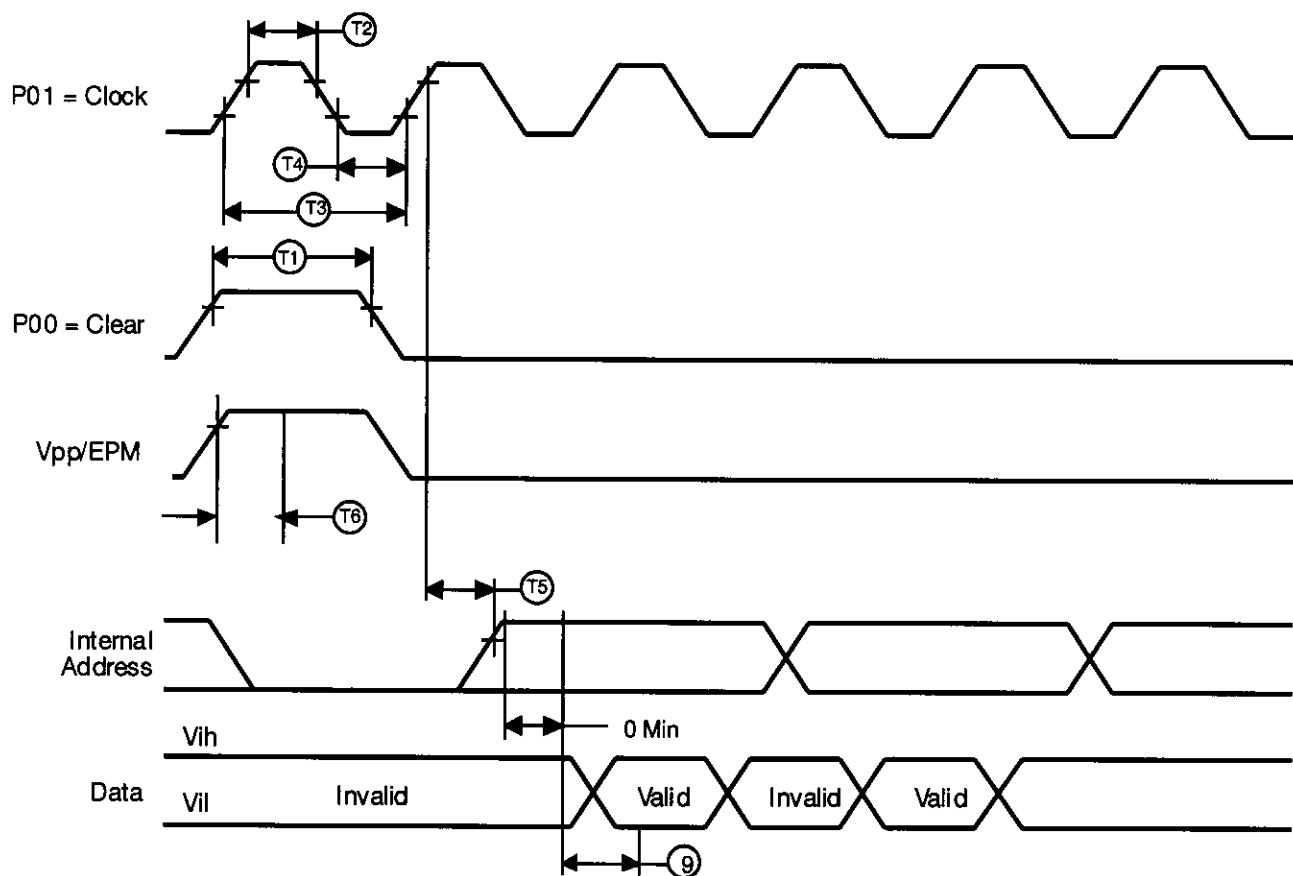

Legend:	
T1 Reset Clock Width	30 ns Min
T2 Input Clock High	100 ns Min
T3 Input Clock Period	200 ns Min
T4 Input Clock Low	100 ns Min
T5 Clock to Address Counter Out Delay	15 ns Max
T6 Epm/Vpp Set up Time	40 μ s Min

Figure 18. Z86E04/E08 Address Counter Waveform

FUNCTIONAL DESCRIPTION (Continued)

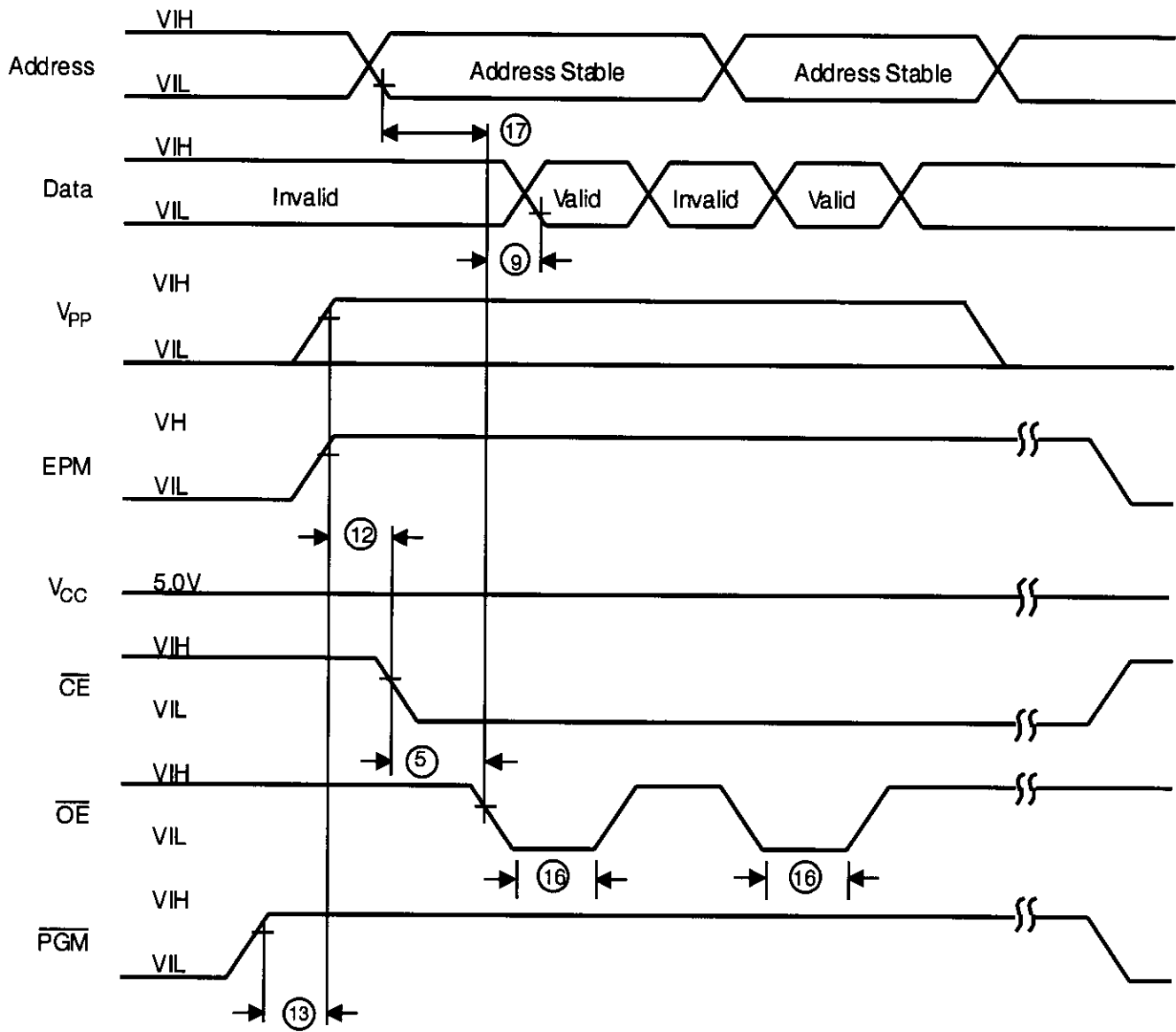

Figure 19. Z86E04/E08 Programming Waveform
(EPROM Read)

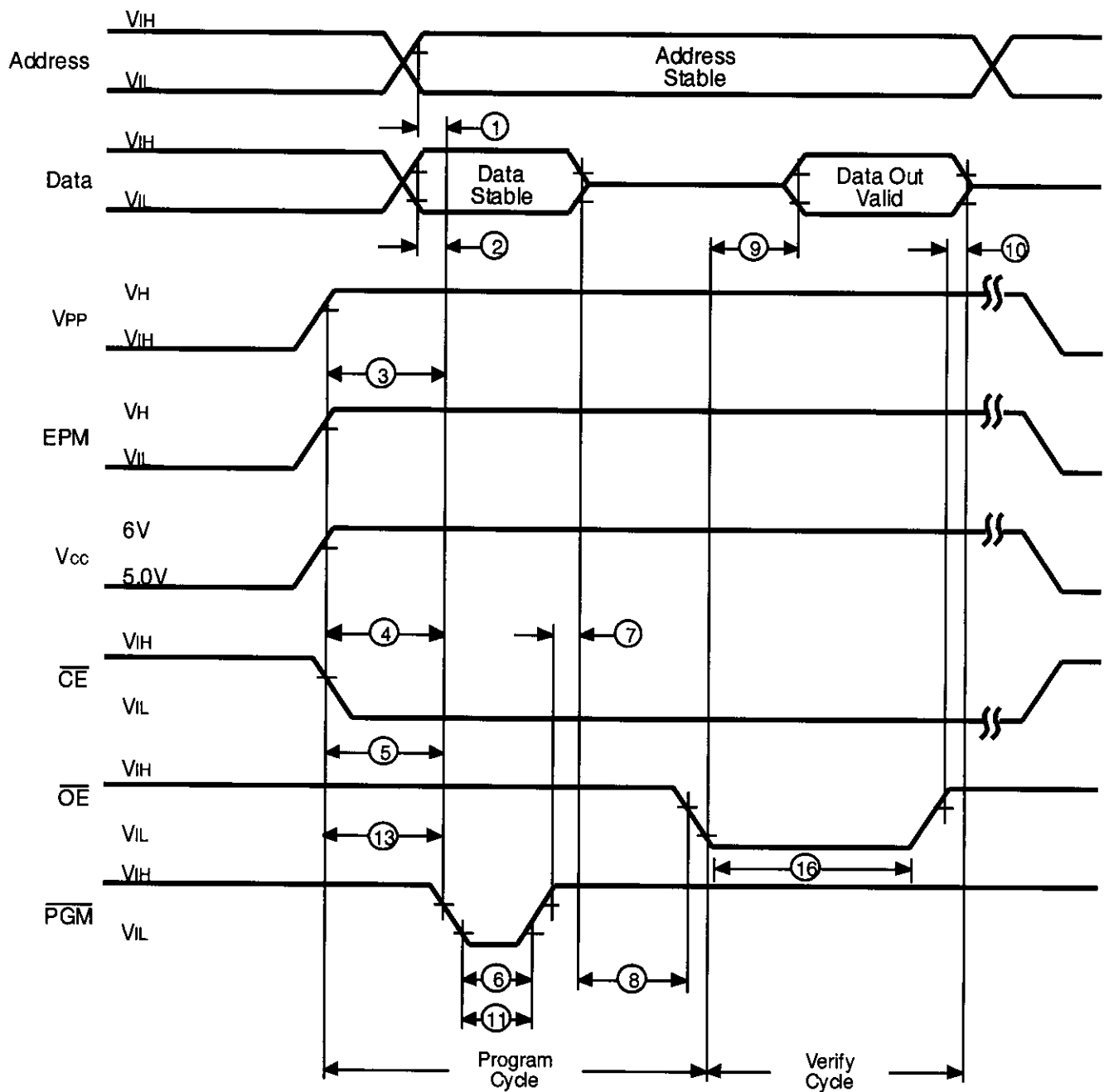

Figure 20. Z86E04/E08 Programming Waveform
(Program and Verify)

FUNCTIONAL DESCRIPTION (Continued)

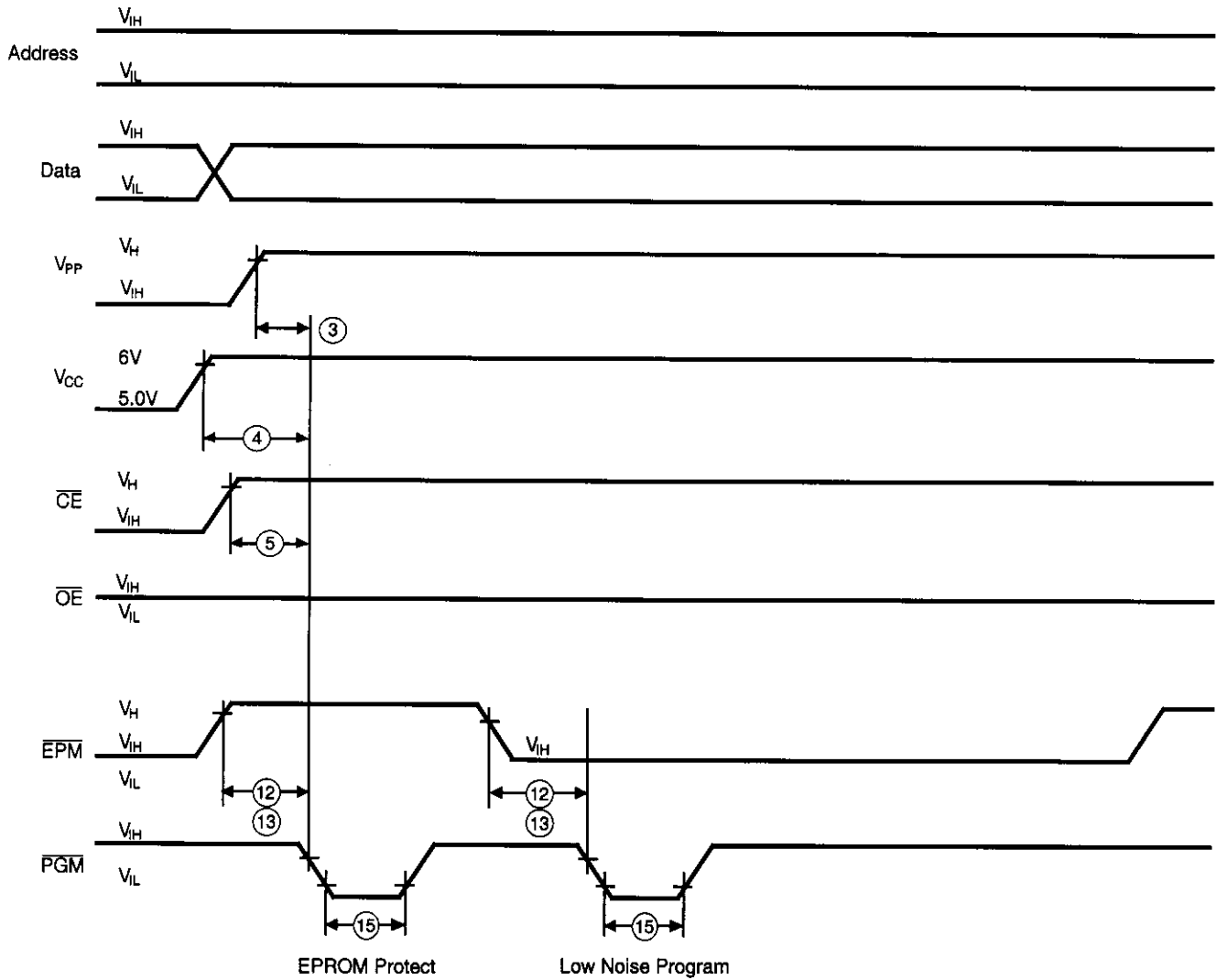

Figure 21. Z86E04/E08 Programming Options Waveform
(EPROM Protect and Low Noise Program)

Z8 CONTROL REGISTERS

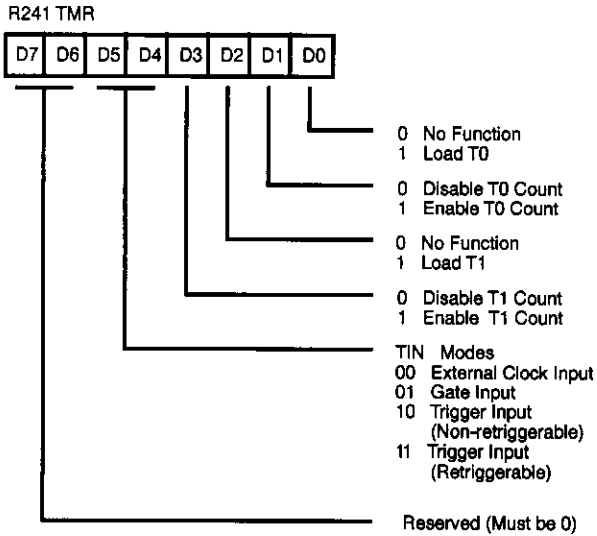

Figure 24. Timer Mode Register (F1_H: Read/Write)

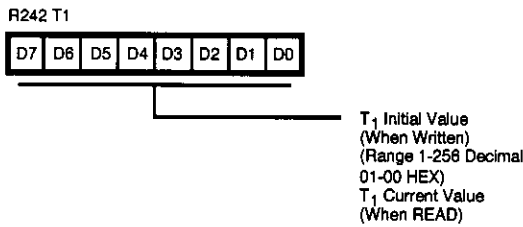

Figure 25. Counter Timer 1 Register (F2_H: Read/Write)

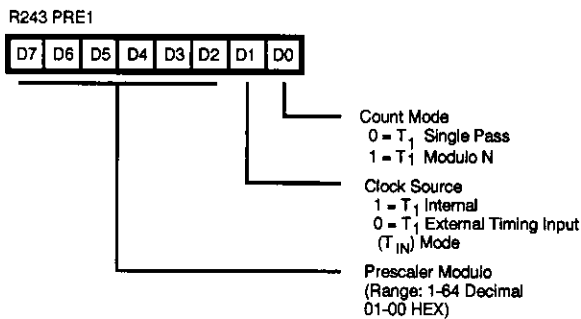

Figure 26. Prescaler 1 Register (F3_H: Write Only)

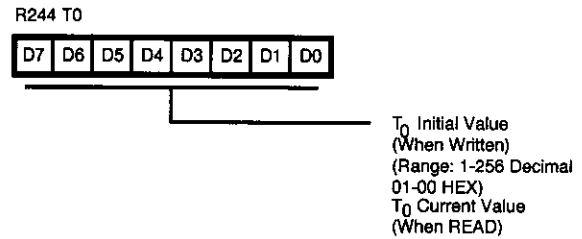

Figure 27. Counter/Timer 0 Register (F4_H: Read/Write)

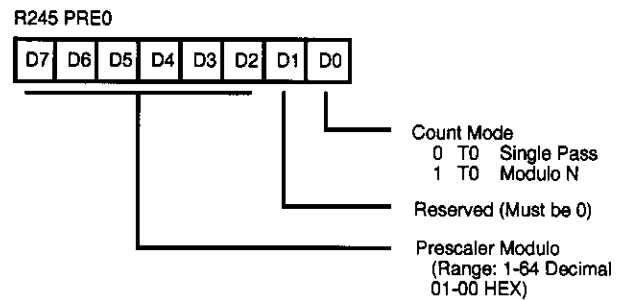

Figure 28. Prescaler 0 Register (F5_H: Write Only)

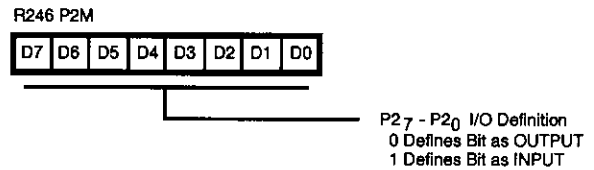

Figure 29. Port 2 Mode Register (F6_H: Write Only)

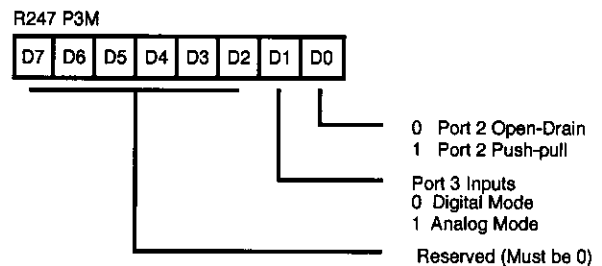

Figure 30. Port 3 Mode Register (F7_H: Write Only)