

Welcome to [E-XFL.COM](https://www.e-xfl.com)

Understanding Embedded - FPGAs (Field Programmable Gate Array)

Embedded - FPGAs, or Field Programmable Gate Arrays, are advanced integrated circuits that offer unparalleled flexibility and performance for digital systems. Unlike traditional fixed-function logic devices, FPGAs can be programmed and reprogrammed to execute a wide array of logical operations, enabling customized functionality tailored to specific applications. This reprogrammability allows developers to iterate designs quickly and implement complex functions without the need for custom hardware.

Applications of Embedded - FPGAs

The versatility of Embedded - FPGAs makes them indispensable in numerous fields. In telecommunications.

Details

Product Status	Active
Number of LABs/CLBs	-
Number of Logic Elements/Cells	768
Total RAM Bits	-
Number of I/O	66
Number of Gates	30000
Voltage - Supply	1.425V ~ 1.575V
Mounting Type	Surface Mount
Operating Temperature	0°C ~ 70°C (TA)
Package / Case	81-WFBGA, CSBGA
Supplier Device Package	81-UCSP (4x4)
Purchase URL	https://www.e-xfl.com/product-detail/microchip-technology/agl030v5-ucg81

Summary of I/O Timing Characteristics – Default I/O Software Settings

Table 2-29 • Summary of AC Measuring Points

Standard	Measuring Trip Point (Vtrip)
3.3 V LVTTTL / 3.3 V LVCMOS	1.4 V
3.3 V VCMOS Wide Range	1.4 V
2.5 V LVCMOS	1.2 V
1.8 V LVCMOS	0.90 V
1.5 V LVCMOS	0.75 V
1.2 V LVCMOS	0.60 V
1.2 V LVCMOS Wide Range	0.60 V
3.3 V PCI	0.285 * VCCI (RR)
	0.615 * VCCI (FF)
3.3 V PCI-X	0.285 * VCCI (RR)
	0.615 * VCCI (FF)

Table 2-30 • I/O AC Parameter Definitions

Parameter	Parameter Definition
t_{DP}	Data to Pad delay through the Output Buffer
t_{PY}	Pad to Data delay through the Input Buffer
t_{DOUT}	Data to Output Buffer delay through the I/O interface
t_{EOUT}	Enable to Output Buffer Tristate Control delay through the I/O interface
t_{DIN}	Input Buffer to Data delay through the I/O interface
t_{HZ}	Enable to Pad delay through the Output Buffer—High to Z
t_{ZH}	Enable to Pad delay through the Output Buffer—Z to High
t_{LZ}	Enable to Pad delay through the Output Buffer—Low to Z
t_{ZL}	Enable to Pad delay through the Output Buffer—Z to Low
t_{ZHS}	Enable to Pad delay through the Output Buffer with delayed enable—Z to High
t_{ZLS}	Enable to Pad delay through the Output Buffer with delayed enable—Z to Low

Single-Ended I/O Characteristics

3.3 V LVTTTL / 3.3 V LVCMOS

Low-Voltage Transistor–Transistor Logic (LVTTTL) is a general-purpose standard (EIA/JESD) for 3.3 V applications. It uses an LVTTTL input buffer and push-pull output buffer. Furthermore, all LVCMOS 3.3 V software macros comply with LVCMOS 3.3 V wide range as specified in the JESD8a specification.

Table 2-47 • Minimum and Maximum DC Input and Output Levels
Applicable to Advanced I/O Banks

3.3 V LVTTTL / 3.3 V LVCMOS	VIL		VIH		VOL	VOH	IOL	IOH	IOSL	IOSH	IIL ¹	IIH ²
	Min. V	Max. V	Min. V	Max. V	Max. V	Min. V	mA	mA	Max. mA ³	Max. mA ³	μA ⁴	μA ⁴
2 mA	-0.3	0.8	2	3.6	0.4	2.4	2	2	25	27	10	10
4 mA	-0.3	0.8	2	3.6	0.4	2.4	4	4	25	27	10	10
6 mA	-0.3	0.8	2	3.6	0.4	2.4	6	6	51	54	10	10
8 mA	-0.3	0.8	2	3.6	0.4	2.4	8	8	51	54	10	10
12 mA	-0.3	0.8	2	3.6	0.4	2.4	12	12	103	109	10	10
16 mA	-0.3	0.8	2	3.6	0.4	2.4	16	16	132	127	10	10
24 mA	-0.3	0.8	2	3.6	0.4	2.4	24	24	268	181	10	10

Notes:

1. IIL is the input leakage current per I/O pin over recommended operation conditions where $-0.3\text{ V} < V_{IN} < V_{IL}$.
2. IIH is the input leakage current per I/O pin over recommended operating conditions $V_{IH} < V_{IN} < V_{CCI}$. Input current is larger when operating outside recommended ranges.
3. Currents are measured at 100°C junction temperature and maximum voltage.
4. Currents are measured at 85°C junction temperature.
5. Software default selection highlighted in gray.

Table 2-48 • Minimum and Maximum DC Input and Output Levels
Applicable to Standard Plus I/O Banks

3.3 V LVTTTL / 3.3 V LVCMOS	VIL		VIH		V _{OL}	VOH	IOL	IOH	IOSL	IOSH	IIL ¹	IIH ²
	Min. V	Max. V	Min. V	Max. V	Max. V	Min. V	mA	mA	Max. mA ³	Max. mA ³	μA ⁴	μA ⁴
2 mA	-0.3	0.8	2	3.6	0.4	2.4	2	2	25	27	10	10
4 mA	-0.3	0.8	2	3.6	0.4	2.4	4	4	25	27	10	10
6 mA	-0.3	0.8	2	3.6	0.4	2.4	6	6	51	54	10	10
8 mA	-0.3	0.8	2	3.6	0.4	2.4	8	8	51	54	10	10
12 mA	-0.3	0.8	2	3.6	0.4	2.4	12	12	103	109	10	10
16 mA	-0.3	0.8	2	3.6	0.4	2.4	16	16	103	109	10	10

Notes:

1. IIL is the input leakage current per I/O pin over recommended operation conditions where $-0.3\text{ V} < V_{IN} < V_{IL}$.
2. IIH is the input leakage current per I/O pin over recommended operating conditions $V_{IH} < V_{IN} < V_{CCI}$. Input current is larger when operating outside recommended ranges
3. Currents are measured at 100°C junction temperature and maximum voltage.
4. Currents are measured at 85°C junction temperature.
5. Software default selection highlighted in gray.

Timing Characteristics

1.5 V DC Core Voltage

Table 2-159 • Output Data Register Propagation Delays
Commercial-Case Conditions: T_J = 70°C, Worst-Case VCC = 1.425 V

Parameter	Description	Std.	Units
t _{CLKQ}	Clock-to-Q of the Output Data Register	1.00	ns
t _{OSUD}	Data Setup Time for the Output Data Register	0.51	ns
t _{OHD}	Data Hold Time for the Output Data Register	0.00	ns
t _{OSUE}	Enable Setup Time for the Output Data Register	0.70	ns
t _{OHE}	Enable Hold Time for the Output Data Register	0.00	ns
t _{OCLR2Q}	Asynchronous Clear-to-Q of the Output Data Register	1.34	ns
t _{OPRE2Q}	Asynchronous Preset-to-Q of the Output Data Register	1.34	ns
t _{OREMCLR}	Asynchronous Clear Removal Time for the Output Data Register	0.00	ns
t _{ORECCLR}	Asynchronous Clear Recovery Time for the Output Data Register	0.24	ns
t _{OREMPRE}	Asynchronous Preset Removal Time for the Output Data Register	0.00	ns
t _{ORECPRE}	Asynchronous Preset Recovery Time for the Output Data Register	0.24	ns
t _{OWCLR}	Asynchronous Clear Minimum Pulse Width for the Output Data Register	0.19	ns
t _{OWPRE}	Asynchronous Preset Minimum Pulse Width for the Output Data Register	0.19	ns
t _{OCKMPWH}	Clock Minimum Pulse Width High for the Output Data Register	0.31	ns
t _{OCKMPWL}	Clock Minimum Pulse Width Low for the Output Data Register	0.28	ns

Note: For specific junction temperature and voltage supply levels, refer to Table 2-6 on page 2-7 for derating values.

1.2 V DC Core Voltage

Table 2-160 • Output Data Register Propagation Delays
Commercial-Case Conditions: T_J = 70°C, Worst-Case VCC = 1.14 V

Parameter	Description	Std.	Units
t _{CLKQ}	Clock-to-Q of the Output Data Register	1.52	ns
t _{OSUD}	Data Setup Time for the Output Data Register	1.15	ns
t _{OHD}	Data Hold Time for the Output Data Register	0.00	ns
t _{OSUE}	Enable Setup Time for the Output Data Register	1.11	ns
t _{OHE}	Enable Hold Time for the Output Data Register	0.00	ns
t _{OCLR2Q}	Asynchronous Clear-to-Q of the Output Data Register	1.96	ns
t _{OPRE2Q}	Asynchronous Preset-to-Q of the Output Data Register	1.96	ns
t _{OREMCLR}	Asynchronous Clear Removal Time for the Output Data Register	0.00	ns
t _{ORECCLR}	Asynchronous Clear Recovery Time for the Output Data Register	0.24	ns
t _{OREMPRE}	Asynchronous Preset Removal Time for the Output Data Register	0.00	ns
t _{ORECPRE}	Asynchronous Preset Recovery Time for the Output Data Register	0.24	ns
t _{OWCLR}	Asynchronous Clear Minimum Pulse Width for the Output Data Register	0.19	ns
t _{OWPRE}	Asynchronous Preset Minimum Pulse Width for the Output Data Register	0.19	ns
t _{OCKMPWH}	Clock Minimum Pulse Width High for the Output Data Register	0.31	ns
t _{OCKMPWL}	Clock Minimum Pulse Width Low for the Output Data Register	0.28	ns

Note: For specific junction temperature and voltage supply levels, refer to Table 2-7 on page 2-7 for derating values.

VersaTile Characteristics

VersaTile Specifications as a Combinatorial Module

The IGLOO library offers all combinations of LUT-3 combinatorial functions. In this section, timing characteristics are presented for a sample of the library. For more details, refer to the *IGLOO, Fusion, and ProASIC3 Macro Library Guide*.

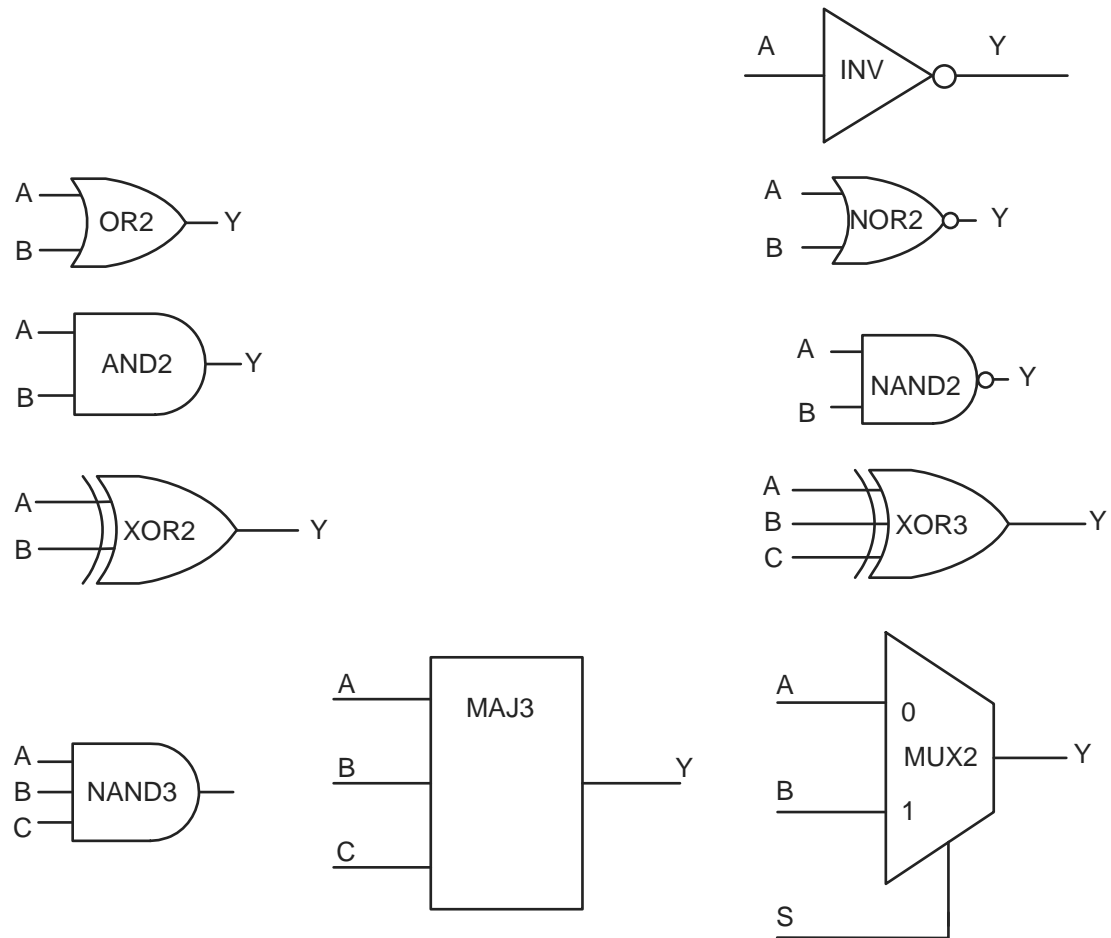

Figure 2-25 • Sample of Combinatorial Cells

Global Tree Timing Characteristics

Global clock delays include the central rib delay, the spine delay, and the row delay. Delays do not include I/O input buffer clock delays, as these are I/O standard-dependent, and the clock may be driven and conditioned internally by the CCC module. For more details on clock conditioning capabilities, refer to the "Clock Conditioning Circuits" section on page 2-115. Table 2-173 to Table 2-188 on page 2-114 present minimum and maximum global clock delays within each device. Minimum and maximum delays are measured with minimum and maximum loading.

Timing Characteristics

1.5 V DC Core Voltage

Table 2-173 • AGL015 Global Resource
Commercial-Case Conditions: $T_J = 70^\circ\text{C}$, $V_{CC} = 1.425\text{ V}$

Parameter	Description	Std.		Units
		Min. ¹	Max. ²	
t _{RCKL}	Input Low Delay for Global Clock	1.21	1.42	ns
t _{RCKH}	Input High Delay for Global Clock	1.23	1.49	ns
t _{RCKMPWH}	Minimum Pulse Width High for Global Clock	1.18		ns
t _{RCKMPWL}	Minimum Pulse Width Low for Global Clock	1.15		ns
t _{RCKSW}	Maximum Skew for Global Clock		0.27	ns

Notes:

1. Value reflects minimum load. The delay is measured from the CCC output to the clock pin of a sequential element, located in a lightly loaded row (single element is connected to the global net).
2. Value reflects maximum load. The delay is measured on the clock pin of the farthest sequential element, located in a fully loaded row (all available flip-flops are connected to the global net in the row).
3. For specific junction temperature and voltage supply levels, refer to Table 2-6 on page 2-7 for derating values.

Table 2-174 • AGL030 Global Resource
Commercial-Case Conditions: $T_J = 70^\circ\text{C}$, $V_{CC} = 1.425\text{ V}$

Parameter	Description	Std.		Units
		Min. ¹	Max. ²	
t _{RCKL}	Input Low Delay for Global Clock	1.21	1.42	ns
t _{RCKH}	Input High Delay for Global Clock	1.23	1.49	ns
t _{RCKMPWH}	Minimum Pulse Width High for Global Clock	1.18		ns
t _{RCKMPWL}	Minimum Pulse Width Low for Global Clock	1.15		ns
t _{RCKSW}	Maximum Skew for Global Clock		0.27	ns

Notes:

1. Value reflects minimum load. The delay is measured from the CCC output to the clock pin of a sequential element, located in a lightly loaded row (single element is connected to the global net).
2. Value reflects maximum load. The delay is measured on the clock pin of the farthest sequential element, located in a fully loaded row (all available flip-flops are connected to the global net in the row).
3. For specific junction temperature and voltage supply levels, refer to Table 2-6 on page 2-7 for derating values.

1.2 V DC Core Voltage

Table 2-193 • RAM4K9

Commercial-Case Conditions: $T_J = 70^\circ\text{C}$, Worst-Case $V_{CC} = 1.14\text{ V}$

Parameter	Description	Std.	Units
t_{AS}	Address setup time	1.53	ns
t_{AH}	Address hold time	0.29	ns
t_{ENS}	REN WEN setup time	1.50	ns
t_{ENH}	REN, WEN hold time	0.29	ns
t_{BKS}	BLK setup time	3.05	ns
t_{BKH}	BLK hold time	0.29	ns
t_{DS}	Input data (DIN) setup time	1.33	ns
t_{DH}	Input data (DIN) hold time	0.66	ns
t_{CKQ1}	Clock High to new data valid on DOUT (output retained, WMODE = 0)	6.61	ns
	Clock High to new data valid on DOUT (flow-through, WMODE = 1)	5.72	ns
t_{CKQ2}	Clock High to new data valid on DOUT (pipelined)	3.38	ns
t_{C2CWLL}^1	Address collision clk-to-clk delay for reliable write after write on same address – Applicable to Closing Edge	0.30	ns
t_{C2CRWH}^1	Address collision clk-to-clk delay for reliable read access after write on same address – Applicable to Opening Edge	0.89	ns
t_{C2CWRH}^1	Address collision clk-to-clk delay for reliable write access after read on same address – Applicable to Opening Edge	1.01	ns
t_{RSTBQ}	RESET Low to data out Low on DOUT (flow-through)	3.86	ns
	RESET Low to data out Low on DOUT (pipelined)	3.86	ns
$t_{REMRSTB}$	RESET removal	1.12	ns
$t_{RECRSTB}$	RESET recovery	5.93	ns
$t_{MPWRSTB}$	RESET minimum pulse width	1.18	ns
t_{CYC}	Clock cycle time	10.90	ns
F_{MAX}	Maximum frequency	92	MHz

Notes:

1. For more information, refer to the application note Simultaneous Read-Write Operations in Dual-Port SRAM for Flash-Based cSoCs and FPGAs.
2. For specific junction temperature and voltage supply levels, refer to Table 2-6 on page 2-7 for derating values.

Table 2-194 • RAM512X18
Commercial-Case Conditions: T_J = 70°C, Worst-Case VCC = 1.14 V

Parameter	Description	Std.	Units
t _{AS}	Address setup time	1.53	ns
t _{AH}	Address hold time	0.29	ns
t _{ENS}	REN, WEN setup time	1.36	ns
t _{ENH}	REN, WEN hold time	0.15	ns
t _{DS}	Input data (WD) setup time	1.33	ns
t _{DH}	Input data (WD) hold time	0.66	ns
t _{CKQ1}	Clock High to new data valid on RD (output retained)	7.88	ns
t _{CKQ2}	Clock High to new data valid on RD (pipelined)	3.20	ns
t _{C2CRWH} ¹	Address collision clk-to-clk delay for reliable read access after write on same address – Applicable to Opening Edge	0.87	ns
t _{C2CWRH} ¹	Address collision clk-to-clk delay for reliable write access after read on same address – Applicable to Opening Edge	1.04	ns
t _{RSTBQ}	RESET Low to data out Low on RD (flow through)	3.86	ns
	RESET Low to data out Low on RD (pipelined)	3.86	ns
t _{REMRSTB}	RESET removal	1.12	ns
t _{RECRSTB}	RESET recovery	5.93	ns
t _{MPWRSTB}	RESET minimum pulse width	1.18	ns
t _{CYC}	Clock cycle time	10.90	ns
F _{MAX}	Maximum frequency	92	MHz

Notes:

1. For more information, refer to the application note Simultaneous Read-Write Operations in Dual-Port SRAM for Flash-Based cSoCs and FPGAs.
2. For specific junction temperature and voltage supply levels, refer to Table 2-6 on page 2-7 for derating values.

CS81	
Pin Number	AGL250 Function
A1	GAA0/IO00RSB0
A2	GAA1/IO01RSB0
A3	GAC0/IO04RSB0
A4	IO13RSB0
A5	IO21RSB0
A6	IO27RSB0
A7	GBB0/IO37RSB0
A8	GBA1/IO40RSB0
A9	GBA2/IO41PPB1
B1	GAA2/IO118UPB3
B2	GAB0/IO02RSB0
B3	GAC1/IO05RSB0
B4	IO11RSB0
B5	IO23RSB0
B6	GBC0/IO35RSB0
B7	GBB1/IO38RSB0
B8	IO41NPB1
B9	GBB2/IO42PSB1
C1	GAB2/IO117UPB3
C2	IO118VPB3
C3	GND
C4	IO15RSB0
C5	IO25RSB0
C6	GND
C7	GBA0/IO39RSB0
C8	GBC2/IO43PDB1
C9	IO43NDB1
D1	GAC2/IO116USB3
D2	IO117VPB3
D3	GFA2/IO107PSB3
D4	VCC
D5	VCCIB0
D6	GND
D7	IO52NPB1
D8	GCC1/IO48PDB1
D9	GCC0/IO48NDB1

CS81	
Pin Number	AGL250 Function
E1	GFB0/IO109NDB3
E2	GFB1/IO109PDB3
E3	GFA1/IO108PSB3
E4	VCCIB3
E5	VCC
E6	VCCIB1
E7	GCA0/IO50NDB1
E8	GCA1/IO50PDB1
E9	GCB2/IO52PPB1
F1	VCCPLF
F2	VCOMPLF
F3	GND
F4	GND
F5	VCCIB2
F6	GND
F7	GDA1/IO60USB1
F8	GDC1/IO58UDB1
F9	GDC0/IO58VDB1
G1	GEA0/IO98NDB3
G2	GEC1/IO100PDB3
G3	GEC0/IO100NDB3
G4	IO91RSB2
G5	IO86RSB2
G6	IO71RSB2
G7	GDB2/IO62RSB2
G8	VJTAG
G9	TRST
H1	GEA1/IO98PDB3
H2	FF/GEB2/IO96RSB2
H3	IO93RSB2
H4	IO90RSB2
H5	IO85RSB2
H6	IO77RSB2
H7	GDA2/IO61RSB2
H8	TDI
H9	TDO

CS81	
Pin Number	AGL250 Function
J1	GEA2/IO97RSB2
J2	GEC2/IO95RSB2
J3	IO92RSB2
J4	IO88RSB2
J5	IO84RSB2
J6	IO74RSB2
J7	TCK
J8	TMS
J9	VPUMP

CS121	
Pin Number	AGL060 Function
K10	VPUMP
K11	GDB1/IO47RSB0
L1	VMV1
L2	GNDQ
L3	IO65RSB1
L4	IO63RSB1
L5	IO61RSB1
L6	IO58RSB1
L7	IO57RSB1
L8	IO55RSB1
L9	GNDQ
L10	GDA0/IO50RSB0
L11	VMV1

CS196

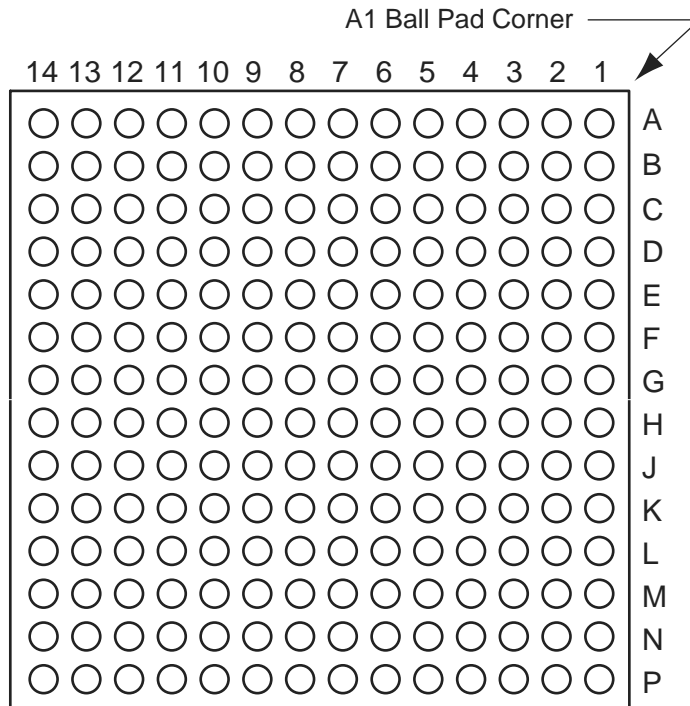

Note: This is the bottom view of the package.

Note

For more information on package drawings, see *PD3068: Package Mechanical Drawings*.

CS196	
Pin Number	AGL125 Function
H11	GCB0/IO54RSB0
H12	GCA1/IO55RSB0
H13	IO49RSB0
H14	GCA2/IO57RSB0
J1	GFC2/IO115RSB1
J2	IO110RSB1
J3	IO94RSB1
J4	IO93RSB1
J5	IO89RSB1
J6	NC
J7	VCC
J8	VCC
J9	NC
J10	IO60RSB0
J11	GCB2/IO58RSB0
J12	IO50RSB0
J13	GDC1/IO61RSB0
J14	GDC0/IO62RSB0
K1	IO99RSB1
K2	GND
K3	IO95RSB1
K4	VCCIB1
K5	NC
K6	IO86RSB1
K7	IO80RSB1
K8	IO74RSB1
K9	IO72RSB1
K10	NC
K11	VCCIB0
K12	GDA1/IO65RSB0
K13	GND
K14	GDB1/IO63RSB0
L1	GEB1/IO107RSB1
L2	GEC1/IO109RSB1
L3	GEC0/IO108RSB1
L4	IO96RSB1

CS196	
Pin Number	AGL125 Function
L5	IO91RSB1
L6	IO90RSB1
L7	IO83RSB1
L8	IO81RSB1
L9	IO71RSB1
L10	IO70RSB1
L11	VPUMP
L12	VJTAG
L13	GDA0/IO66RSB0
L14	GDB0/IO64RSB0
M1	GEB0/IO106RSB1
M2	GEA1/IO105RSB1
M3	GNDQ
M4	VCCIB1
M5	IO92RSB1
M6	IO88RSB1
M7	NC
M8	VCCIB1
M9	IO76RSB1
M10	GDB2/IO68RSB1
M11	VCCIB1
M12	VMV1
M13	TRST
M14	VCCIB0
N1	GEA0/IO104RSB1
N2	VMV1
N3	GEC2/IO101RSB1
N4	IO100RSB1
N5	GND
N6	IO87RSB1
N7	IO82RSB1
N8	IO78RSB1
N9	IO73RSB1
N10	GND
N11	TCK
N12	TDI

CS196	
Pin Number	AGL125 Function
N13	GNDQ
N14	TDO
P1	GND
P2	GEA2/IO103RSB1
P3	FF/GEB2/IO102RSB1
P4	IO98RSB1
P5	IO97RSB1
P6	IO85RSB1
P7	IO84RSB1
P8	IO79RSB1
P9	IO77RSB1
P10	IO75RSB1
P11	GDC2/IO69RSB1
P12	GDA2/IO67RSB1
P13	TMS
P14	GND

CS281	
Pin Number	AGL1000 Function
H8	VCC
H9	VCCIB0
H10	VCC
H11	VCCIB0
H12	VCC
H13	VCCIB1
H15	IO90NPB1
H16	GCB0/IO92NPB1
H18	GCA1/IO93PPB1
H19	GCA2/IO94PPB1
J1	VCOMPLF
J2	GFA0/IO207NDB3
J4	VCCPLF
J5	GFC0/IO209NPB3
J7	GFA2/IO206PDB3
J8	VCCIB3
J9	GND
J10	GND
J11	GND
J12	VCCIB1
J13	GCC1/IO91PPB1
J15	GCA0/IO93NPB1
J16	GCB2/IO95PPB1
J18	IO94NPB1
J19	IO102PSB1
K1	VCCIB3
K2	GFA1/IO207PDB3
K4	GND
K5	IO204NPB3
K7	IO206NDB3
K8	VCC
K9	GND
K10	GND
K11	GND
K12	VCC
K13	GCC2/IO96PPB1

CS281	
Pin Number	AGL1000 Function
K15	IO95NPB1
K16	GND
K18	IO96NPB1
K19	VCCIB1
L1	GFB2/IO205PDB3
L2	IO205NDB3
L4	GFC2/IO204PPB3
L5	IO203PPB3
L7	IO203NPB3
L8	VCCIB3
L9	GND
L10	GND
L11	GND
L12	VCCIB1
L13	IO103PPB1
L15	IO103NPB1
L16	IO97PPB1
L18	IO98NPB1
L19	IO97NPB1
M1	IO202PDB3
M2	IO202NDB3
M4	IO201NPB3
M5	IO198PPB3
M7	VCCIB3
M8	VCC
M9	VCCIB2
M10	VCC
M11	VCCIB2
M12	VCC
M13	VCCIB1
M15	IO104NPB1
M16	IO100NPB1
M18	IO104PPB1
M19	IO98PPB1
N1	IO201PPB3
N2	IO198NPB3

CS281	
Pin Number	AGL1000 Function
N4	IO196PPB3
N5	IO197NPB3
N7	GEA2/IO187RSB2
N8	VCCIB2
N9	IO155RSB2
N10	IO154RSB2
N11	IO150RSB2
N12	VCCIB2
N13	VPUMP
N15	IO107PPB1
N16	IO105PPB1
N18	IO107NPB1
N19	IO100PPB1
P1	IO195PDB3
P2	GND
P3	IO195NDB3
P4	IO194PPB3
P5	GEA0/IO188NPB3
P15	IO108NDB1
P16	IO108PDB1
P17	GDC1/IO111PPB1
P18	GND
P19	IO105NPB1
R1	IO196NPB3
R2	IO194NPB3
R4	GEC1/IO190PPB3
R5	GEB1/IO189PPB3
R6	IO184RSB2
R7	IO173RSB2
R8	IO168RSB2
R9	IO160RSB2
R10	IO151RSB2
R11	IO141RSB2
R12	IO136RSB2
R13	IO127RSB2
R14	IO124RSB2

QN68	
Pin Number	AGL030 Function
1	IO82RSB1
2	IO80RSB1
3	IO78RSB1
4	IO76RSB1
5	GEC0/IO73RSB1
6	GEA0/IO72RSB1
7	GEB0/IO71RSB1
8	VCC
9	GND
10	VCCIB1
11	IO68RSB1
12	IO67RSB1
13	IO66RSB1
14	IO65RSB1
15	IO64RSB1
16	IO63RSB1
17	IO62RSB1
18	FF/IO60RSB1
19	IO58RSB1
20	IO56RSB1
21	IO54RSB1
22	IO52RSB1
23	IO51RSB1
24	VCC
25	GND
26	VCCIB1
27	IO50RSB1
28	IO48RSB1
29	IO46RSB1
30	IO44RSB1
31	IO42RSB1
32	TCK
33	TDI
34	TMS
35	VPUMP
36	TDO

QN68	
Pin Number	AGL030 Function
37	TRST
38	VJTAG
39	IO40RSB0
40	IO37RSB0
41	GDB0/IO34RSB0
42	GDA0/IO33RSB0
43	GDC0/IO32RSB0
44	VCCIB0
45	GND
46	VCC
47	IO31RSB0
48	IO29RSB0
49	IO28RSB0
50	IO27RSB0
51	IO25RSB0
52	IO24RSB0
53	IO22RSB0
54	IO21RSB0
55	IO19RSB0
56	IO17RSB0
57	IO15RSB0
58	IO14RSB0
59	VCCIB0
60	GND
61	VCC
62	IO12RSB0
63	IO10RSB0
64	IO08RSB0
65	IO06RSB0
66	IO04RSB0
67	IO02RSB0
68	IO00RSB0

FG256	
Pin Number	AGL400 Function
H3	GFB1/IO146PPB3
H4	VCOMPLF
H5	GFC0/IO147NPB3
H6	VCC
H7	GND
H8	GND
H9	GND
H10	GND
H11	VCC
H12	GCC0/IO67NPB1
H13	GCB1/IO68PPB1
H14	GCA0/IO69NPB1
H15	NC
H16	GCB0/IO68NPB1
J1	GFA2/IO144PPB3
J2	GFA1/IO145PDB3
J3	VCCPLF
J4	IO143NDB3
J5	GFB2/IO143PDB3
J6	VCC
J7	GND
J8	GND
J9	GND
J10	GND
J11	VCC
J12	GCB2/IO71PPB1
J13	GCA1/IO69PPB1
J14	GCC2/IO72PPB1
J15	NC
J16	GCA2/IO70PDB1
K1	GFC2/IO142PDB3
K2	IO144NPB3
K3	IO141PPB3
K4	IO120RSB2
K5	VCCIB3
K6	VCC
K7	GND
K8	GND

FG256	
Pin Number	AGL400 Function
K9	GND
K10	GND
K11	VCC
K12	VCCIB1
K13	IO71NPB1
K14	IO74RSB1
K15	IO72NPB1
K16	IO70NDB1
L1	IO142NDB3
L2	IO141NPB3
L3	IO125RSB2
L4	IO139RSB3
L5	VCCIB3
L6	GND
L7	VCC
L8	VCC
L9	VCC
L10	VCC
L11	GND
L12	VCCIB1
L13	GDB0/IO78VPB1
L14	IO76VDB1
L15	IO76UDB1
L16	IO75PDB1
M1	IO140PDB3
M2	IO130RSB2
M3	IO138NPB3
M4	GEC0/IO137NPB3
M5	VMV3
M6	VCCIB2
M7	VCCIB2
M8	IO108RSB2
M9	IO101RSB2
M10	VCCIB2
M11	VCCIB2
M12	VMV2
M13	IO83RSB2
M14	GDB1/IO78UPB1

FG256	
Pin Number	AGL400 Function
M15	GDC1/IO77UDB1
M16	IO75NDB1
N1	IO140NDB3
N2	IO138PPB3
N3	GEC1/IO137PPB3
N4	IO131RSB2
N5	GNDQ
N6	GEA2/IO134RSB2
N7	IO117RSB2
N8	IO111RSB2
N9	IO99RSB2
N10	IO94RSB2
N11	IO87RSB2
N12	GNDQ
N13	IO93RSB2
N14	VJTAG
N15	GDC0/IO77VDB1
N16	GDA1/IO79UDB1
P1	GEB1/IO136PDB3
P2	GEB0/IO136NDB3
P3	VMV2
P4	IO129RSB2
P5	IO128RSB2
P6	IO122RSB2
P7	IO115RSB2
P8	IO110RSB2
P9	IO98RSB2
P10	IO95RSB2
P11	IO88RSB2
P12	IO84RSB2
P13	TCK
P14	VPUMP
P15	TRST
P16	GDA0/IO79VDB1
R1	GEA1/IO135PDB3
R2	GEA0/IO135NDB3
R3	IO127RSB2
R4	GEC2/IO132RSB2

FG256	
Pin Number	AGL1000 Function
A1	GND
A2	GAA0/IO00RSB0
A3	GAA1/IO01RSB0
A4	GAB0/IO02RSB0
A5	IO16RSB0
A6	IO22RSB0
A7	IO28RSB0
A8	IO35RSB0
A9	IO45RSB0
A10	IO50RSB0
A11	IO55RSB0
A12	IO61RSB0
A13	GBB1/IO75RSB0
A14	GBA0/IO76RSB0
A15	GBA1/IO77RSB0
A16	GND
B1	GAB2/IO224PDB3
B2	GAA2/IO225PDB3
B3	GNDQ
B4	GAB1/IO03RSB0
B5	IO17RSB0
B6	IO21RSB0
B7	IO27RSB0
B8	IO34RSB0
B9	IO44RSB0
B10	IO51RSB0
B11	IO57RSB0
B12	GBC1/IO73RSB0
B13	GBB0/IO74RSB0
B14	IO71RSB0
B15	GBA2/IO78PDB1
B16	IO81PDB1
C1	IO224NDB3
C2	IO225NDB3
C3	VMV3
C4	IO11RSB0
C5	GAC0/IO04RSB0
C6	GAC1/IO05RSB0

FG256	
Pin Number	AGL1000 Function
C7	IO25RSB0
C8	IO36RSB0
C9	IO42RSB0
C10	IO49RSB0
C11	IO56RSB0
C12	GBC0/IO72RSB0
C13	IO62RSB0
C14	VMV0
C15	IO78NDB1
C16	IO81NDB1
D1	IO222NDB3
D2	IO222PDB3
D3	GAC2/IO223PDB3
D4	IO223NDB3
D5	GNDQ
D6	IO23RSB0
D7	IO29RSB0
D8	IO33RSB0
D9	IO46RSB0
D10	IO52RSB0
D11	IO60RSB0
D12	GNDQ
D13	IO80NDB1
D14	GBB2/IO79PDB1
D15	IO79NDB1
D16	IO82NSB1
E1	IO217PDB3
E2	IO218PDB3
E3	IO221NDB3
E4	IO221PDB3
E5	VMV0
E6	VCCIB0
E7	VCCIB0
E8	IO38RSB0
E9	IO47RSB0
E10	VCCIB0
E11	VCCIB0
E12	VMV1

FG256	
Pin Number	AGL1000 Function
E13	GBC2/IO80PDB1
E14	IO83PPB1
E15	IO86PPB1
E16	IO87PDB1
F1	IO217NDB3
F2	IO218NDB3
F3	IO216PDB3
F4	IO216NDB3
F5	VCCIB3
F6	GND
F7	VCC
F8	VCC
F9	VCC
F10	VCC
F11	GND
F12	VCCIB1
F13	IO83NPB1
F14	IO86NPB1
F15	IO90PPB1
F16	IO87NDB1
G1	IO210PSB3
G2	IO213NDB3
G3	IO213PDB3
G4	GFC1/IO209PPB3
G5	VCCIB3
G6	VCC
G7	GND
G8	GND
G9	GND
G10	GND
G11	VCC
G12	VCCIB1
G13	GCC1/IO91PPB1
G14	IO90NPB1
G15	IO88PDB1
G16	IO88NDB1
H1	GFB0/IO208NPB3
H2	GFA0/IO207NDB3

FG484	
Pin Number	AGL1000 Function
U1	IO195PDB3
U2	IO195NDB3
U3	IO194NPB3
U4	GEB1/IO189PDB3
U5	GEB0/IO189NDB3
U6	VMV2
U7	IO179RSB2
U8	IO171RSB2
U9	IO165RSB2
U10	IO159RSB2
U11	IO151RSB2
U12	IO137RSB2
U13	IO134RSB2
U14	IO128RSB2
U15	VMV1
U16	TCK
U17	VPUMP
U18	TRST
U19	GDA0/IO113NDB1
U20	NC
U21	IO108NDB1
U22	IO109PDB1
V1	NC
V2	NC
V3	GND
V4	GEA1/IO188PDB3
V5	GEA0/IO188NDB3
V6	IO184RSB2
V7	GEC2/IO185RSB2
V8	IO168RSB2
V9	IO163RSB2
V10	IO157RSB2
V11	IO149RSB2
V12	IO143RSB2
V13	IO138RSB2
V14	IO131RSB2

5 – Datasheet Information

List of Changes

The following tables list critical changes that were made in each revision of the IGLOO datasheet.

Revision	Changes	Page
Revision 27 (May 2016)	Added the deleted package FG144 from AGL125 device in "IGLOO Devices" (SAR 79355).	1-1
Revision 26 (March 2016)	Updated "IGLOO Ordering Information" and "Temperature Grade Offerings" notes by: <ul style="list-style-type: none"> Replacing Commercial (0°C to +70°C Ambient Temperature) with Commercial (0°C to +85°C Junction Temperature) (SAR 48352). Replacing Industrial (-40°C to +85°C Ambient Temperature) with Industrial (-40°C to +100°C Junction Temperature) (SAR 48352). 	1-III and 1-IV
	Ambient temperature row removed in Table 2-2 (SAR 48352).	2-2
	Updated Table 2-2 note 2 from "To ensure targeted reliability standards are met across ambient and junction operating temperatures, Microsemi recommends that the user follow best design practices using Microsemi's timing and power simulation tools." to "Software Default Junction Temperature Range in the Libero SoC software is set to 0°C to +70°C for commercial, and -40°C to +85°C for industrial. To ensure targeted reliability standards are met across the full range of junction temperatures, Microsemi recommends using custom settings for temperature range before running timing and power analysis tools. For more information on custom settings, refer to the New Project Dialog Box in the Libero SoC Online Help." (SAR 77087).	2-2
	Updated Table 2-2 note 9 from "VMV pins must be connected to the corresponding VCCI pins. See the "Pin Descriptions" chapter of the IGLOO FPGA Fabric User Guide for further information." to "VMV and VCCI must be at the same voltage within a given I/O bank. VMV pins must be connected to the corresponding VCCI pins. See the "VMVx I/O Supply Voltage (quiet)" on page 3-1 for further information." (SAR 77087)	2-2
	Added 2 mA drive strengths in tables same as 4 mA (SAR 57179).	NA
	Added reference of Package Mechanical Drawings document in all package pin assignment notes (76777).	NA
Revision 25 (June 2015)	Removed package FG144 from AGL060 device in the following tables: "IGLOO Devices", "I/Os Per Package1" and "Temperature Grade Offerings" (SAR 68517)	I, II, and IV
	Removed Package Pin Assignment table of AGL060 device from FG144.(SAR 68517)	-
Revision 24 (March 2014)	Note added for the discontinuance of QN132 package to the following tables: "IGLOO Devices", "I/Os Per Package1", "IGLOO FPGAs Package Sizes Dimensions", and "Temperature Grade Offerings" and "QN132" section (SAR 55117, PDN 1306).	I, II, IV, and 4-28
	Removed packages CS81 and QN132 from AGL250 device in the following tables: "IGLOO Devices", "I/Os Per Package1", and "Temperature Grade Offerings" (SAR 49472).	I, II, and IV

