



Welcome to [E-XFL.COM](http://E-XFL.COM)

**What is "[Embedded - Microcontrollers](#)"?**

"[Embedded - Microcontrollers](#)" refer to small, integrated circuits designed to perform specific tasks within larger systems. These microcontrollers are essentially compact computers on a single chip, containing a processor core, memory, and programmable input/output peripherals. They are called "embedded" because they are embedded within electronic devices to control various functions, rather than serving as standalone computers. Microcontrollers are crucial in modern electronics, providing the intelligence and control needed for a wide range of applications.

**Applications of "[Embedded - Microcontrollers](#)"**

**Details**

Product Status	Active
Core Processor	ARM® Cortex®-M4F
Core Size	32-Bit Single-Core
Speed	96MHz
Connectivity	1-Wire, I <sup>2</sup> C, SPI, UART/USART, USB
Peripherals	Brown-out Detect/Reset, POR, PWM, TPU, WDT
Number of I/O	66
Program Memory Size	2MB (2M x 8)
Program Memory Type	FLASH
EEPROM Size	-
RAM Size	512K x 8
Voltage - Supply (Vcc/Vdd)	1.14V ~ 3.6V
Data Converters	A/D 4x10b
Oscillator Type	Internal
Operating Temperature	-20°C ~ 85°C (TA)
Mounting Type	Surface Mount
Package / Case	100-WFBGA, WLPGA
Supplier Device Package	100-WLP (4.4x4.4)
Purchase URL	<a href="https://www.e-xfl.com/product-detail/analog-devices/max32631iwg-t">https://www.e-xfl.com/product-detail/analog-devices/max32631iwg-t</a>

Simplified Block Diagram

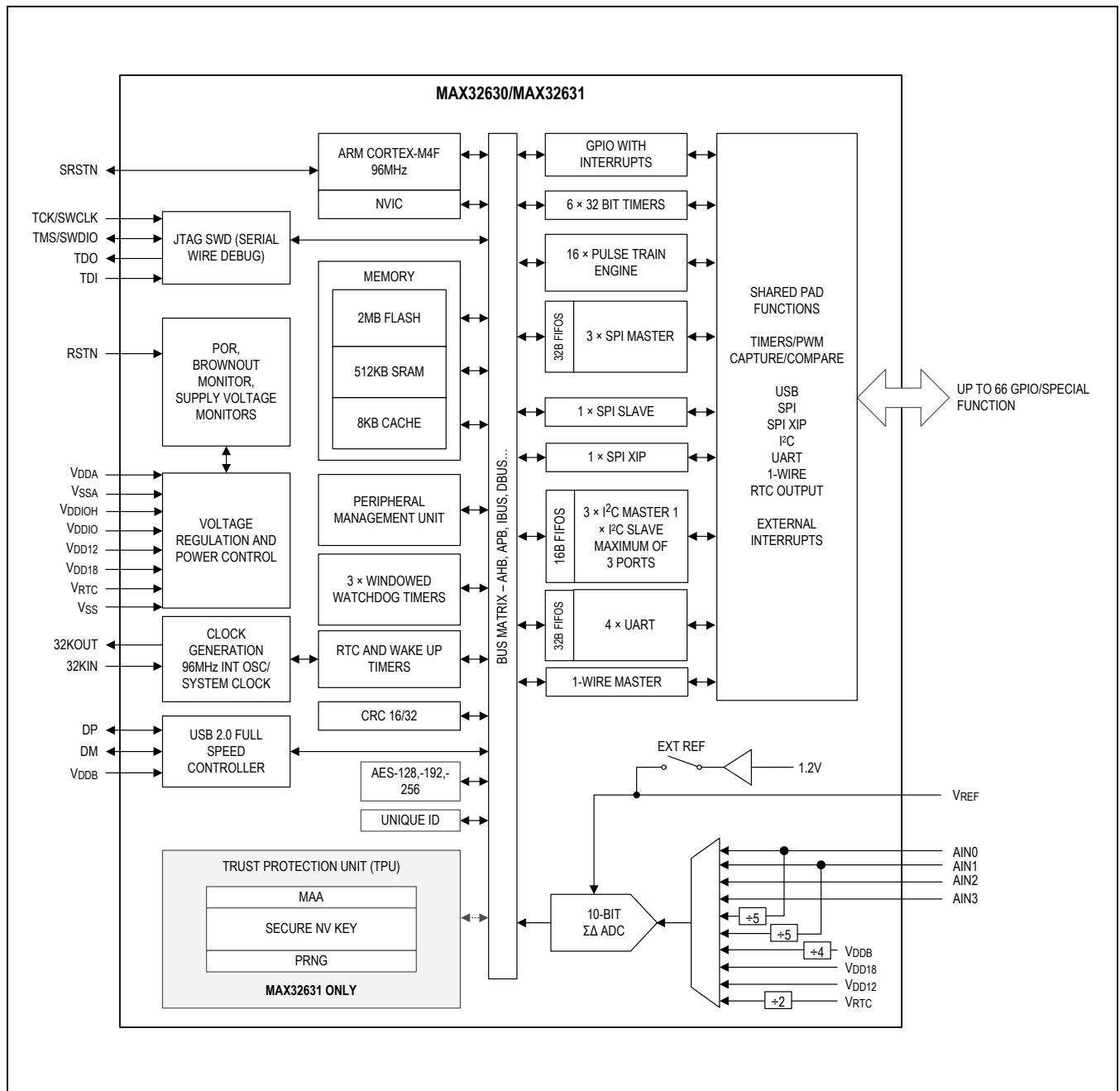

## Electrical Characteristics

(Limits are 100% tested at  $T_A = +25^\circ\text{C}$  and  $T_A = +85^\circ\text{C}$ . Limits over the operating temperature range and relevant supply voltage range are guaranteed by design and characterization. Specifications marked GBD are guaranteed by design and not production tested. Specifications to  $-20^\circ\text{C}$  are guaranteed by design and are not production tested.)

PARAMETER	SYMBOL	CONDITIONS	MIN	TYP	MAX	UNITS
Supply Voltage	$V_{DD18}$		1.71	1.8	1.89	V
	$V_{DD12}$		1.14	1.2	1.26	
	$V_{DDA}$		1.71	1.8	1.89	
	$V_{RTC}$		1.75	1.8	1.89	
	$V_{DDIO}$		1.71	1.8	3.6	
	$V_{DDIOH}$	$V_{DDIOH}$ must be $\geq V_{DDIO}$	1.71	1.8	3.6	
Power Fail Reset Voltage	$V_{RST}$	Monitors $V_{DD18}$	1.62		1.7	V
Power-On Reset Voltage	$V_{POR}$	Monitors $V_{DD18}$		1.5		V
RAM Data Retention Voltage	$V_{DRV}$			0.93		V
$V_{DD12}$ Dynamic Current, LP3 Mode	$I_{DD12\_DLP3}$	Measured on the $V_{DD12}$ pin and executing code from cache memory, all inputs are tied to $V_{SS}$ or $V_{DD18}$ , outputs do not source/sink any current, PMU disabled		106		$\mu\text{A}/\text{MHz}$
$V_{DD12}$ Fixed Current, LP3 Mode	$I_{DD12\_FLP3}$	Measured on the $V_{DD12}$ pin and executing code from cache memory, all inputs are tied to $V_{SS}$ or $V_{DD18}$ , outputs do not source/sink any current, 96MHz oscillator selected as system clock		173		$\mu\text{A}$
		Measured on the $V_{DD12}$ pin and executing code from cache memory, all inputs are tied to $V_{SS}$ or $V_{DD18}$ , outputs do not source/sink any current, 4MHz oscillator selected as system clock		72		
$V_{DD18}$ Fixed Current, LP3 Mode	$I_{DD18\_FLP3}$	Measured on the $V_{DD18} + V_{DDA}$ device pins and executing code from cache memory, all inputs are tied to $V_{SS}$ or $V_{DD18}$ , outputs do not source/sink any current, 96MHz oscillator selected as system clock		366		$\mu\text{A}$
		Measured on the $V_{DD18} + V_{DDA}$ device pins and executing code from cache memory, all inputs are tied to $V_{SS}$ or $V_{DD18}$ , outputs do not source/sink any current, 4MHz oscillator selected as system clock		33		
$V_{DD12}$ Dynamic Current, LP2 Mode	$I_{DD12\_DLP2}$	Measured on the $V_{DD12}$ pin, ARM in sleep mode, PMU with two channels active		27		$\mu\text{A}/\text{MHz}$

**Electrical Characteristics (continued)**

(Limits are 100% tested at  $T_A = +25^\circ\text{C}$  and  $T_A = +85^\circ\text{C}$ . Limits over the operating temperature range and relevant supply voltage range are guaranteed by design and characterization. Specifications marked GBD are guaranteed by design and not production tested. Specifications to  $-20^\circ\text{C}$  are guaranteed by design and are not production tested.)

PARAMETER	SYMBOL	CONDITIONS	MIN	TYP	MAX	UNITS
V <sub>DD12</sub> Fixed Current, LP2 Mode	I <sub>DD12_FLP2</sub>	Measured on the V <sub>DD12</sub> pin, ARM in sleep mode, PMU with two channels active, 96MHz oscillator selected as system clock		173		μA
		Measured on the V <sub>DD12</sub> pin, ARM in sleep mode, PMU with two channels active, 4MHz oscillator selected as system clock		72		
V <sub>DD18</sub> Fixed Current, LP2 Mode	I <sub>DD18_FLP2</sub>	Measured on the V <sub>DD18</sub> + V <sub>DDA</sub> device pins, ARM in sleep mode, PMU with two channels active, 96MHz oscillator selected as system clock		366		μA
		Measured on the V <sub>DD18</sub> + V <sub>DDA</sub> device pins, ARM in sleep mode, PMU with two channels active, 4MHz oscillator selected as system clock		33		
V <sub>DD12</sub> Fixed Current, LP1 Mode	I <sub>DD12_FLP1</sub>	Standby state with full data retention		1.86		μA
V <sub>DD18</sub> Fixed Current, LP1 Mode	I <sub>DD18_FLP1</sub>	Standby state with full data retention		120		nA
V <sub>RTC</sub> Fixed Current, LP1 Mode	I <sub>DDRTC_FLP1</sub>	RTC enabled, retention regulator powered by V <sub>DD12</sub>		505		nA
V <sub>DD12</sub> Fixed Current, LP0 Mode	I <sub>DD12_FLP0</sub>			14		nA
V <sub>DD18</sub> Fixed Current, LP0 Mode	I <sub>DD18_FLP0</sub>			120		nA
V <sub>RTC</sub> Fixed Current, LP0 Mode	I <sub>DDRTC_FLP0</sub>	RTC enabled		505		nA
		RTC disabled		105		
LP2 Mode Resume Time	t <sub>LP2_ON</sub>			0		μs
LP1 Mode Resume Time	t <sub>LP1_ON</sub>			5		μs
LP0 Mode Resume Time	t <sub>LP0_ON</sub>	Polling flash ready		11		μs
<b>JTAG</b>						
Input Low Voltage for TCK, TMS, TDI	V <sub>IL</sub>				0.3 x V <sub>DDIO</sub>	V
Input High Voltage for TCK, TMS, TDI	V <sub>IH</sub>			0.7 x V <sub>DDIO</sub>		V
Output Low Voltage for TDO	V <sub>OL</sub>			0.2	0.4	V
Output High Voltage for TDO	V <sub>OH</sub>			V <sub>DDIO</sub> - 0.4		

**Electrical Characteristics (continued)**

(Limits are 100% tested at  $T_A = +25^\circ\text{C}$  and  $T_A = +85^\circ\text{C}$ . Limits over the operating temperature range and relevant supply voltage range are guaranteed by design and characterization. Specifications marked GBD are guaranteed by design and not production tested. Specifications to  $-20^\circ\text{C}$  are guaranteed by design and are not production tested.)

PARAMETER	SYMBOL	CONDITIONS	MIN	TYP	MAX	UNITS
<b>CLOCKS</b>						
System Clock Frequency	$f_{\text{CK}}$		0.001		98	MHz
System Clock Period	$t_{\text{CK}}$			$1/f_{\text{CK}}$		ns
Internal Relaxation Oscillator Frequency	$f_{\text{INTCLK}}$	Factory default	94	96	98	MHz
		Firmware trimmed, required for USB compliance	95.76	96	96.24	
Internal RC Oscillator Frequency	$f_{\text{RCCLK}}$		3.9	4	4.1	MHz
RTC Input Frequency	$f_{32\text{KIN}}$	32kHz watch crystal		32.768		kHz
RTC Operating Current	$I_{\text{RTC\_LP23}}$	LP2 or LP3 mode		0.7		$\mu\text{A}$
	$I_{\text{RTC\_LP01}}$	LP0 or LP1 mode		0.35		
RTC Power-Up Time	$t_{\text{RTC\_ON}}$			250		ms
<b>GENERAL-PURPOSE I/O</b>						
Input Low Voltage for All GPIO Pins	$V_{\text{IL}}$	$V_{\text{DDIO}}$ selected as I/O supply			$0.3 \times V_{\text{DDIO}}$	V
		$V_{\text{DDIOH}}$ selected as I/O supply			$0.3 \times V_{\text{DDIOH}}$	
Input Low Voltage for RSTN	$V_{\text{IL}}$				$0.3 \times V_{\text{RTC}}$	V
Input Low Voltage for SRSTN	$V_{\text{IL}}$				$0.3 \times V_{\text{DDIO}}$	
Input High Voltage for All GPIO Pins	$V_{\text{IH}}$	$V_{\text{DDIO}}$ selected as I/O supply	$0.7 \times V_{\text{DDIO}}$			V
		$V_{\text{DDIOH}}$ selected as I/O supply	$0.7 \times V_{\text{DDIOH}}$			
Input High Voltage for RSTN	$V_{\text{IH}}$		$0.7 \times V_{\text{RTC}}$			V
Input High Voltage for SRSTN	$V_{\text{IH}}$		$0.7 \times V_{\text{DDIO}}$			V
Input Hysteresis (Schmitt)	$V_{\text{IHYS}}$			300		mV
Output Low Voltage for All GPIO Pins	$V_{\text{OL}}$	$V_{\text{DDIO}} = V_{\text{DDIOH}} = 1.71\text{V}$ , $V_{\text{DDIO}}$ selected as I/O supply, $I_{\text{OL}} = 4\text{mA}$ , normal drive configuration		0.2	0.4	V
		$V_{\text{DDIO}} = V_{\text{DDIOH}} = 1.71\text{V}$ , $V_{\text{DDIO}}$ selected as I/O supply, $I_{\text{OL}} = 24\text{mA}$ , fast drive configuration		0.2	0.4	
		$V_{\text{DDIO}} = 1.71\text{V}$ , $V_{\text{DDIOH}} = 2.97\text{V}$ , $V_{\text{DDIOH}}$ selected as I/O supply, $I_{\text{OL}} = 300\mu\text{A}$		0.2	0.45	

**ADC Electrical Characteristics (continued)**

(Internal bandgap reference selected, ADC\_SCALE = ADC\_REFSCAL = 1, unless otherwise specified. Specifications marked GBD are guaranteed by design and not production tested.)

PARAMETER	SYMBOL	CONDITIONS	MIN	TYP	MAX	UNITS
ADC Setup Time	$t_{\text{ADC\_SU}}$	Any powerup of: ADC clock, ADC bias, reference buffer or input buffer to CpuAdcStart			10	$\mu\text{s}$
		Any power-up of: ADC clock or ADC bias to CpuAdcStart			48	$t_{\text{ACLK}}$
ADC Output Latency	$t_{\text{ADC}}$			1025		$t_{\text{ACLK}}$
ADC Sample Rate	$f_{\text{ADC}}$				7.8	ksps
ADC Input Leakage	$I_{\text{ADC\_LEAK}}$	AIN0 or AIN1, ADC inactive or channel not selected		0.12	4	nA
		AIN2 or AIN3, ADC inactive or channel not selected.		0.02	1	
AIN0/AIN1 Resistor Divider Error		ADC_CHSEL = 4 or 5, not including ADC offset/gain error		$\pm 2$		LSb
Full-Scale Voltage	$V_{\text{FS}}$	ADC code = 0x3FF		1.2		V
External Reference Voltage	$V_{\text{REF\_EXT}}$	ADC_XREF = 1	1.17	1.23	1.29	V
Bandgap Temperature Coefficient	$V_{\text{TEMPCO}}$	Box method		30		ppm
Reference Dynamic Current	$I_{\text{REF\_EXT}}$	ADC_XREF = 1, ADC active		4.1		$\mu\text{A}$
Reference Input Capacitance	$C_{\text{REFIN}}$	Dynamically switched capacitance, ADC_XREF = 1, ADC active		250		fF

**SPI MASTER/SPIX MASTER Electrical Characteristics**

(Guaranteed by design and not production tested.)

PARAMETER	SYMBOL	CONDITIONS	MIN	TYP	MAX	UNITS
Operating Frequency	$f_{MCK}$				48	MHz
SCLK Period	$t_{MCK}$			$1/f_{MCK}$		ns
SCLK Output Pulse-Width High/Low	$t_{MCH}, t_{MCL}$		$t_{MCK}/2$			ns
MOSI Output Hold Time After SCLK Sample Edge	$t_{MOH}$		$t_{MCK}/2$			ns
MOSI Output Valid to Sample Edge	$t_{MOV}$		$t_{MCK}/2$			ns
MISO Input Valid to SCLK Sample Edge Setup	$t_{MIS}$		3			ns
MISO Input to SCLK Sample Edge	$t_{MIH}$			0		ns

**SPI Timing:**

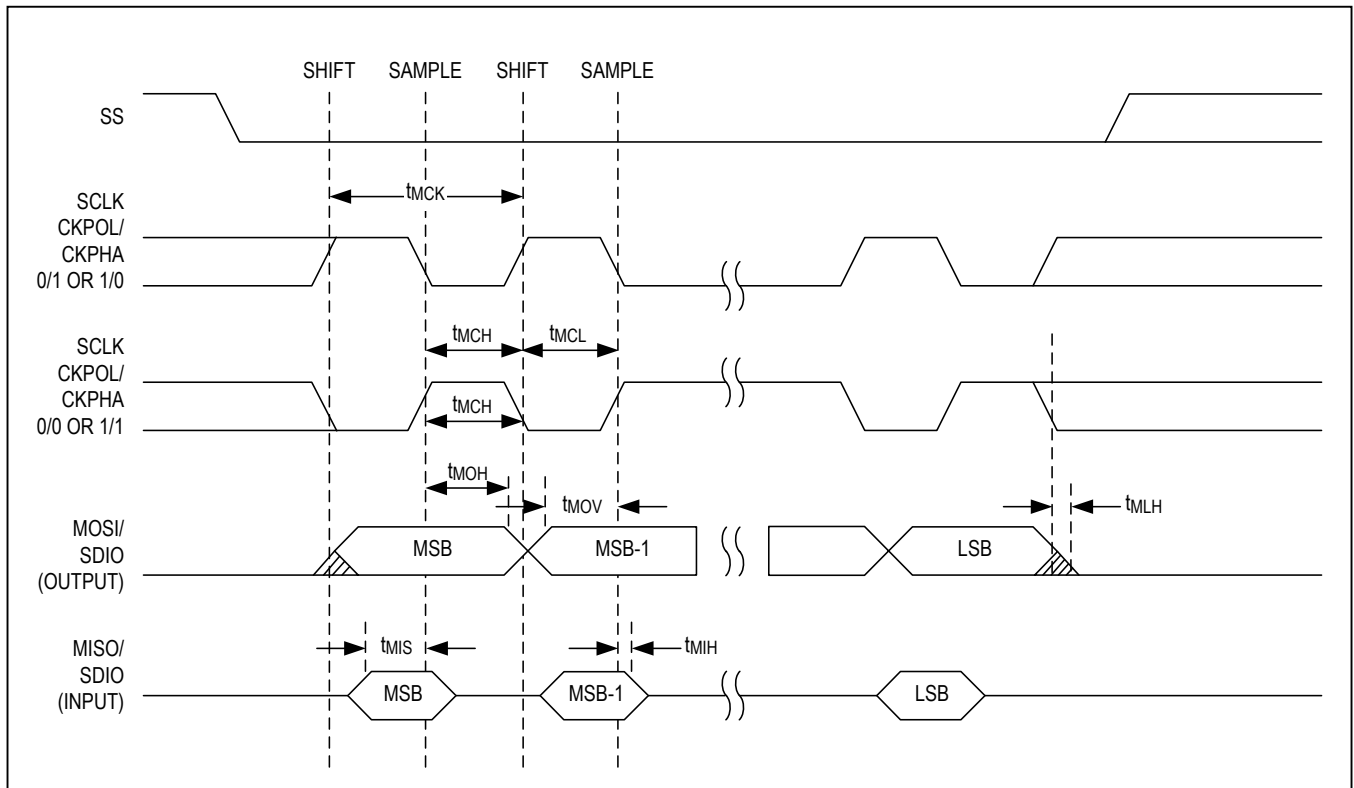

Figure 1. SPI Master/SPIX Master Communications Timing Diagram

**Electrical Characteristics - I<sup>2</sup>C BUS**

(Guaranteed by design and not production tested.)

PARAMETER	SYMBOL	CONDITIONS	MIN	TYP	MAX	UNITS
SCL Clock Frequency	f <sub>SCL</sub>	Standard mode		100		kHz
		Fast mode		400		
Input High Voltage	V <sub>IH_I2C</sub>	Fast mode, V <sub>DDIO</sub> selected as I/O supply	0.7 × V <sub>DDIO</sub>			V
		Fast mode, V <sub>DDIOH</sub> selected as I/O supply	0.7 × V <sub>DDIOH</sub>			
		Standard mode, V <sub>DDIO</sub> selected as I/O supply	0.7 × V <sub>DDIO</sub>			
		Standard mode, V <sub>DDIOH</sub> selected as I/O supply	0.7 × V <sub>DDIOH</sub>			
Input Low Voltage	V <sub>IL_I2C</sub>	Fast mode, V <sub>DDIO</sub> selected as I/O supply			0.3 × V <sub>DDIO</sub>	V
		Fast mode, V <sub>DDIOH</sub> selected as I/O supply			0.3 × V <sub>DDIOH</sub>	
		Standard mode, V <sub>DDIO</sub> selected as I/O supply			0.3 × V <sub>DDIO</sub>	
		Standard mode, V <sub>DDIOH</sub> selected as I/O supply			0.3 × V <sub>DDIOH</sub>	
Input Hysteresis (Schmitt)	V <sub>IHYS_I2C</sub>	Fast-mode		300		mV
Output Logic-Low (Open Drain or Open Collector)	V <sub>OL_I2C</sub>	V <sub>DDIO</sub> = V <sub>DDIOH</sub> = 1.71V, V <sub>DDIO</sub> selected as I/O supply, I <sub>OL</sub> = 4mA, normal drive configuration		0.2	0.4	V
		V <sub>DDIO</sub> = 1.71V, V <sub>DDIOH</sub> = 2.97V, V <sub>DDIOH</sub> selected as I/O supply, I <sub>OL</sub> = 300μA		0.2	0.45	



Pin Configuration

100-WLP

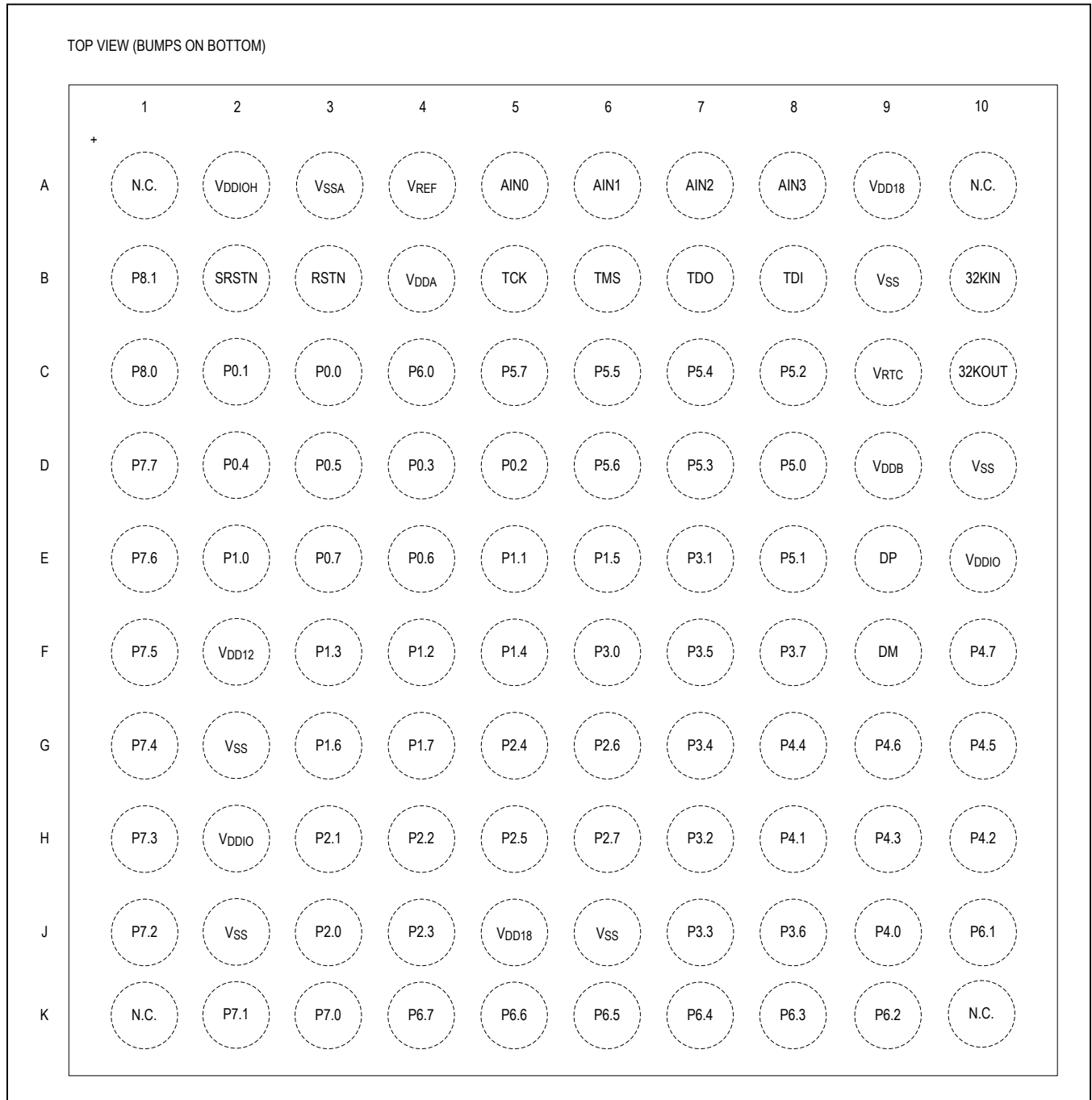

## Bump Description

BUMP	NAME	FUNCTION
<b>POWER PINS</b>		
D9	V <sub>DDDB</sub>	USB Transceiver Supply Voltage. This pin must be bypassed to V <sub>SS</sub> with a 1.0μF capacitor as close as possible to the package.
F2	V <sub>DD12</sub>	1.2V Nominal Supply Voltage. This pin must be bypassed to V <sub>SS</sub> with a 1.0μF capacitor as close as possible to the package.
C9	V <sub>RTC</sub>	RTC Supply Voltage. This pin must be bypassed to V <sub>SS</sub> with a 1.0μF capacitor as close as possible to the package.
B4	V <sub>DDA</sub>	Analog Supply Voltage. This pin must be bypassed to V <sub>SSA</sub> with a 1.0μF capacitor as close as possible to this pin.
J5, A9	V <sub>DD18</sub>	1.8V Supply Voltage. This pin must be bypassed to V <sub>SS</sub> with a 1.0μF capacitor as close as possible to the package.
H2, E10	V <sub>DDIO</sub>	I/O Supply Voltage. $1.8V \leq V_{DDIO} \leq 3.6V$ . See EC table for V <sub>DDIO</sub> specification. This pin must be bypassed to V <sub>SS</sub> with a 1.0μF capacitor as close as possible to the package.
A2	V <sub>DDIOH</sub>	I/O Supply Voltage, High. $1.8V \leq V_{DDIOH} \leq 3.6V$ , always with $V_{DDIOH} \geq V_{DDIO}$ . See EC table for V <sub>DDIOH</sub> specification. This pin must be bypassed to V <sub>SS</sub> with a 1.0μF capacitor as close as possible to the package.
A4	V <sub>REF</sub>	ADC Reference. This pin must be left unconnected if an external reference is not used.
B9, D10, G2, J6, J2	V <sub>SS</sub>	Digital Ground
A3	V <sub>SSA</sub>	Analog Ground
<b>CLOCK PINS</b>		
C10	32KOUT	32KHz Crystal Oscillator Output
B10	32KIN	32kHz Crystal Oscillator Input. Connect a 6pF 32kHz crystal between 32KIN and 32KOUT for RTC operation. Optionally, an external clock source can be driven on 32KIN if the 32KOUT pin is left unconnected. A 32kHz crystal or external clock source is required for proper USB operation.
<b>USB PINS</b>		
E9	DP	USB DP Signal. This bidirectional pin carries the positive differential data or single-ended data. This pin is weakly pulled high internally when the USB is disabled.
F9	DM	USB DM Signal. This bidirectional pin carries the negative differential data or single-ended data. This pin is weakly pulled high internally when the USB is disabled.
<b>JTAG PINS</b>		
B5	TCK/SWCLK	JTAG Clock or Serial Wire Debug Clock. This pin has an internal 25KΩ pullup to V <sub>DDIO</sub> .
B6	TMS/SWDIO	JTAG Test Mode Select or Serial Wire Debug I/O. This pin has an internal 25KΩ pullup to V <sub>DDIO</sub> .
B7	TDO	JTAG Test Data Output
B8	TDI	JTAG Test Data Input. This pin has an internal 25kΩ pullup to V <sub>DDIO</sub> .

## Bump Description (continued)

BUMP	NAME	FUNCTION
<b>RESET PINS</b>		
B3	RSTN	Hardware Power Reset (Active-Low) Input. The device remains in reset while this pin is in its active state. When the pin transitions to its inactive state, the device performs a POR reset (resetting all logic on all supplies except for real-time clock circuitry) and begins execution. This pin is internally connected with an internal 25kΩ pullup to the $V_{RTC}$ supply. This pin should be left unconnected if the system design does not provide a reset signal to the device.
B2	SRSTN	<p>Software Reset, Active-Low Input/Output. The device remains in software reset while this pin is in its active state. When the pin transitions to its inactive state, the device performs a reset to the ARM core, digital registers and peripherals (resetting most of the core logic on the <math>V_{DD12}</math> supply). This reset does not affect the POR only registers, RTC logic, ARM debug engine or JTAG debugger allowing for a soft reset without having to reconfigure all registers.</p> <p>After the device senses SRSTN as a logic 0, the pin automatically reconfigures as an output sourcing a logic 0. The device continues to output for 6 system clock cycles and then repeats the input sensing/output driving until SRSTN is sensed inactive.</p> <p>This pin is internally connected with an internal 25kΩ pullup to the <math>V_{DDIO}</math> supply. This pin should be left unconnected if the system design does not provide a reset signal to the device.</p>
<b>GENERAL-PURPOSE I/O AND SPECIAL FUNCTIONS (See the <a href="#">Applications Information</a> section for GPIO Matrix)</b>		
C3	P0.0	GPIO Port 0.0
C2	P0.1	GPIO Port 0.1
D5	P0.2	GPIO Port 0.2
D4	P0.3	GPIO Port 0.3
D2	P0.4	GPIO Port 0.4
D3	P0.5	GPIO Port 0.5
E4	P0.6	GPIO Port 0.6
E3	P0.7	GPIO Port 0.7
E2	P1.0	GPIO Port 1.0
E5	P1.1	GPIO Port 1.1
F4	P1.2	GPIO Port 1.2
F3	P1.3	GPIO Port 1.3
F5	P1.4	GPIO Port 1.4
E6	P1.5	GPIO Port 1.5
G3	P1.6	GPIO Port 1.6
G4	P1.7	GPIO Port 1.7
J3	P2.0	GPIO Port 2.0
H3	P2.1	GPIO Port 2.1
H4	P2.2	GPIO Port 2.2
J4	P2.3	GPIO Port 2.3
G5	P2.4	GPIO Port 2.4
H5	P2.5	GPIO Port 2.5
G6	P2.6	GPIO Port 2.6

**Bump Description (continued)**

BUMP	NAME	FUNCTION
H6	P2.7	GPIO Port 2.7
F6	P3.0	GPIO Port 3.0
E7	P3.1	GPIO Port 3.1
H7	P3.2	GPIO Port 3.2
J7	P3.3	GPIO Port 3.3
G7	P3.4	GPIO Port 3.4
F7	P3.5	GPIO Port 3.5
J8	P3.6	GPIO Port 3.6
F8	P3.7	GPIO Port 3.7
J9	P4.0	GPIO Port 4.0
H8	P4.1	GPIO Port 4.1
H10	P4.2	GPIO Port 4.2
H9	P4.3	GPIO Port 4.3
G8	P4.4	GPIO Port 4.4
G10	P4.5	GPIO Port 4.5
G9	P4.6	GPIO Port 4.6
F10	P4.7	GPIO Port 4.7
D8	P5.0	GPIO Port 5.0
E8	P5.1	GPIO Port 5.1
C8	P5.2	GPIO Port 5.2
D7	P5.3	GPIO Port 5.3
C7	P5.4	GPIO Port 5.4
C6	P5.5	GPIO Port 5.5
D6	P5.6	GPIO Port 5.6
C5	P5.7	GPIO Port 5.7
C4	P6.0	GPIO Port 6.0
J10	P6.1	GPIO Port 6.1
K9	P6.2	GPIO Port 6.2
K8	P6.3	GPIO Port 6.3
K7	P6.4	GPIO Port 6.4
K6	P6.5	GPIO Port 6.5
K5	P6.6	GPIO Port 6.6
K4	P6.7	GPIO Port 6.7
K3	P7.0	GPIO Port 7.0
K2	P7.1	GPIO Port 7.1
J1	P7.2	GPIO Port 7.2
H1	P7.3	GPIO Port 7.3
G1	P7.4	GPIO Port 7.4
F1	P7.5	GPIO Port 7.5

**Bump Description (continued)**

<b>BUMP</b>	<b>NAME</b>	<b>FUNCTION</b>
E1	P7.6	GPIO Port 7.6
D1	P7.7	GPIO Port 7.7
C1	P8.0	GPIO Port 8.0
B1	P8.1	GPIO Port 8.1
A1	N.C.	Not Connected.
A10	N.C.	Not Connected.
K1	N.C.	Not Connected.
K10	N.C.	Not Connected.
<b>ANALOG INPUT PINS</b>		
A5	AIN0	ADC Input 0. 5V tolerant input.
A6	AIN1	ADC Input 1. 5V tolerant input.
A7	AIN2	ADC Input 2
A8	AIN3	ADC Input 3

## Detailed Description

The MAX32630/MAX32631 is a low-power, mixed signal microcontroller based on the ARM Cortex-M4 32-bit core with a maximum operating frequency of 96MHz. The MAX32631 is a secure version of the MAX32630, incorporating a trust protection unit (TPU) with encryption and advanced security features.

Application code executes from an onboard 2MB program flash memory, with up to 512KB SRAM available for general application use. An 8KB instruction cache improves execution throughput, and a transparent code scrambling scheme is used to protect customer intellectual property residing in the program flash memory. Additionally, a SPI execute in place (XIP) external memory interface allows application code and data (up to 16MB) to be accessed from an external SPI memory device.

A 10-bit delta-sigma ADC is provided with a multiplexer front end for four external input channels (two of which are 5V tolerant) and six internal channels. An onboard temperature sensor block allows direct die temperature measurement without requiring any external system components. Dedicated divided supply input channels allow direct monitoring of onboard power supplies such as  $V_{DD12}$ ,  $V_{DD18}$ ,  $V_{DDB}$ , and  $V_{RTC}$  by the ADC. Built-in limit monitors allow converted input samples to be compared against user-configurable high and low limits, with an option to trigger an interrupt and wake the CPU from a low power mode if attention is required.

A wide variety of communications and interface peripherals are provided, including a USB 2.0 slave interface, three master SPI interfaces, one slave SPI interface, four UART interfaces with multidrop support, three master I<sup>2</sup>C interfaces, and a slave I<sup>2</sup>C interface.

### ARM Cortex-M4F Processor

The ARM Cortex-M4F processor is ideal for the emerging category of wearable medical and wellness applications. The architecture combines high-efficiency signal processing functionality with low power, low cost, and ease of use. The Cortex-M4F DSP supports single instruction multiple data (SIMD) path DSP extensions, providing:

- Four parallel 8-bit add/sub
- Floating point single precision

- Two parallel 16-bit add/sub
- Two parallel MACs
- 32- or 64-bit accumulate
- Signed, unsigned, data with or without saturation

### Analog-to-Digital Converter

The 10-bit delta-sigma ADC provides 4 external inputs and can also be configured to measure all internal power supplies. It operates at a maximum of 7.8ksps. AIN0 and AIN1 are 5V tolerant, making them suitable for monitoring batteries.

An optional feature allows samples captured by the ADC to be automatically compared against user-programmable high and low limits. Up to four channel limit pairs can be configured in this way. The comparison allows the ADC to trigger an interrupt (and potentially wake the CPU from a low-power sleep mode) when a captured sample goes outside the preprogrammed limit range. Since this comparison is performed directly by the sample limit monitors, it can be performed even while the main CPU is suspended in a low power mode.

The ADC reference is selectable:

- Internal bandgap
- External reference
- $V_{DD18}$ . This option disables the reference buffer to minimize power consumption.

### Pulse Train Engine

Sixteen independent pulse train generators provide either a square wave or a repeating pattern from 2 bits to 32 bits in length. The frequency of each enabled pulse train generator is also set separately, based on a divide down (divide by 2, divide by 4, divide by 8, etc.) of the input pulse train module clock.

Any single pulse train generator or any desired group of pulse train generators can be restarted at the beginning of their patterns and synchronized with one another ensuring simultaneous startup. Additionally, each pulse train can operate in a single shot mode.

**Clocking Scheme**

The high-frequency internal relaxation oscillator operates at a nominal frequency of 96MHz. It is the primary clock source for the digital logic and peripherals. Select a 4MHz internal oscillator to optimize active power consumption. Wakeup is possible from either the 4MHz internal oscillator or the 96MHz internal oscillator. An external 32.768kHz timebase is required when using the RTC or USB features of the device. The time base can be generated by attaching a 32kHz crystal connected between 32KIN and 32KOUT, or an external clock source can also be applied to the 32KIN pin. The external clock source must meet the electrical/timing requirements in the EC

table. The 32kHz output can be directed out to pin P1.7 and remains active in all low power modes including LP0.

**Interrupt Sources**

The ARM nested vector interrupt controller (NVIC) provides a high-speed, deterministic interrupt response, interrupt masking, and multiple interrupt sources. Each peripheral is connected to the NVIC and can have multiple interrupt flags to indicate the specific source of the interrupt within the peripheral. 55 distinct interrupts can be grouped by firmware into 8 levels of priority (including internal and external interrupts). There are 9 interrupts for the GPIO ports, one for each port.

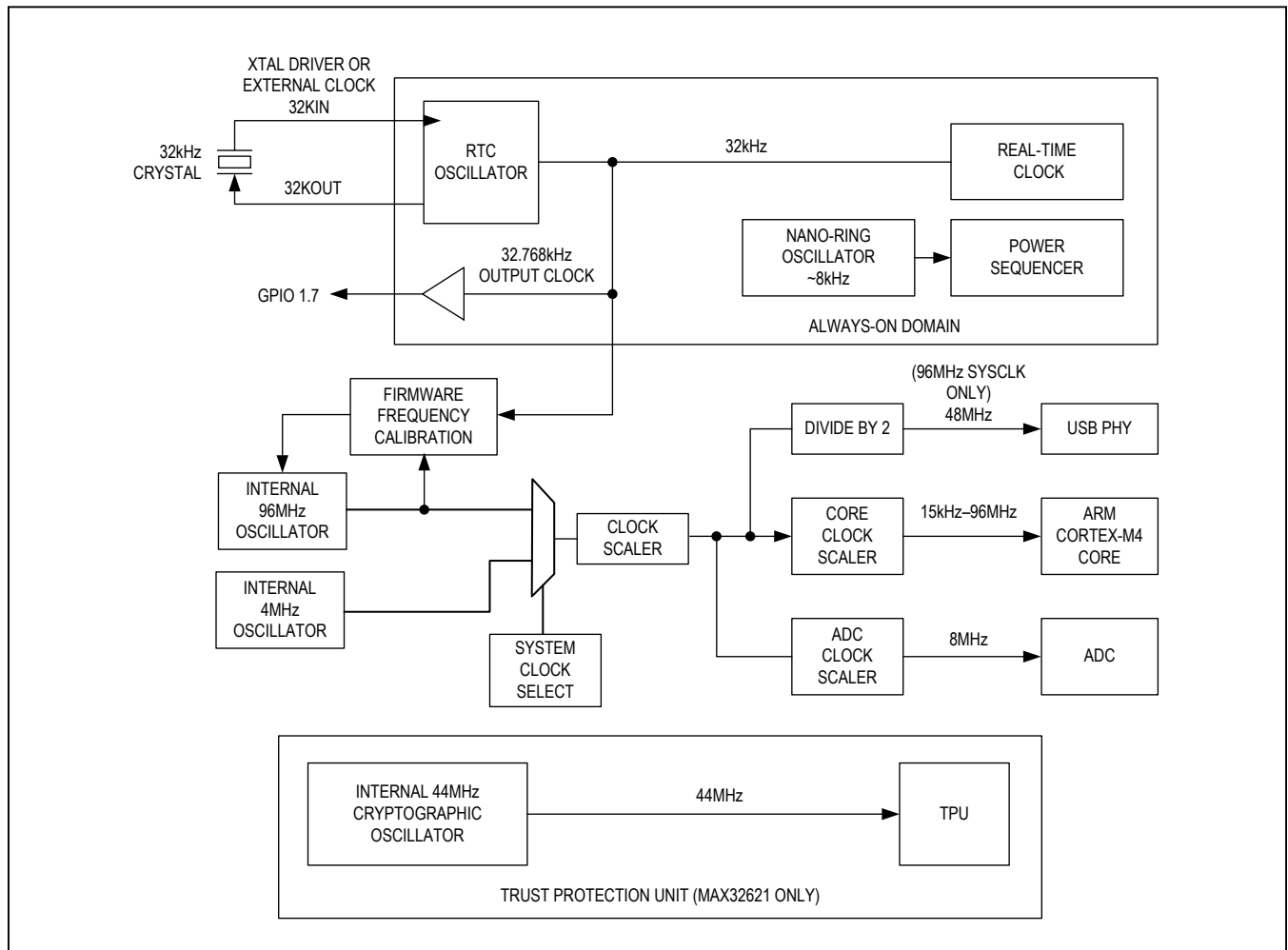

Figure 2. MAX32630/MAX32631 Clock Scheme

## Serial Peripherals

### USB Controller

The integrated USB slave controller is compliant with the full-speed (12Mb/s) USB 2.0 specification. The integrated USB physical interface (PHY) reduces board space and system cost. An integrated voltage regulator enables smart switching between the main supply and  $V_{DDB}$  when connected to a USB host controller.

The USB controller supports DMA for the endpoint buffers. A total of 7 endpoint buffers are supported with configurable selection of IN or OUT in addition to endpoint 0.

An external 32kHz crystal or clock source is required for USB operation, even if the RTC function is not used. Although the USB timing is derived from the internal 96MHz oscillator, the default accuracy is not sufficient for USB operation. Periodic firmware adjustments of the 96MHz oscillator, using the 32kHz timebase as a reference, are necessary to comply with the USB timing requirements.

### I<sup>2</sup>C Master and Slave Ports

The I<sup>2</sup>C interface is a bidirectional, two-wire serial bus that provides a medium-speed communications network. It can operate as a one-to-one, one-to-many or many-to-many communications medium. Three I<sup>2</sup>C master engines and one I<sup>2</sup>C-selectable slave engine interface to a wide variety of I<sup>2</sup>C-compatible peripherals. These engines support both Standard-mode and Fast-mode I<sup>2</sup>C standards. The slave engine shares the same I/O port as the master engines and is selectable through the I/O configuration settings. It provides the following features:

- Master or slave mode operation
- Supports standard (7-bit) addressing or 10-bit addressing
- Support for clock stretching to allow slower slave devices to operate on higher speed busses
- Multiple transfer rates
  - Standard-mode: 100kbps
  - Fast-mode: 400kbps
- Internal filter to reject noise spikes
- Receiver FIFO depth of 16 bytes
- Transmitter FIFO depth of 16 bytes

### Serial Peripheral Interface—Master

The SPI master-mode-only (SPIM) interface operates independently in a single or multiple slave system and is fully accessible to the user application.

The SPI ports provide a highly configurable, flexible, and efficient interface to communicate with a wide variety of SPI slave devices. The three SPI master ports (SPI0, SPI1, SPI2) support the following features:

- SPI modes (0, 3) for single-bit communication
- 3- or 4-wire mode for single-bit slave device communication
- Full-duplex operation in single-bit, 4-wire mode
- Dual and Quad I/O supported
- Up to 5 slave select lines per port
- Up to 2 slave ready lines
- Programmable interface timing
- Programmable SCK frequency and duty cycle
- High-speed AHB access to transmit and receive using 32-byte FIFOs
- SS assertion and deassertion timing with respect to leading/trailing SCK edge

### Serial Peripheral Interface—Slave

The SPI slave (SPIS) port provide a highly configurable, flexible, and efficient interface to communicate with a wide variety of SPI master devices. The SPI slave interface supports the following features:

- Supports SPI modes 0 and 3
- Full-duplex operation in single-bit, 4-wire mode
- Slave select polarity fixed (active low)
- Dual and Quad I/O supported
- High-speed AHB access to transmit and receive using 32-byte FIFOs
- Four interrupts to monitor FIFO levels

### Serial Peripheral Interface Execute in Place (SPIX) Master

The SPI execute in place (SPIX) master allows the CPU to transparently execute instructions stored in an external SPI flash. Instructions fetched through the SPIX master are cached just like instructions fetched from internal program memory. The SPIX master can also be used to access large amounts of external static data that would otherwise reside in internal data memory.



## UART

All four universal asynchronous receiver-transmitter (UART) interfaces support full-duplex asynchronous communication with optional hardware flow control (HFC) modes to prevent data overruns. If HFC mode is enabled on a given port, the system uses two extra pins to implement the industry standard request to send (RTS) and clear to send (CTS) methodology. Each UART is individually programmable.

- 2-wire interface or 4-wire interface with flow control
- 32-byte send/receive FIFO
- Full-duplex operation for asynchronous data transfers
- Programmable interrupt for receive and transmit
- Independent baud-rate generator
- Programmable 9th bit parity support
- Multidrop support
- Start/stop bit support
- Hardware flow control using RTS/CTS
- Maximum baud rate 1843.2kB

## Trust Protection Unit (TPU) (MAX32631 Only)

The TPU enhances cryptographic data security for valuable intellectual property (IP) and data. A high-speed, dedicated, hardware-based math accelerator (MAA) performs mathematical computations that support strong cryptographic algorithms including:

- AES-128
- AES-192
- AES-256
- 1024-bit DSA
- 2048-bit (CRT)

The device provides a pseudo-random number generator that can be used to create cryptographic keys for any application. A user-selectable entropy source further increases the randomness and key strength.

The secure bootloader protects against unauthorized access to program memory.

## Peripheral Management Unit (PMU)

The PMU is a DMA-based link list processing engine that performs operations and data transfers involving memory and/or peripherals in the advanced peripheral bus (APB) and advanced high-performance bus (AHB) peripheral memory space while the main CPU is in a sleep state. This allows low-overhead peripheral operations to be performed without the CPU, significantly reducing overall power consumption. Using the PMU with the CPU in a sleep state provides a lower noise environment critical for obtaining optimum ADC performance.

Key features of the PMU engine include:

- Six independent channels with round-robin scheduling allows for multiple parallel operations
- Programmed using SRAM-based PMU op codes
- PMU action can be initiated from interrupt conditions from peripherals without CPU
- Integrated AHB bus master
- Coprocessor-like state machine

## Additional Documentation

Engineers must have the following documents to fully use this device:

- This data sheet, containing pin descriptions, feature overviews, and electrical specifications
- The device-appropriate user guide, containing detailed information and programming guidelines for core features and peripherals
- Errata sheets for specific revisions noting deviations from published specifications

For information regarding these documents, visit Technical Support at [support.maximintegrated.com/micro](http://support.maximintegrated.com/micro).

## Development and Technical Support

Contact technical support for information about highly versatile, affordable development tools, available from Maxim Integrated and third-party vendors.

- Evaluation kits
- Software development kit
- Compilers
- Integrated development environments (IDEs)
- USB interface modules for programming and debugging

For technical support, go to [support.maximintegrated.com/micro](http://support.maximintegrated.com/micro)

## Applications Information

Table 1. General-Purpose I/O Matrix

	PRIMARY FUNCTION	SECONDARY FUNCTION	TERTIARY FUNCTION	QUATER-NARY FUNCTION	PULSE TRAIN	TIMER INPUT	GPIO INTERRUPT
P0.0	UART0A_RX	UART0B_TX			PT_PT0	TIMER_TMR0	GPIO_INT(P0)
P0.1	UART0A_TX	UART0B_RX			PT_PT1	TIMER_TMR1	GPIO_INT(P0)
P0.2	UART0A_CTS	UART0B_RTS			PT_PT2	TIMER_TMR2	GPIO_INT(P0)
P0.3	UART0A_RTS	UART0B_CTS			PT_PT3	TIMER_TMR3	GPIO_INT(P0)
P0.4	SPIM0A_SCK				PT_PT4	TIMER_TMR4	GPIO_INT(P0)
P0.5	SPIM0A_MOSI/ SDIO0				PT_PT5	TIMER_TMR5	GPIO_INT(P0)
P0.6	SPIM0A_MISO/ SDIO1				PT_PT6	TIMER_TMR0	GPIO_INT(P0)
P0.7	SPIM0A_SS0				PT_PT7	TIMER_TMR1	GPIO_INT(P0)
P1.0	SPIM1A_SCK	SPIX0A_SCK			PT_PT8	TIMER_TMR2	GPIO_INT(P1)
P1.1	SPIM1A_MOSI/ SDIO0	SPIX0A_ SDIO0			PT_PT9	TIMER_TMR3	GPIO_INT(P1)
P1.2	SPIM1A_MISO/ SDIO1	SPIX0A_ SDIO1			PT_PT10	TIMER_TMR4	GPIO_INT(P1)
P1.3	SPIM1A_SS0	SPIX0A_SS0			PT_PT11	TIMER_TMR5	GPIO_INT(P1)
P1.4	SPIM1A_SDIO2	SPIX0A_ SDIO2			PT_PT12	TIMER_TMR0	GPIO_INT(P1)
P1.5	SPIM1A_SDIO3	SPIX0A_ SDIO3			PT_PT13	TIMER_TMR1	GPIO_INT(P1)
P1.6	I2CM0A/S0A_SDA				PT_PT14	TIMER_TMR2	GPIO_INT(P1)
P1.7	I2CM0A/S0A_SCL				PT_PT15	TIMER_TMR3	GPIO_INT(P1)
P2.0	UART1A_RX	UART1B_TX			PT_PT0	TIMER_TMR4	GPIO_INT(P2)
P2.1	UART1A_TX	UART1B_RX			PT_PT1	TIMER_TMR5	GPIO_INT(P2)
P2.2	UART1A_CTS	UART1B_RTS			PT_PT2	TIMER_TMR0	GPIO_INT(P2)
P2.3	UART1A_RTS	UART1B_CTS			PT_PT3	TIMER_TMR1	GPIO_INT(P2)
P2.4	SPIM2A_SCK				PT_PT4	TIMER_TMR2	GPIO_INT(P2)
P2.5	SPIM2A_MOSI/ SDIO0				PT_PT5	TIMER_TMR3	GPIO_INT(P2)
P2.6	SPIM2A_MISO/ SDIO1				PT_PT6	TIMER_TMR4	GPIO_INT(P2)
P2.7	SPIM2A_SS0				PT_PT7	TIMER_TMR5	GPIO_INT(P2)
P3.0	UART2A_RX	UART2B_TX			PT_PT8	TIMER_TMR0	GPIO_INT(P3)
P3.1	UART2A_TX	UART2B_RX			PT_PT9	TIMER_TMR1	GPIO_INT(P3)
P3.2	UART2A_CTS	UART2B_RTS			PT_PT10	TIMER_TMR2	GPIO_INT(P3)
P3.3	UART2A_RTS	UART2B_CTS			PT_PT11	TIMER_TMR3	GPIO_INT(P3)
P3.4	I2CM1A/S0B_SDA	SPIM2A_SS1			PT_PT12	TIMER_TMR4	GPIO_INT(P3)

Table 1. General-Purpose I/O Matrix (continued)

	PRIMARY FUNCTION	SECONDARY FUNCTION	TERTIARY FUNCTION	QUATER- NARY FUNC- TION	PULSE TRAIN	TIMER INPUT	GPIO INTER- RUPT
P3.5	I2CM1A/S0B_SCL	SPIM2A_SS2			PT_PT13	TIMER_TMR5	GPIO_INT(P3)
P3.6	SPIM1A_SS1	SPIX_SS1			PT_PT14	TIMER_TMR0	GPIO_INT(P3)
P3.7	SPIM1A_SS2	SPIX_SS2			PT_PT15	TIMER_TMR1	GPIO_INT(P3)
P4.0	OWM_I/O	SPIM2A_SR0			PT_PT0	TIMER_TMR2	GPIO_INT(P4)
P4.1	OWM_PUPEN	SPIM2A_SR1			PT_PT1	TIMER_TMR3	GPIO_INT(P4)
P4.2	SPIM0A_SDIO2	SPIS0A_ SDIO2			PT_PT2	TIMER_TMR4	GPIO_INT(P4)
P4.3	SPIM0A_SDIO3	SPIS0A_ SDIO3			PT_PT3	TIMER_TMR5	GPIO_INT(P4)
P4.4	SPIM0A_SS1	SPIS0A_ SCLK			PT_PT4	TIMER_TMR0	GPIO_INT(P4)
P4.5	SPIM0A_SS2	SPIS0A_ MOSI/SDIO0			PT_PT5	TIMER_TMR1	GPIO_INT(P4)
P4.6	SPIM0A_SS3	SPIS0A_ MISO/SDIO1			PT_PT6	TIMER_TMR2	GPIO_INT(P4)
P4.7	SPIM0A_SS4	SPIS0A_SSEL			PT_PT7	TIMER_TMR3	GPIO_INT(P4)
P5.0		SPIM2B_SCK			PT_PT8	TIMER_TMR4	GPIO_INT(P5)
P5.1		SPIM2B_ MOSI/SDIO0			PT_PT9	TIMER_TMR5	GPIO_INT(P5)
P5.2		SPIM2B_ MISO/SDIO1			PT_PT10	TIMER_TMR0	GPIO_INT(P5)
P5.3		SPIM2B_SS0	UART3A_RX	UART3B_TX	PT_PT11	TIMER_TMR1	GPIO_INT(P5)
P5.4		SPIM2B_ SDIO2	UART3A_TX	UART3B_RX	PT_PT12	TIMER_TMR2	GPIO_INT(P5)
P5.5		SPIM2B_ SDIO3	UART3A_CTS	UART3B_RTS	PT_PT13	TIMER_TMR3	GPIO_INT(P5)
P5.6		SPIM2B_SR	UART3A_RTS	UART3B_CTS	PT_PT14	TIMER_TMR4	GPIO_INT(P5)
P5.7	I2CM2A/S0C_SDA	SPIM2B_SS1			PT_PT15	TIMER_TMR5	GPIO_INT(P5)
P6.0	I2CM2A/S0C_SCL	SPIM2B_SS2			PT_PT0	TIMER_TMR0	GPIO_INT(P6)
P6.1	SPIM2C_SCK	SPIS0B_SCK			PT_PT1	TIMER_TMR1	GPIO_INT(P6)
P6.2	SPIM2C_MOSI/ SDIO0	SPIS0B_ MOSI/SDIO0			PT_PT2	TIMER_TMR2	GPIO_INT(P6)
P6.3	SPIM2C_MISO/ SDIO1	SPIS0B_ MISO/SDIO1			PT_PT3	TIMER_TMR3	GPIO_INT(P6)
P6.4	SPIM2C_SS0	SPIS0B_SSEL			PT_PT4	TIMER_TMR4	GPIO_INT(P6)
P6.5	SPIM2C_SDIO2	SPIS0B_ SDIO2			PT_PT5	TIMER_TMR5	GPIO_INT(P6)
P6.6	SPIM2C_SDIO3	SPIS0B_ SDIO3			PT_PT6	TIMER_TMR0	GPIO_INT(P6)
P6.7	SPIM2C_SR0	I2CM2B/ SE_SDA			PT_PT7	TIMER_TMR1	GPIO_INT(P6)

**Table 1. General-Purpose I/O Matrix (continued)**

	PRIMARY FUNCTION	SECONDARY FUNCTION	TERTIARY FUNCTION	QUATER-NARY FUNCTION	PULSE TRAIN	TIMER INPUT	GPIO INTERRUPT
P7.0	SPIM2C_SS1	I2CM2B/ SE_SCL			PT_PT8	TIMER_TMR2	GPIO_INT(P7)
P7.1	SPIM2C_SS2	I2CM1B/ SD_SDA			PT_PT9	TIMER_TMR3	GPIO_INT(P7)
P7.2	SPIM2C_SR1	I2CM1B/ SD_SCL			PT_PT10	TIMER_TMR4	GPIO_INT(P7)
P7.3	SPIS0C_SCK	I2CM2C/ SG_SDA			PT_PT11	TIMER_TMR5	GPIO_INT(P7)
P7.4	SPIS0C_MOSI/ SDIO0	I2CM2C/ SG_SCL			PT_PT12	TIMER_TMR0	GPIO_INT(P7)
P7.5	SPIS0C_MISO/ SDIO1				PT_PT13	TIMER_TMR1	GPIO_INT(P7)
P7.6	SPIS0C_SS0				PT_PT14	TIMER_TMR2	GPIO_INT(P7)
P7.7	SPIS0C_SDIO2	I2CM1C/ SF_SDA			PT_PT15	TIMER_TMR3	GPIO_INT(P7)
P8.0	SPIS0C_SDIO3	I2CM1C/ SF_SCL			PT_PT0	TIMER_TMR4	GPIO_INT(P8)
P8.1					PT_PT1	TIMER_TMR5	GPIO_INT(P8)

## Ordering Information

PART	FLASH	SRAM	TRUST PROTECTION UNIT (TPU)	PIN-PACKAGE
MAX32630IWG+	2MB	512KB	No	100 WLP
MAX32631IWG+	2MB	512KB	Yes	100 WLP
MAX32630IWG+T	2MB	512KB	No	100 WLP
MAX32631IWG+T	2MB	512KB	Yes	100 WLP

+ Denotes a lead(Pb)-free/RoHS-compliant package.

T = Tape and reel.

## Revision History

REVISION NUMBER	REVISION DATE	DESCRIPTION	PAGES CHANGED
0	3/16	Initial release	—

For pricing, delivery, and ordering information, please contact Maxim Direct at 1-888-629-4642, or visit Maxim Integrated's website at [www.maximintegrated.com](http://www.maximintegrated.com).

*Maxim Integrated cannot assume responsibility for use of any circuitry other than circuitry entirely embodied in a Maxim Integrated product. No circuit patent licenses are implied. Maxim Integrated reserves the right to change the circuitry and specifications without notice at any time. The parametric values (min and max limits) shown in the Electrical Characteristics table are guaranteed. Other parametric values quoted in this data sheet are provided for guidance.*