

Welcome to E-XFL.COM

Understanding [Embedded - Microcontroller, Microprocessor, FPGA Modules](#)

Embedded - Microcontroller, Microprocessor, and FPGA Modules are fundamental components in modern electronic systems, offering a wide range of functionalities and capabilities. Microcontrollers are compact integrated circuits designed to execute specific control tasks within an embedded system. They typically include a processor, memory, and input/output peripherals on a single chip. Microprocessors, on the other hand, are more powerful processing units used in complex computing tasks, often requiring external memory and peripherals. FPGAs (Field Programmable Gate Arrays) are highly flexible devices that can be configured by the user to perform specific logic functions, making them invaluable in applications requiring customization and adaptability.

Applications of [Embedded - Microcontroller,](#)

Details

Product Status	Obsolete
Module/Board Type	MPU Core
Core Processor	ARM® Cortex®-A8, OMAP3530
Co-Processor	-
Speed	600MHz
Flash Size	256MB
RAM Size	128MB
Connector Type	Board-to-Board (BTB) Socket - 200
Size / Dimension	0.59" x 1.06" (15mm x 27mm)
Operating Temperature	0°C ~ 70°C
Purchase URL	https://www.e-xfl.com/product-detail/logic-pd/somomap3530-21-1670agcr

PRODUCT BRIEF:

Logic PD :: Texas Instruments
www.logicpd.com/ti

OMAP35x Torpedo System on Module

:: SUPPORTED PROCESSORS:

OMAP3530
OMAP3503

The Torpedo System on Module (SOM) is an ultra-compact form factor based on Texas Instruments' OMAP 3 processor family.

The OMAP35x Torpedo SOM provides a dime-sized module solution for applications that require low-power and high-performance within tight space constraints. By using the 0.4 mm BGA pitch OMAP processor that leverages Package-on-Package (PoP) technology, the Torpedo SOM requires 45% less surface area and 12% less volume when compared to the equivalent OMAP 0.65 mm BGA package and external memory solution.

A discrete design using the 0.4 mm BGA package requires advanced PCB technologies that result in higher board costs in addition to PoP technology which requires specialized manufacturing assembly processes. The Torpedo SOM solves these development complexities; as a result, customers can design lower cost baseboards and utilize common manufacturing procedures while still benefiting from the small package OMAP35x processor and PoP technology.

The ultra-compact Torpedo SOM is an ideal off-the-shelf solution for applications in markets where space is a premium. From

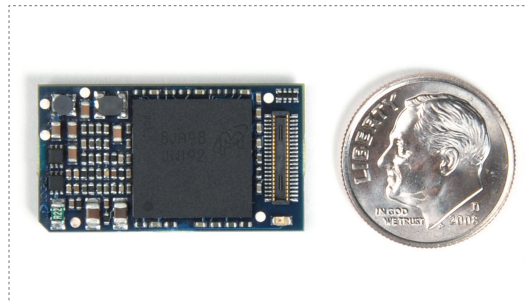

OMAP35x TORPEDO SYSTEM ON MODULE

point-of-care medical devices to bar code readers, handheld radios to mobile Internet devices, netbooks to CCTV cameras, the Torpedo SOM allows for powerful versatility, compact designs, and long-life products.

The Zoom™ OMAP35x Torpedo Development Kit includes all of the necessary accessories to immediately begin development, helping customers deliver their products to market sooner.

OMAP35x TORPEDO SOM :: HIGHLIGHTS:

- +Product-ready System on Module with a TI OMAP35x processor running up to 600 MHz
- +Ultra-compact form factor (15 x 27 x 3.8 mm)
- +Long product lifecycle
- +Microsoft Windows® Embedded CE 6.0 Board Support Packages (BSPs)
- +Open source Linux™ BSP
- +0°C to 70°C (commercial temp) or -40°C to 85°C (industrial temp)
- +RoHS compliant

ZOOM™ OMAP35x TORPEDO DEVELOPMENT KIT :: FEATURES:

- +Application baseboard
- +OMAP3530 Torpedo SOM
- +4.3" WQVGA LCD with 4-wire touchscreen
- +Necessary accessories to immediately get up and running

OMAP35x Torpedo SOM Block Diagram

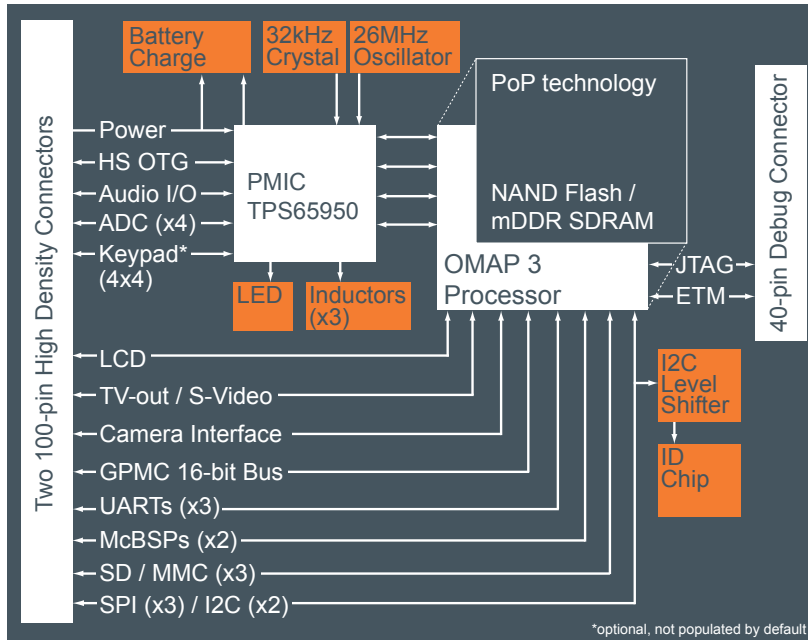

(Block diagram is not drawn to scale. For reference purposes only.)

OMAP35x Torpedo SOM Ordering Information

Model Number	Speed (MHz)	SDRAM (MB)	NAND Flash (MB)	Temperature
SOMOMAP3503-21-1670AGCR	600	128	256	0°C–70°C
SOMOMAP3530-21-1670AGCR	600	128	256	0°C–70°C
SOMOMAP3530-21-1780AGIR	600	256	512	-40°C–85°C

NOTE: Custom configurations are available by special order. Please contact Logic Sales for details: product.sales@logicpd.com.

Zoom™ OMAP35x Torpedo Development Kit Ordering Information

Model Number	SOM Configuration
SDK-OMAP3530-21-128256R	SOMOMAP3530-21-1670AGCR



411 N. Washington Ave. Suite 400 Minneapolis, MN 55401
T : 612.672.9495 F : 612.672.9489 I : www.logicpd.com

LOGIC PD WEBSITE :: DESIGN RESOURCES:

- + Logic PD Products : www.logicpd.com/products
- + Logic PD Technical Support : www.logicpd.com/product-support
- + For more information contact Logic PD Sales : product.sales@logicpd.com

© 2010 Logic Product Development Company. All rights reserved. PN: 1012929 Rev D

Product Features

Processor

- + TI OMAP35x processor running up to 600 MHz

Memory

- + Mobile DDR / NAND flash (PoP technology)
 - 128 MB / 256 MB (standard)
 - 256 MB / 512 MB (standard for I-Temp)

Connectivity

- + Two 100-pin board-to-board connectors
- + Parallel LCD interface
- + USB high-speed On-the-Go interface
- + Multiple SD/MMC card support
- + UARTs, SPI, I2C, McBSPs
- + Parallel camera interface
- + Programmable GPIO
- + TV-out / S-Video interface
- + 40-pin debug connector on top side of SOM
- + Optional 4x4 keypad interface (requires trade-offs with other features)
- + Audio
- + Analog-to-digital converters
- + General purpose memory controller (GPMC) interface
- + JTAG & ETM support

Mechanical

- + 15 mm wide x 27 mm long x 3.8 mm high

RoHS Compliant

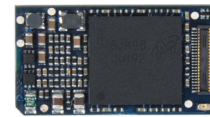

TOP VIEW :: ACTUAL SIZE

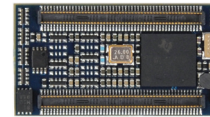

BOTTOM VIEW :: ACTUAL SIZE

