



Welcome to [E-XFL.COM](https://www.e-xfl.com)

Understanding **Embedded - FPGAs (Field Programmable Gate Array)**

Embedded - FPGAs, or Field Programmable Gate Arrays, are advanced integrated circuits that offer unparalleled flexibility and performance for digital systems. Unlike traditional fixed-function logic devices, FPGAs can be programmed and reprogrammed to execute a wide array of logical operations, enabling customized functionality tailored to specific applications. This reprogrammability allows developers to iterate designs quickly and implement complex functions without the need for custom hardware.

Applications of Embedded - FPGAs

The versatility of Embedded - FPGAs makes them indispensable in numerous fields. In telecommunications,

Details

Product Status	Active
Number of LABs/CLBs	160
Number of Logic Elements/Cells	1280
Total RAM Bits	65536
Number of I/O	18
Number of Gates	-
Voltage - Supply	1.14V ~ 1.26V
Mounting Type	Surface Mount
Operating Temperature	-40°C ~ 100°C (TJ)
Package / Case	25-WLCSP
Supplier Device Package	25-WLCSP
Purchase URL	https://www.e-xfl.com/product-detail/lattice-semiconductor/lcmx02-1200ze-1uwg25itr1k

Table 1-1. MachXO2™ Family Selection Guide

		XO2-256	XO2-640	XO2-640U ¹	XO2-1200	XO2-1200U ¹	XO2-2000	XO2-2000U ¹	XO2-4000	XO2-7000
LUTs		256	640	640	1280	1280	2112	2112	4320	6864
Distributed RAM (kbits)		2	5	5	10	10	16	16	34	54
EBR SRAM (kbits)		0	18	64	64	74	74	92	92	240
Number of EBR SRAM Blocks (9 kbits/block)		0	2	7	7	8	8	10	10	26
UFM (kbits)		0	24	64	64	80	80	96	96	256
Device Options:	HC ²	Yes	Yes	Yes	Yes	Yes	Yes	Yes	Yes	Yes
	HE ³						Yes	Yes	Yes	Yes
	ZE ⁴	Yes	Yes		Yes		Yes		Yes	Yes
Number of PLLs		0	0	1	1	1	1	2	2	2
Hardened Functions:	I2C	2	2	2	2	2	2	2	2	2
	SPI	1	1	1	1	1	1	1	1	1
	Timer/Counter	1	1	1	1	1	1	1	1	1
Packages		IO								
25-ball WLCSP ⁵ (2.5 mm x 2.5 mm, 0.4 mm)					18					
32 QFN ⁶ (5 mm x 5 mm, 0.5 mm)		21			21					
48 QFN ^{8,9} (7 mm x 7 mm, 0.5 mm)		40	40							
49-ball WLCSP ⁵ (3.2 mm x 3.2 mm, 0.4 mm)							38			
64-ball ucBGA (4 mm x 4 mm, 0.4 mm)		44								
84 QFN ⁷ (7 mm x 7 mm, 0.5 mm)									68	
100-pin TQFP (14 mm x 14 mm)		55	78		79		79			
132-ball csBGA (8 mm x 8 mm, 0.5 mm)		55	79		104		104		104	
144-pin TQFP (20 mm x 20 mm)				107	107		111		114	114
184-ball csBGA ⁷ (8 mm x 8 mm, 0.5 mm)									150	
256-ball caBGA (14 mm x 14 mm, 0.8 mm)							206		206	206
256-ball ftBGA (17 mm x 17 mm, 1.0 mm)						206	206		206	206
332-ball caBGA (17 mm x 17 mm, 0.8 mm)									274	278
484-ball ftBGA (23 mm x 23 mm, 1.0 mm)								278	278	334

1. Ultra high I/O device.
2. High performance with regulator – VCC = 2.5 V, 3.3 V
3. High performance without regulator – VCC = 1.2 V
4. Low power without regulator – VCC = 1.2 V
5. WLCSP package only available for ZE devices.
6. 32 QFN package only available for HC and ZE devices.
7. 184 csBGA package only available for HE devices.
8. 48-pin QFN information is 'Advanced'.
9. 48 QFN package only available for HC devices.

The logic blocks, Programmable Functional Unit (PFU) and sysMEM EBR blocks, are arranged in a two-dimensional grid with rows and columns. Each row has either the logic blocks or the EBR blocks. The PIO cells are located at the periphery of the device, arranged in banks. The PFU contains the building blocks for logic, arithmetic, RAM, ROM, and register functions. The PIOs utilize a flexible I/O buffer referred to as a sysIO buffer that supports operation with a variety of interface standards. The blocks are connected with many vertical and horizontal routing channel resources. The place and route software tool automatically allocates these routing resources.

In the MachXO2 family, the number of sysIO banks varies by device. There are different types of I/O buffers on the different banks. Refer to the details in later sections of this document. The sysMEM EBRs are large, dedicated fast memory blocks; these blocks are found in MachXO2-640/U and larger devices. These blocks can be configured as RAM, ROM or FIFO. FIFO support includes dedicated FIFO pointer and flag “hard” control logic to minimize LUT usage.

The MachXO2 registers in PFU and sysI/O can be configured to be SET or RESET. After power up and device is configured, the device enters into user mode with these registers SET/RESET according to the configuration setting, allowing device entering to a known state for predictable system function.

The MachXO2 architecture also provides up to two sysCLOCK Phase Locked Loop (PLL) blocks on MachXO2-640U, MachXO2-1200/U and larger devices. These blocks are located at the ends of the on-chip Flash block. The PLLs have multiply, divide, and phase shifting capabilities that are used to manage the frequency and phase relationships of the clocks.

MachXO2 devices provide commonly used hardened functions such as SPI controller, I²C controller and timer/counter. MachXO2-640/U and higher density devices also provide User Flash Memory (UFM). These hardened functions and the UFM interface to the core logic and routing through a WISHBONE interface. The UFM can also be accessed through the SPI, I²C and JTAG ports.

Every device in the family has a JTAG port that supports programming and configuration of the device as well as access to the user logic. The MachXO2 devices are available for operation from 3.3 V, 2.5 V and 1.2 V power supplies, providing easy integration into the overall system.

PFU Blocks

The core of the MachXO2 device consists of PFU blocks, which can be programmed to perform logic, arithmetic, distributed RAM and distributed ROM functions. Each PFU block consists of four interconnected slices numbered 0 to 3 as shown in Figure 2-3. Each slice contains two LUTs and two registers. There are 53 inputs and 25 outputs associated with each PFU block.

Figure 2-4. Slice Diagram

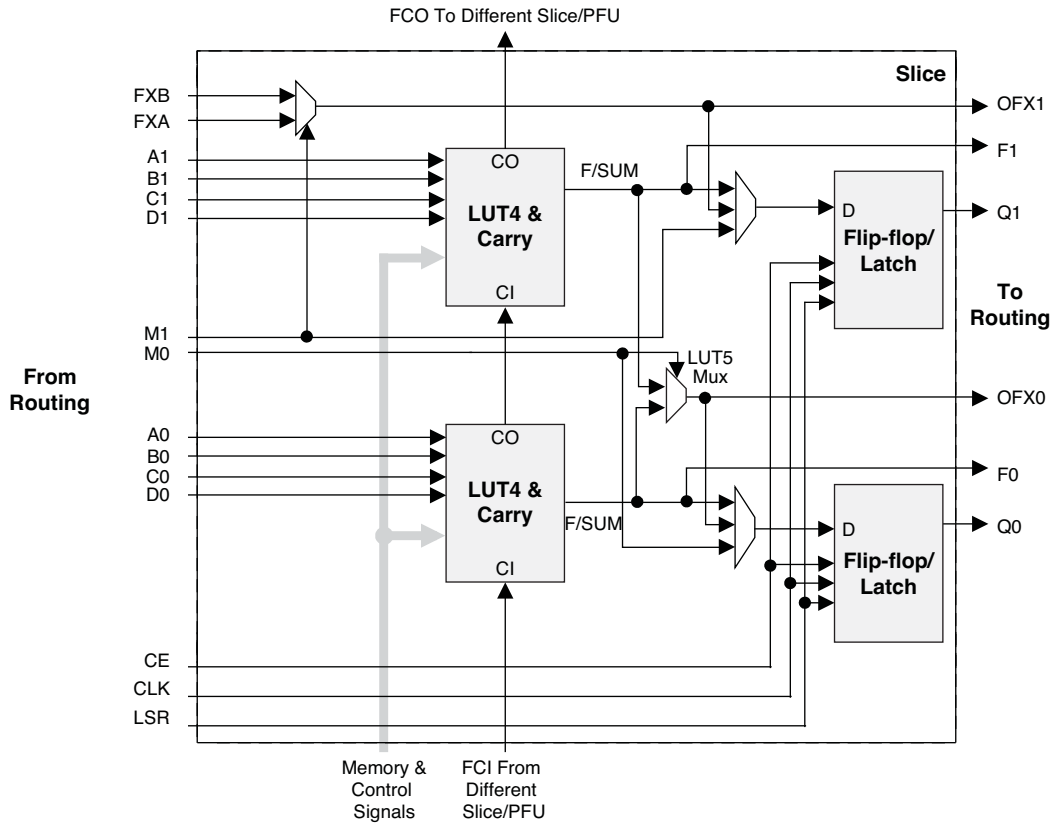

For Slices 0 and 1, memory control signals are generated from Slice 2 as follows:

- WCK is CLK
- WRE is from LSR
- DI[3:2] for Slice 1 and DI[1:0] for Slice 0 data from Slice 2
- WAD [A:D] is a 4-bit address from slice 2 LUT input

Table 2-2. Slice Signal Descriptions

Function	Type	Signal Names	Description
Input	Data signal	A0, B0, C0, D0	Inputs to LUT4
Input	Data signal	A1, B1, C1, D1	Inputs to LUT4
Input	Multi-purpose	M0/M1	Multi-purpose input
Input	Control signal	CE	Clock enable
Input	Control signal	LSR	Local set/reset
Input	Control signal	CLK	System clock
Input	Inter-PFU signal	FCIN	Fast carry in ¹
Output	Data signals	F0, F1	LUT4 output register bypass signals
Output	Data signals	Q0, Q1	Register outputs
Output	Data signals	OFX0	Output of a LUT5 MUX
Output	Data signals	OFX1	Output of a LUT6, LUT7, LUT8 ² MUX depending on the slice
Output	Inter-PFU signal	FCO	Fast carry out ¹

1. See Figure 2-3 for connection details.
2. Requires two PFUs.

Modes of Operation

Each slice has up to four potential modes of operation: Logic, Ripple, RAM and ROM.

Logic Mode

In this mode, the LUTs in each slice are configured as 4-input combinatorial lookup tables. A LUT4 can have 16 possible input combinations. Any four input logic functions can be generated by programming this lookup table. Since there are two LUT4s per slice, a LUT5 can be constructed within one slice. Larger look-up tables such as LUT6, LUT7 and LUT8 can be constructed by concatenating other slices. Note LUT8 requires more than four slices.

Ripple Mode

Ripple mode supports the efficient implementation of small arithmetic functions. In Ripple mode, the following functions can be implemented by each slice:

- Addition 2-bit
- Subtraction 2-bit
- Add/subtract 2-bit using dynamic control
- Up counter 2-bit
- Down counter 2-bit
- Up/down counter with asynchronous clear
- Up/down counter with preload (sync)
- Ripple mode multiplier building block
- Multiplier support
- Comparator functions of A and B inputs
 - A greater-than-or-equal-to B
 - A not-equal-to B
 - A less-than-or-equal-to B

Ripple mode includes an optional configuration that performs arithmetic using fast carry chain methods. In this configuration (also referred to as CCU2 mode) two additional signals, Carry Generate and Carry Propagate, are generated on a per-slice basis to allow fast arithmetic functions to be constructed by concatenating slices.

RAM Mode

In this mode, a 16x4-bit distributed single port RAM (SPR) can be constructed by using each LUT block in Slice 0 and Slice 1 as a 16x1-bit memory. Slice 2 is used to provide memory address and control signals.

MachXO2 devices support distributed memory initialization.

The Lattice design tools support the creation of a variety of different size memories. Where appropriate, the software will construct these using distributed memory primitives that represent the capabilities of the PFU. Table 2-3 shows the number of slices required to implement different distributed RAM primitives. For more information about using RAM in MachXO2 devices, please see TN1201, [Memory Usage Guide for MachXO2 Devices](#).

Table 2-3. Number of Slices Required For Implementing Distributed RAM

	SPR 16x4	PDPR 16x4
Number of slices	3	3

Note: SPR = Single Port RAM, PDPR = Pseudo Dual Port RAM

This phase shift can be either programmed during configuration or can be adjusted dynamically. In dynamic mode, the PLL may lose lock after a phase adjustment on the output used as the feedback source and not relock until the t_{LOCK} parameter has been satisfied.

The MachXO2 also has a feature that allows the user to select between two different reference clock sources dynamically. This feature is implemented using the PLLREFCS primitive. The timing parameters for the PLL are shown in the [sysCLOCK PLL Timing](#) table.

The MachXO2 PLL contains a WISHBONE port feature that allows the PLL settings, including divider values, to be dynamically changed from the user logic. When using this feature the EFB block must also be instantiated in the design to allow access to the WISHBONE ports. Similar to the dynamic phase adjustment, when PLL settings are updated through the WISHBONE port the PLL may lose lock and not relock until the t_{LOCK} parameter has been satisfied. The timing parameters for the PLL are shown in the [sysCLOCK PLL Timing](#) table.

For more details on the PLL and the WISHBONE interface, see TN1199, [MachXO2 sysCLOCK PLL Design and Usage Guide](#).

Figure 2-7. PLL Diagram

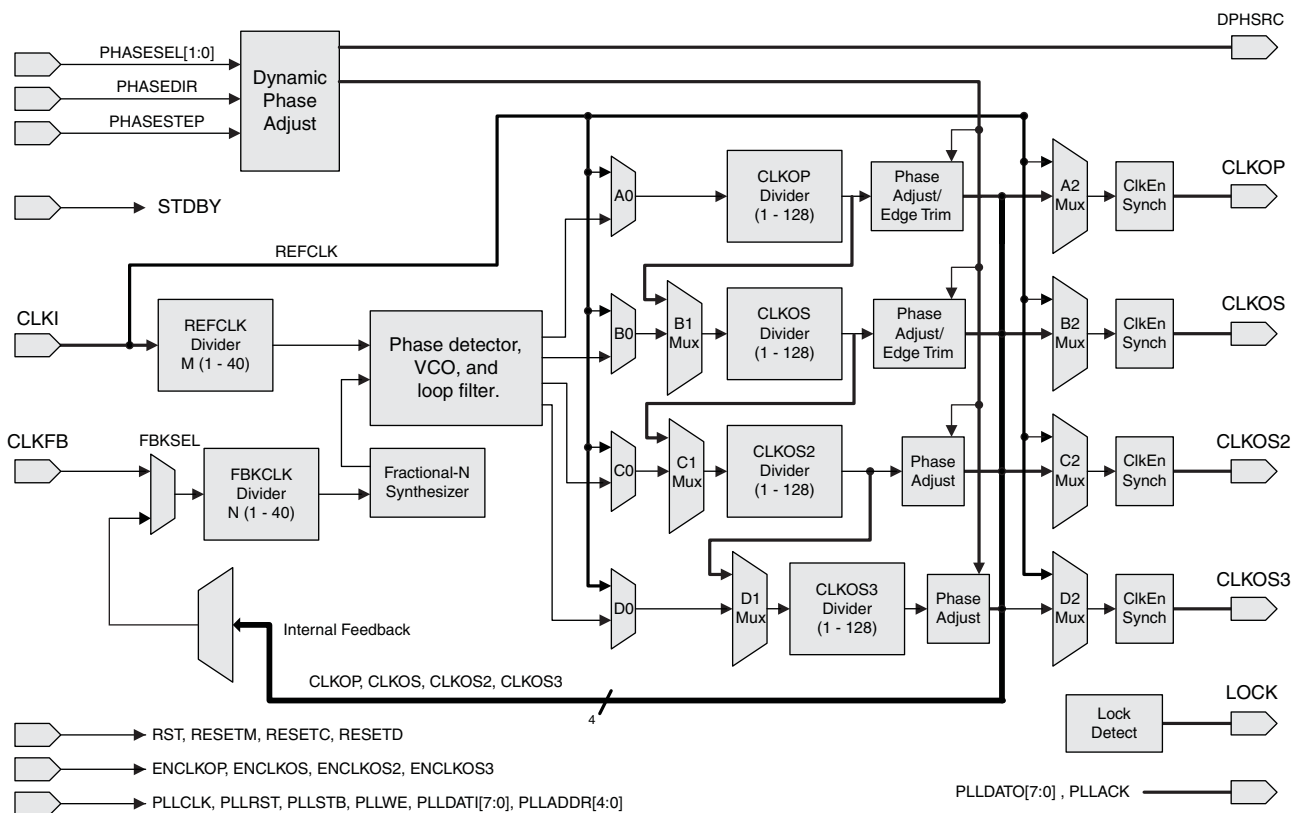

Table 2-4 provides signal descriptions of the PLL block.

Table 2-4. PLL Signal Descriptions

Port Name	I/O	Description
CLKI	I	Input clock to PLL
CLKFB	I	Feedback clock
PHASESEL[1:0]	I	Select which output is affected by Dynamic Phase adjustment ports
PHASEDIR	I	Dynamic Phase adjustment direction
PHASESTEP	I	Dynamic Phase step – toggle shifts VCO phase adjust by one step.

Output Register Block

The output register block registers signals from the core of the device before they are passed to the sysIO buffers.

Left, Top, Bottom Edges

In SDR mode, D0 feeds one of the flip-flops that then feeds the output. The flip-flop can be configured as a D-type register or latch.

In DDR generic mode, D0 and D1 inputs are fed into registers on the positive edge of the clock. At the next falling edge the registered D1 input is registered into the register Q1. A multiplexer running off the same clock is used to switch the mux between the outputs of registers Q0 and Q1 that will then feed the output.

Figure 2-14 shows the output register block on the left, top and bottom edges.

Figure 2-14. MachXO2 Output Register Block Diagram (PIO on the Left, Top and Bottom Edges)

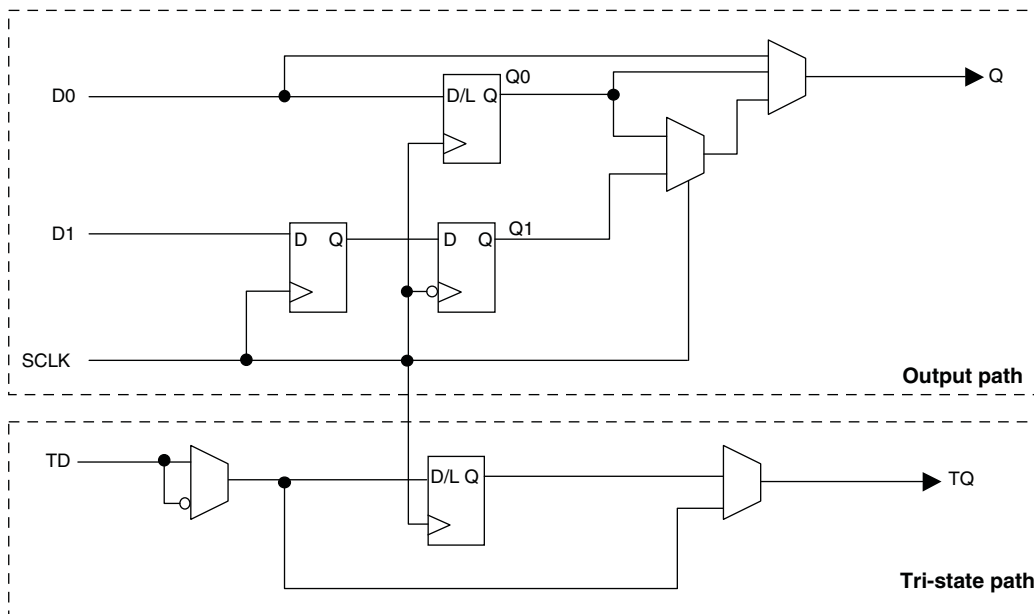

Right Edge

The output register block on the right edge is a superset of the output register on left, top and bottom edges of the device. In addition to supporting SDR and Generic DDR modes, the output register blocks for PIOs on the right edge include additional logic to support DDR-memory interfaces. Operation of this block is similar to that of the output register block on other edges.

In DDR memory mode, D0 and D1 inputs are fed into registers on the positive edge of the clock. At the next falling edge the registered D1 input is registered into the register Q1. A multiplexer running off the DQSW90 signal is used to switch the mux between the outputs of registers Q0 and Q1 that will then feed the output.

Figure 2-15 shows the output register block on the right edge.

Table 2-11. I/O Support Device by Device

	MachXO2-256, MachXO2-640	MachXO2-640U, MachXO2-1200	MachXO2-1200U MachXO2-2000/U, MachXO2-4000, MachXO2-7000
Number of I/O Banks	4	4	6
Type of Input Buffers	Single-ended (all I/O banks) Differential Receivers (all I/O banks)	Single-ended (all I/O banks) Differential Receivers (all I/O banks) Differential input termination (bottom side)	Single-ended (all I/O banks) Differential Receivers (all I/O banks) Differential input termination (bottom side)
Types of Output Buffers	Single-ended buffers with complementary outputs (all I/O banks)	Single-ended buffers with complementary outputs (all I/O banks) Differential buffers with true LVDS outputs (50% on top side)	Single-ended buffers with complementary outputs (all I/O banks) Differential buffers with true LVDS outputs (50% on top side)
Differential Output Emulation Capability	All I/O banks	All I/O banks	All I/O banks
PCI Clamp Support	No	Clamp on bottom side only	Clamp on bottom side only

Table 2-12. Supported Input Standards

Input Standard	VCCIO (Typ.)				
	3.3 V	2.5 V	1.8 V	1.5	1.2 V
Single-Ended Interfaces					
LVTTTL	✓	✓ ²	✓ ²	✓ ²	
LVC MOS33	✓	✓ ²	✓ ²	✓ ²	
LVC MOS25	✓ ²	✓	✓ ²	✓ ²	
LVC MOS18	✓ ²	✓ ²	✓	✓ ²	
LVC MOS15	✓ ²	✓ ²	✓ ²	✓	✓ ²
LVC MOS12	✓ ²	✓ ²	✓ ²	✓ ²	✓
PCI ¹	✓				
SSTL18 (Class I, Class II)	✓	✓	✓		
SSTL25 (Class I, Class II)	✓	✓			
HSTL18 (Class I, Class II)	✓	✓	✓		
Differential Interfaces					
LVDS	✓	✓			
BLVDS, MVDS, LVPECL, RSDS	✓	✓			
MIP1 ³	✓	✓			
Differential SSTL18 Class I, II	✓	✓	✓		
Differential SSTL25 Class I, II	✓	✓			
Differential HSTL18 Class I, II	✓	✓	✓		

1. Bottom banks of MachXO2-640U, MachXO2-1200/U and higher density devices only.
2. Reduced functionality. Refer to TN1202, [MachXO2 sysIO Usage Guide](#) for more detail.
3. These interfaces can be emulated with external resistors in all devices.

Figure 2-18. MachXO2-1200U, MachXO2-2000/U, MachXO2-4000 and MachXO2-7000 Banks

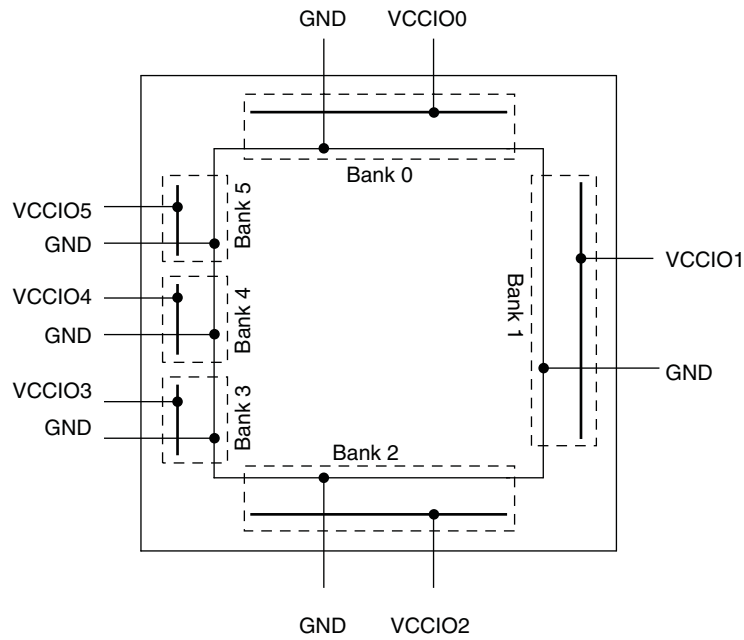
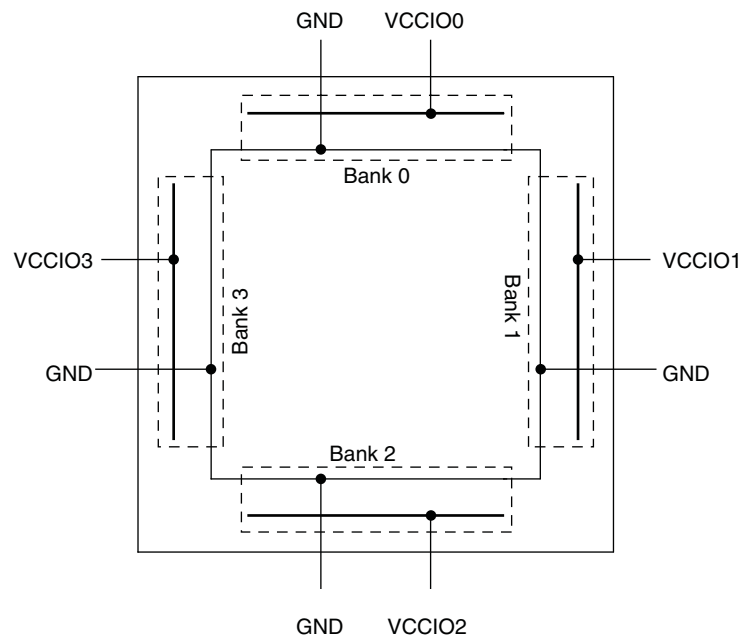

Figure 2-19. MachXO2-256, MachXO2-640/U and MachXO2-1200 Banks



Hardened Timer/Counter

MachXO2 devices provide a hard Timer/Counter IP core. This Timer/Counter is a general purpose, bi-directional, 16-bit timer/counter module with independent output compare units and PWM support. The Timer/Counter supports the following functions:

- Supports the following modes of operation:
 - Watchdog timer
 - Clear timer on compare match
 - Fast PWM
 - Phase and Frequency Correct PWM
- Programmable clock input source
- Programmable input clock prescaler
- One static interrupt output to routing
- One wake-up interrupt to on-chip standby mode controller.
- Three independent interrupt sources: overflow, output compare match, and input capture
- Auto reload
- Time-stamping support on the input capture unit
- Waveform generation on the output
- Glitch-free PWM waveform generation with variable PWM period
- Internal WISHBONE bus access to the control and status registers
- Stand-alone mode with preloaded control registers and direct reset input

Figure 2-23. Timer/Counter Block Diagram

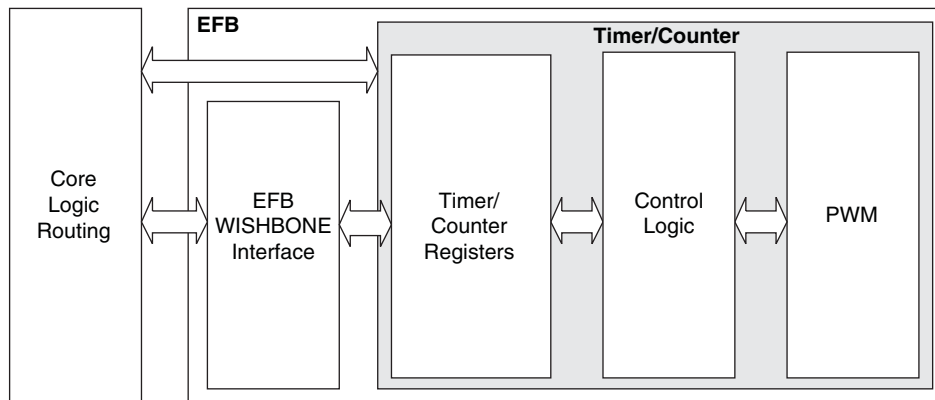

Table 2-17. Timer/Counter Signal Description

Port	I/O	Description
tc_clk	I	Timer/Counter input clock signal
tc_rstn	I	Register tc_rstn_ena is preloaded by configuration to always keep this pin enabled
tc_ic	I	Input capture trigger event, applicable for non-pwm modes with WISHBONE interface. If enabled, a rising edge of this signal will be detected and synchronized to capture tc_cnt value into tc_icr for time-stamping.
tc_int	O	Without WISHBONE – Can be used as overflow flag With WISHBONE – Controlled by three IRQ registers
tc_oc	O	Timer counter output signal

Static Supply Current – HC/HE Devices^{1, 2, 3, 6}

Symbol	Parameter	Device	Typ. ⁴	Units
I _{CC}	Core Power Supply	LCMXO2-256HC	1.15	mA
		LCMXO2-640HC	1.84	mA
		LCMXO2-640UHC	3.48	mA
		LCMXO2-1200HC	3.49	mA
		LCMXO2-1200UHC	4.80	mA
		LCMXO2-2000HC	4.80	mA
		LCMXO2-2000UHC	8.44	mA
		LCMXO2-4000HC	8.45	mA
		LCMXO2-7000HC	12.87	mA
		LCMXO2-2000HE	1.39	mA
		LCMXO2-4000HE	2.55	mA
		LCMXO2-7000HE	4.06	mA
I _{CCIO}	Bank Power Supply ⁵ V _{CCIO} = 2.5 V	All devices	0	mA

- For further information on supply current, please refer to TN1198, [Power Estimation and Management for MachXO2 Devices](#).
- Assumes blank pattern with the following characteristics: all outputs are tri-stated, all inputs are configured as LVCMOS and held at V_{CCIO} or GND, on-chip oscillator is off, on-chip PLL is off.
- Frequency = 0 MHz.
- T_J = 25 °C, power supplies at nominal voltage.
- Does not include pull-up/pull-down.
- To determine the MachXO2 peak start-up current data, use the Power Calculator tool.

Programming and Erase Flash Supply Current – HC/HE Devices^{1, 2, 3, 4}

Symbol	Parameter	Device	Typ. ⁵	Units
I _{CC}	Core Power Supply	LCMXO2-256HC	14.6	mA
		LCMXO2-640HC	16.1	mA
		LCMXO2-640UHC	18.8	mA
		LCMXO2-1200HC	18.8	mA
		LCMXO2-1200UHC	22.1	mA
		LCMXO2-2000HC	22.1	mA
		LCMXO2-2000UHC	26.8	mA
		LCMXO2-4000HC	26.8	mA
		LCMXO2-7000HC	33.2	mA
		LCMXO2-2000HE	18.3	mA
		LCMXO2-2000UHE	20.4	mA
		LCMXO2-4000HE	20.4	mA
		LCMXO2-7000HE	23.9	mA
I _{CCIO}	Bank Power Supply ⁶	All devices	0	mA

- For further information on supply current, please refer to TN1198, [Power Estimation and Management for MachXO2 Devices](#).
- Assumes all inputs are held at V_{CCIO} or GND and all outputs are tri-stated.
- Typical user pattern.
- JTAG programming is at 25 MHz.
- T_J = 25 °C, power supplies at nominal voltage.
- Per bank. V_{CCIO} = 2.5 V. Does not include pull-up/pull-down.

LVPECL

The MachXO2 family supports the differential LVPECL standard through emulation. This output standard is emulated using complementary LVCMOS outputs in conjunction with resistors across the driver outputs on all the devices. The LVPECL input standard is supported by the LVDS differential input buffer. The scheme shown in Differential LVPECL is one possible solution for point-to-point signals.

Figure 3-3. Differential LVPECL

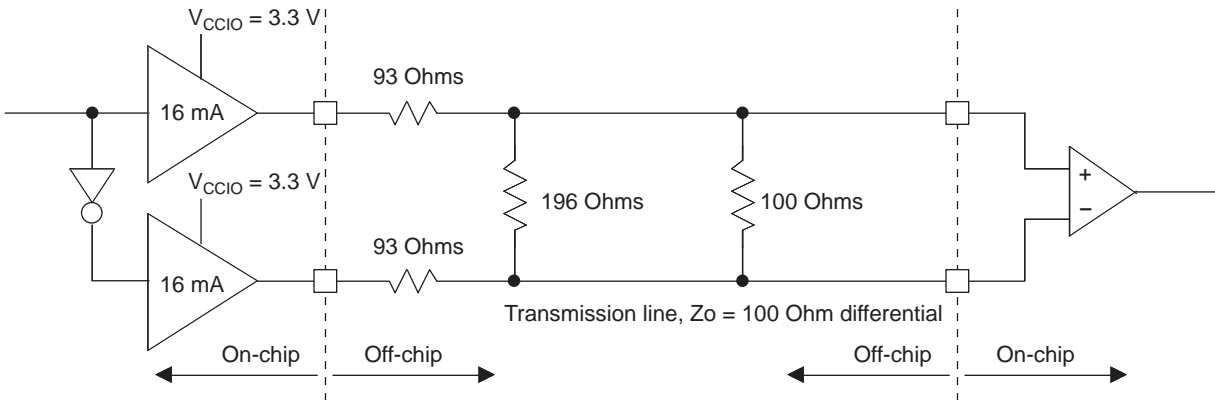

Table 3-3. LVPECL DC Conditions¹

Over Recommended Operating Conditions

Symbol	Description	Nominal	Units
Z _{OUT}	Output impedance	20	Ohms
R _S	Driver series resistor	93	Ohms
R _P	Driver parallel resistor	196	Ohms
R _T	Receiver termination	100	Ohms
V _{OH}	Output high voltage	2.05	V
V _{OL}	Output low voltage	1.25	V
V _{OD}	Output differential voltage	0.80	V
V _{CM}	Output common mode voltage	1.65	V
Z _{BACK}	Back impedance	100.5	Ohms
I _{DC}	DC output current	12.11	mA

1. For input buffer, see LVDS table.

For further information on LVPECL, BLVDS and other differential interfaces please see details of additional technical documentation at the end of the data sheet.

Parameter	Description	Device	-3		-2		-1		Units
			Min.	Max.	Min.	Max.	Min.	Max.	
LPDDR^{9, 12}									
t _{DVADQ}	Input Data Valid After DQS Input	MachXO2-1200/U and larger devices, right side only. ¹³	—	0.349	—	0.381	—	0.396	UI
t _{DVEDQ}	Input Data Hold After DQS Input		0.665	—	0.630	—	0.613	—	UI
t _{DQVBS}	Output Data Invalid Before DQS Output		0.25	—	0.25	—	0.25	—	UI
t _{DQVAS}	Output Data Invalid After DQS Output		0.25	—	0.25	—	0.25	—	UI
f _{DATA}	MEM LPDDR Serial Data Speed		—	120	—	110	—	96	Mbps
f _{SCLK}	SCLK Frequency		—	60	—	55	—	48	MHz
f _{LPDDR}	LPDDR Data Transfer Rate		0	120	0	110	0	96	Mbps
DDR^{9, 12}									
t _{DVADQ}	Input Data Valid After DQS Input	MachXO2-1200/U and larger devices, right side only. ¹³	—	0.347	—	0.374	—	0.393	UI
t _{DVEDQ}	Input Data Hold After DQS Input		0.665	—	0.637	—	0.616	—	UI
t _{DQVBS}	Output Data Invalid Before DQS Output		0.25	—	0.25	—	0.25	—	UI
t _{DQVAS}	Output Data Invalid After DQS Output		0.25	—	0.25	—	0.25	—	UI
f _{DATA}	MEM DDR Serial Data Speed		—	140	—	116	—	98	Mbps
f _{SCLK}	SCLK Frequency		—	70	—	58	—	49	MHz
f _{MEM_DDR}	MEM DDR Data Transfer Rate		N/A	140	N/A	116	N/A	98	Mbps
DDR2^{9, 12}									
t _{DVADQ}	Input Data Valid After DQS Input	MachXO2-1200/U and larger devices, right side only. ¹³	—	0.372	—	0.394	—	0.410	UI
t _{DVEDQ}	Input Data Hold After DQS Input		0.690	—	0.658	—	0.618	—	UI
t _{DQVBS}	Output Data Invalid Before DQS Output		0.25	—	0.25	—	0.25	—	UI
t _{DQVAS}	Output Data Invalid After DQS Output		0.25	—	0.25	—	0.25	—	UI
f _{DATA}	MEM DDR Serial Data Speed		—	140	—	116	—	98	Mbps
f _{SCLK}	SCLK Frequency		—	70	—	58	—	49	MHz
f _{MEM_DDR2}	MEM DDR2 Data Transfer Rate		N/A	140	N/A	116	N/A	98	Mbps

1. Exact performance may vary with device and design implementation. Commercial timing numbers are shown at 85 °C and 1.14 V. Other operating conditions, including industrial, can be extracted from the Diamond software.
2. General I/O timing numbers based on LVCMOS 2.5, 8 mA, 0 pf load, fast slew rate.
3. Generic DDR timing numbers based on LVDS I/O (for input, output, and clock ports).
4. DDR timing numbers based on SSTL25. DDR2 timing numbers based on SSTL18. LPDDR timing numbers based in LVCMOS18.
5. 7:1 LVDS (GDDR71) uses the LVDS I/O standard (for input, output, and clock ports).
6. For Generic DDRX1 mode $t_{SU} = t_{HO} = (t_{DVE} - t_{DVA} - 0.03 \text{ ns})/2$.
7. The t_{SU_DEL} and t_{H_DEL} values use the SCLK_ZERHOLD default step size. Each step is 167 ps (-3), 182 ps (-2), 195 ps (-1).
8. This number for general purpose usage. Duty cycle tolerance is +/-10%.
9. Duty cycle is +/- 5% for system usage.
10. The above timing numbers are generated using the Diamond design tool. Exact performance may vary with the device selected.
11. High-speed DDR and LVDS not supported in SG32 (32-Pin QFN) packages.
12. Advance information for MachXO2 devices in 48 QFN packages.
13. DDR memory interface not supported in QN84 (84 QFN) and SG32 (32 QFN) packages.

sysCLOCK PLL Timing

Over Recommended Operating Conditions

Parameter	Descriptions	Conditions	Min.	Max.	Units
f_{IN}	Input Clock Frequency (CLKI, CLKFB)		7	400	MHz
f_{OUT}	Output Clock Frequency (CLKOP, CLKOS, CLKOS2)		1.5625	400	MHz
f_{OUT2}	Output Frequency (CLKOS3 cascaded from CLKOS2)		0.0122	400	MHz
f_{VCO}	PLL VCO Frequency		200	800	MHz
f_{PFD}	Phase Detector Input Frequency		7	400	MHz
AC Characteristics					
t_{DT}	Output Clock Duty Cycle	Without duty trim selected ³	45	55	%
$t_{DT_TRIM}^7$	Edge Duty Trim Accuracy		-75	75	%
t_{PH}^4	Output Phase Accuracy		-6	6	%
$t_{OPJIT}^{1,8}$	Output Clock Period Jitter	$f_{OUT} > 100$ MHz	—	150	ps p-p
		$f_{OUT} < 100$ MHz	—	0.007	UIPP
	Output Clock Cycle-to-cycle Jitter	$f_{OUT} > 100$ MHz	—	180	ps p-p
		$f_{OUT} < 100$ MHz	—	0.009	UIPP
	Output Clock Phase Jitter	$f_{PFD} > 100$ MHz	—	160	ps p-p
		$f_{PFD} < 100$ MHz	—	0.011	UIPP
	Output Clock Period Jitter (Fractional-N)	$f_{OUT} > 100$ MHz	—	230	ps p-p
		$f_{OUT} < 100$ MHz	—	0.12	UIPP
Output Clock Cycle-to-cycle Jitter (Fractional-N)	$f_{OUT} > 100$ MHz	—	230	ps p-p	
	$f_{OUT} < 100$ MHz	—	0.12	UIPP	
t_{SPO}	Static Phase Offset	Divider ratio = integer	-120	120	ps
t_W	Output Clock Pulse Width	At 90% or 10% ³	0.9	—	ns
$t_{LOCK}^{2,5}$	PLL Lock-in Time		—	15	ms
t_{UNLOCK}	PLL Unlock Time		—	50	ns
t_{IPJIT}^6	Input Clock Period Jitter	$f_{PFD} \geq 20$ MHz	—	1,000	ps p-p
		$f_{PFD} < 20$ MHz	—	0.02	UIPP
t_{HI}	Input Clock High Time	90% to 90%	0.5	—	ns
t_{LO}	Input Clock Low Time	10% to 10%	0.5	—	ns
t_{STABLE}^5	STANDBY High to PLL Stable		—	15	ms
t_{RST}	RST/RESETM Pulse Width		1	—	ns
t_{RSTREC}	RST Recovery Time		1	—	ns
t_{RST_DIV}	RESETC/D Pulse Width		10	—	ns
t_{RSTREC_DIV}	RESETC/D Recovery Time		1	—	ns
$t_{ROTATE-SETUP}$	PHASESTEP Setup Time		10	—	ns

Pinout Information Summary

	MachXO2-256					MachXO2-640			MachXO2-640U
	32 QFN ¹	48 QFN ³	64 ucBGA	100 TQFP	132 csBGA	48 QFN ³	100 TQFP	132 csBGA	144 TQFP
General Purpose I/O per Bank									
Bank 0	8	10	9	13	13	10	18	19	27
Bank 1	2	10	12	14	14	10	20	20	26
Bank 2	9	10	11	14	14	10	20	20	28
Bank 3	2	10	12	14	14	10	20	20	26
Bank 4	0	0	0	0	0	0	0	0	0
Bank 5	0	0	0	0	0	0	0	0	0
Total General Purpose Single Ended I/O	21	40	44	55	55	40	78	79	107
Differential I/O per Bank									
Bank 0	4	5	5	7	7	5	9	10	14
Bank 1	1	5	6	7	7	5	10	10	13
Bank 2	4	5	5	7	7	5	10	10	14
Bank 3	1	5	6	7	7	5	10	10	13
Bank 4	0	0	0	0	0	0	0	0	0
Bank 5	0	0	0	0	0	0	0	0	0
Total General Purpose Differential I/O	10	20	22	28	28	20	39	40	54
Dual Function I/O	22	25	27	29	29	25	29	29	33
High-speed Differential I/O									
Bank 0	0	0	0	0	0	0	0	0	7
Gearboxes									
Number of 7:1 or 8:1 Output Gearbox Available (Bank 0)	0	0	0	0	0	0	0	0	7
Number of 7:1 or 8:1 Input Gearbox Available (Bank 2)	0	0	0	0	0	0	0	0	7
DQS Groups									
Bank 1	0	0	0	0	0	0	0	0	2
VCCIO Pins									
Bank 0	2	2	2	2	2	2	2	2	3
Bank 1	1	1	2	2	2	1	2	2	3
Bank 2	2	2	2	2	2	2	2	2	3
Bank 3	1	1	2	2	2	1	2	2	3
Bank 4	0	0	0	0	0	0	0	0	0
Bank 5	0	0	0	0	0	0	0	0	0
VCC	2	2	2	2	2	2	2	2	4
GND ²	2	1	8	8	8	1	8	10	12
NC	0	0	1	26	58	0	3	32	8
Reserved for Configuration	1	1	1	1	1	1	1	1	1
Total Count of Bonded Pins	32	49	64	100	132	49	100	132	144

1. Lattice recommends soldering the central thermal pad onto the top PCB ground for improved thermal resistance.
2. For 48 QFN package, exposed die pad is the device ground.
3. 48-pin QFN information is 'Advanced'.

	MachXO2-4000							
	84 QFN	132 csBGA	144 TQFP	184 csBGA	256 caBGA	256 ftBGA	332 caBGA	484 fpBGA
General Purpose I/O per Bank								
Bank 0	27	25	27	37	50	50	68	70
Bank 1	10	26	29	37	52	52	68	68
Bank 2	22	28	29	39	52	52	70	72
Bank 3	0	7	9	10	16	16	24	24
Bank 4	9	8	10	12	16	16	16	16
Bank 5	0	10	10	15	20	20	28	28
Total General Purpose Single Ended I/O	68	104	114	150	206	206	274	278
Differential I/O per Bank								
Bank 0	13	13	14	18	25	25	34	35
Bank 1	4	13	14	18	26	26	34	34
Bank 2	11	14	14	19	26	26	35	36
Bank 3	0	3	4	4	8	8	12	12
Bank 4	4	4	5	6	8	8	8	8
Bank 5	0	5	5	7	10	10	14	14
Total General Purpose Differential I/O	32	52	56	72	103	103	137	139
Dual Function I/O								
	28	37	37	37	37	37	37	37
High-speed Differential I/O								
Bank 0	8	8	9	8	18	18	18	18
Gearboxes								
Number of 7:1 or 8:1 Output Gearbox Available (Bank 0)	8	8	9	9	18	18	18	18
Number of 7:1 or 8:1 Input Gearbox Available (Bank 2)	11	14	14	12	18	18	18	18
DQS Groups								
Bank 1	1	2	2	2	2	2	2	2
VCCIO Pins								
Bank 0	3	3	3	3	4	4	4	10
Bank 1	1	3	3	3	4	4	4	10
Bank 2	2	3	3	3	4	4	4	10
Bank 3	1	1	1	1	1	1	2	3
Bank 4	1	1	1	1	2	2	1	4
Bank 5	1	1	1	1	1	1	2	3
VCC	4	4	4	4	8	8	8	12
GND	4	10	12	16	24	24	27	48
NC	1	1	1	1	1	1	5	105
Reserved for configuration	1	1	1	1	1	1	1	1
Total Count of Bonded Pins	84	132	144	184	256	256	332	484

Part Number	LUTs	Supply Voltage	Grade	Package	Leads	Temp.
LCMXO2-2000ZE-1TG100C	2112	1.2 V	-1	Halogen-Free TQFP	100	COM
LCMXO2-2000ZE-2TG100C	2112	1.2 V	-2	Halogen-Free TQFP	100	COM
LCMXO2-2000ZE-3TG100C	2112	1.2 V	-3	Halogen-Free TQFP	100	COM
LCMXO2-2000ZE-1MG132C	2112	1.2 V	-1	Halogen-Free csBGA	132	COM
LCMXO2-2000ZE-2MG132C	2112	1.2 V	-2	Halogen-Free csBGA	132	COM
LCMXO2-2000ZE-3MG132C	2112	1.2 V	-3	Halogen-Free csBGA	132	COM
LCMXO2-2000ZE-1TG144C	2112	1.2 V	-1	Halogen-Free TQFP	144	COM
LCMXO2-2000ZE-2TG144C	2112	1.2 V	-2	Halogen-Free TQFP	144	COM
LCMXO2-2000ZE-3TG144C	2112	1.2 V	-3	Halogen-Free TQFP	144	COM
LCMXO2-2000ZE-1BG256C	2112	1.2 V	-1	Halogen-Free caBGA	256	COM
LCMXO2-2000ZE-2BG256C	2112	1.2 V	-2	Halogen-Free caBGA	256	COM
LCMXO2-2000ZE-3BG256C	2112	1.2 V	-3	Halogen-Free caBGA	256	COM
LCMXO2-2000ZE-1FTG256C	2112	1.2 V	-1	Halogen-Free ftBGA	256	COM
LCMXO2-2000ZE-2FTG256C	2112	1.2 V	-2	Halogen-Free ftBGA	256	COM
LCMXO2-2000ZE-3FTG256C	2112	1.2 V	-3	Halogen-Free ftBGA	256	COM

Part Number	LUTs	Supply Voltage	Grade	Package	Leads	Temp.
LCMXO2-4000ZE-1QN84C	4320	1.2 V	-1	Halogen-Free QFN	84	COM
LCMXO2-4000ZE-2QN84C	4320	1.2 V	-2	Halogen-Free QFN	84	COM
LCMXO2-4000ZE-3QN84C	4320	1.2 V	-3	Halogen-Free QFN	84	COM
LCMXO2-4000ZE-1MG132C	4320	1.2 V	-1	Halogen-Free csBGA	132	COM
LCMXO2-4000ZE-2MG132C	4320	1.2 V	-2	Halogen-Free csBGA	132	COM
LCMXO2-4000ZE-3MG132C	4320	1.2 V	-3	Halogen-Free csBGA	132	COM
LCMXO2-4000ZE-1TG144C	4320	1.2 V	-1	Halogen-Free TQFP	144	COM
LCMXO2-4000ZE-2TG144C	4320	1.2 V	-2	Halogen-Free TQFP	144	COM
LCMXO2-4000ZE-3TG144C	4320	1.2 V	-3	Halogen-Free TQFP	144	COM
LCMXO2-4000ZE-1BG256C	4320	1.2 V	-1	Halogen-Free caBGA	256	COM
LCMXO2-4000ZE-2BG256C	4320	1.2 V	-2	Halogen-Free caBGA	256	COM
LCMXO2-4000ZE-3BG256C	4320	1.2 V	-3	Halogen-Free caBGA	256	COM
LCMXO2-4000ZE-1FTG256C	4320	1.2 V	-1	Halogen-Free ftBGA	256	COM
LCMXO2-4000ZE-2FTG256C	4320	1.2 V	-2	Halogen-Free ftBGA	256	COM
LCMXO2-4000ZE-3FTG256C	4320	1.2 V	-3	Halogen-Free ftBGA	256	COM
LCMXO2-4000ZE-1BG332C	4320	1.2 V	-1	Halogen-Free caBGA	332	COM
LCMXO2-4000ZE-2BG332C	4320	1.2 V	-2	Halogen-Free caBGA	332	COM
LCMXO2-4000ZE-3BG332C	4320	1.2 V	-3	Halogen-Free caBGA	332	COM
LCMXO2-4000ZE-1FG484C	4320	1.2 V	-1	Halogen-Free fpBGA	484	COM
LCMXO2-4000ZE-2FG484C	4320	1.2 V	-2	Halogen-Free fpBGA	484	COM
LCMXO2-4000ZE-3FG484C	4320	1.2 V	-3	Halogen-Free fpBGA	484	COM

Part Number	LUTs	Supply Voltage	Grade	Package	Leads	Temp.
LCMXO2-4000HE-6BG332C	4320	1.2 V	-6	Halogen-Free caBGA	332	COM
LCMXO2-4000HE-4FG484C	4320	1.2 V	-4	Halogen-Free fpBGA	484	COM
LCMXO2-4000HE-5FG484C	4320	1.2 V	-5	Halogen-Free fpBGA	484	COM
LCMXO2-4000HE-6FG484C	4320	1.2 V	-6	Halogen-Free fpBGA	484	COM

Part Number	LUTs	Supply Voltage	Grade	Package	Leads	Temp.
LCMXO2-7000HE-4TG144C	6864	1.2 V	-4	Halogen-Free TQFP	144	COM
LCMXO2-7000HE-5TG144C	6864	1.2 V	-5	Halogen-Free TQFP	144	COM
LCMXO2-7000HE-6TG144C	6864	1.2 V	-6	Halogen-Free TQFP	144	COM
LCMXO2-7000HE-4BG256C	6864	1.2 V	-4	Halogen-Free caBGA	256	COM
LCMXO2-7000HE-5BG256C	6864	1.2 V	-5	Halogen-Free caBGA	256	COM
LCMXO2-7000HE-6BG256C	6864	1.2 V	-6	Halogen-Free caBGA	256	COM
LCMXO2-7000HE-4FTG256C	6864	1.2 V	-4	Halogen-Free ftBGA	256	COM
LCMXO2-7000HE-5FTG256C	6864	1.2 V	-5	Halogen-Free ftBGA	256	COM
LCMXO2-7000HE-6FTG256C	6864	1.2 V	-6	Halogen-Free ftBGA	256	COM
LCMXO2-7000HE-4BG332C	6864	1.2 V	-4	Halogen-Free caBGA	332	COM
LCMXO2-7000HE-5BG332C	6864	1.2 V	-5	Halogen-Free caBGA	332	COM
LCMXO2-7000HE-6BG332C	6864	1.2 V	-6	Halogen-Free caBGA	332	COM
LCMXO2-7000HE-4FG484C	6864	1.2 V	-4	Halogen-Free fpBGA	484	COM
LCMXO2-7000HE-5FG484C	6864	1.2 V	-5	Halogen-Free fpBGA	484	COM
LCMXO2-7000HE-6FG484C	6864	1.2 V	-6	Halogen-Free fpBGA	484	COM

Part Number	LUTs	Supply Voltage	Grade	Package	Leads	Temp.
LCMXO2-4000ZE-1QN84I	4320	1.2 V	-1	Halogen-Free QFN	84	IND
LCMXO2-4000ZE-2QN84I	4320	1.2 V	-2	Halogen-Free QFN	84	IND
LCMXO2-4000ZE-3QN84I	4320	1.2 V	-3	Halogen-Free QFN	84	IND
LCMXO2-4000ZE-1MG132I	4320	1.2 V	-1	Halogen-Free csBGA	132	IND
LCMXO2-4000ZE-2MG132I	4320	1.2 V	-2	Halogen-Free csBGA	132	IND
LCMXO2-4000ZE-3MG132I	4320	1.2 V	-3	Halogen-Free csBGA	132	IND
LCMXO2-4000ZE-1TG144I	4320	1.2 V	-1	Halogen-Free TQFP	144	IND
LCMXO2-4000ZE-2TG144I	4320	1.2 V	-2	Halogen-Free TQFP	144	IND
LCMXO2-4000ZE-3TG144I	4320	1.2 V	-3	Halogen-Free TQFP	144	IND
LCMXO2-4000ZE-1BG256I	4320	1.2 V	-1	Halogen-Free caBGA	256	IND
LCMXO2-4000ZE-2BG256I	4320	1.2 V	-2	Halogen-Free caBGA	256	IND
LCMXO2-4000ZE-3BG256I	4320	1.2 V	-3	Halogen-Free caBGA	256	IND
LCMXO2-4000ZE-1FTG256I	4320	1.2 V	-1	Halogen-Free ftBGA	256	IND
LCMXO2-4000ZE-2FTG256I	4320	1.2 V	-2	Halogen-Free ftBGA	256	IND
LCMXO2-4000ZE-3FTG256I	4320	1.2 V	-3	Halogen-Free ftBGA	256	IND
LCMXO2-4000ZE-1BG332I	4320	1.2 V	-1	Halogen-Free caBGA	332	IND
LCMXO2-4000ZE-2BG332I	4320	1.2 V	-2	Halogen-Free caBGA	332	IND
LCMXO2-4000ZE-3BG332I	4320	1.2 V	-3	Halogen-Free caBGA	332	IND
LCMXO2-4000ZE-1FG484I	4320	1.2 V	-1	Halogen-Free fpBGA	484	IND
LCMXO2-4000ZE-2FG484I	4320	1.2 V	-2	Halogen-Free fpBGA	484	IND
LCMXO2-4000ZE-3FG484I	4320	1.2 V	-3	Halogen-Free fpBGA	484	IND

Part Number	LUTs	Supply Voltage	Grade	Package	Leads	Temp.
LCMXO2-7000ZE-1TG144I	6864	1.2 V	-1	Halogen-Free TQFP	144	IND
LCMXO2-7000ZE-2TG144I	6864	1.2 V	-2	Halogen-Free TQFP	144	IND
LCMXO2-7000ZE-3TG144I	6864	1.2 V	-3	Halogen-Free TQFP	144	IND
LCMXO2-7000ZE-1BG256I	6864	1.2 V	-1	Halogen-Free caBGA	256	IND
LCMXO2-7000ZE-2BG256I	6864	1.2 V	-2	Halogen-Free caBGA	256	IND
LCMXO2-7000ZE-3BG256I	6864	1.2 V	-3	Halogen-Free caBGA	256	IND
LCMXO2-7000ZE-1FTG256I	6864	1.2 V	-1	Halogen-Free ftBGA	256	IND
LCMXO2-7000ZE-2FTG256I	6864	1.2 V	-2	Halogen-Free ftBGA	256	IND
LCMXO2-7000ZE-3FTG256I	6864	1.2 V	-3	Halogen-Free ftBGA	256	IND
LCMXO2-7000ZE-1BG332I	6864	1.2 V	-1	Halogen-Free caBGA	332	IND
LCMXO2-7000ZE-2BG332I	6864	1.2 V	-2	Halogen-Free caBGA	332	IND
LCMXO2-7000ZE-3BG332I	6864	1.2 V	-3	Halogen-Free caBGA	332	IND
LCMXO2-7000ZE-1FG484I	6864	1.2 V	-1	Halogen-Free fpBGA	484	IND
LCMXO2-7000ZE-2FG484I	6864	1.2 V	-2	Halogen-Free fpBGA	484	IND
LCMXO2-7000ZE-3FG484I	6864	1.2 V	-3	Halogen-Free fpBGA	484	IND

Part Number	LUTs	Supply Voltage	Grade	Package	Leads	Temp.
LCMXO2-1200ZE-1TG100IR1 ¹	1280	1.2 V	-1	Halogen-Free TQFP	100	IND
LCMXO2-1200ZE-2TG100IR1 ¹	1280	1.2 V	-2	Halogen-Free TQFP	100	IND
LCMXO2-1200ZE-3TG100IR1 ¹	1280	1.2 V	-3	Halogen-Free TQFP	100	IND
LCMXO2-1200ZE-1MG132IR1 ¹	1280	1.2 V	-1	Halogen-Free csBGA	132	IND
LCMXO2-1200ZE-2MG132IR1 ¹	1280	1.2 V	-2	Halogen-Free csBGA	132	IND
LCMXO2-1200ZE-3MG132IR1 ¹	1280	1.2 V	-3	Halogen-Free csBGA	132	IND
LCMXO2-1200ZE-1TG144IR1 ¹	1280	1.2 V	-1	Halogen-Free TQFP	144	IND
LCMXO2-1200ZE-2TG144IR1 ¹	1280	1.2 V	-2	Halogen-Free TQFP	144	IND
LCMXO2-1200ZE-3TG144IR1 ¹	1280	1.2 V	-3	Halogen-Free TQFP	144	IND

1. Specifications for the “LCMXO2-1200ZE-speed package IR1” are the same as the “LCMXO2-1200ZE-speed package I” devices respectively, except as specified in the [R1 Device Specifications](#) section of this data sheet.

Date	Version	Section	Change Summary
February 2012	01.7	All	Updated document with new corporate logo.
		01.6	Data sheet status changed from preliminary to final.
	DC and Switching Characteristics	Introduction	MachXO2 Family Selection Guide table – Removed references to 49-ball WLCSP.
		Updated Flash Download Time table.	
		Modified Storage Temperature in the Absolute Maximum Ratings section.	
		Updated I _{DK} max in Hot Socket Specifications table.	
		Modified Static Supply Current tables for ZE and HC/HE devices.	
		Updated Power Supply Ramp Rates table.	
		Updated Programming and Erase Supply Current tables.	
		Updated data in the External Switching Characteristics table.	
		Corrected Absolute Maximum Ratings for Dedicated Input Voltage Applied for LCMXO2 HC.	
		DC Electrical Characteristics table – Minor corrections to conditions for I _{IL} , I _{IH} .	
	Pinout Information	Removed references to 49-ball WLCSP.	
Signal Descriptions table – Updated description for GND, VCC, and VCCIOx.			
Updated Pin Information Summary table – Number of VCCIOs, GNDs, VCCs, and Total Count of Bonded Pins for MachXO2-256, 640, and 640U and Dual Function I/O for MachXO2-4000 332caBGA.			
Ordering Information	Removed references to 49-ball WLCSP		
August 2011	01.5	DC and Switching Characteristics	Updated ESD information.
		Ordering Information	Updated footnote for ordering WLCSP devices.
	01.4	Architecture	Updated information in Clock/Control Distribution Network and sys-CLOCK Phase Locked Loops (PLLs).
		DC and Switching Characteristics	Updated I _{IL} and I _{IH} conditions in the DC Electrical Characteristics table.
		Pinout Information	Included number of 7:1 and 8:1 gearboxes (input and output) in the pin information summary tables.
			Updated Pin Information Summary table: Dual Function I/O, DQS Groups Bank 1, Total General Purpose Single-Ended I/O, Differential I/O Per Bank, Total Count of Bonded Pins, Gearboxes.
			Added column of data for MachXO2-2000 49 WLCSP.
		Ordering Information	Updated R1 Device Specifications text section with information on migration from MachXO2-1200-R1 to Standard (non-R1) devices.
			Corrected Supply Voltage typo for part numbers: LCMX02-2000UHE-4FG484I, LCMX02-2000UHE-5FG484I, LCMX02-2000UHE-6FG484I.
			Added footnote for WLCSP package parts.
Supplemental Information	Removed reference to Stand-alone Power Calculator for MachXO2 Devices. Added reference to AN8086, Designing for Migration from MachXO2-1200-R1 to Standard (non-R1) Devices.		