

Welcome to [E-XFL.COM](https://www.e-xfl.com)

Understanding [Embedded - FPGAs \(Field Programmable Gate Array\)](#)

Embedded - FPGAs, or Field Programmable Gate Arrays, are advanced integrated circuits that offer unparalleled flexibility and performance for digital systems. Unlike traditional fixed-function logic devices, FPGAs can be programmed and reprogrammed to execute a wide array of logical operations, enabling customized functionality tailored to specific applications. This reprogrammability allows developers to iterate designs quickly and implement complex functions without the need for custom hardware.

Applications of Embedded - FPGAs

The versatility of Embedded - FPGAs makes them indispensable in numerous fields. In telecommunications,

Details

Product Status	Active
Number of LABs/CLBs	264
Number of Logic Elements/Cells	2112
Total RAM Bits	75776
Number of I/O	206
Number of Gates	-
Voltage - Supply	2.375V ~ 3.465V
Mounting Type	Surface Mount
Operating Temperature	-40°C ~ 100°C (Tj)
Package / Case	256-LFBGA
Supplier Device Package	256-CABGA (14x14)
Purchase URL	https://www.e-xfl.com/product-detail/lattice-semiconductor/lcmx02-2000hc-4bg256i

Introduction

The MachXO2 family of ultra low power, instant-on, non-volatile PLDs has six devices with densities ranging from 256 to 6864 Look-Up Tables (LUTs). In addition to LUT-based, low-cost programmable logic these devices feature Embedded Block RAM (EBR), Distributed RAM, User Flash Memory (UFM), Phase Locked Loops (PLLs), pre-engineered source synchronous I/O support, advanced configuration support including dual-boot capability and hardened versions of commonly used functions such as SPI controller, I²C controller and timer/counter. These features allow these devices to be used in low cost, high volume consumer and system applications.

The MachXO2 devices are designed on a 65 nm non-volatile low power process. The device architecture has several features such as programmable low swing differential I/Os and the ability to turn off I/O banks, on-chip PLLs and oscillators dynamically. These features help manage static and dynamic power consumption resulting in low static power for all members of the family.

The MachXO2 devices are available in two versions – ultra low power (ZE) and high performance (HC and HE) devices. The ultra low power devices are offered in three speed grades –1, –2 and –3, with –3 being the fastest. Similarly, the high-performance devices are offered in three speed grades: –4, –5 and –6, with –6 being the fastest. HC devices have an internal linear voltage regulator which supports external V_{CC} supply voltages of 3.3 V or 2.5 V. ZE and HE devices only accept 1.2 V as the external V_{CC} supply voltage. With the exception of power supply voltage all three types of devices (ZE, HC and HE) are functionally compatible and pin compatible with each other.

The MachXO2 PLDs are available in a broad range of advanced halogen-free packages ranging from the space saving 2.5 mm x 2.5 mm WLCSP to the 23 mm x 23 mm fpBGA. MachXO2 devices support density migration within the same package. Table 1-1 shows the LUT densities, package and I/O options, along with other key parameters.

The pre-engineered source synchronous logic implemented in the MachXO2 device family supports a broad range of interface standards, including LPDDR, DDR, DDR2 and 7:1 gearing for display I/Os.

The MachXO2 devices offer enhanced I/O features such as drive strength control, slew rate control, PCI compatibility, bus-keeper latches, pull-up resistors, pull-down resistors, open drain outputs and hot socketing. Pull-up, pull-down and bus-keeper features are controllable on a “per-pin” basis.

A user-programmable internal oscillator is included in MachXO2 devices. The clock output from this oscillator may be divided by the timer/counter for use as clock input in functions such as LED control, key-board scanner and similar state machines.

The MachXO2 devices also provide flexible, reliable and secure configuration from on-chip Flash memory. These devices can also configure themselves from external SPI Flash or be configured by an external master through the JTAG test access port or through the I²C port. Additionally, MachXO2 devices support dual-boot capability (using external Flash memory) and remote field upgrade (TransFR) capability.

Lattice provides a variety of design tools that allow complex designs to be efficiently implemented using the MachXO2 family of devices. Popular logic synthesis tools provide synthesis library support for MachXO2. Lattice design tools use the synthesis tool output along with the user-specified preferences and constraints to place and route the design in the MachXO2 device. These tools extract the timing from the routing and back-annotate it into the design for timing verification.

Lattice provides many pre-engineered IP (Intellectual Property) LatticeCORE™ modules, including a number of reference designs licensed free of charge, optimized for the MachXO2 PLD family. By using these configurable soft core IP cores as standardized blocks, users are free to concentrate on the unique aspects of their design, increasing their productivity.

The logic blocks, Programmable Functional Unit (PFU) and sysMEM EBR blocks, are arranged in a two-dimensional grid with rows and columns. Each row has either the logic blocks or the EBR blocks. The PIO cells are located at the periphery of the device, arranged in banks. The PFU contains the building blocks for logic, arithmetic, RAM, ROM, and register functions. The PIOs utilize a flexible I/O buffer referred to as a sysIO buffer that supports operation with a variety of interface standards. The blocks are connected with many vertical and horizontal routing channel resources. The place and route software tool automatically allocates these routing resources.

In the MachXO2 family, the number of sysIO banks varies by device. There are different types of I/O buffers on the different banks. Refer to the details in later sections of this document. The sysMEM EBRs are large, dedicated fast memory blocks; these blocks are found in MachXO2-640/U and larger devices. These blocks can be configured as RAM, ROM or FIFO. FIFO support includes dedicated FIFO pointer and flag “hard” control logic to minimize LUT usage.

The MachXO2 registers in PFU and sysI/O can be configured to be SET or RESET. After power up and device is configured, the device enters into user mode with these registers SET/RESET according to the configuration setting, allowing device entering to a known state for predictable system function.

The MachXO2 architecture also provides up to two sysCLOCK Phase Locked Loop (PLL) blocks on MachXO2-640U, MachXO2-1200/U and larger devices. These blocks are located at the ends of the on-chip Flash block. The PLLs have multiply, divide, and phase shifting capabilities that are used to manage the frequency and phase relationships of the clocks.

MachXO2 devices provide commonly used hardened functions such as SPI controller, I²C controller and timer/counter. MachXO2-640/U and higher density devices also provide User Flash Memory (UFM). These hardened functions and the UFM interface to the core logic and routing through a WISHBONE interface. The UFM can also be accessed through the SPI, I²C and JTAG ports.

Every device in the family has a JTAG port that supports programming and configuration of the device as well as access to the user logic. The MachXO2 devices are available for operation from 3.3 V, 2.5 V and 1.2 V power supplies, providing easy integration into the overall system.

PFU Blocks

The core of the MachXO2 device consists of PFU blocks, which can be programmed to perform logic, arithmetic, distributed RAM and distributed ROM functions. Each PFU block consists of four interconnected slices numbered 0 to 3 as shown in Figure 2-3. Each slice contains two LUTs and two registers. There are 53 inputs and 25 outputs associated with each PFU block.

Table 2-4. PLL Signal Descriptions (Continued)

Port Name	I/O	Description
CLKOP	O	Primary PLL output clock (with phase shift adjustment)
CLKOS	O	Secondary PLL output clock (with phase shift adjust)
CLKOS2	O	Secondary PLL output clock2 (with phase shift adjust)
CLKOS3	O	Secondary PLL output clock3 (with phase shift adjust)
LOCK	O	PLL LOCK, asynchronous signal. Active high indicates PLL is locked to input and feedback signals.
DPHSRC	O	Dynamic Phase source – ports or WISHBONE is active
STDBY	I	Standby signal to power down the PLL
RST	I	PLL reset without resetting the M-divider. Active high reset.
RESETM	I	PLL reset - includes resetting the M-divider. Active high reset.
RESETC	I	Reset for CLKOS2 output divider only. Active high reset.
RESETD	I	Reset for CLKOS3 output divider only. Active high reset.
ENCLKOP	I	Enable PLL output CLKOP
ENCLKOS	I	Enable PLL output CLKOS when port is active
ENCLKOS2	I	Enable PLL output CLKOS2 when port is active
ENCLKOS3	I	Enable PLL output CLKOS3 when port is active
PLLCLK	I	PLL data bus clock input signal
PLLRST	I	PLL data bus reset. This resets only the data bus not any register values.
PLLSTB	I	PLL data bus strobe signal
PLLWE	I	PLL data bus write enable signal
PLLADDR [4:0]	I	PLL data bus address
PLLDATI [7:0]	I	PLL data bus data input
PLLDATO [7:0]	O	PLL data bus data output
PLLACK	O	PLL data bus acknowledge signal

sysMEM Embedded Block RAM Memory

The MachXO2-640/U and larger devices contain sysMEM Embedded Block RAMs (EBRs). The EBR consists of a 9-kbit RAM, with dedicated input and output registers. This memory can be used for a wide variety of purposes including data buffering, PROM for the soft processor and FIFO.

sysMEM Memory Block

The sysMEM block can implement single port, dual port, pseudo dual port, or FIFO memories. Each block can be used in a variety of depths and widths as shown in Table 2-5.

Figure 2-12. MachXO2 Input Register Block Diagram (PIO on Left, Top and Bottom Edges)

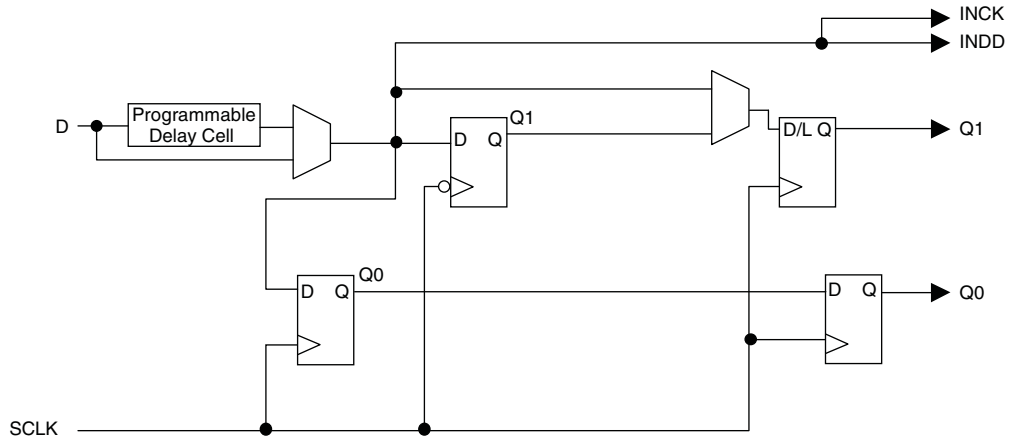

Right Edge

The input register block on the right edge is a superset of the same block on the top, bottom, and left edges. In addition to the modes described above, the input register block on the right edge also supports DDR memory mode.

In DDR memory mode, two registers are used to sample the data on the positive and negative edges of the modified DQS (DQSR90) in the DDR Memory mode creating two data streams. Before entering the core, these two data streams are synchronized to the system clock to generate two data streams.

The signal DDRCLKPOL controls the polarity of the clock used in the synchronization registers. It ensures adequate timing when data is transferred to the system clock domain from the DQS domain. The DQSR90 and DDRCLKPOL signals are generated in the DQS read-write block.

Figure 2-13. MachXO2 Input Register Block Diagram (PIO on Right Edge)

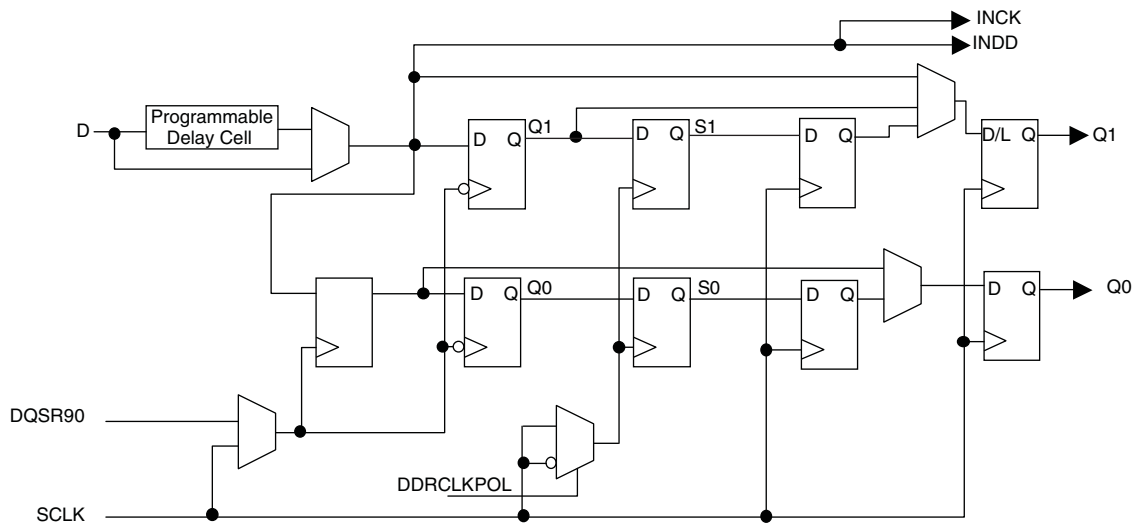

Output Register Block

The output register block registers signals from the core of the device before they are passed to the sysIO buffers.

Left, Top, Bottom Edges

In SDR mode, D0 feeds one of the flip-flops that then feeds the output. The flip-flop can be configured as a D-type register or latch.

In DDR generic mode, D0 and D1 inputs are fed into registers on the positive edge of the clock. At the next falling edge the registered D1 input is registered into the register Q1. A multiplexer running off the same clock is used to switch the mux between the outputs of registers Q0 and Q1 that will then feed the output.

Figure 2-14 shows the output register block on the left, top and bottom edges.

Figure 2-14. MachXO2 Output Register Block Diagram (PIO on the Left, Top and Bottom Edges)

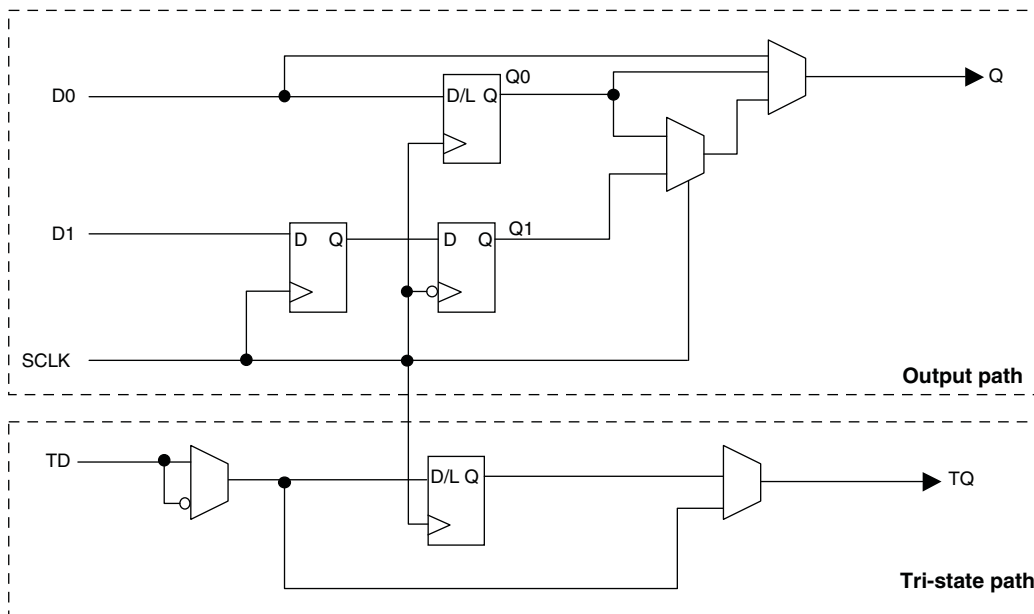

Right Edge

The output register block on the right edge is a superset of the output register on left, top and bottom edges of the device. In addition to supporting SDR and Generic DDR modes, the output register blocks for PIOs on the right edge include additional logic to support DDR-memory interfaces. Operation of this block is similar to that of the output register block on other edges.

In DDR memory mode, D0 and D1 inputs are fed into registers on the positive edge of the clock. At the next falling edge the registered D1 input is registered into the register Q1. A multiplexer running off the DQSW90 signal is used to switch the mux between the outputs of registers Q0 and Q1 that will then feed the output.

Figure 2-15 shows the output register block on the right edge.

These gearboxes have three stage pipeline registers. The first stage registers sample the high-speed input data by the high-speed edge clock on its rising and falling edges. The second stage registers perform data alignment based on the control signals UPDATE and SEL0 from the control block. The third stage pipeline registers pass the data to the device core synchronized to the low-speed system clock. Figure 2-16 shows a block diagram of the input gearbox.

Figure 2-16. Input Gearbox

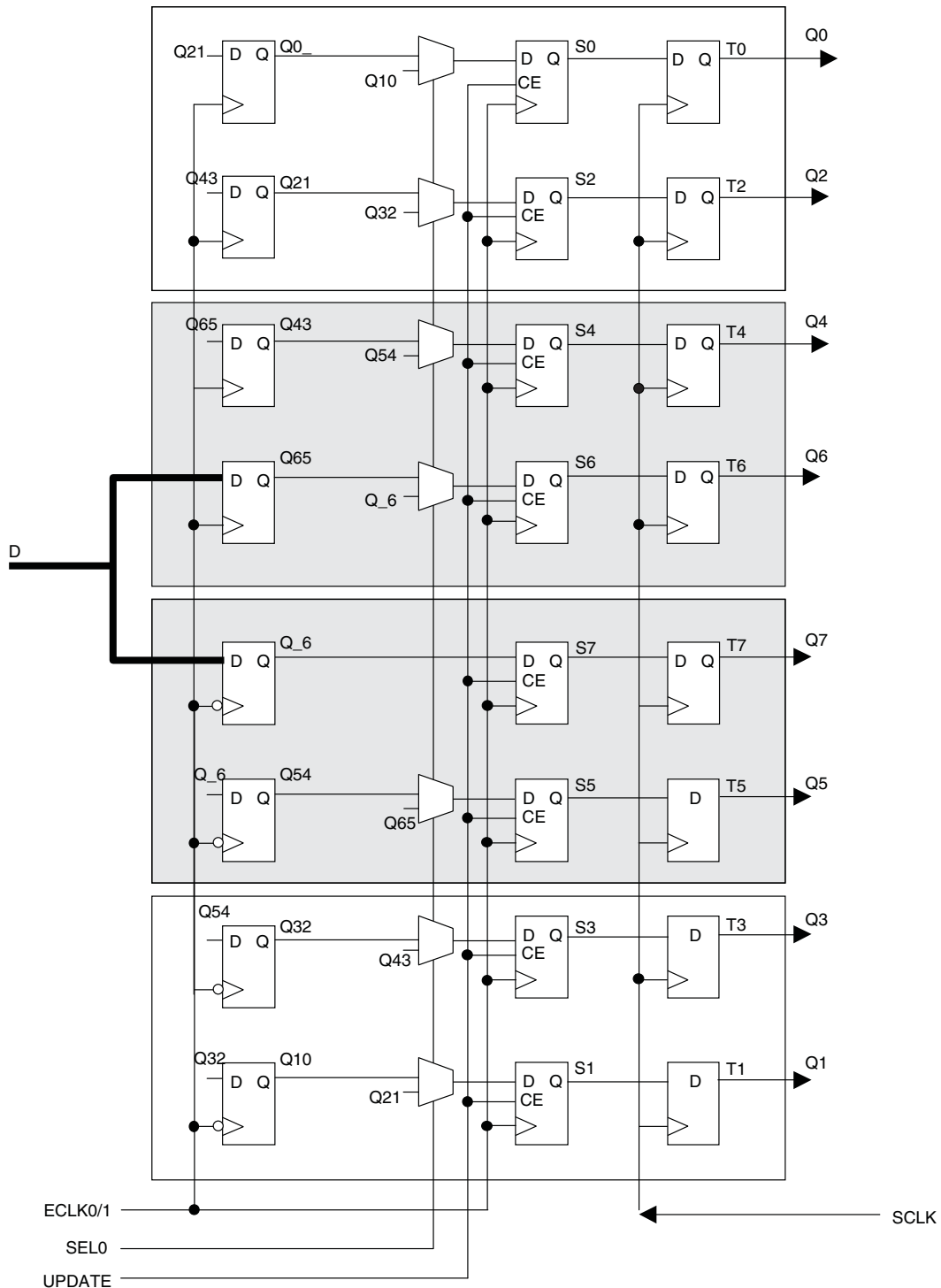
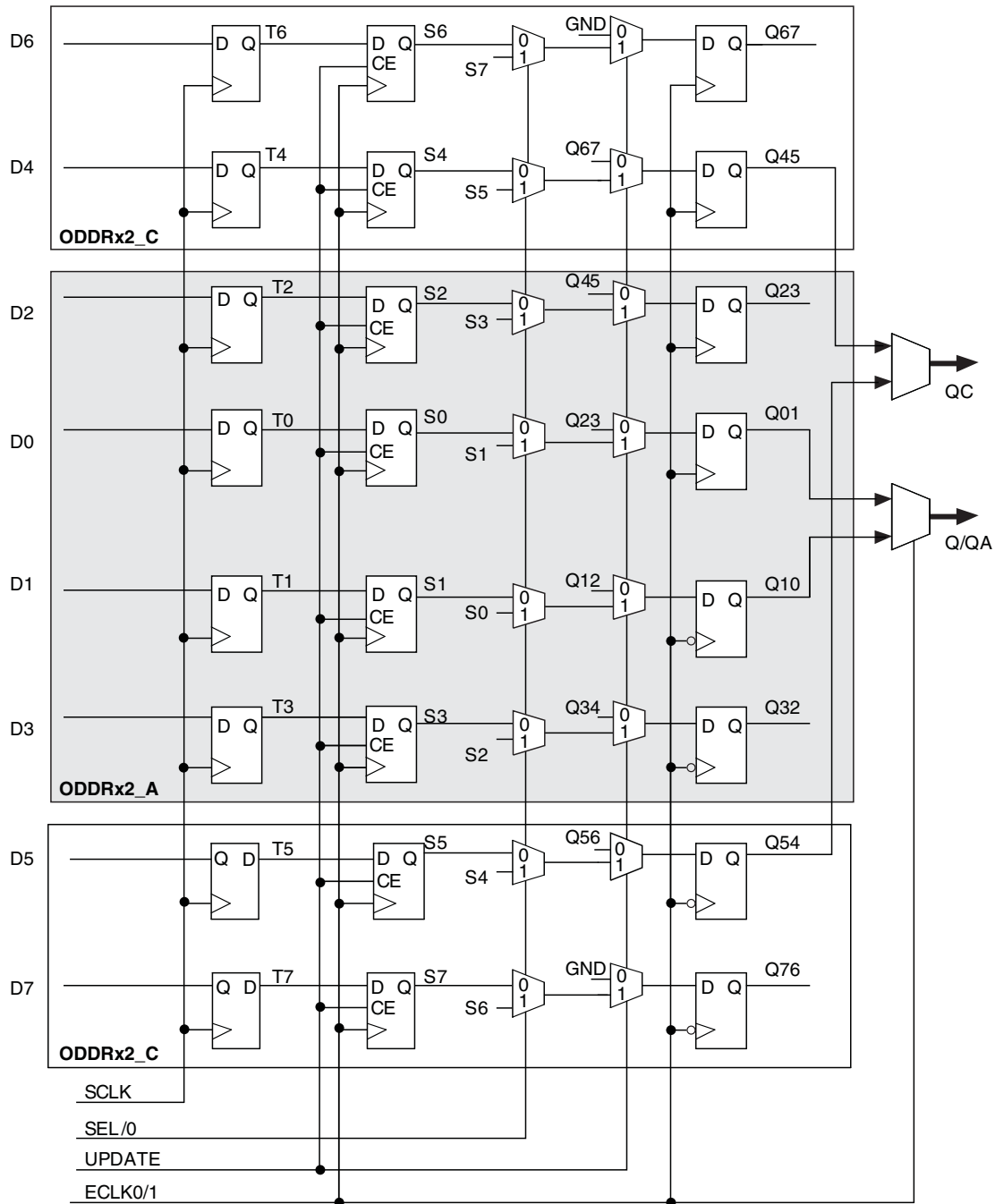

Figure 2-17. Output Gearbox



More information on the output gearbox is available in TN1203, [Implementing High-Speed Interfaces with MachXO2 Devices](#).

MachXO2-640U, MachXO2-1200/U, MachXO2-2000/U, MachXO2-4000 and MachXO2-7000 devices contain three types of sysIO buffer pairs.

1. Left and Right sysIO Buffer Pairs

The sysIO buffer pairs in the left and right banks of the device consist of two single-ended output drivers and two single-ended input buffers (for ratioed inputs such as LVCMOS and LVTTL). The I/O pairs on the left and right of the devices also have differential and referenced input buffers.

2. Bottom sysIO Buffer Pairs

The sysIO buffer pairs in the bottom bank of the device consist of two single-ended output drivers and two single-ended input buffers (for ratioed inputs such as LVCMOS and LVTTL). The I/O pairs on the bottom also have differential and referenced input buffers. Only the I/Os on the bottom banks have programmable PCI clamps and differential input termination. The PCI clamp is enabled after V_{CC} and V_{CCIO} are at valid operating levels and the device has been configured.

3. Top sysIO Buffer Pairs

The sysIO buffer pairs in the top bank of the device consist of two single-ended output drivers and two single-ended input buffers (for ratioed inputs such as LVCMOS and LVTTL). The I/O pairs on the top also have differential and referenced I/O buffers. Half of the sysIO buffer pairs on the top edge have true differential outputs. The sysIO buffer pair comprising of the A and B PIOs in every PIC on the top edge have a differential output driver. The referenced input buffer can also be configured as a differential input buffer.

Typical I/O Behavior During Power-up

The internal power-on-reset (POR) signal is deactivated when V_{CC} and V_{CCIO0} have reached V_{PORUP} level defined in the Power-On-Reset Voltage table in the DC and Switching Characteristics section of this data sheet. After the POR signal is deactivated, the FPGA core logic becomes active. It is the user's responsibility to ensure that all V_{CCIO} banks are active with valid input logic levels to properly control the output logic states of all the I/O banks that are critical to the application. The default configuration of the I/O pins in a blank device is tri-state with a weak pull-down to GND (some pins such as PROGRAMN and the JTAG pins have weak pull-up to V_{CCIO} as the default functionality). The I/O pins will maintain the blank configuration until V_{CC} and V_{CCIO} (for I/O banks containing configuration I/Os) have reached V_{PORUP} levels at which time the I/Os will take on the user-configured settings only after a proper download/configuration.

Supported Standards

The MachXO2 sysIO buffer supports both single-ended and differential standards. Single-ended standards can be further subdivided into LVCMOS, LVTTL, and PCI. The buffer supports the LVTTL, PCI, LVCMOS 1.2, 1.5, 1.8, 2.5, and 3.3 V standards. In the LVCMOS and LVTTL modes, the buffer has individually configurable options for drive strength, bus maintenance (weak pull-up, weak pull-down, bus-keeper latch or none) and open drain. BLVDS, MLVDS and LVPECL output emulation is supported on all devices. The MachXO2-640U, MachXO2-1200/U and higher devices support on-chip LVDS output buffers on approximately 50% of the I/Os on the top bank. Differential receivers for LVDS, BLVDS, MLVDS and LVPECL are supported on all banks of MachXO2 devices. PCI support is provided in the bottom bank of the MachXO2-640U, MachXO2-1200/U and higher density devices. Table 2-11 summarizes the I/O characteristics of the MachXO2 PLDs.

Tables 2-11 and 2-12 show the I/O standards (together with their supply and reference voltages) supported by the MachXO2 devices. For further information on utilizing the sysIO buffer to support a variety of standards please see TN1202, [MachXO2 sysIO Usage Guide](#).

Hardened Timer/Counter

MachXO2 devices provide a hard Timer/Counter IP core. This Timer/Counter is a general purpose, bi-directional, 16-bit timer/counter module with independent output compare units and PWM support. The Timer/Counter supports the following functions:

- Supports the following modes of operation:
 - Watchdog timer
 - Clear timer on compare match
 - Fast PWM
 - Phase and Frequency Correct PWM
- Programmable clock input source
- Programmable input clock prescaler
- One static interrupt output to routing
- One wake-up interrupt to on-chip standby mode controller.
- Three independent interrupt sources: overflow, output compare match, and input capture
- Auto reload
- Time-stamping support on the input capture unit
- Waveform generation on the output
- Glitch-free PWM waveform generation with variable PWM period
- Internal WISHBONE bus access to the control and status registers
- Stand-alone mode with preloaded control registers and direct reset input

Figure 2-23. Timer/Counter Block Diagram

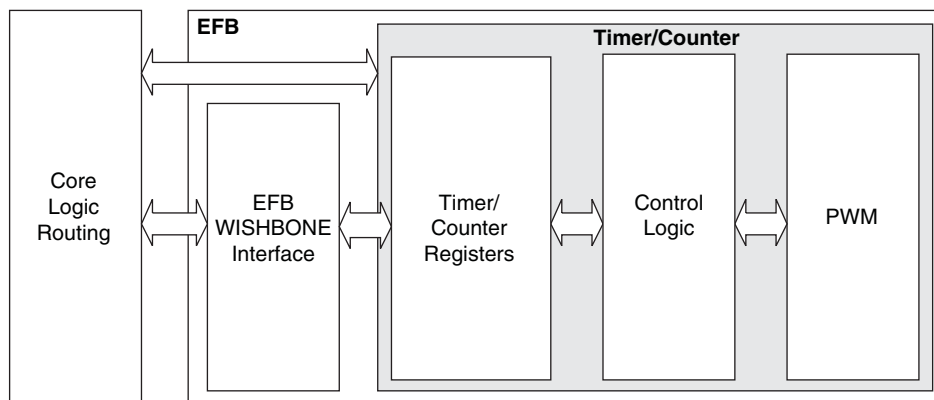

Table 2-17. Timer/Counter Signal Description

Port	I/O	Description
tc_clk	I	Timer/Counter input clock signal
tc_rstn	I	Register tc_rstn_ena is preloaded by configuration to always keep this pin enabled
tc_ic	I	Input capture trigger event, applicable for non-pwm modes with WISHBONE interface. If enabled, a rising edge of this signal will be detected and synchronized to capture tc_cnt value into tc_icr for time-stamping.
tc_int	O	Without WISHBONE – Can be used as overflow flag With WISHBONE – Controlled by three IRQ registers
tc_oc	O	Timer counter output signal

Configuration and Testing

This section describes the configuration and testing features of the MachXO2 family.

IEEE 1149.1-Compliant Boundary Scan Testability

All MachXO2 devices have boundary scan cells that are accessed through an IEEE 1149.1 compliant test access port (TAP). This allows functional testing of the circuit board, on which the device is mounted, through a serial scan path that can access all critical logic nodes. Internal registers are linked internally, allowing test data to be shifted in and loaded directly onto test nodes, or test data to be captured and shifted out for verification. The test access port consists of dedicated I/Os: TDI, TDO, TCK and TMS. The test access port shares its power supply with V_{CCIO} Bank 0 and can operate with LVCMOS3.3, 2.5, 1.8, 1.5, and 1.2 standards.

For more details on boundary scan test, see AN8066, [Boundary Scan Testability with Lattice sysIO Capability](#) and TN1087, [Minimizing System Interruption During Configuration Using TransFR Technology](#).

Device Configuration

All MachXO2 devices contain two ports that can be used for device configuration. The Test Access Port (TAP), which supports bit-wide configuration and the sysCONFIG port which supports serial configuration through I²C or SPI. The TAP supports both the IEEE Standard 1149.1 Boundary Scan specification and the IEEE Standard 1532 In-System Configuration specification. There are various ways to configure a MachXO2 device:

1. Internal Flash Download
2. JTAG
3. Standard Serial Peripheral Interface (Master SPI mode) – interface to boot PROM memory
4. System microprocessor to drive a serial slave SPI port (SSPI mode)
5. Standard I²C Interface to system microprocessor

Upon power-up, the configuration SRAM is ready to be configured using the selected sysCONFIG port. Once a configuration port is selected, it will remain active throughout that configuration cycle. The IEEE 1149.1 port can be activated any time after power-up by sending the appropriate command through the TAP port. Optionally the device can run a CRC check upon entering the user mode. This will ensure that the device was configured correctly.

The sysCONFIG port has 10 dual-function pins which can be used as general purpose I/Os if they are not required for configuration. See TN1204, [MachXO2 Programming and Configuration Usage Guide](#) for more information about using the dual-use pins as general purpose I/Os.

Lattice design software uses proprietary compression technology to compress bit-streams for use in MachXO2 devices. Use of this technology allows Lattice to provide a lower cost solution. In the unlikely event that this technology is unable to compress bitstreams to fit into the amount of on-chip Flash memory, there are a variety of techniques that can be utilized to allow the bitstream to fit in the on-chip Flash memory. For more details, refer to TN1204, [MachXO2 Programming and Configuration Usage Guide](#).

The Test Access Port (TAP) has five dual purpose pins (TDI, TDO, TMS, TCK and JTAGENB). These pins are dual function pins - TDI, TDO, TMS and TCK can be used as general purpose I/O if desired. For more details, refer to TN1204, [MachXO2 Programming and Configuration Usage Guide](#).

TransFR (Transparent Field Reconfiguration)

TransFR is a unique Lattice technology that allows users to update their logic in the field without interrupting system operation using a simple push-button solution. For more details refer to TN1087, [Minimizing System Interruption During Configuration Using TransFR Technology](#) for details.

Static Supply Current – ZE Devices^{1, 2, 3, 6}

Symbol	Parameter	Device	Typ. ⁴	Units
I _{CC}	Core Power Supply	LCMXO2-256ZE	18	μA
		LCMXO2-640ZE	28	μA
		LCMXO2-1200ZE	56	μA
		LCMXO2-2000ZE	80	μA
		LCMXO2-4000ZE	124	μA
		LCMXO2-7000ZE	189	μA
I _{CCIO}	Bank Power Supply ⁵ V _{CCIO} = 2.5 V	All devices	1	μA

- For further information on supply current, please refer to TN1198, [Power Estimation and Management for MachXO2 Devices](#).
- Assumes blank pattern with the following characteristics: all outputs are tri-stated, all inputs are configured as LVCMOS and held at V_{CCIO} or GND, on-chip oscillator is off, on-chip PLL is off. To estimate the impact of turning each of these items on, please refer to the following table or for more detail with your specific design use the Power Calculator tool.
- Frequency = 0 MHz.
- T_J = 25 °C, power supplies at nominal voltage.
- Does not include pull-up/pull-down.
- To determine the MachXO2 peak start-up current data, use the Power Calculator tool.

Static Power Consumption Contribution of Different Components – ZE Devices

The table below can be used for approximating static power consumption. For a more accurate power analysis for your design please use the Power Calculator tool.

Symbol	Parameter	Typ.	Units
I _{DCBG}	Bandgap DC power contribution	101	μA
I _{DCPOR}	POR DC power contribution	38	μA
I _{DCIOBANKCONTROLLER}	DC power contribution per I/O bank controller	143	μA

LVDS Emulation

MachXO2 devices can support LVDS outputs via emulation (LVDS25E). The output is emulated using complementary LVCMOS outputs in conjunction with resistors across the driver outputs on all devices. The scheme shown in Figure 3-1 is one possible solution for LVDS standard implementation. Resistor values in Figure 3-1 are industry standard values for 1% resistors.

Figure 3-1. LVDS Using External Resistors (LVDS25E)

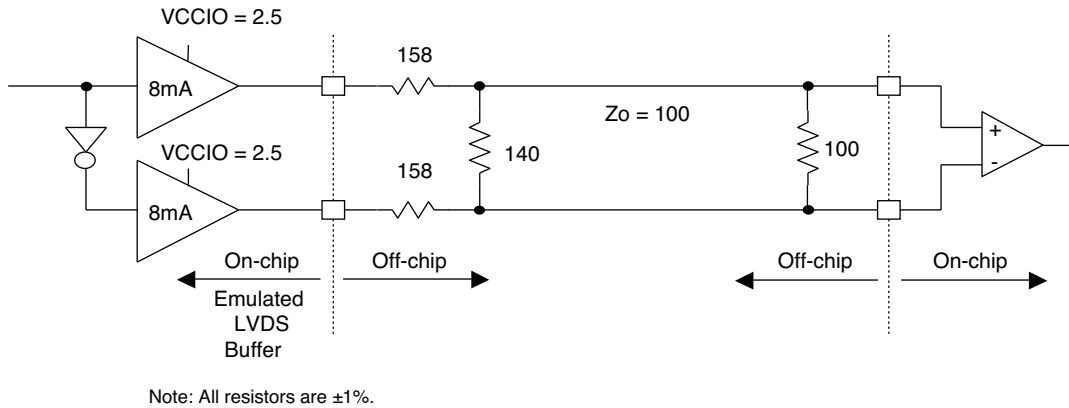

Table 3-1. LVDS25E DC Conditions

Over Recommended Operating Conditions

Parameter	Description	Typ.	Units
Z_{OUT}	Output impedance	20	Ohms
R_S	Driver series resistor	158	Ohms
R_P	Driver parallel resistor	140	Ohms
R_T	Receiver termination	100	Ohms
V_{OH}	Output high voltage	1.43	V
V_{OL}	Output low voltage	1.07	V
V_{OD}	Output differential voltage	0.35	V
V_{CM}	Output common mode voltage	1.25	V
Z_{BACK}	Back impedance	100.5	Ohms
I_{DC}	DC output current	6.03	mA

BLVDS

The MachXO2 family supports the BLVDS standard through emulation. The output is emulated using complementary LVCMOS outputs in conjunction with resistors across the driver outputs. The input standard is supported by the LVDS differential input buffer. BLVDS is intended for use when multi-drop and bi-directional multi-point differential signaling is required. The scheme shown in Figure 3-2 is one possible solution for bi-directional multi-point differential signals.

Figure 3-2. BLVDS Multi-point Output Example

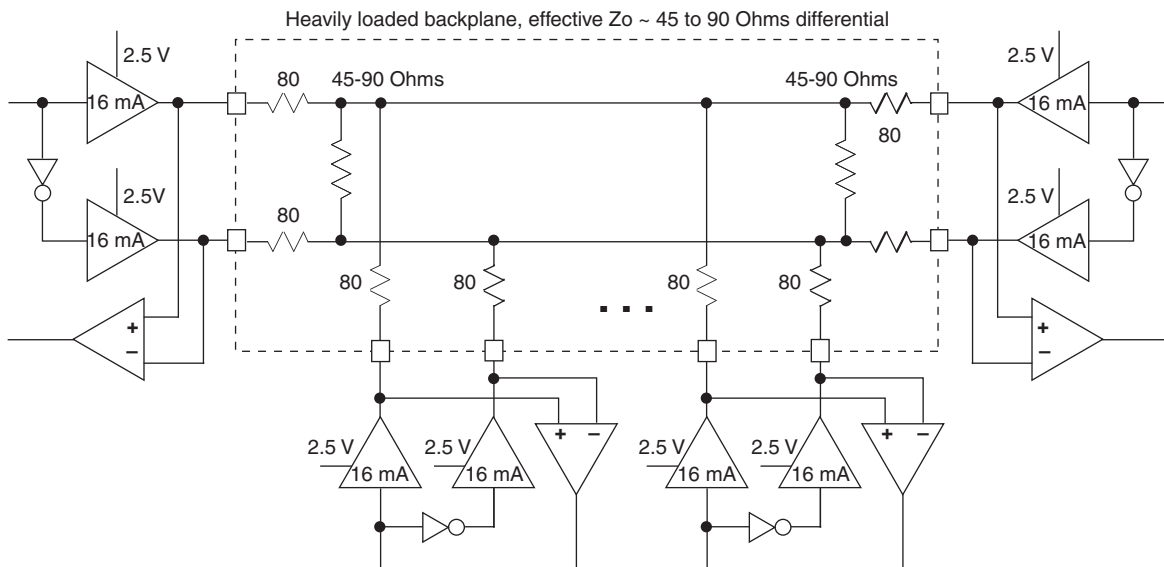

Table 3-2. BLVDS DC Conditions¹

Over Recommended Operating Conditions

Symbol	Description	Nominal		Units
		Zo = 45	Zo = 90	
Z _{OUT}	Output impedance	20	20	Ohms
R _S	Driver series resistance	80	80	Ohms
R _{TLEFT}	Left end termination	45	90	Ohms
R _{TRIGHT}	Right end termination	45	90	Ohms
V _{OH}	Output high voltage	1.376	1.480	V
V _{OL}	Output low voltage	1.124	1.020	V
V _{OD}	Output differential voltage	0.253	0.459	V
V _{CM}	Output common mode voltage	1.250	1.250	V
I _{DC}	DC output current	11.236	10.204	mA

1. For input buffer, see LVDS table.

Parameter	Description	Device	-6		-5		-4		Units
			Min.	Max.	Min.	Max.	Min.	Max.	
t _{SU_DEL}	Clock to Data Setup – PIO Input Register with Data Input Delay	MachXO2-256HC-HE	1.42	—	1.59	—	1.96	—	ns
		MachXO2-640HC-HE	1.41	—	1.58	—	1.96	—	ns
		MachXO2-1200HC-HE	1.63	—	1.79	—	2.17	—	ns
		MachXO2-2000HC-HE	1.61	—	1.76	—	2.13	—	ns
		MachXO2-4000HC-HE	1.66	—	1.81	—	2.19	—	ns
		MachXO2-7000HC-HE	1.53	—	1.67	—	2.03	—	ns
t _{H_DEL}	Clock to Data Hold – PIO Input Register with Input Data Delay	MachXO2-256HC-HE	-0.24	—	-0.24	—	-0.24	—	ns
		MachXO2-640HC-HE	-0.23	—	-0.23	—	-0.23	—	ns
		MachXO2-1200HC-HE	-0.24	—	-0.24	—	-0.24	—	ns
		MachXO2-2000HC-HE	-0.23	—	-0.23	—	-0.23	—	ns
		MachXO2-4000HC-HE	-0.25	—	-0.25	—	-0.25	—	ns
		MachXO2-7000HC-HE	-0.21	—	-0.21	—	-0.21	—	ns
f _{MAX_IO}	Clock Frequency of I/O and PFU Register	All MachXO2 devices	—	388	—	323	—	269	MHz
General I/O Pin Parameters (Using Edge Clock without PLL)									
t _{COE}	Clock to Output – PIO Output Register	MachXO2-1200HC-HE	—	7.53	—	7.76	—	8.10	ns
		MachXO2-2000HC-HE	—	7.53	—	7.76	—	8.10	ns
		MachXO2-4000HC-HE	—	7.45	—	7.68	—	8.00	ns
		MachXO2-7000HC-HE	—	7.53	—	7.76	—	8.10	ns
t _{SUE}	Clock to Data Setup – PIO Input Register	MachXO2-1200HC-HE	-0.19	—	-0.19	—	-0.19	—	ns
		MachXO2-2000HC-HE	-0.19	—	-0.19	—	-0.19	—	ns
		MachXO2-4000HC-HE	-0.16	—	-0.16	—	-0.16	—	ns
		MachXO2-7000HC-HE	-0.19	—	-0.19	—	-0.19	—	ns
t _{HE}	Clock to Data Hold – PIO Input Register	MachXO2-1200HC-HE	1.97	—	2.24	—	2.52	—	ns
		MachXO2-2000HC-HE	1.97	—	2.24	—	2.52	—	ns
		MachXO2-4000HC-HE	1.89	—	2.16	—	2.43	—	ns
		MachXO2-7000HC-HE	1.97	—	2.24	—	2.52	—	ns
t _{SU_DELE}	Clock to Data Setup – PIO Input Register with Data Input Delay	MachXO2-1200HC-HE	1.56	—	1.69	—	2.05	—	ns
		MachXO2-2000HC-HE	1.56	—	1.69	—	2.05	—	ns
		MachXO2-4000HC-HE	1.74	—	1.88	—	2.25	—	ns
		MachXO2-7000HC-HE	1.66	—	1.81	—	2.17	—	ns
t _{H_DELE}	Clock to Data Hold – PIO Input Register with Input Data Delay	MachXO2-1200HC-HE	-0.23	—	-0.23	—	-0.23	—	ns
		MachXO2-2000HC-HE	-0.23	—	-0.23	—	-0.23	—	ns
		MachXO2-4000HC-HE	-0.34	—	-0.34	—	-0.34	—	ns
		MachXO2-7000HC-HE	-0.29	—	-0.29	—	-0.29	—	ns
General I/O Pin Parameters (Using Primary Clock with PLL)									
t _{COPLL}	Clock to Output – PIO Output Register	MachXO2-1200HC-HE	—	5.97	—	6.00	—	6.13	ns
		MachXO2-2000HC-HE	—	5.98	—	6.01	—	6.14	ns
		MachXO2-4000HC-HE	—	5.99	—	6.02	—	6.16	ns
		MachXO2-7000HC-HE	—	6.02	—	6.06	—	6.20	ns
t _{SUPLL}	Clock to Data Setup – PIO Input Register	MachXO2-1200HC-HE	0.36	—	0.36	—	0.65	—	ns
		MachXO2-2000HC-HE	0.36	—	0.36	—	0.63	—	ns
		MachXO2-4000HC-HE	0.35	—	0.35	—	0.62	—	ns
		MachXO2-7000HC-HE	0.34	—	0.34	—	0.59	—	ns

Parameter	Description	Device	-3		-2		-1		Units
			Min.	Max.	Min.	Max.	Min.	Max.	
Generic DDR4 Inputs with Clock and Data Centered at Pin Using PCLK Pin for Clock Input – GDDR4_RX.ECLK.Centered^{9, 12}									
t _{SU}	Input Data Setup Before ECLK	MachXO2-640U, MachXO2-1200/U and larger devices, bottom side only ¹¹	0.434	—	0.535	—	0.630	—	ns
t _{HO}	Input Data Hold After ECLK		0.385	—	0.395	—	0.463	—	ns
f _{DATA}	DDR4 Serial Input Data Speed		—	420	—	352	—	292	Mbps
f _{DDR4}	DDR4 ECLK Frequency		—	210	—	176	—	146	MHz
f _{SCLK}	SCLK Frequency		—	53	—	44	—	37	MHz
7:1 LVDS Inputs – GDDR71_RX.ECLK.7.1^{9, 12}									
t _{DVA}	Input Data Valid After ECLK	MachXO2-640U, MachXO2-1200/U and larger devices, bottom side only ¹¹	—	0.307	—	0.316	—	0.326	UI
t _{DVE}	Input Data Hold After ECLK		0.662	—	0.650	—	0.649	—	UI
f _{DATA}	DDR71 Serial Input Data Speed		—	420	—	352	—	292	Mbps
f _{DDR71}	DDR71 ECLK Frequency		—	210	—	176	—	146	MHz
f _{CLKIN}	7:1 Input Clock Frequency (SCLK) (minimum limited by PLL)		—	60	—	50	—	42	MHz
Generic DDR Outputs with Clock and Data Aligned at Pin Using PCLK Pin for Clock Input – GDDR1_TX.SCLK.Aligned^{9, 12}									
t _{DIA}	Output Data Invalid After CLK Output	All MachXO2 devices, all sides	—	0.850	—	0.910	—	0.970	ns
t _{DIB}	Output Data Invalid Before CLK Output		—	0.850	—	0.910	—	0.970	ns
f _{DATA}	DDR1 Output Data Speed		—	140	—	116	—	98	Mbps
f _{DDR1}	DDR1 SCLK frequency		—	70	—	58	—	49	MHz
Generic DDR Outputs with Clock and Data Centered at Pin Using PCLK Pin for Clock Input – GDDR1_TX.SCLK.Centered^{9, 12}									
t _{DVB}	Output Data Valid Before CLK Output	All MachXO2 devices, all sides	2.720	—	3.380	—	4.140	—	ns
t _{DVA}	Output Data Valid After CLK Output		2.720	—	3.380	—	4.140	—	ns
f _{DATA}	DDR1 Output Data Speed		—	140	—	116	—	98	Mbps
f _{DDR1}	DDR1 SCLK Frequency (minimum limited by PLL)		—	70	—	58	—	49	MHz
Generic DDRX2 Outputs with Clock and Data Aligned at Pin Using PCLK Pin for Clock Input – GDDR2_TX.ECLK.Aligned^{9, 12}									
t _{DIA}	Output Data Invalid After CLK Output	MachXO2-640U, MachXO2-1200/U and larger devices, top side only	—	0.270	—	0.300	—	0.330	ns
t _{DIB}	Output Data Invalid Before CLK Output		—	0.270	—	0.300	—	0.330	ns
f _{DATA}	DDR2 Serial Output Data Speed		—	280	—	234	—	194	Mbps
f _{DDR2}	DDR2 ECLK frequency		—	140	—	117	—	97	MHz
f _{SCLK}	SCLK Frequency		—	70	—	59	—	49	MHz

MachXO2 Oscillator Output Frequency

Symbol	Parameter	Min.	Typ.	Max	Units
f _{MAX}	Oscillator Output Frequency (Commercial Grade Devices, 0 to 85°C)	125.685	133	140.315	MHz
	Oscillator Output Frequency (Industrial Grade Devices, -40 °C to 100 °C)	124.355	133	141.645	MHz
t _{DT}	Output Clock Duty Cycle	43	50	57	%
t _{OPJIT} ¹	Output Clock Period Jitter	0.01	0.012	0.02	UIPP
t _{STABLEOSC}	STDBY Low to Oscillator Stable	0.01	0.05	0.1	µs

1. Output Clock Period Jitter specified at 133 MHz. The values for lower frequencies will be smaller UIPP. The typical value for 133 MHz is 95 ps and for 2.08 MHz the typical value is 1.54 ns.

MachXO2 Standby Mode Timing – HC/HE Devices

Symbol	Parameter	Device	Min.	Typ.	Max	Units
t _{PWRDN}	USERSTDBY High to Stop	All	—	—	9	ns
t _{PWRUP}	USERSTDBY Low to Power Up	LCMXO2-256		—		µs
		LCMXO2-640		—		µs
		LCMXO2-640U		—		µs
		LCMXO2-1200	20	—	50	µs
		LCMXO2-1200U		—		µs
		LCMXO2-2000		—		µs
		LCMXO2-2000U		—		µs
		LCMXO2-4000		—		µs
LCMXO2-7000		—		µs		
t _{WSTDBY}	USERSTDBY Pulse Width	All	18	—	—	ns

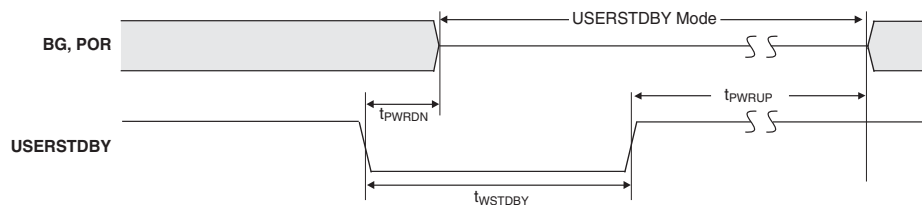

MachXO2 Standby Mode Timing – ZE Devices

Symbol	Parameter	Device	Min.	Typ.	Max	Units
t _{PWRDN}	USERSTDBY High to Stop	All	—	—	13	ns
t _{PWRUP}	USERSTDBY Low to Power Up	LCMXO2-256		—		µs
		LCMXO2-640		—		µs
		LCMXO2-1200	20	—	50	µs
		LCMXO2-2000		—		µs
		LCMXO2-4000		—		µs
LCMXO2-7000		—		µs		
t _{WSTDBY}	USERSTDBY Pulse Width	All	19	—	—	ns
t _{BNDGAPSTBL}	USERSTDBY High to Bandgap Stable	All	—	—	15	ns

Signal Descriptions (Cont.)

Signal Name	I/O	Descriptions
INITN	I/O	Open Drain pin. Indicates the FPGA is ready to be configured. During configuration, or when reserved as INITn in user mode, this pin has an active pull-up.
DONE	I/O	Open Drain pin. Indicates that the configuration sequence is complete, and the start-up sequence is in progress. During configuration, or when reserved as DONE in user mode, this pin has an active pull-up.
MCLK/CCLK	I/O	Input Configuration Clock for configuring an FPGA in Slave SPI mode. Output Configuration Clock for configuring an FPGA in SPI and SPIm configuration modes.
SN	I	Slave SPI active low chip select input.
CSSPIN	I/O	Master SPI active low chip select output.
SI/SPISI	I/O	Slave SPI serial data input and master SPI serial data output.
SO/SPISO	I/O	Slave SPI serial data output and master SPI serial data input.
SCL	I/O	Slave I ² C clock input and master I ² C clock output.
SDA	I/O	Slave I ² C data input and master I ² C data output.

	MachXO2-2000						MachXO2-2000U
	49 WLCSP	100 TQFP	132 csBGA	144 TQFP	256 caBGA	256 ftBGA	484 ftBGA
General Purpose I/O per Bank							
Bank 0	19	18	25	27	50	50	70
Bank 1	0	21	26	28	52	52	68
Bank 2	13	20	28	28	52	52	72
Bank 3	0	6	7	8	16	16	24
Bank 4	0	6	8	10	16	16	16
Bank 5	6	8	10	10	20	20	28
Total General Purpose Single-Ended I/O	38	79	104	111	206	206	278
Differential I/O per Bank							
Bank 0	7	9	13	14	25	25	35
Bank 1	0	10	13	14	26	26	34
Bank 2	6	10	14	14	26	26	36
Bank 3	0	3	3	4	8	8	12
Bank 4	0	3	4	5	8	8	8
Bank 5	3	4	5	5	10	10	14
Total General Purpose Differential I/O	16	39	52	56	103	103	139
Dual Function I/O							
	24	31	33	33	33	33	37
High-speed Differential I/O							
Bank 0	5	4	8	9	14	14	18
Gearboxes							
Number of 7:1 or 8:1 Output Gearbox Available (Bank 0)	5	4	8	9	14	14	18
Number of 7:1 or 8:1 Input Gearbox Available (Bank 2)	6	10	14	14	14	14	18
DQS Groups							
Bank 1	0	1	2	2	2	2	2
VCCIO Pins							
Bank 0	2	2	3	3	4	4	10
Bank 1	0	2	3	3	4	4	10
Bank 2	1	2	3	3	4	4	10
Bank 3	0	1	1	1	1	1	3
Bank 4	0	1	1	1	2	2	4
Bank 5	1	1	1	1	1	1	3
VCC	2	2	4	4	8	8	12
GND	4	8	10	12	24	24	48
NC	0	1	1	4	1	1	105
Reserved for Configuration	1	1	1	1	v	1	1
Total Count of Bonded Pins	39	100	132	144	256	256	484

High-Performance Commercial Grade Devices with Voltage Regulator, Halogen Free (RoHS) Packaging

Part Number	LUTs	Supply Voltage	Grade	Package	Leads	Temp.
LCMXO2-256HC-4SG32C	256	2.5 V / 3.3 V	-4	Halogen-Free QFN	32	COM
LCMXO2-256HC-5SG32C	256	2.5 V / 3.3 V	-5	Halogen-Free QFN	32	COM
LCMXO2-256HC-6SG32C	256	2.5 V / 3.3 V	-6	Halogen-Free QFN	32	COM
LCMXO2-256HC-4SG48C	256	2.5 V / 3.3 V	-4	Halogen-Free QFN	48	COM
LCMXO2-256HC-5SG48C	256	2.5 V / 3.3 V	-5	Halogen-Free QFN	48	COM
LCMXO2-256HC-6SG48C	256	2.5 V / 3.3 V	-6	Halogen-Free QFN	48	COM
LCMXO2-256HC-4UMG64C	256	2.5 V / 3.3 V	-4	Halogen-Free ucBGA	64	COM
LCMXO2-256HC-5UMG64C	256	2.5 V / 3.3 V	-5	Halogen-Free ucBGA	64	COM
LCMXO2-256HC-6UMG64C	256	2.5 V / 3.3 V	-6	Halogen-Free ucBGA	64	COM
LCMXO2-256HC-4TG100C	256	2.5 V / 3.3 V	-4	Halogen-Free TQFP	100	COM
LCMXO2-256HC-5TG100C	256	2.5 V / 3.3 V	-5	Halogen-Free TQFP	100	COM
LCMXO2-256HC-6TG100C	256	2.5 V / 3.3 V	-6	Halogen-Free TQFP	100	COM
LCMXO2-256HC-4MG132C	256	2.5 V / 3.3 V	-4	Halogen-Free csBGA	132	COM
LCMXO2-256HC-5MG132C	256	2.5 V / 3.3 V	-5	Halogen-Free csBGA	132	COM
LCMXO2-256HC-6MG132C	256	2.5 V / 3.3 V	-6	Halogen-Free csBGA	132	COM

Part Number	LUTs	Supply Voltage	Grade	Package	Leads	Temp.
LCMXO2-640HC-4SG48C	640	2.5 V / 3.3 V	-4	Halogen-Free QFN	48	COM
LCMXO2-640HC-5SG48C	640	2.5 V / 3.3 V	-5	Halogen-Free QFN	48	COM
LCMXO2-640HC-6SG48C	640	2.5 V / 3.3 V	-6	Halogen-Free QFN	48	COM
LCMXO2-640HC-4TG100C	640	2.5 V / 3.3 V	-4	Halogen-Free TQFP	100	COM
LCMXO2-640HC-5TG100C	640	2.5 V / 3.3 V	-5	Halogen-Free TQFP	100	COM
LCMXO2-640HC-6TG100C	640	2.5 V / 3.3 V	-6	Halogen-Free TQFP	100	COM
LCMXO2-640HC-4MG132C	640	2.5 V / 3.3 V	-4	Halogen-Free csBGA	132	COM
LCMXO2-640HC-5MG132C	640	2.5 V / 3.3 V	-5	Halogen-Free csBGA	132	COM
LCMXO2-640HC-6MG132C	640	2.5 V / 3.3 V	-6	Halogen-Free csBGA	132	COM

Part Number	LUTs	Supply Voltage	Grade	Package	Leads	Temp.
LCMXO2-640UHC-4TG144C	640	2.5 V / 3.3 V	-4	Halogen-Free TQFP	144	COM
LCMXO2-640UHC-5TG144C	640	2.5 V / 3.3 V	-5	Halogen-Free TQFP	144	COM
LCMXO2-640UHC-6TG144C	640	2.5 V / 3.3 V	-6	Halogen-Free TQFP	144	COM

Part Number	LUTs	Supply Voltage	Grade	Package	Leads	Temp.
LCMXO2-4000ZE-1QN84I	4320	1.2 V	-1	Halogen-Free QFN	84	IND
LCMXO2-4000ZE-2QN84I	4320	1.2 V	-2	Halogen-Free QFN	84	IND
LCMXO2-4000ZE-3QN84I	4320	1.2 V	-3	Halogen-Free QFN	84	IND
LCMXO2-4000ZE-1MG132I	4320	1.2 V	-1	Halogen-Free csBGA	132	IND
LCMXO2-4000ZE-2MG132I	4320	1.2 V	-2	Halogen-Free csBGA	132	IND
LCMXO2-4000ZE-3MG132I	4320	1.2 V	-3	Halogen-Free csBGA	132	IND
LCMXO2-4000ZE-1TG144I	4320	1.2 V	-1	Halogen-Free TQFP	144	IND
LCMXO2-4000ZE-2TG144I	4320	1.2 V	-2	Halogen-Free TQFP	144	IND
LCMXO2-4000ZE-3TG144I	4320	1.2 V	-3	Halogen-Free TQFP	144	IND
LCMXO2-4000ZE-1BG256I	4320	1.2 V	-1	Halogen-Free caBGA	256	IND
LCMXO2-4000ZE-2BG256I	4320	1.2 V	-2	Halogen-Free caBGA	256	IND
LCMXO2-4000ZE-3BG256I	4320	1.2 V	-3	Halogen-Free caBGA	256	IND
LCMXO2-4000ZE-1FTG256I	4320	1.2 V	-1	Halogen-Free ftBGA	256	IND
LCMXO2-4000ZE-2FTG256I	4320	1.2 V	-2	Halogen-Free ftBGA	256	IND
LCMXO2-4000ZE-3FTG256I	4320	1.2 V	-3	Halogen-Free ftBGA	256	IND
LCMXO2-4000ZE-1BG332I	4320	1.2 V	-1	Halogen-Free caBGA	332	IND
LCMXO2-4000ZE-2BG332I	4320	1.2 V	-2	Halogen-Free caBGA	332	IND
LCMXO2-4000ZE-3BG332I	4320	1.2 V	-3	Halogen-Free caBGA	332	IND
LCMXO2-4000ZE-1FG484I	4320	1.2 V	-1	Halogen-Free fpBGA	484	IND
LCMXO2-4000ZE-2FG484I	4320	1.2 V	-2	Halogen-Free fpBGA	484	IND
LCMXO2-4000ZE-3FG484I	4320	1.2 V	-3	Halogen-Free fpBGA	484	IND

Part Number	LUTs	Supply Voltage	Grade	Package	Leads	Temp.
LCMXO2-7000ZE-1TG144I	6864	1.2 V	-1	Halogen-Free TQFP	144	IND
LCMXO2-7000ZE-2TG144I	6864	1.2 V	-2	Halogen-Free TQFP	144	IND
LCMXO2-7000ZE-3TG144I	6864	1.2 V	-3	Halogen-Free TQFP	144	IND
LCMXO2-7000ZE-1BG256I	6864	1.2 V	-1	Halogen-Free caBGA	256	IND
LCMXO2-7000ZE-2BG256I	6864	1.2 V	-2	Halogen-Free caBGA	256	IND
LCMXO2-7000ZE-3BG256I	6864	1.2 V	-3	Halogen-Free caBGA	256	IND
LCMXO2-7000ZE-1FTG256I	6864	1.2 V	-1	Halogen-Free ftBGA	256	IND
LCMXO2-7000ZE-2FTG256I	6864	1.2 V	-2	Halogen-Free ftBGA	256	IND
LCMXO2-7000ZE-3FTG256I	6864	1.2 V	-3	Halogen-Free ftBGA	256	IND
LCMXO2-7000ZE-1BG332I	6864	1.2 V	-1	Halogen-Free caBGA	332	IND
LCMXO2-7000ZE-2BG332I	6864	1.2 V	-2	Halogen-Free caBGA	332	IND
LCMXO2-7000ZE-3BG332I	6864	1.2 V	-3	Halogen-Free caBGA	332	IND
LCMXO2-7000ZE-1FG484I	6864	1.2 V	-1	Halogen-Free fpBGA	484	IND
LCMXO2-7000ZE-2FG484I	6864	1.2 V	-2	Halogen-Free fpBGA	484	IND
LCMXO2-7000ZE-3FG484I	6864	1.2 V	-3	Halogen-Free fpBGA	484	IND