

Welcome to [E-XFL.COM](https://www.e-xfl.com)

Understanding Embedded - FPGAs (Field Programmable Gate Array)

Embedded - FPGAs, or Field Programmable Gate Arrays, are advanced integrated circuits that offer unparalleled flexibility and performance for digital systems. Unlike traditional fixed-function logic devices, FPGAs can be programmed and reprogrammed to execute a wide array of logical operations, enabling customized functionality tailored to specific applications. This reprogrammability allows developers to iterate designs quickly and implement complex functions without the need for custom hardware.

Applications of Embedded - FPGAs

The versatility of Embedded - FPGAs makes them indispensable in numerous fields. In telecommunications,

Details

Product Status	Active
Number of LABs/CLBs	-
Number of Logic Elements/Cells	-
Total RAM Bits	-
Number of I/O	34
Number of Gates	3000
Voltage - Supply	3V ~ 3.6V, 4.5V ~ 5.5V
Mounting Type	Surface Mount
Operating Temperature	-55°C ~ 125°C (TC)
Package / Case	44-LCC (J-Lead)
Supplier Device Package	44-PLCC (16.59x16.59)
Purchase URL	https://www.e-xfl.com/product-detail/microchip-technology/a40mx02-plg44m

2 40MX and 42MX FPGA Families

2.1 Features

The following sections list out various features of the 40MX and 42MX FPGA family devices.

2.1.1 High Capacity

- Single-Chip ASIC Alternative
- 3,000 to 54,000 System Gates
- Up to 2.5 kbits Configurable Dual-Port SRAM
- Fast Wide-Decode Circuitry
- Up to 202 User-Programmable I/O Pins

2.1.2 High Performance

- 5.6 ns Clock-to-Out
- 250 MHz Performance
- 5 ns Dual-Port SRAM Access
- 100 MHz FIFOs
- 7.5 ns 35-Bit Address Decode

2.1.3 HiRel Features

- Commercial, Industrial, Automotive, and Military Temperature Plastic Packages
- Commercial, Military Temperature, and MIL-STD-883 Ceramic Packages
- QML Certification
- Ceramic Devices Available to DSCC SMD

2.1.4 Ease of Integration

- Mixed-Voltage Operation (5.0 V or 3.3 V for core and I/Os), with PCI-Compliant I/Os
- Up to 100% Resource Utilization and 100% Pin Locking
- Deterministic, User-Controllable Timing
- Unique In-System Diagnostic and Verification Capability with Silicon Explorer II
- Low Power Consumption
- IEEE Standard 1149.1 (JTAG) Boundary Scan Testing

2.2 Product Profile

The following table gives the features of the products.

Table 1 • Product profile

Device	A40MX02	A40MX04	A42MX09	A42MX16	A42MX24	A42MX36
Capacity						
System Gates	3,000	6,000	14,000	24,000	36,000	54,000
SRAM Bits	–	–	–	–	–	2,560
Logic Modules						
Sequential	–	–	348	624	954	1,230
Combinatorial	295	547	336	608	912	1,184
Decode	–	–	–	–	24	24
Clock-to-Out	9.5 ns	9.5 ns	5.6 ns	6.1 ns	6.1 ns	6.3 ns
SRAM Modules (64x4 or 32x8)						
	–	–	–	–	–	10
Dedicated Flip-Flops	–	–	348	624	954	1,230

Designer software development tools provide a design library of I/O macro functions that can implement all I/O configurations supported by the MX FPGAs.

Figure 10 • 42MX I/O Module

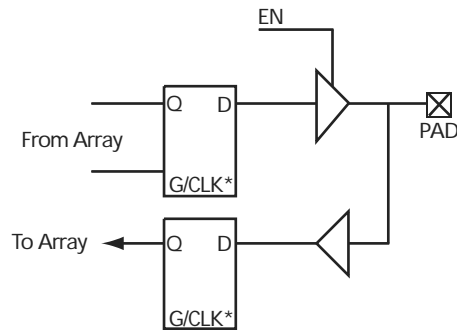

Note: *Can be configured as a Latch or D Flip-Flop (Using C-Module)

Figure 11 • PCI Output Structure of A42MX24 and A42MX36 Devices

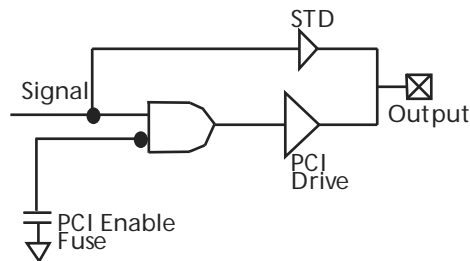

3.3 Other Architectural Features

The following sections cover other architectural features of 40MX and 42MX FPGAs.

3.3.1 Performance

MX devices can operate with internal clock frequencies of 250 MHz, enabling fast execution of complex logic functions. MX devices are live on power-up and do not require auxiliary configuration devices and thus are an optimal platform to integrate the functionality contained in multiple programmable logic devices. In addition, designs that previously would have required a gate array to meet performance can be integrated into an MX device with improvements in cost and time-to-market. Using timing-driven place-and-route (TDPR) tools, designers can achieve highly deterministic device performance.

3.3.2 User Security

Microsemi FuseLock provides robust security against design theft. Special security fuses are hidden in the fabric of the device and protect against unauthorized users attempting to access the programming and/or probe interfaces. It is virtually impossible to identify or bypass these fuses without damaging the device, making Microsemi antifuse FPGAs protected with the highest level of security available from both invasive and noninvasive attacks.

Special security fuses in 40MX devices include the Probe Fuse and Program Fuse. The former disables the probing circuitry while the latter prohibits further programming of all fuses, including the Probe Fuse. In 42MX devices, there is the Security Fuse which, when programmed, both disables the probing circuitry and prohibits further programming of the device.

3.3.3 Programming

Device programming is supported through the Silicon Sculptor series of programmers. Silicon Sculptor is a compact, robust, single-site and multi-site device programmer for the PC. With standalone software, Silicon Sculptor is designed to allow concurrent programming of multiple units from the same PC.

Figure 20 • 42MX Timing Model (SRAM Functions)

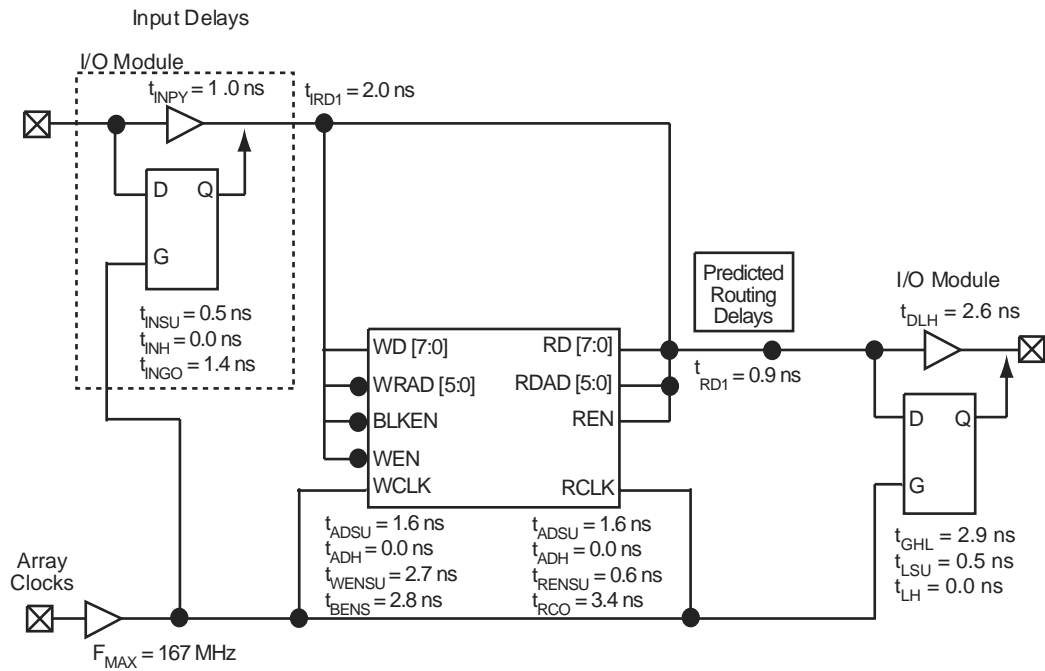

Note: Values are shown for A42MX36 –3 at 5.0 V worst-case commercial conditions.

3.10.1 Parameter Measurement

The following figures show parameter measurement details.

Figure 21 • Output Buffer Delays

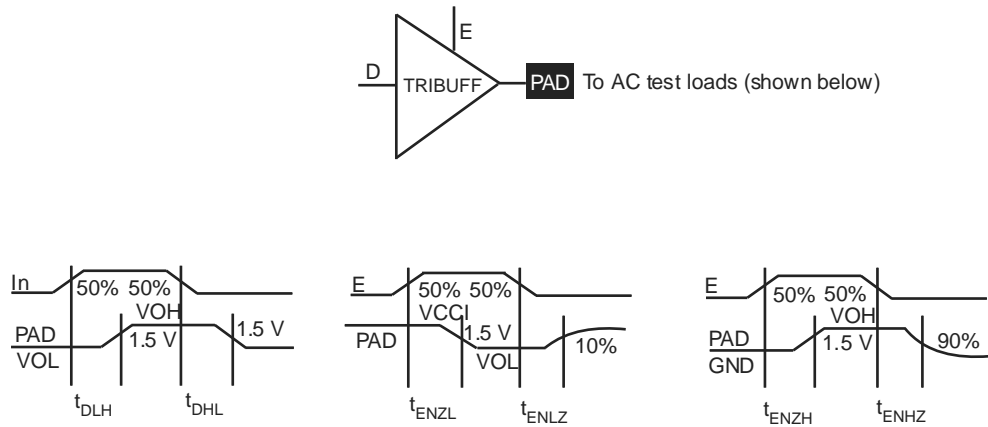

Table 35 • A40MX02 Timing Characteristics (Nominal 3.3 V Operation) (continued)
(Worst-Case Commercial Conditions, VCC = 3.0 V, T_J = 70°C)

Parameter / Description	-3 Speed		-2 Speed		-1 Speed		Std Speed		-F Speed		Units
	Min.	Max.	Min.	Max.	Min.	Max.	Min.	Max.	Min.	Max.	
CMOS Output Module Timing⁴											
t _{DLH}	Data-to-Pad HIGH	5.5	6.4	7.2	8.5	11.9	ns				
t _{DHL}	Data-to-Pad LOW	4.8	5.5	6.2	7.3	10.2	ns				
t _{ENZH}	Enable Pad Z to HIGH	4.7	5.5	6.2	7.3	10.2	ns				
t _{ENZL}	Enable Pad Z to LOW	6.8	7.9	8.9	10.5	14.7	ns				
t _{ENHZ}	Enable Pad HIGH to Z	11.1	12.8	14.5	17.1	23.9	ns				
t _{ENLZ}	Enable Pad LOW to Z	8.2	9.5	10.7	12.6	17.7	ns				
d _{TLH}	Delta LOW to HIGH	0.05	0.05	0.06	0.07	0.10	ns/pF				
d _{THL}	Delta HIGH to LOW	0.03	0.03	0.04	0.04	0.06	ns/pF				

1. Routing delays are for typical designs across worst-case operating conditions. These parameters should be used for estimating device performance. Post-route timing analysis or simulation is required to determine actual performance.
2. Set-up times assume fanout of 3. Further testing information can be obtained from the Timer utility.
3. The hold time for the DFME1A macro may be greater than 0 ns. Use the Timer tool from the Designer software to check the hold time for this macro
4. Delays based on 35 pF loading

Table 36 • A40MX04 Timing Characteristics (Nominal 5.0 V Operation) (Worst-Case Commercial Conditions, VCC = 4.75 V, T_J = 70°C)

Parameter / Description	-3 Speed		-2 Speed		-1 Speed		Std Speed		-F Speed		Units
	Min.	Max.	Min.	Max.	Min.	Max.	Min.	Max.	Min.	Max.	
Logic Module Propagation Delays											
t _{PD1}	Single Module	1.2	1.4	1.6	1.9	2.7	ns				
t _{PD2}	Dual-Module Macros	2.3	3.1	3.5	4.1	5.7	ns				
t _{CO}	Sequential Clock-to-Q	1.2	1.4	1.6	1.9	2.7	ns				
t _{GO}	Latch G-to-Q	1.2	1.4	1.6	1.9	2.7	ns				
t _{RS}	Flip-Flop (Latch) Reset-to-Q	1.2	1.4	1.6	1.9	2.7	ns				
Logic Module Predicted Routing Delays¹											
t _{RD1}	FO = 1 Routing Delay	1.2	1.6	1.8	2.1	3.0	ns				
t _{RD2}	FO = 2 Routing Delay	1.9	2.2	2.5	2.9	4.1	ns				
t _{RD3}	FO = 3 Routing Delay	2.4	2.8	3.2	3.7	5.2	ns				
t _{RD4}	FO = 4 Routing Delay	2.9	3.4	3.9	4.5	6.3	ns				
t _{RD8}	FO = 8 Routing Delay	5.0	5.8	6.6	7.8	10.9	ns				
Logic Module Sequential Timing²											
t _{SUD}	Flip-Flop (Latch) Data Input Set-Up	3.1	3.5	4.0	4.7	6.6	ns				
t _{HD} ³	Flip-Flop (Latch) Data Input Hold	0.0	0.0	0.0	0.0	0.0	ns				
t _{SUENA}	Flip-Flop (Latch) Enable Set-Up	3.1	3.5	4.0	4.7	6.6	ns				

Table 44 • A42MX36 Timing Characteristics (Nominal 5.0 V Operation)(Worst-Case Commercial Conditions, VCCA = 4.75 V, T_J = 70°C)

Parameter / Description	-3 Speed		-2 Speed		-1 Speed		Std Speed		-F Speed		Units
	Min.	Max.	Min.	Max.	Min.	Max.	Min.	Max.	Min.	Max.	
TTL Output Module Timing⁵ (Continued)											
t _{ENLZ}	Enable Pad LOW to Z		4.9	5.5	6.2	7.3	10.2	ns			
t _{GLH}	G-to-Pad HIGH		2.9	3.3	3.7	4.4	6.1	ns			
t _{GHL}	G-to-Pad LOW		2.9	3.3	3.7	4.4	6.1	ns			
t _{LSU}	I/O Latch Output Set-Up		0.5	0.5	0.6	0.7	1.0	ns			
t _{LH}	I/O Latch Output Hold		0.0	0.0	0.0	0.0	0.0	ns			
t _{LCO}	I/O Latch Clock-to-Out (Pad-to-Pad) 32 I/O		5.7	6.3	7.1	8.4	11.8	ns			
t _{ACO}	Array Latch Clock-to-Out (Pad-to-Pad) 32 I/O		7.8	8.6	9.8	11.5	16.1	ns			
d _{TLH}	Capacitive Loading, LOW to HIGH		0.07	0.08	0.09	0.10	0.14	ns/pF			
d _{THL}	Capacitive Loading, HIGH to LOW		0.07	0.08	0.09	0.10	0.14	ns/pF			

4 Package Pin Assignments

The following figures and tables give the details of the package pin assignments.

Figure 38 • PL44

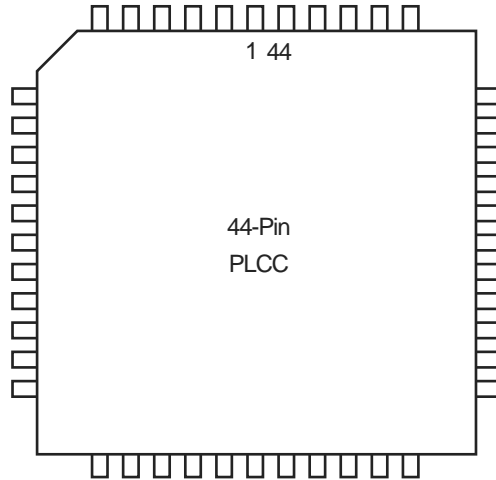

Table 47 • PL44

PL44		
Pin Number	A40MX02 Function	A40MX04 Function
1	I/O	I/O
2	I/O	I/O
3	VCC	VCC
4	I/O	I/O
5	I/O	I/O
6	I/O	I/O
7	I/O	I/O
8	I/O	I/O
9	I/O	I/O
10	GND	GND
11	I/O	I/O
12	I/O	I/O
13	I/O	I/O
14	VCC	VCC
15	I/O	I/O
16	VCC	VCC
17	I/O	I/O
18	I/O	I/O
19	I/O	I/O
20	I/O	I/O

Table 47 • PL44

PL44		
Pin Number	A40MX02 Function	A40MX04 Function
21	GND	GND
22	I/O	I/O
23	I/O	I/O
24	I/O	I/O
25	VCC	VCC
26	I/O	I/O
27	I/O	I/O
28	I/O	I/O
29	I/O	I/O
30	I/O	I/O
31	I/O	I/O
32	GND	GND
33	CLK, I/O	CLK, I/O
34	MODE	MODE
35	VCC	VCC
36	SDI, I/O	SDI, I/O
37	DCLK, I/O	DCLK, I/O
38	PRA, I/O	PRA, I/O
39	PRB, I/O	PRB, I/O
40	I/O	I/O
41	I/O	I/O
42	I/O	I/O
43	GND	GND
44	I/O	I/O

Table 49 • PL84

PL84				
Pin Number	A40MX04 Function	A42MX09 Function	A42MX16 Function	A42MX24 Function
47	I/O	I/O	I/O	WD, I/O
48	I/O	I/O	I/O	I/O
49	I/O	GND	GND	GND
50	I/O	I/O	I/O	WD, I/O
51	I/O	I/O	I/O	WD, I/O
52	I/O	SDO, I/O	SDO, I/O	SDO, TDO, I/O
53	I/O	I/O	I/O	I/O
54	I/O	I/O	I/O	I/O
55	I/O	I/O	I/O	I/O
56	I/O	I/O	I/O	I/O
57	I/O	I/O	I/O	I/O
58	I/O	I/O	I/O	I/O
59	I/O	I/O	I/O	I/O
60	GND	I/O	I/O	I/O
61	GND	I/O	I/O	I/O
62	I/O	I/O	I/O	TCK, I/O
63	I/O	LP	LP	LP
64	CLK, I/O	VCCA	VCCA	VCCA
65	I/O	VCCI	VCCI	VCCI
66	MODE	I/O	I/O	I/O
67	VCC	I/O	I/O	I/O
68	VCC	I/O	I/O	I/O
69	I/O	I/O	I/O	I/O
70	I/O	GND	GND	GND
71	I/O	I/O	I/O	I/O
72	SDI, I/O	I/O	I/O	I/O
73	DCLK, I/O	I/O	I/O	I/O
74	PRA, I/O	I/O	I/O	I/O
75	PRB, I/O	I/O	I/O	I/O
76	I/O	SDI, I/O	SDI, I/O	SDI, I/O
77	I/O	I/O	I/O	I/O
78	I/O	I/O	I/O	WD, I/O
79	I/O	I/O	I/O	WD, I/O
80	I/O	I/O	I/O	WD, I/O
81	I/O	PRA, I/O	PRA, I/O	PRA, I/O
82	GND	I/O	I/O	I/O
83	I/O	CLKA, I/O	CLKA, I/O	CLKA, I/O

Table 50 • PQ 100

PQ100				
Pin Number	A40MX02 Function	A40MX04 Function	A42MX09 Function	A42MX16 Function
19	VCC	V _{CC}	I/O	I/O
20	I/O	I/O	I/O	I/O
21	I/O	I/O	I/O	I/O
22	I/O	I/O	GND	GND
23	I/O	I/O	I/O	I/O
24	I/O	I/O	I/O	I/O
25	I/O	I/O	I/O	I/O
26	I/O	I/O	I/O	I/O
27	NC	NC	I/O	I/O
28	NC	NC	I/O	I/O
29	NC	NC	I/O	I/O
30	NC	NC	I/O	I/O
31	NC	I/O	I/O	I/O
32	NC	I/O	I/O	I/O
33	NC	I/O	I/O	I/O
34	I/O	I/O	GND	GND
35	I/O	I/O	I/O	I/O
36	GND	GND	I/O	I/O
37	GND	GND	I/O	I/O
38	I/O	I/O	I/O	I/O
39	I/O	I/O	I/O	I/O
40	I/O	I/O	VCCA	VCCA
41	I/O	I/O	I/O	I/O
42	I/O	I/O	I/O	I/O
43	VCC	VCC	I/O	I/O
44	VCC	VCC	I/O	I/O
45	I/O	I/O	I/O	I/O
46	I/O	I/O	GND	GND
47	I/O	I/O	I/O	I/O
48	NC	I/O	I/O	I/O
49	NC	I/O	I/O	I/O
50	NC	I/O	I/O	I/O
51	NC	NC	I/O	I/O
52	NC	NC	SDO, I/O	SDO, I/O
53	NC	NC	I/O	I/O
54	NC	NC	I/O	I/O
55	NC	NC	I/O	I/O

Table 50 • PQ 100

PQ100				
Pin Number	A40MX02 Function	A40MX04 Function	A42MX09 Function	A42MX16 Function
93	VCC	VCC	I/O	I/O
94	VCC	VCC	PRB, I/O	PRB, I/O
95	NC	I/O	I/O	I/O
96	NC	I/O	GND	GND
97	NC	I/O	I/O	I/O
98	SDI, I/O	SDI, I/O	I/O	I/O
99	DCLK, I/O	DCLK, I/O	I/O	I/O
100	PRA, I/O	PRA, I/O	I/O	I/O

Table 51 • PQ144

PQ144	
Pin Number	A42MX09 Function
43	I/O
44	GNDQ
45	GNDI
46	NC
47	I/O
48	I/O
49	I/O
50	I/O
51	I/O
52	I/O
53	I/O
54	VCC
55	VCCI
56	NC
57	I/O
58	I/O
59	I/O
60	I/O
61	I/O
62	I/O
63	I/O
64	GND
65	GNDI
66	I/O
67	I/O
68	I/O
69	I/O
70	I/O
71	SDO
72	I/O
73	I/O
74	I/O
75	I/O
76	I/O
77	I/O
78	I/O
79	GNDQ

Table 51 • PQ144

PQ144	
Pin Number	A42MX09 Function
117	GNDI
118	NC
119	I/O
120	I/O
121	I/O
122	I/O
123	PROBA
124	I/O
125	CLKA
126	VCC
127	VCCI
128	NC
129	I/O
130	CLKB
131	I/O
132	PROBB
133	I/O
134	I/O
135	I/O
136	GND
137	GNDI
138	NC
139	I/O
140	I/O
141	I/O
142	I/O
143	I/O
144	DCLK

Table 53 • PQ208

PQ208			
Pin Number	A42MX16 Function	A42MX24 Function	A42MX36 Function
206	I/O	I/O	I/O
207	DCLK, I/O	DCLK, I/O	DCLK, I/O
208	I/O	I/O	I/O

Figure 45 • PQ240

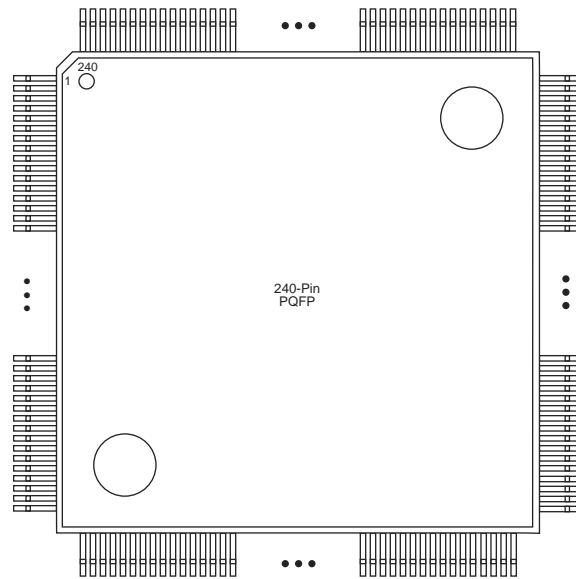

Note: This figure shows the 240-Pin PQFP Package top view.

Table 54 • PQ240

PQ240	
Pin Number	A42MX36 Function
1	I/O
2	DCLK, I/O
3	I/O
4	I/O
5	I/O
6	WD, I/O
7	WD, I/O
8	VCCI
9	I/O
10	I/O
11	I/O
12	I/O
13	I/O
14	I/O

Table 54 • PQ240

PQ240	
Pin Number	A42MX36 Function
89	VCCI
90	VCCA
91	LP
92	TCK, I/O
93	I/O
94	GND
95	I/O
96	I/O
97	I/O
98	I/O
99	I/O
100	I/O
101	I/O
102	I/O
103	I/O
104	I/O
105	I/O
106	I/O
107	I/O
108	VCCI
109	I/O
110	I/O
111	I/O
112	I/O
113	I/O
114	I/O
115	I/O
116	I/O
117	I/O
118	VCCA
119	GND
120	GND
121	GND
122	I/O
123	SDO, TDO, I/O
124	I/O
125	WD, I/O

Table 54 • PQ240

PQ240	
Pin Number	A42MX36 Function
200	I/O
201	I/O
202	I/O
203	I/O
204	I/O
205	I/O
206	VCCA
207	I/O
208	I/O
209	VCCA
210	VCCI
211	I/O
212	I/O
213	I/O
214	I/O
215	I/O
216	I/O
217	I/O
218	I/O
219	VCCA
220	I/O
221	I/O
222	I/O
223	I/O
224	I/O
225	I/O
226	I/O
227	VCCI
228	I/O
229	I/O
230	I/O
231	I/O
232	I/O
233	I/O
234	I/O
235	I/O
236	I/O

Figure 47 • VQ100

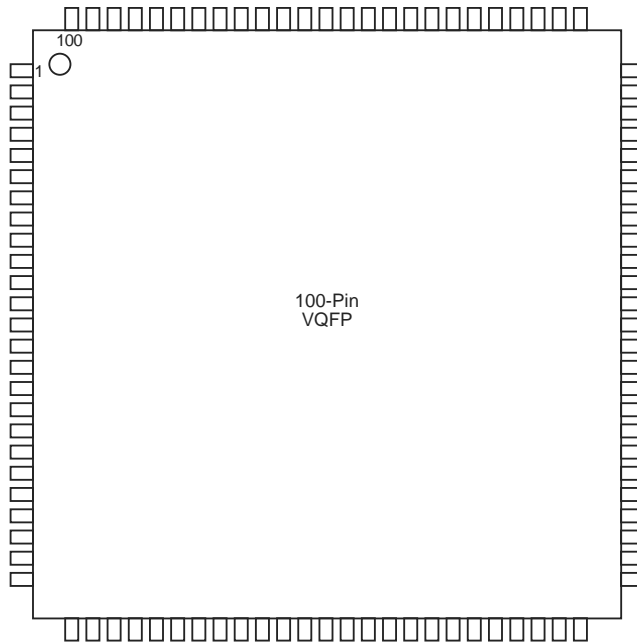

Table 56 • VQ100

VQ100		
Pin Number	A42MX09 Function	A42MX16 Function
1	I/O	I/O
2	MODE	MODE
3	I/O	I/O
4	I/O	I/O
5	I/O	I/O
6	I/O	I/O
7	GND	GND
8	I/O	I/O
9	I/O	I/O
10	I/O	I/O
11	I/O	I/O
12	I/O	I/O
13	I/O	I/O
14	VCCA	NC
15	VCCI	VCCI
16	I/O	I/O
17	I/O	I/O
18	I/O	I/O
19	I/O	I/O
20	GND	GND

Table 57 • TQ176

TQ176			
Pin Number	A42MX09 Function	A42MX16 Function	A42MX24 Function
158	CLKB, I/O	CLKB, I/O	CLKB, I/O
159	I/O	I/O	I/O
160	PRB, I/O	PRB, I/O	PRB, I/O
161	NC	I/O	WD, I/O
162	I/O	I/O	WD, I/O
163	I/O	I/O	I/O
164	I/O	I/O	I/O
165	NC	NC	WD, I/O
166	NC	I/O	WD, I/O
167	I/O	I/O	I/O
168	NC	I/O	I/O
169	I/O	I/O	I/O
170	NC	VCCI	VCCI
171	I/O	I/O	WD, I/O
172	I/O	I/O	WD, I/O
173	NC	I/O	I/O
174	I/O	I/O	I/O
175	DCLK, I/O	DCLK, I/O	DCLK, I/O
176	I/O	I/O	I/O

Figure 49 • CQ208

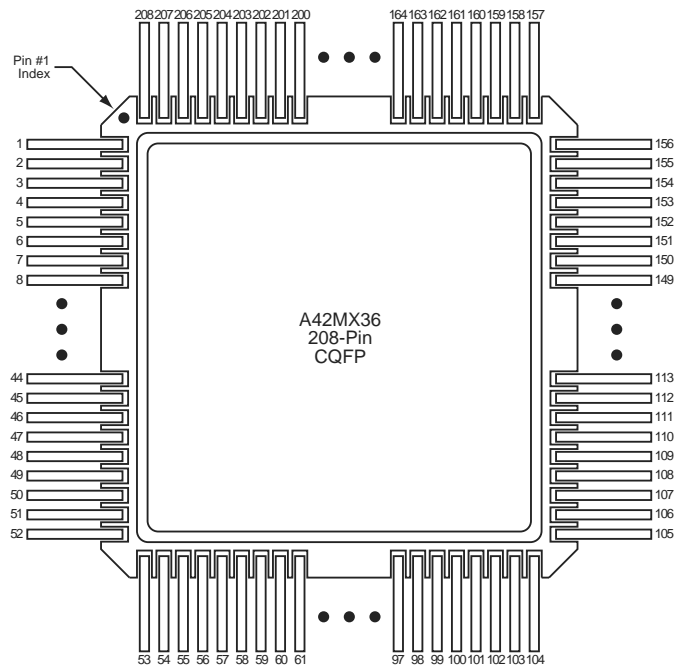

Table 60 • BG272

BG272	
Pin Number	A42MX36 Function
J9	GND
J10	GND
J11	GND
J12	GND
J17	VCCA
J18	I/O
J19	I/O
J20	I/O
K1	I/O
K2	I/O
K3	I/O
K4	VCCI
K9	GND
K10	GND
K11	GND
K12	GND
K17	I/O
K18	VCCA
K19	VCCA
K20	LP
L1	I/O
L2	I/O
L3	VCCA
L4	VCCA
L9	GND
L10	GND
L11	GND
L12	GND
L17	VCCI
L18	I/O
L19	I/O
L20	TCK, I/O
M1	I/O
M2	I/O
M3	I/O
M4	VCCI
M9	GND

Figure 53 • CQ172**Table 62 • CQ172**

CQ172	
Pin Number	A42MX16 Function
1	MODE
2	I/O
3	I/O
4	I/O
5	I/O
6	I/O
7	GND
8	I/O
9	I/O
10	I/O
11	I/O
12	VCC
13	I/O
14	I/O
15	I/O
16	I/O
17	GND
18	I/O
19	I/O
20	I/O

Table 62 • CQ172

21	I/O
22	GND
23	VCCI
24	VSV
25	I/O
26	I/O
27	VCC
28	I/O
29	I/O
30	I/O
31	I/O
32	GND
33	I/O
34	I/O
35	I/O
36	I/O
37	GND
38	I/O
39	I/O
40	I/O
41	I/O
42	I/O
43	I/O
44	BININ
45	BINOUT
46	I/O
47	I/O
48	I/O
49	I/O
50	VCCI
51	I/O
52	I/O
53	I/O
54	I/O
55	GND
56	I/O
57	I/O
58	I/O
59	I/O