

Welcome to [E-XFL.COM](https://www.e-xfl.com)

Understanding Embedded - FPGAs (Field Programmable Gate Array)

Embedded - FPGAs, or Field Programmable Gate Arrays, are advanced integrated circuits that offer unparalleled flexibility and performance for digital systems. Unlike traditional fixed-function logic devices, FPGAs can be programmed and reprogrammed to execute a wide array of logical operations, enabling customized functionality tailored to specific applications. This reprogrammability allows developers to iterate designs quickly and implement complex functions without the need for custom hardware.

Applications of Embedded - FPGAs

The versatility of Embedded - FPGAs makes them indispensable in numerous fields. In telecommunications.

Details

Product Status	Active
Number of LABs/CLBs	-
Number of Logic Elements/Cells	-
Total RAM Bits	-
Number of I/O	508
Number of Gates	-
Voltage - Supply	1.71V ~ 1.89V
Mounting Type	Surface Mount
Operating Temperature	0°C ~ 85°C (TJ)
Package / Case	672-BBGA
Supplier Device Package	672-FBGA (27x27)
Purchase URL	https://www.e-xfl.com/pro/item?MUrl=&PartUrl=ep20k1000efc672-1

Table 5. APEX 20K FineLine BGA Package Options & I/O Count *Notes (1), (2)*

Device	144 Pin	324 Pin	484 Pin	672 Pin	1,020 Pin
EP20K30E	93	128			
EP20K60E	93	196			
EP20K100		252			
EP20K100E	93	246			
EP20K160E			316		
EP20K200			382		
EP20K200E			376	376	
EP20K300E				408	
EP20K400				502 (3)	
EP20K400E				488 (3)	
EP20K600E				508 (3)	588
EP20K1000E				508 (3)	708
EP20K1500E					808

Notes to Tables 4 and 5:

- (1) I/O counts include dedicated input and clock pins.
- (2) APEX 20K device package types include thin quad flat pack (TQFP), plastic quad flat pack (PQFP), power quad flat pack (RQFP), 1.27-mm pitch ball-grid array (BGA), 1.00-mm pitch FineLine BGA, and pin-grid array (PGA) packages.
- (3) This device uses a thermally enhanced package, which is taller than the regular package. Consult the *Altera Device Package Information Data Sheet* for detailed package size information.

Table 6. APEX 20K QFP, BGA & PGA Package Sizes

Feature	144-Pin TQFP	208-Pin QFP	240-Pin QFP	356-Pin BGA	652-Pin BGA	655-Pin PGA
Pitch (mm)	0.50	0.50	0.50	1.27	1.27	–
Area (mm ²)	484	924	1,218	1,225	2,025	3,906
Length × Width (mm × mm)	22 × 22	30.4 × 30.4	34.9 × 34.9	35 × 35	45 × 45	62.5 × 62.5

Table 7. APEX 20K FineLine BGA Package Sizes

Feature	144 Pin	324 Pin	484 Pin	672 Pin	1,020 Pin
Pitch (mm)	1.00	1.00	1.00	1.00	1.00
Area (mm ²)	169	361	529	729	1,089
Length × Width (mm × mm)	13 × 13	19 × 19	23 × 23	27 × 27	33 × 33

All APEX 20K devices are reconfigurable and are 100% tested prior to shipment. As a result, test vectors do not have to be generated for fault coverage purposes. Instead, the designer can focus on simulation and design verification. In addition, the designer does not need to manage inventories of different application-specific integrated circuit (ASIC) designs; APEX 20K devices can be configured on the board for the specific functionality required.

APEX 20K devices are configured at system power-up with data stored in an Altera serial configuration device or provided by a system controller. Altera offers in-system programmability (ISP)-capable EPC1, EPC2, and EPC16 configuration devices, which configure APEX 20K devices via a serial data stream. Moreover, APEX 20K devices contain an optimized interface that permits microprocessors to configure APEX 20K devices serially or in parallel, and synchronously or asynchronously. The interface also enables microprocessors to treat APEX 20K devices as memory and configure the device by writing to a virtual memory location, making reconfiguration easy.

After an APEX 20K device has been configured, it can be reconfigured in-circuit by resetting the device and loading new data. Real-time changes can be made during system operation, enabling innovative reconfigurable computing applications.

APEX 20K devices are supported by the Altera Quartus II development system, a single, integrated package that offers HDL and schematic design entry, compilation and logic synthesis, full simulation and worst-case timing analysis, SignalTap logic analysis, and device configuration. The Quartus II software runs on Windows-based PCs, Sun SPARCstations, and HP 9000 Series 700/800 workstations.

The Quartus II software provides NativeLink interfaces to other industry-standard PC- and UNIX workstation-based EDA tools. For example, designers can invoke the Quartus II software from within third-party design tools. Further, the Quartus II software contains built-in optimized synthesis libraries; synthesis tools can use these libraries to optimize designs for APEX 20K devices. For example, the Synopsys Design Compiler library, supplied with the Quartus II development system, includes DesignWare functions optimized for the APEX 20K architecture.

APEX 20K devices provide two dedicated clock pins and four dedicated input pins that drive register control inputs. These signals ensure efficient distribution of high-speed, low-skew control signals. These signals use dedicated routing channels to provide short delays and low skews. Four of the dedicated inputs drive four global signals. These four global signals can also be driven by internal logic, providing an ideal solution for a clock divider or internally generated asynchronous clear signals with high fan-out. The dedicated clock pins featured on the APEX 20K devices can also feed logic. The devices also feature ClockLock and ClockBoost clock management circuitry. APEX 20KE devices provide two additional dedicated clock pins, for a total of four dedicated clock pins.

MegaLAB Structure

APEX 20K devices are constructed from a series of MegaLAB™ structures. Each MegaLAB structure contains a group of logic array blocks (LABs), one ESB, and a MegaLAB interconnect, which routes signals within the MegaLAB structure. The EP20K30E device has 10 LABs, EP20K60E through EP20K600E devices have 16 LABs, and the EP20K1000E and EP20K1500E devices have 24 LABs. Signals are routed between MegaLAB structures and I/O pins via the FastTrack Interconnect. In addition, edge LABs can be driven by I/O pins through the local interconnect. Figure 2 shows the MegaLAB structure.

Figure 2. MegaLAB Structure

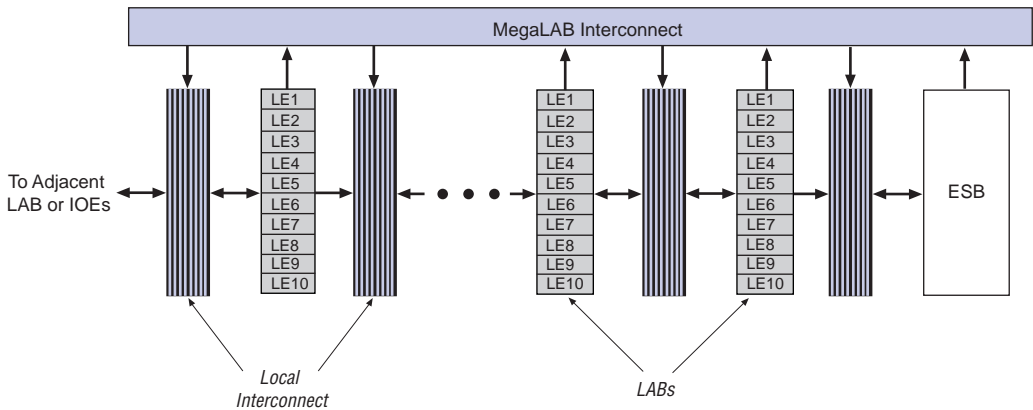

Logic Array Block

Each LAB consists of 10 LEs, the LEs' associated carry and cascade chains, LAB control signals, and the local interconnect. The local interconnect transfers signals between LEs in the same or adjacent LABs, IOEs, or ESBs. The Quartus II Compiler places associated logic within an LAB or adjacent LABs, allowing the use of a fast local interconnect for high performance. Figure 3 shows the APEX 20K LAB.

APEX 20K devices use an interleaved LAB structure. This structure allows each LE to drive two local interconnect areas. This feature minimizes use of the MegaLAB and FastTrack interconnect, providing higher performance and flexibility. Each LE can drive 29 other LEs through the fast local interconnect.

Figure 3. LAB Structure

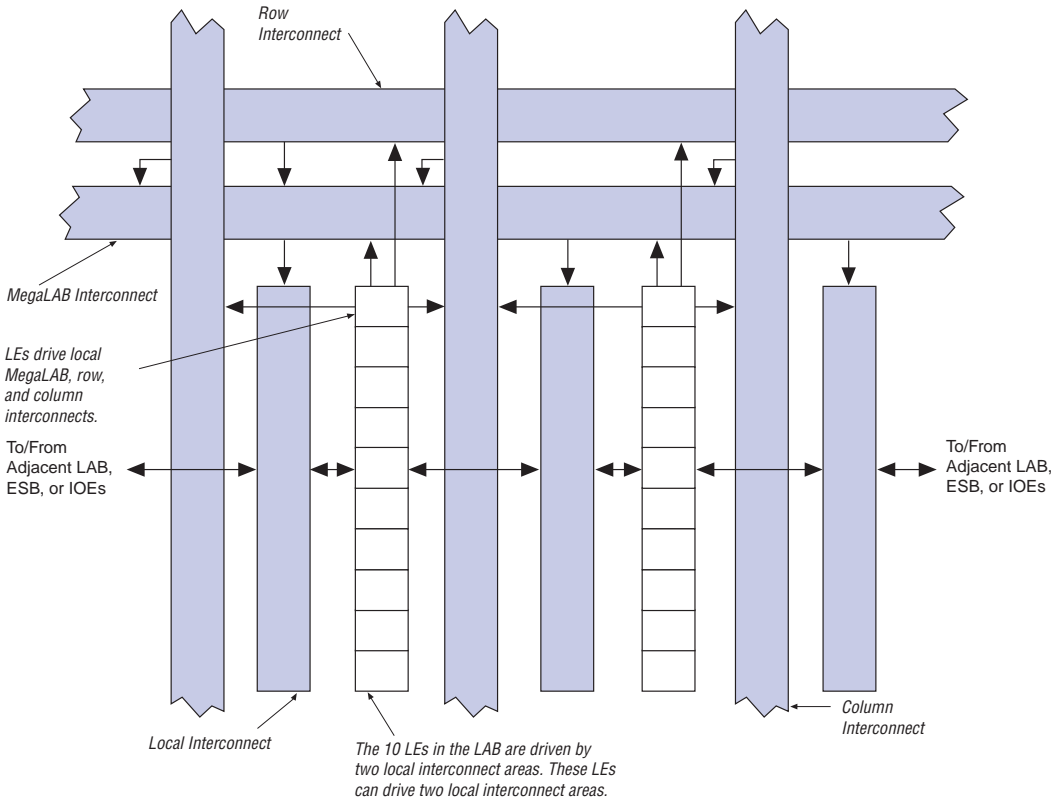

Normal Mode

The normal mode is suitable for general logic applications, combinatorial functions, or wide decoding functions that can take advantage of a cascade chain. In normal mode, four data inputs from the LAB local interconnect and the carry-in are inputs to a four-input LUT. The Quartus II software Compiler automatically selects the carry-in or the DATA3 signal as one of the inputs to the LUT. The LUT output can be combined with the cascade-in signal to form a cascade chain through the cascade-out signal. LEs in normal mode support packed registers.

Arithmetic Mode

The arithmetic mode is ideal for implementing adders, accumulators, and comparators. An LE in arithmetic mode uses two 3-input LUTs. One LUT computes a three-input function; the other generates a carry output. As shown in [Figure 8](#), the first LUT uses the carry-in signal and two data inputs from the LAB local interconnect to generate a combinatorial or registered output. For example, when implementing an adder, this output is the sum of three signals: DATA1, DATA2, and carry-in. The second LUT uses the same three signals to generate a carry-out signal, thereby creating a carry chain. The arithmetic mode also supports simultaneous use of the cascade chain. LEs in arithmetic mode can drive out registered and unregistered versions of the LUT output.

The Quartus II software implements parameterized functions that use the arithmetic mode automatically where appropriate; the designer does not need to specify how the carry chain will be used.

Counter Mode

The counter mode offers clock enable, counter enable, synchronous up/down control, synchronous clear, and synchronous load options. The counter enable and synchronous up/down control signals are generated from the data inputs of the LAB local interconnect. The synchronous clear and synchronous load options are LAB-wide signals that affect all registers in the LAB. Consequently, if any of the LEs in an LAB use the counter mode, other LEs in that LAB must be used as part of the same counter or be used for a combinatorial function. The Quartus II software automatically places any registers that are not used by the counter into other LABs.

The counter mode uses two three-input LUTs: one generates the counter data, and the other generates the fast carry bit. A 2-to-1 multiplexer provides synchronous loading, and another AND gate provides synchronous clearing. If the cascade function is used by an LE in counter mode, the synchronous clear or load overrides any signal carried on the cascade chain. The synchronous clear overrides the synchronous load. LEs in arithmetic mode can drive out registered and unregistered versions of the LUT output.

Clear & Preset Logic Control

Logic for the register's clear and preset signals is controlled by LAB-wide signals. The LE directly supports an asynchronous clear function. The Quartus II software Compiler can use a NOT-gate push-back technique to emulate an asynchronous preset. Moreover, the Quartus II software Compiler can use a programmable NOT-gate push-back technique to emulate simultaneous preset and clear or asynchronous load. However, this technique uses three additional LEs per register. All emulation is performed automatically when the design is compiled. Registers that emulate simultaneous preset and load will enter an unknown state upon power-up or when the chip-wide reset is asserted.

In addition to the two clear and preset modes, APEX 20K devices provide a chip-wide reset pin (`DEV_CLRn`) that resets all registers in the device. Use of this pin is controlled through an option in the Quartus II software that is set before compilation. The chip-wide reset overrides all other control signals. Registers using an asynchronous preset are preset when the chip-wide reset is asserted; this effect results from the inversion technique used to implement the asynchronous preset.

FastTrack Interconnect

In the APEX 20K architecture, connections between LEs, ESBs, and I/O pins are provided by the FastTrack Interconnect. The FastTrack Interconnect is a series of continuous horizontal and vertical routing channels that traverse the device. This global routing structure provides predictable performance, even in complex designs. In contrast, the segmented routing in FPGAs requires switch matrices to connect a variable number of routing paths, increasing the delays between logic resources and reducing performance.

The FastTrack Interconnect consists of row and column interconnect channels that span the entire device. The row interconnect routes signals throughout a row of MegaLAB structures; the column interconnect routes signals throughout a column of MegaLAB structures. When using the row and column interconnect, an LE, IOE, or ESB can drive any other LE, IOE, or ESB in a device. See [Figure 9](#).

Figure 9. APEX 20K Interconnect Structure

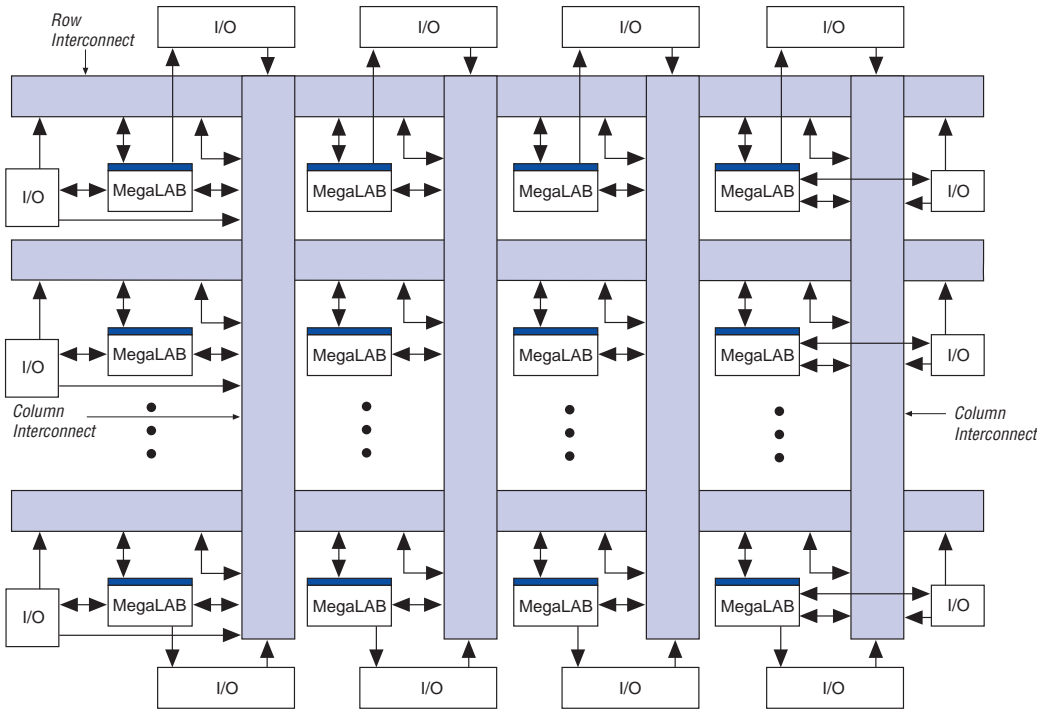

A row line can be driven directly by LEs, IOEs, or ESBs in that row. Further, a column line can drive a row line, allowing an LE, IOE, or ESB to drive elements in a different row via the column and row interconnect. The row interconnect drives the MegaLAB interconnect to drive LEs, IOEs, or ESBs in a particular MegaLAB structure.

A column line can be directly driven by LEs, IOEs, or ESBs in that column. A column line on a device's left or right edge can also be driven by row IOEs. The column line is used to route signals from one row to another. A column line can drive a row line; it can also drive the MegaLAB interconnect directly, allowing faster connections between rows.

Figure 10 shows how the FastTrack Interconnect uses the local interconnect to drive LEs within MegaLAB structures.

Implementing Logic in ROM

In addition to implementing logic with product terms, the ESB can implement logic functions when it is programmed with a read-only pattern during configuration, creating a large LUT. With LUTs, combinatorial functions are implemented by looking up the results, rather than by computing them. This implementation of combinatorial functions can be faster than using algorithms implemented in general logic, a performance advantage that is further enhanced by the fast access times of ESBs. The large capacity of ESBs enables designers to implement complex functions in one logic level without the routing delays associated with linked LEs or distributed RAM blocks. Parameterized functions such as LPM functions can take advantage of the ESB automatically. Further, the Quartus II software can implement portions of a design with ESBs where appropriate.

Programmable Speed/Power Control

APEX 20K ESBs offer a high-speed mode that supports very fast operation on an ESB-by-ESB basis. When high speed is not required, this feature can be turned off to reduce the ESB's power dissipation by up to 50%. ESBs that run at low power incur a nominal timing delay adder. This Turbo Bit™ option is available for ESBs that implement product-term logic or memory functions. An ESB that is not used will be powered down so that it does not consume DC current.

Designers can program each ESB in the APEX 20K device for either high-speed or low-power operation. As a result, speed-critical paths in the design can run at high speed, while the remaining paths operate at reduced power.

I/O Structure

The APEX 20K IOE contains a bidirectional I/O buffer and a register that can be used either as an input register for external data requiring fast setup times, or as an output register for data requiring fast clock-to-output performance. IOEs can be used as input, output, or bidirectional pins. For fast bidirectional I/O timing, LE registers using local routing can improve setup times and OE timing. The Quartus II software Compiler uses the programmable inversion option to invert signals from the row and column interconnect automatically where appropriate. Because the APEX 20K IOE offers one output enable per pin, the Quartus II software Compiler can emulate open-drain operation efficiently.

The APEX 20K IOE includes programmable delays that can be activated to ensure zero hold times, minimum clock-to-output times, input IOE register-to-core register transfers, or core-to-output IOE register transfers. A path in which a pin directly drives a register may require the delay to ensure zero hold time, whereas a path in which a pin drives a register through combinatorial logic may not require the delay.

Figure 26. APEX 20KE Bidirectional I/O Registers Notes (1), (2)

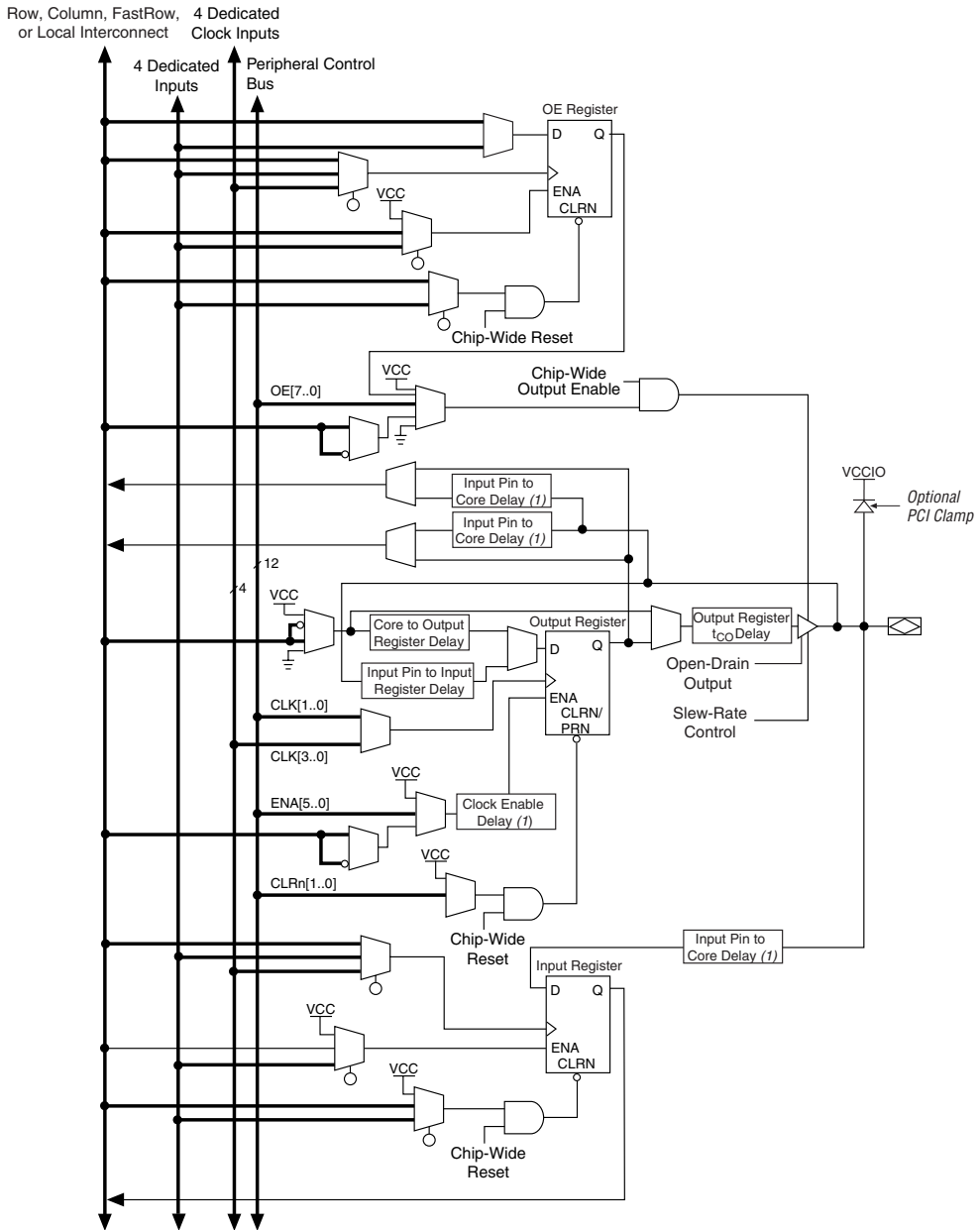

Notes to Figure 26:

- (1) This programmable delay has four settings: off and three levels of delay.
- (2) The output enable and input registers are LE registers in the LAB adjacent to the bidirectional pin.

Notes to Table 16:

- (1) To implement the ClockLock and ClockBoost circuitry with the Quartus II software, designers must specify the input frequency. The Quartus II software tunes the PLL in the ClockLock and ClockBoost circuitry to this frequency. The f_{CLKDEV} parameter specifies how much the incoming clock can differ from the specified frequency during device operation. Simulation does not reflect this parameter.
- (2) Twenty-five thousand parts per million (PPM) equates to 2.5% of input clock period.
- (3) During device configuration, the ClockLock and ClockBoost circuitry is configured before the rest of the device. If the incoming clock is supplied during configuration, the ClockLock and ClockBoost circuitry locks during configuration because the t_{LOCK} value is less than the time required for configuration.
- (4) The t_{JITTER} specification is measured under long-term observation.

Tables 17 and 18 summarize the ClockLock and ClockBoost parameters for APEX 20KE devices.

Table 17. APEX 20KE ClockLock & ClockBoost Parameters <i>Note (1)</i>						
Symbol	Parameter	Conditions	Min	Typ	Max	Unit
t_R	Input rise time				5	ns
t_F	Input fall time				5	ns
t_{INDUTY}	Input duty cycle		40		60	%
$t_{INJITTER}$	Input jitter peak-to-peak				2% of input period	peak-to-peak
$t_{OUTJITTER}$	Jitter on ClockLock or ClockBoost-generated clock				0.35% of output period	RMS
$t_{OUTDUTY}$	Duty cycle for ClockLock or ClockBoost-generated clock		45		55	%
t_{LOCK} (2), (3)	Time required for ClockLock or ClockBoost to acquire lock				40	μ s

Table 18. APEX 20KE Clock Input & Output Parameters (Part 1 of 2) Note (1)

Symbol	Parameter	I/O Standard	-1X Speed Grade		-2X Speed Grade		Units
			Min	Max	Min	Max	
f _{VCO} (4)	Voltage controlled oscillator operating range		200	500	200	500	MHz
f _{CLOCK0}	clock0 PLL output frequency for internal use		1.5	335	1.5	200	MHz
f _{CLOCK1}	clock1 PLL output frequency for internal use		20	335	20	200	MHz
f _{CLOCK0_EXT}	Output clock frequency for external clock0 output	3.3-V LVTTTL	1.5	245	1.5	226	MHz
		2.5-V LVTTTL	1.5	234	1.5	221	MHz
		1.8-V LVTTTL	1.5	223	1.5	216	MHz
		GTL+	1.5	205	1.5	193	MHz
		SSTL-2 Class I	1.5	158	1.5	157	MHz
		SSTL-2 Class II	1.5	142	1.5	142	MHz
		SSTL-3 Class I	1.5	166	1.5	162	MHz
		SSTL-3 Class II	1.5	149	1.5	146	MHz
		LVDS	1.5	420	1.5	350	MHz
f _{CLOCK1_EXT}	Output clock frequency for external clock1 output	3.3-V LVTTTL	20	245	20	226	MHz
		2.5-V LVTTTL	20	234	20	221	MHz
		1.8-V LVTTTL	20	223	20	216	MHz
		GTL+	20	205	20	193	MHz
		SSTL-2 Class I	20	158	20	157	MHz
		SSTL-2 Class II	20	142	20	142	MHz
		SSTL-3 Class I	20	166	20	162	MHz
		SSTL-3 Class II	20	149	20	146	MHz
		LVDS	20	420	20	350	MHz

Table 24. APEX 20K 5.0-V Tolerant Device Recommended Operating Conditions *Note (2)*

Symbol	Parameter	Conditions	Min	Max	Unit
V _{CCINT}	Supply voltage for internal logic and input buffers	(4), (5)	2.375 (2.375)	2.625 (2.625)	V
V _{CCIO}	Supply voltage for output buffers, 3.3-V operation	(4), (5)	3.00 (3.00)	3.60 (3.60)	V
	Supply voltage for output buffers, 2.5-V operation	(4), (5)	2.375 (2.375)	2.625 (2.625)	V
V _I	Input voltage	(3), (6)	-0.5	5.75	V
V _O	Output voltage		0	V _{CCIO}	V
T _J	Junction temperature	For commercial use	0	85	°C
		For industrial use	-40	100	°C
t _R	Input rise time			40	ns
t _F	Input fall time			40	ns

Table 25. APEX 20K 5.0-V Tolerant Device DC Operating Conditions (Part 1 of 2) *Notes (2), (7), (8)*

Symbol	Parameter	Conditions	Min	Typ	Max	Unit
V _{IH}	High-level input voltage		1.7, 0.5 × V _{CCIO} (9)		5.75	V
V _{IL}	Low-level input voltage		-0.5		0.8, 0.3 × V _{CCIO} (9)	V
V _{OH}	3.3-V high-level TTL output voltage	I _{OH} = -8 mA DC, V _{CCIO} = 3.00 V (10)	2.4			V
	3.3-V high-level CMOS output voltage	I _{OH} = -0.1 mA DC, V _{CCIO} = 3.00 V (10)	V _{CCIO} - 0.2			V
	3.3-V high-level PCI output voltage	I _{OH} = -0.5 mA DC, V _{CCIO} = 3.00 to 3.60 V (10)	0.9 × V _{CCIO}			V
	2.5-V high-level output voltage	I _{OH} = -0.1 mA DC, V _{CCIO} = 2.30 V (10)	2.1			V
		I _{OH} = -1 mA DC, V _{CCIO} = 2.30 V (10)	2.0			V
		I _{OH} = -2 mA DC, V _{CCIO} = 2.30 V (10)	1.7			V



For DC Operating Specifications on APEX 20KE I/O standards, please refer to *Application Note 117 (Using Selectable I/O Standards in Altera Devices)*.

Table 30. APEX 20KE Device Capacitance Note (15)

Symbol	Parameter	Conditions	Min	Max	Unit
C _{IN}	Input capacitance	V _{IN} = 0 V, f = 1.0 MHz		8	pF
C _{INCLK}	Input capacitance on dedicated clock pin	V _{IN} = 0 V, f = 1.0 MHz		12	pF
C _{OUT}	Output capacitance	V _{OUT} = 0 V, f = 1.0 MHz		8	pF

Notes to Tables 27 through 30:

- (1) See the *Operating Requirements for Altera Devices Data Sheet*.
- (2) Minimum DC input is -0.5 V. During transitions, the inputs may undershoot to -2.0 V or overshoot to 5.75 V for input currents less than 100 mA and periods shorter than 20 ns.
- (3) Numbers in parentheses are for industrial-temperature-range devices.
- (4) Maximum V_{CC} rise time is 100 ms, and V_{CC} must rise monotonically.
- (5) Minimum DC input is -0.5 V. During transitions, the inputs may undershoot to -2.0 V or overshoot to the voltage shown in the following table based on input duty cycle for input currents less than 100 mA. The overshoot is dependent upon duty cycle of the signal. The DC case is equivalent to 100% duty cycle.

V _{in}	Max. Duty Cycle
4.0V	100% (DC)
4.1	90%
4.2	50%
4.3	30%
4.4	17%
4.5	10%
- (6) All pins, including dedicated inputs, clock, I/O, and JTAG pins, may be driven before V_{CCINT} and V_{CCIO} are powered.
- (7) Typical values are for T_A = 25° C, V_{CCINT} = 1.8 V, and V_{CCIO} = 1.8 V, 2.5 V or 3.3 V.
- (8) These values are specified under the APEX 20KE device recommended operating conditions, shown in Table 24 on page 60.
- (9) Refer to *Application Note 117 (Using Selectable I/O Standards in Altera Devices)* for the V_{IH}, V_{IL}, V_{OH}, V_{OL}, and I_I parameters when V_{CCIO} = 1.8 V.
- (10) The APEX 20KE input buffers are compatible with 1.8-V, 2.5-V and 3.3-V (LVTTTL and LVCMOS) signals. Additionally, the input buffers are 3.3-V PCI compliant. Input buffers also meet specifications for GTL+, CTT, AGP, SSTL-2, SSTL-3, and HSTL.
- (11) The I_{OH} parameter refers to high-level TTL, PCI, or CMOS output current.
- (12) The I_{OL} parameter refers to low-level TTL, PCI, or CMOS output current. This parameter applies to open-drain pins as well as output pins.
- (13) This value is specified for normal device operation. The value may vary during power-up.
- (14) Pin pull-up resistance values will be lower if an external source drives the pin higher than V_{CCIO}.
- (15) Capacitance is sample-tested only.

Figure 33 shows the relationship between V_{CCIO} and V_{CCINT} for 3.3-V PCI compliance on APEX 20K devices.

Table 46. EP20K200 External Bidirectional Timing Parameters

Symbol	-1 Speed Grade		-2 Speed Grade		-3 Speed Grade		Unit
	Min	Max	Min	Max	Min	Max	
$t_{\text{INSUBIDIR}} (1)$	1.9		2.3		2.6		ns
$t_{\text{INHBIDIR}} (1)$	0.0		0.0		0.0		ns
$t_{\text{OUTCOBIDIR}} (1)$	2.0	4.6	2.0	5.6	2.0	6.8	ns
$t_{\text{XZBIDIR}} (1)$		5.0		5.9		6.9	ns
$t_{\text{ZXBIDIR}} (1)$		5.0		5.9		6.9	ns
$t_{\text{INSUBIDIR}} (2)$	1.1		1.2		–		ns
$t_{\text{INHBIDIR}} (2)$	0.0		0.0		–		ns
$t_{\text{OUTCOBIDIR}} (2)$	0.5	2.7	0.5	3.1	–	–	ns
$t_{\text{XZBIDIR}} (2)$		4.3		5.0		–	ns
$t_{\text{ZXBIDIR}} (2)$		4.3		5.0		–	ns

Table 47. EP20K400 External Timing Parameters

Symbol	-1 Speed Grade		-2 Speed Grade		-3 Speed Grade		Unit
	Min	Max	Min	Max	Min	Max	
$t_{\text{INSU}} (1)$	1.4		1.8		2.0		ns
$t_{\text{INH}} (1)$	0.0		0.0		0.0		ns
$t_{\text{OUTCO}} (1)$	2.0	4.9	2.0	6.1	2.0	7.0	ns
$t_{\text{INSU}} (2)$	0.4		1.0		–		ns
$t_{\text{INH}} (2)$	0.0		0.0		–		ns
$t_{\text{OUTCO}} (2)$	0.5	3.1	0.5	4.1	–	–	ns

Table 48. EP20K400 External Bidirectional Timing Parameters

Symbol	-1 Speed Grade		-2 Speed Grade		-3 Speed Grade		Unit
	Min	Max	Min	Max	Min	Max	
$t_{\text{INSUBIDIR}} (1)$	1.4		1.8		2.0		ns
$t_{\text{INHBIDIR}} (1)$	0.0		0.0		0.0		ns
$t_{\text{OUTCOBIDIR}} (1)$	2.0	4.9	2.0	6.1	2.0	7.0	ns
$t_{\text{XZBIDIR}} (1)$		7.3		8.9		10.3	ns
$t_{\text{ZXBIDIR}} (1)$		7.3		8.9		10.3	ns
$t_{\text{INSUBIDIR}} (2)$	0.5		1.0		–		ns
$t_{\text{INHBIDIR}} (2)$	0.0		0.0		–		ns
$t_{\text{OUTCOBIDIR}} (2)$	0.5	3.1	0.5	4.1	–	–	ns
$t_{\text{XZBIDIR}} (2)$		6.2		7.6		–	ns
$t_{\text{ZXBIDIR}} (2)$		6.2		7.6		–	ns

Table 50. EP20K30E f_{MAX} ESB Timing Microparameters

Symbol	-1		-2		-3		Unit
	Min	Max	Min	Max	Min	Max	
t_{ESBARC}		2.03		2.86		4.24	ns
t_{ESBSRC}		2.58		3.49		5.02	ns
t_{ESBAWC}		3.88		5.45		8.08	ns
t_{ESBSWC}		4.08		5.35		7.48	ns
$t_{ESBWASU}$	1.77		2.49		3.68		ns
t_{ESBWAH}	0.00		0.00		0.00		ns
$t_{ESBWDSU}$	1.95		2.74		4.05		ns
t_{ESBWDH}	0.00		0.00		0.00		ns
$t_{ESBRASU}$	1.96		2.75		4.07		ns
t_{ESBRAH}	0.00		0.00		0.00		ns
$t_{ESBWESU}$	1.80		2.73		4.28		ns
t_{ESBWEH}	0.00		0.00		0.00		ns
$t_{ESBDATASU}$	0.07		0.48		1.17		ns
$t_{ESBDATAH}$	0.13		0.13		0.13		ns
$t_{ESBWADDRSU}$	0.30		0.80		1.64		ns
$t_{ESBRADDRSU}$	0.37		0.90		1.78		ns
$t_{ESBDATACO1}$		1.11		1.32		1.67	ns
$t_{ESBDATACO2}$		2.65		3.73		5.53	ns
t_{ESBDD}		3.88		5.45		8.08	ns
t_{PD}		1.91		2.69		3.98	ns
$t_{PTERMSU}$	1.04		1.71		2.82		ns
$t_{PTERMCO}$		1.13		1.34		1.69	ns

Table 51. EP20K30E f_{MAX} Routing Delays

Symbol	-1		-2		-3		Unit
	Min	Max	Min	Max	Min	Max	
t_{F1-4}		0.24		0.27		0.31	ns
t_{F5-20}		1.03		1.14		1.30	ns
t_{F20+}		1.42		1.54		1.77	ns

Table 52. EP20K30E Minimum Pulse Width Timing Parameters

Symbol	-1		-2		-3		Unit
	Min	Max	Min	Max	Min	Max	
t _{CH}	0.55		0.78		1.15		ns
t _{CL}	0.55		0.78		1.15		ns
t _{CLRP}	0.22		0.31		0.46		ns
t _{PREP}	0.22		0.31		0.46		ns
t _{ESBCH}	0.55		0.78		1.15		ns
t _{ESBCL}	0.55		0.78		1.15		ns
t _{ESBWP}	1.43		2.01		2.97		ns
t _{ESBRP}	1.15		1.62		2.39		ns

Table 53. EP20K30E External Timing Parameters

Symbol	-1		-2		-3		Unit
	Min	Max	Min	Max	Min	Max	
t _{INSU}	2.02		2.13		2.24		ns
t _{INH}	0.00		0.00		0.00		ns
t _{OUTCO}	2.00	4.88	2.00	5.36	2.00	5.88	ns
t _{INSUPLL}	2.11		2.23		-		ns
t _{INHPLL}	0.00		0.00		-		ns
t _{OUTCOPLL}	0.50	2.60	0.50	2.88	-	-	ns

Table 54. EP20K30E External Bidirectional Timing Parameters

Symbol	-1		-2		-3		Unit
	Min	Max	Min	Max	Min	Max	
t _{INSUBIDIR}	1.85		1.77		1.54		ns
t _{INHBIDIR}	0.00		0.00		0.00		ns
t _{OUTCOBIDIR}	2.00	4.88	2.00	5.36	2.00	5.88	ns
t _{XZBIDIR}		7.48		8.46		9.83	ns
t _{ZXBIDIR}		7.48		8.46		9.83	ns
t _{INSUBIDIRPLL}	4.12		4.24		-		ns
t _{INHBIDIRPLL}	0.00		0.00		-		ns
t _{OUTCOBIDIRPLL}	0.50	2.60	0.50	2.88	-	-	ns
t _{XZBIDIRPLL}		5.21		5.99		-	ns
t _{ZXBIDIRPLL}		5.21		5.99		-	ns

Table 57. EP20K60E f_{MAX} Routing Delays

Symbol	-1		-2		-3		Unit
	Min	Max	Min	Max	Min	Max	
t_{F1-4}		0.24		0.26		0.30	ns
t_{F5-20}		1.45		1.58		1.79	ns
t_{F20+}		1.96		2.14		2.45	ns

Table 58. EP20K60E Minimum Pulse Width Timing Parameters

Symbol	-1		-2		-3		Unit
	Min	Max	Min	Max	Min	Max	
t_{CH}	2.00		2.50		2.75		ns
t_{CL}	2.00		2.50		2.75		ns
t_{CLRP}	0.20		0.28		0.41		ns
t_{PREP}	0.20		0.28		0.41		ns
t_{ESBCH}	2.00		2.50		2.75		ns
t_{ESBCL}	2.00		2.50		2.75		ns
t_{ESBWP}	1.29		1.80		2.66		ns
t_{ESBRP}	1.04		1.45		2.14		ns

Table 59. EP20K60E External Timing Parameters

Symbol	-1		-2		-3		Unit
	Min	Max	Min	Max	Min	Max	
t_{INSU}	2.03		2.12		2.23		ns
t_{INH}	0.00		0.00		0.00		ns
t_{OUTCO}	2.00	4.84	2.00	5.31	2.00	5.81	ns
$t_{INSUPLL}$	1.12		1.15		-		ns
t_{INHPLL}	0.00		0.00		-		ns
$t_{OUTCOPLL}$	0.50	3.37	0.50	3.69	-	-	ns

Table 62. EP20K100E t_{MAX} ESB Timing Microparameters

Symbol	-1		-2		-3		Unit
	Min	Max	Min	Max	Min	Max	
t_{ESBARC}		1.61		1.84		1.97	ns
t_{ESBSRC}		2.57		2.97		3.20	ns
t_{ESBAWC}		0.52		4.09		4.39	ns
t_{ESBSWC}		3.17		3.78		4.09	ns
$t_{ESBWASU}$	0.56		6.41		0.63		ns
t_{ESBWAH}	0.48		0.54		0.55		ns
$t_{ESBWDSU}$	0.71		0.80		0.81		ns
t_{ESBWDH}	.048		0.54		0.55		ns
$t_{ESBRASU}$	1.57		1.75		1.87		ns
t_{ESBRAH}	0.00		0.00		0.20		ns
$t_{ESBWESU}$	1.54		1.72		1.80		ns
t_{ESBWEH}	0.00		0.00		0.00		ns
$t_{ESBDATASU}$	-0.16		-0.20		-0.20		ns
$t_{ESBDATAH}$	0.13		0.13		0.13		ns
$t_{ESBWADDRSU}$	0.12		0.08		0.13		ns
$t_{ESBRADDRSU}$	0.17		0.15		0.19		ns
$t_{ESBDATACO1}$		1.20		1.39		1.52	ns
$t_{ESBDATACO2}$		2.54		2.99		3.22	ns
t_{ESBDD}		3.06		3.56		3.85	ns
t_{PD}		1.73		2.02		2.20	ns
$t_{PTERMSU}$	1.11		1.26		1.38		ns
$t_{PTERMCO}$		1.19		1.40		1.08	ns

Table 63. EP20K100E t_{MAX} Routing Delays

Symbol	-1		-2		-3		Unit
	Min	Max	Min	Max	Min	Max	
t_{F1-4}		0.24		0.27		0.29	ns
t_{F5-20}		1.04		1.26		1.52	ns
t_{F20+}		1.12		1.36		1.86	ns

Table 74. EP20K200E t_{MAX} ESB Timing Microparameters

Symbol	-1		-2		-3		Unit
	Min	Max	Min	Max	Min	Max	
t_{ESBARC}		1.68		2.06		2.24	ns
t_{ESBSRC}		2.27		2.77		3.18	ns
t_{ESBAWC}		3.10		3.86		4.50	ns
t_{ESBSWC}		2.90		3.67		4.21	ns
$t_{ESBWASU}$	0.55		0.67		0.74		ns
t_{ESBWAH}	0.36		0.46		0.48		ns
$t_{ESBWDSU}$	0.69		0.83		0.95		ns
t_{ESBWDH}	0.36		0.46		0.48		ns
$t_{ESBRASU}$	1.61		1.90		2.09		ns
t_{ESBRAH}	0.00		0.00		0.01		ns
$t_{ESBWESU}$	1.42		1.71		2.01		ns
t_{ESBWEH}	0.00		0.00		0.00		ns
$t_{ESBDATASU}$	-0.06		-0.07		0.05		ns
$t_{ESBDATAH}$	0.13		0.13		0.13		ns
$t_{ESBWADDRSU}$	0.11		0.13		0.31		ns
$t_{ESBRADDRSU}$	0.18		0.23		0.39		ns
$t_{ESBDATACO1}$		1.09		1.35		1.51	ns
$t_{ESBDATACO2}$		2.19		2.75		3.22	ns
t_{ESBDD}		2.75		3.41		4.03	ns
t_{PD}		1.58		1.97		2.33	ns
$t_{PTERMSU}$	1.00		1.22		1.51		ns
$t_{PTERMCO}$		1.10		1.37		1.09	ns

Table 75. EP20K200E t_{MAX} Routing Delays

Symbol	-1		-2		-3		Unit
	Min	Max	Min	Max	Min	Max	
t_{F1-4}		0.25		0.27		0.29	ns
t_{F5-20}		1.02		1.20		1.41	ns
t_{F20+}		1.99		2.23		2.53	ns

Table 76. EP20K200E Minimum Pulse Width Timing Parameters

Symbol	-1		-2		-3		Unit
	Min	Max	Min	Max	Min	Max	
t _{CH}	1.36		2.44		2.65		ns
t _{CL}	1.36		2.44		2.65		ns
t _{CLRP}	0.18		0.19		0.21		ns
t _{PREP}	0.18		0.19		0.21		ns
t _{ESBCH}	1.36		2.44		2.65		ns
t _{ESBCL}	1.36		2.44		2.65		ns
t _{ESBWP}	1.18		1.48		1.76		ns
t _{ESBRP}	0.95		1.17		1.41		ns

Table 77. EP20K200E External Timing Parameters

Symbol	-1		-2		-3		Unit
	Min	Max	Min	Max	Min	Max	
t _{INSU}	2.24		2.35		2.47		ns
t _{INH}	0.00		0.00		0.00		ns
t _{OUTCO}	2.00	5.12	2.00	5.62	2.00	6.11	ns
t _{INSUPLL}	2.13		2.07		-		ns
t _{INHPLL}	0.00		0.00		-		ns
t _{OUTCOPLL}	0.50	3.01	0.50	3.36	-	-	ns