

Welcome to E-XFL.COM

Understanding Embedded - FPGAs (Field Programmable Gate Array)

Embedded - FPGAs, or Field Programmable Gate Arrays, are advanced integrated circuits that offer unparalleled flexibility and performance for digital systems. Unlike traditional fixed-function logic devices, FPGAs can be programmed and reprogrammed to execute a wide array of logical operations, enabling customized functionality tailored to specific applications. This reprogrammability allows developers to iterate designs quickly and implement complex functions without the need for custom hardware.

Applications of Embedded - FPGAs

The versatility of Embedded - FPGAs makes them indispensable in numerous fields. In telecommunications.

Details

Product Status	Active
Number of LABs/CLBs	640
Number of Logic Elements/Cells	-
Total RAM Bits	-
Number of I/O	316
Number of Gates	-
Voltage - Supply	1.71V ~ 1.89V
Mounting Type	Surface Mount
Operating Temperature	0°C ~ 85°C (TJ)
Package / Case	484-BBGA
Supplier Device Package	484-FBGA (23x23)
Purchase URL	https://www.e-xfl.com/pro/item?MUrl=&PartUrl=ep20k160efc484-2x

- Flexible clock management circuitry with up to four phase-locked loops (PLLs)
 - Built-in low-skew clock tree
 - Up to eight global clock signals
 - ClockLock[®] feature reducing clock delay and skew
 - ClockBoost[®] feature providing clock multiplication and division
 - ClockShift[™] programmable clock phase and delay shifting
- Powerful I/O features
 - Compliant with peripheral component interconnect Special Interest Group (PCI SIG) *PCI Local Bus Specification, Revision 2.2* for 3.3-V operation at 33 or 66 MHz and 32 or 64 bits
 - Support for high-speed external memories, including DDR SDRAM and ZBT SRAM (ZBT is a trademark of Integrated Device Technology, Inc.)
 - Bidirectional I/O performance ($t_{CO} + t_{SU}$) up to 250 MHz
 - LVDS performance up to 840 Mbits per channel
 - Direct connection from I/O pins to local interconnect providing fast t_{CO} and t_{SU} times for complex logic
 - MultiVolt I/O interface support to interface with 1.8-V, 2.5-V, 3.3-V, and 5.0-V devices (see [Table 3](#))
 - Programmable clamp to V_{CCIO}
 - Individual tri-state output enable control for each pin
 - Programmable output slew-rate control to reduce switching noise
 - Support for advanced I/O standards, including low-voltage differential signaling (LVDS), LVPECL, PCI-X, AGP, CTT, stub-series terminated logic (SSTL-3 and SSTL-2), Gunning transceiver logic plus (GTL+), and high-speed terminated logic (HSTL Class I)
 - Pull-up on I/O pins before and during configuration
- Advanced interconnect structure
 - Four-level hierarchical FastTrack[®] Interconnect structure providing fast, predictable interconnect delays
 - Dedicated carry chain that implements arithmetic functions such as fast adders, counters, and comparators (automatically used by software tools and megafunctions)
 - Dedicated cascade chain that implements high-speed, high-fan-in logic functions (automatically used by software tools and megafunctions)
 - Interleaved local interconnect allows one LE to drive 29 other LEs through the fast local interconnect
- Advanced packaging options
 - Available in a variety of packages with 144 to 1,020 pins (see [Tables 4 through 7](#))
 - FineLine BGA[®] packages maximize board space efficiency
- Advanced software support
 - Software design support and automatic place-and-route provided by the Altera[®] Quartus[®] II development system for

Windows-based PCs, Sun SPARCstations, and HP 9000 Series 700/800 workstations

- Altera MegaCore® functions and Altera Megafunction Partners Program (AMPPSM) megafunctions
- NativeLink™ integration with popular synthesis, simulation, and timing analysis tools
- Quartus II SignalTap® embedded logic analyzer simplifies in-system design evaluation by giving access to internal nodes during device operation
- Supports popular revision-control software packages including PVCS, Revision Control System (RCS), and Source Code Control System (SCCS)

Table 4. APEX 20K QFP, BGA & PGA Package Options & I/O Count *Notes (1), (2)*

Device	144-Pin TQFP	208-Pin PQFP RQFP	240-Pin PQFP RQFP	356-Pin BGA	652-Pin BGA	655-Pin PGA
EP20K30E	92	125				
EP20K60E	92	148	151	196		
EP20K100	101	159	189	252		
EP20K100E	92	151	183	246		
EP20K160E	88	143	175	271		
EP20K200		144	174	277		
EP20K200E		136	168	271	376	
EP20K300E			152		408	
EP20K400					502	502
EP20K400E					488	
EP20K600E					488	
EP20K1000E					488	
EP20K1500E					488	

All APEX 20K devices are reconfigurable and are 100% tested prior to shipment. As a result, test vectors do not have to be generated for fault coverage purposes. Instead, the designer can focus on simulation and design verification. In addition, the designer does not need to manage inventories of different application-specific integrated circuit (ASIC) designs; APEX 20K devices can be configured on the board for the specific functionality required.

APEX 20K devices are configured at system power-up with data stored in an Altera serial configuration device or provided by a system controller. Altera offers in-system programmability (ISP)-capable EPC1, EPC2, and EPC16 configuration devices, which configure APEX 20K devices via a serial data stream. Moreover, APEX 20K devices contain an optimized interface that permits microprocessors to configure APEX 20K devices serially or in parallel, and synchronously or asynchronously. The interface also enables microprocessors to treat APEX 20K devices as memory and configure the device by writing to a virtual memory location, making reconfiguration easy.

After an APEX 20K device has been configured, it can be reconfigured in-circuit by resetting the device and loading new data. Real-time changes can be made during system operation, enabling innovative reconfigurable computing applications.

APEX 20K devices are supported by the Altera Quartus II development system, a single, integrated package that offers HDL and schematic design entry, compilation and logic synthesis, full simulation and worst-case timing analysis, SignalTap logic analysis, and device configuration. The Quartus II software runs on Windows-based PCs, Sun SPARCstations, and HP 9000 Series 700/800 workstations.

The Quartus II software provides NativeLink interfaces to other industry-standard PC- and UNIX workstation-based EDA tools. For example, designers can invoke the Quartus II software from within third-party design tools. Further, the Quartus II software contains built-in optimized synthesis libraries; synthesis tools can use these libraries to optimize designs for APEX 20K devices. For example, the Synopsys Design Compiler library, supplied with the Quartus II development system, includes DesignWare functions optimized for the APEX 20K architecture.

Each LAB contains dedicated logic for driving control signals to its LEs and ESBs. The control signals include clock, clock enable, asynchronous clear, asynchronous preset, asynchronous load, synchronous clear, and synchronous load signals. A maximum of six control signals can be used at a time. Although synchronous load and clear signals are generally used when implementing counters, they can also be used with other functions.

Each LAB can use two clocks and two clock enable signals. Each LAB's clock and clock enable signals are linked (e.g., any LE in a particular LAB using CLK1 will also use CLKENA1). LEs with the same clock but different clock enable signals either use both clock signals in one LAB or are placed into separate LABs.

If both the rising and falling edges of a clock are used in a LAB, both LAB-wide clock signals are used.

The LAB-wide control signals can be generated from the LAB local interconnect, global signals, and dedicated clock pins. The inherent low skew of the FastTrack Interconnect enables it to be used for clock distribution. **Figure 4** shows the LAB control signal generation circuit.

Figure 4. LAB Control Signal Generation

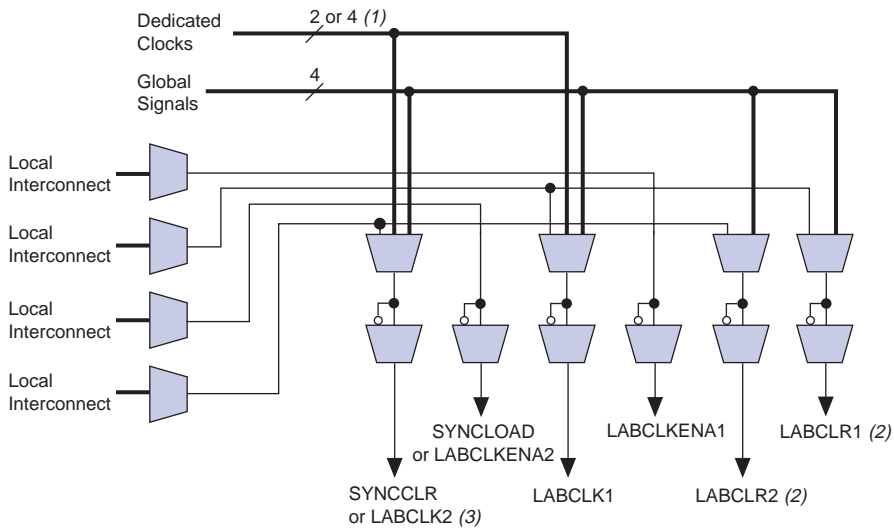

Notes to Figure 4:

- (1) APEX 20KE devices have four dedicated clocks.
- (2) The LABCLR1 and LABCLR2 signals also control asynchronous load and asynchronous preset for LEs within the LAB.
- (3) The SYNCCLR signal can be generated by the local interconnect or global signals.

LE Operating Modes

The APEX 20K LE can operate in one of the following three modes:

- Normal mode
- Arithmetic mode
- Counter mode

Each mode uses LE resources differently. In each mode, seven available inputs to the LE—the four data inputs from the LAB local interconnect, the feedback from the programmable register, and the carry-in and cascade-in from the previous LE—are directed to different destinations to implement the desired logic function. LAB-wide signals provide clock, asynchronous clear, asynchronous preset, asynchronous load, synchronous clear, synchronous load, and clock enable control for the register. These LAB-wide signals are available in all LE modes.

The Quartus II software, in conjunction with parameterized functions such as LPM and DesignWare functions, automatically chooses the appropriate mode for common functions such as counters, adders, and multipliers. If required, the designer can also create special-purpose functions that specify which LE operating mode to use for optimal performance. [Figure 8](#) shows the LE operating modes.

Figure 9. APEX 20K Interconnect Structure

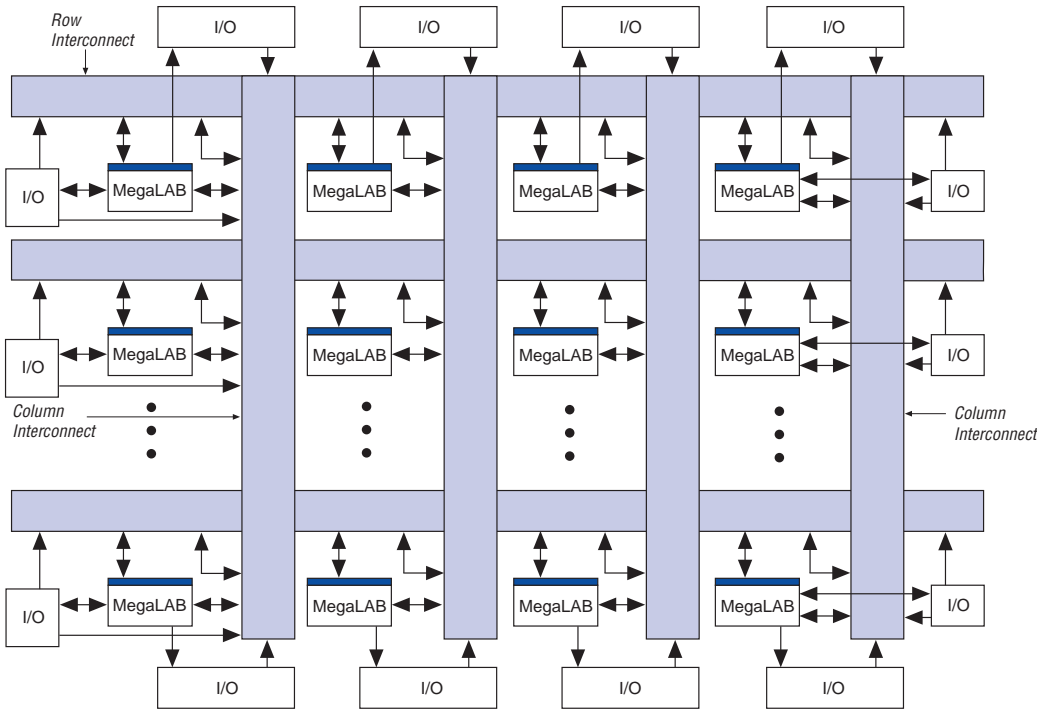

A row line can be driven directly by LEs, IOEs, or ESBs in that row. Further, a column line can drive a row line, allowing an LE, IOE, or ESB to drive elements in a different row via the column and row interconnect. The row interconnect drives the MegaLAB interconnect to drive LEs, IOEs, or ESBs in a particular MegaLAB structure.

A column line can be directly driven by LEs, IOEs, or ESBs in that column. A column line on a device's left or right edge can also be driven by row IOEs. The column line is used to route signals from one row to another. A column line can drive a row line; it can also drive the MegaLAB interconnect directly, allowing faster connections between rows.

Figure 10 shows how the FastTrack Interconnect uses the local interconnect to drive LEs within MegaLAB structures.

Input/Output Clock Mode

The input/output clock mode contains two clocks. One clock controls all registers for inputs into the ESB: data input, WE, RE, read address, and write address. The other clock controls the ESB data output registers. The ESB also supports clock enable and asynchronous clear signals; these signals also control the reading and writing of registers independently. Input/output clock mode is commonly used for applications where the reads and writes occur at the same system frequency, but require different clock enable signals for the input and output registers. Figure 21 shows the ESB in input/output clock mode.

Figure 21. ESB in Input/Output Clock Mode Note (1)

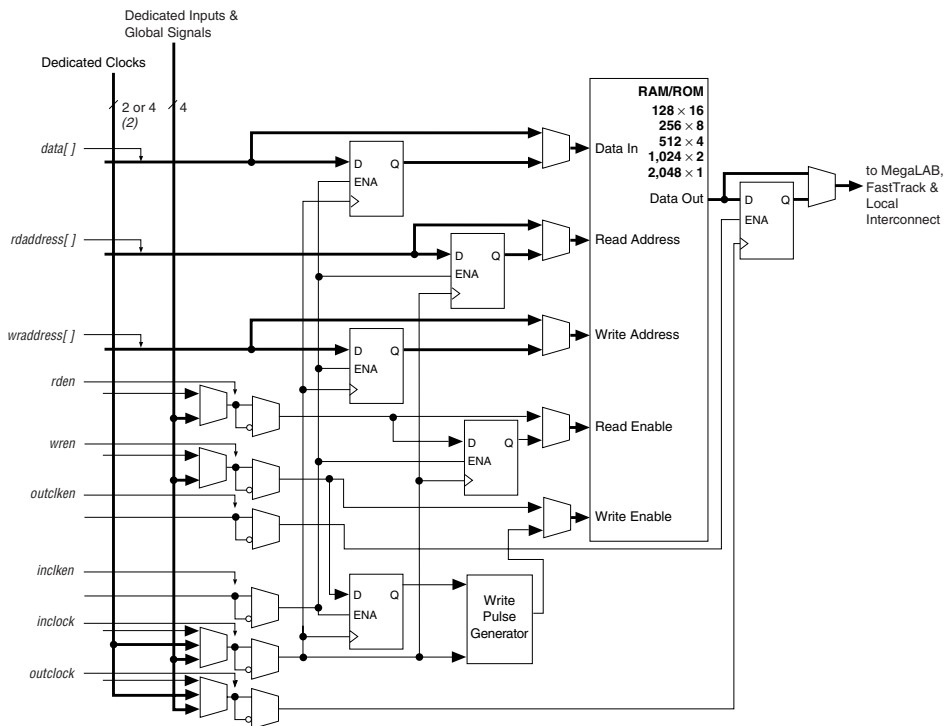

Notes to Figure 21:

- (1) All registers can be cleared asynchronously by ESB local interconnect signals, global signals, or the chip-wide reset.
- (2) APEX 20KE devices have four dedicated clocks.

Single-Port Mode

The APEX 20K ESB also supports a single-port mode, which is used when simultaneous reads and writes are not required. See Figure 22.



For more information on APEX 20KE devices and CAM, see *Application Note 119 (Implementing High-Speed Search Applications with APEX CAM)*.

Driving Signals to the ESB

ESBs provide flexible options for driving control signals. Different clocks can be used for the ESB inputs and outputs. Registers can be inserted independently on the data input, data output, read address, write address, WE, and RE signals. The global signals and the local interconnect can drive the WE and RE signals. The global signals, dedicated clock pins, and local interconnect can drive the ESB clock signals. Because the LEs drive the local interconnect, the LEs can control the WE and RE signals and the ESB clock, clock enable, and asynchronous clear signals. [Figure 24](#) shows the ESB control signal generation logic.

Figure 24. ESB Control Signal Generation

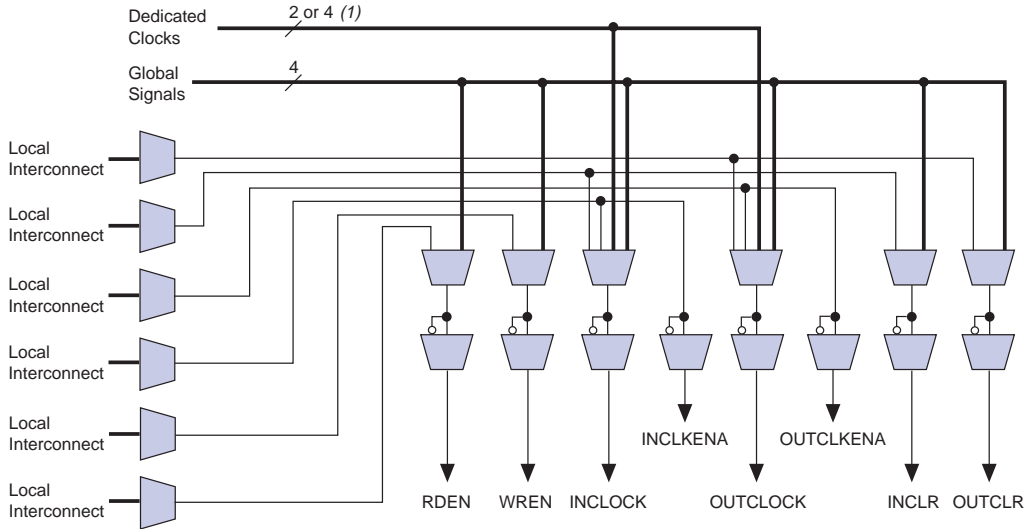

Note to Figure 24:

(1) APEX 20KE devices have four dedicated clocks.

An ESB is fed by the local interconnect, which is driven by adjacent LEs (for high-speed connection to the ESB) or the MegaLAB interconnect. The ESB can drive the local, MegaLAB, or FastTrack Interconnect routing structure to drive LEs and IOEs in the same MegaLAB structure or anywhere in the device.

Implementing Logic in ROM

In addition to implementing logic with product terms, the ESB can implement logic functions when it is programmed with a read-only pattern during configuration, creating a large LUT. With LUTs, combinatorial functions are implemented by looking up the results, rather than by computing them. This implementation of combinatorial functions can be faster than using algorithms implemented in general logic, a performance advantage that is further enhanced by the fast access times of ESBs. The large capacity of ESBs enables designers to implement complex functions in one logic level without the routing delays associated with linked LEs or distributed RAM blocks. Parameterized functions such as LPM functions can take advantage of the ESB automatically. Further, the Quartus II software can implement portions of a design with ESBs where appropriate.

Programmable Speed/Power Control

APEX 20K ESBs offer a high-speed mode that supports very fast operation on an ESB-by-ESB basis. When high speed is not required, this feature can be turned off to reduce the ESB's power dissipation by up to 50%. ESBs that run at low power incur a nominal timing delay adder. This Turbo Bit™ option is available for ESBs that implement product-term logic or memory functions. An ESB that is not used will be powered down so that it does not consume DC current.

Designers can program each ESB in the APEX 20K device for either high-speed or low-power operation. As a result, speed-critical paths in the design can run at high speed, while the remaining paths operate at reduced power.

I/O Structure

The APEX 20K IOE contains a bidirectional I/O buffer and a register that can be used either as an input register for external data requiring fast setup times, or as an output register for data requiring fast clock-to-output performance. IOEs can be used as input, output, or bidirectional pins. For fast bidirectional I/O timing, LE registers using local routing can improve setup times and OE timing. The Quartus II software Compiler uses the programmable inversion option to invert signals from the row and column interconnect automatically where appropriate. Because the APEX 20K IOE offers one output enable per pin, the Quartus II software Compiler can emulate open-drain operation efficiently.

The APEX 20K IOE includes programmable delays that can be activated to ensure zero hold times, minimum clock-to-output times, input IOE register-to-core register transfers, or core-to-output IOE register transfers. A path in which a pin directly drives a register may require the delay to ensure zero hold time, whereas a path in which a pin drives a register through combinatorial logic may not require the delay.

Clock Phase & Delay Adjustment

The APEX 20KE ClockShift feature allows the clock phase and delay to be adjusted. The clock phase can be adjusted by 90° steps. The clock delay can be adjusted to increase or decrease the clock delay by an arbitrary amount, up to one clock period.

LVDS Support

Two PLLs are designed to support the LVDS interface. When using LVDS, the I/O clock runs at a slower rate than the data transfer rate. Thus, PLLs are used to multiply the I/O clock internally to capture the LVDS data. For example, an I/O clock may run at 105 MHz to support 840 megabits per second (Mbps) LVDS data transfer. In this example, the PLL multiplies the incoming clock by eight to support the high-speed data transfer. You can use PLLs in EP20K400E and larger devices for high-speed LVDS interfacing.

Lock Signals

The APEX 20KE ClockLock circuitry supports individual LOCK signals. The LOCK signal drives high when the ClockLock circuit has locked onto the input clock. The LOCK signals are optional for each ClockLock circuit; when not used, they are I/O pins.

ClockLock & ClockBoost Timing Parameters

For the ClockLock and ClockBoost circuitry to function properly, the incoming clock must meet certain requirements. If these specifications are not met, the circuitry may not lock onto the incoming clock, which generates an erroneous clock within the device. The clock generated by the ClockLock and ClockBoost circuitry must also meet certain specifications. If the incoming clock meets these requirements during configuration, the APEX 20K ClockLock and ClockBoost circuitry will lock onto the clock during configuration. The circuit will be ready for use immediately after configuration. In APEX 20KE devices, the clock input standard is programmable, so the PLL cannot respond to the clock until the device is configured. The PLL locks onto the input clock as soon as configuration is complete. [Figure 30](#) shows the incoming and generated clock specifications.



For more information on ClockLock and ClockBoost circuitry, see *Application Note 115: Using the ClockLock and ClockBoost PLL Features in APEX Devices*.

IEEE Std. 1149.1 (JTAG) Boundary-Scan Support

All APEX 20K devices provide JTAG BST circuitry that complies with the IEEE Std. 1149.1-1990 specification. JTAG boundary-scan testing can be performed before or after configuration, but not during configuration. APEX 20K devices can also use the JTAG port for configuration with the Quartus II software or with hardware using either Jam Files (.jam) or Jam Byte-Code Files (.jbc). Finally, APEX 20K devices use the JTAG port to monitor the logic operation of the device with the SignalTap embedded logic analyzer. APEX 20K devices support the JTAG instructions shown in Table 19. Although EP20K1500E devices support the JTAG BYPASS and SignalTap instructions, they do not support boundary-scan testing or the use of the JTAG port for configuration.

Table 19. APEX 20K JTAG Instructions

JTAG Instruction	Description
SAMPLE/PRELOAD	Allows a snapshot of signals at the device pins to be captured and examined during normal device operation, and permits an initial data pattern to be output at the device pins. Also used by the SignalTap embedded logic analyzer.
EXTEST	Allows the external circuitry and board-level interconnections to be tested by forcing a test pattern at the output pins and capturing test results at the input pins.
BYPASS (1)	Places the 1-bit bypass register between the TDI and TDO pins, which allows the BST data to pass synchronously through selected devices to adjacent devices during normal device operation.
USERCODE	Selects the 32-bit USERCODE register and places it between the TDI and TDO pins, allowing the USERCODE to be serially shifted out of TDO.
IDCODE	Selects the IDCODE register and places it between TDI and TDO, allowing the IDCODE to be serially shifted out of TDO.
ICR Instructions	Used when configuring an APEX 20K device via the JTAG port with a MasterBlaster™ or ByteBlasterMV™ download cable, or when using a Jam File or Jam Byte-Code File via an embedded processor.
SignalTap Instructions (1)	Monitors internal device operation with the SignalTap embedded logic analyzer.

Note to Table 19:

(1) The EP20K1500E device supports the JTAG BYPASS instruction and the SignalTap instructions.

Table 26. APEX 20K 5.0-V Tolerant Device Capacitance Notes (2), (14)

Symbol	Parameter	Conditions	Min	Max	Unit
C _{IN}	Input capacitance	V _{IN} = 0 V, f = 1.0 MHz		8	pF
C _{INCLK}	Input capacitance on dedicated clock pin	V _{IN} = 0 V, f = 1.0 MHz		12	pF
C _{OUT}	Output capacitance	V _{OUT} = 0 V, f = 1.0 MHz		8	pF

Notes to Tables 23 through 26:

- (1) See the *Operating Requirements for Altera Devices Data Sheet*.
- (2) All APEX 20K devices are 5.0-V tolerant.
- (3) Minimum DC input is -0.5 V. During transitions, the inputs may undershoot to -2.0 V or overshoot to 5.75 V for input currents less than 100 mA and periods shorter than 20 ns.
- (4) Numbers in parentheses are for industrial-temperature-range devices.
- (5) Maximum V_{CC} rise time is 100 ms, and V_{CC} must rise monotonically.
- (6) All pins, including dedicated inputs, clock I/O, and JTAG pins, may be driven before V_{CCINT} and V_{CCIO} are powered.
- (7) Typical values are for T_A = 25° C, V_{CCINT} = 2.5 V, and V_{CCIO} = 2.5 or 3.3 V.
- (8) These values are specified in the APEX 20K device recommended operating conditions, shown in Table 26 on page 62.
- (9) The APEX 20K input buffers are compatible with 2.5-V and 3.3-V (LVTTTL and LVCMOS) signals. Additionally, the input buffers are 3.3-V PCI compliant when V_{CCIO} and V_{CCINT} meet the relationship shown in Figure 33 on page 68.
- (10) The I_{OH} parameter refers to high-level TTL, PCI or CMOS output current.
- (11) The I_{OL} parameter refers to low-level TTL, PCI, or CMOS output current. This parameter applies to open-drain pins as well as output pins.
- (12) This value is specified for normal device operation. The value may vary during power-up.
- (13) Pin pull-up resistance values will be lower if an external source drives the pin higher than V_{CCIO}.
- (14) Capacitance is sample-tested only.

Tables 27 through 30 provide information on absolute maximum ratings, recommended operating conditions, DC operating conditions, and capacitance for 1.8-V APEX 20KE devices.

Table 27. APEX 20KE Device Absolute Maximum Ratings Note (1)

Symbol	Parameter	Conditions	Min	Max	Unit
V _{CCINT}	Supply voltage	With respect to ground (2)	-0.5	2.5	V
V _{CCIO}			-0.5	4.6	V
V _I			-0.5	4.6	V
I _{OUT}	DC output current, per pin		-25	25	mA
T _{STG}	Storage temperature	No bias	-65	150	° C
T _{AMB}	Ambient temperature	Under bias	-65	135	° C
T _J	Junction temperature	PQFP, RQFP, TQFP, and BGA packages, under bias		135	° C
		Ceramic PGA packages, under bias		150	° C



For DC Operating Specifications on APEX 20KE I/O standards, please refer to *Application Note 117 (Using Selectable I/O Standards in Altera Devices)*.

Table 30. APEX 20KE Device Capacitance Note (15)

Symbol	Parameter	Conditions	Min	Max	Unit
C _{IN}	Input capacitance	V _{IN} = 0 V, f = 1.0 MHz		8	pF
C _{INCLK}	Input capacitance on dedicated clock pin	V _{IN} = 0 V, f = 1.0 MHz		12	pF
C _{OUT}	Output capacitance	V _{OUT} = 0 V, f = 1.0 MHz		8	pF

Notes to Tables 27 through 30:

- (1) See the *Operating Requirements for Altera Devices Data Sheet*.
- (2) Minimum DC input is -0.5 V. During transitions, the inputs may undershoot to -2.0 V or overshoot to 5.75 V for input currents less than 100 mA and periods shorter than 20 ns.
- (3) Numbers in parentheses are for industrial-temperature-range devices.
- (4) Maximum V_{CC} rise time is 100 ms, and V_{CC} must rise monotonically.
- (5) Minimum DC input is -0.5 V. During transitions, the inputs may undershoot to -2.0 V or overshoot to the voltage shown in the following table based on input duty cycle for input currents less than 100 mA. The overshoot is dependent upon duty cycle of the signal. The DC case is equivalent to 100% duty cycle.

V _{in}	Max. Duty Cycle
4.0V	100% (DC)
4.1	90%
4.2	50%
4.3	30%
4.4	17%
4.5	10%
- (6) All pins, including dedicated inputs, clock, I/O, and JTAG pins, may be driven before V_{CCINT} and V_{CCIO} are powered.
- (7) Typical values are for T_A = 25° C, V_{CCINT} = 1.8 V, and V_{CCIO} = 1.8 V, 2.5 V or 3.3 V.
- (8) These values are specified under the APEX 20KE device recommended operating conditions, shown in Table 24 on page 60.
- (9) Refer to *Application Note 117 (Using Selectable I/O Standards in Altera Devices)* for the V_{IH}, V_{IL}, V_{OH}, V_{OL}, and I_I parameters when V_{CCIO} = 1.8 V.
- (10) The APEX 20KE input buffers are compatible with 1.8-V, 2.5-V and 3.3-V (LVTTTL and LVCMOS) signals. Additionally, the input buffers are 3.3-V PCI compliant. Input buffers also meet specifications for GTL+, CTT, AGP, SSTL-2, SSTL-3, and HSTL.
- (11) The I_{OH} parameter refers to high-level TTL, PCI, or CMOS output current.
- (12) The I_{OL} parameter refers to low-level TTL, PCI, or CMOS output current. This parameter applies to open-drain pins as well as output pins.
- (13) This value is specified for normal device operation. The value may vary during power-up.
- (14) Pin pull-up resistance values will be lower if an external source drives the pin higher than V_{CCIO}.
- (15) Capacitance is sample-tested only.

Figure 33 shows the relationship between V_{CCIO} and V_{CCINT} for 3.3-V PCI compliance on APEX 20K devices.

Tables 40 through 42 show the f_{MAX} timing parameters for EP20K100, EP20K200, and EP20K400 APEX 20K devices.

Table 40. EP20K100 t_{MAX} Timing Parameters

Symbol	-1 Speed Grade		-2 Speed Grade		-3 Speed Grade		Units
	Min	Max	Min	Max	Min	Max	
t_{SU}	0.5		0.6		0.8		ns
t_H	0.7		0.8		1.0		ns
t_{CO}		0.3		0.4		0.5	ns
t_{LUT}		0.8		1.0		1.3	ns
t_{ESBRC}		1.7		2.1		2.4	ns
t_{ESBWC}		5.7		6.9		8.1	ns
$t_{ESBWESU}$	3.3		3.9		4.6		ns
$t_{ESBDATASU}$	2.2		2.7		3.1		ns
$t_{ESBDATAH}$	0.6		0.8		0.9		ns
$t_{ESBADDRSU}$	2.4		2.9		3.3		ns
$t_{ESBDATAO1}$		1.3		1.6		1.8	ns
$t_{ESBDATAO2}$		2.6		3.1		3.6	ns
t_{ESBDD}		2.5		3.3		3.6	ns
t_{PD}		2.5		3.0		3.6	ns
$t_{PTERMSU}$	2.3		2.6		3.2		ns
$t_{PTERMCO}$		1.5		1.8		2.1	ns
t_{F1-4}		0.5		0.6		0.7	ns
t_{F5-20}		1.6		1.7		1.8	ns
t_{F20+}		2.2		2.2		2.3	ns
t_{CH}	2.0		2.5		3.0		ns
t_{CL}	2.0		2.5		3.0		ns
t_{CLRP}	0.3		0.4		0.4		ns
t_{PREP}	0.5		0.5		0.5		ns
t_{ESBCH}	2.0		2.5		3.0		ns
t_{ESBCL}	2.0		2.5		3.0		ns
t_{ESBWP}	1.6		1.9		2.2		ns
t_{ESBRP}	1.0		1.3		1.4		ns

Table 57. EP20K60E f_{MAX} Routing Delays

Symbol	-1		-2		-3		Unit
	Min	Max	Min	Max	Min	Max	
t_{F1-4}		0.24		0.26		0.30	ns
t_{F5-20}		1.45		1.58		1.79	ns
t_{F20+}		1.96		2.14		2.45	ns

Table 58. EP20K60E Minimum Pulse Width Timing Parameters

Symbol	-1		-2		-3		Unit
	Min	Max	Min	Max	Min	Max	
t_{CH}	2.00		2.50		2.75		ns
t_{CL}	2.00		2.50		2.75		ns
t_{CLRP}	0.20		0.28		0.41		ns
t_{PREP}	0.20		0.28		0.41		ns
t_{ESBCH}	2.00		2.50		2.75		ns
t_{ESBCL}	2.00		2.50		2.75		ns
t_{ESBWP}	1.29		1.80		2.66		ns
t_{ESBRP}	1.04		1.45		2.14		ns

Table 59. EP20K60E External Timing Parameters

Symbol	-1		-2		-3		Unit
	Min	Max	Min	Max	Min	Max	
t_{INSU}	2.03		2.12		2.23		ns
t_{INH}	0.00		0.00		0.00		ns
t_{OUTCO}	2.00	4.84	2.00	5.31	2.00	5.81	ns
$t_{INSUPLL}$	1.12		1.15		-		ns
t_{INHPLL}	0.00		0.00		-		ns
$t_{OUTCOPLL}$	0.50	3.37	0.50	3.69	-	-	ns

Tables 85 through 90 describe f_{MAX} LE Timing Microparameters, f_{MAX} ESB Timing Microparameters, f_{MAX} Routing Delays, Minimum Pulse Width Timing Parameters, External Timing Parameters, and External Bidirectional Timing Parameters for EP20K400E APEX 20KE devices.

Table 85. EP20K400E f_{MAX} LE Timing Microparameters							
Symbol	-1 Speed Grade		-2 Speed Grade		-3 Speed Grade		Unit
	Min	Max	Min	Max	Min	Max	
t_{SU}	0.23		0.23		0.23		ns
t_H	0.23		0.23		0.23		ns
t_{CO}		0.25		0.29		0.32	ns
t_{LUT}		0.70		0.83		1.01	ns

Table 86. EP20K400E t_{MAX} ESB Timing Microparameters

Symbol	-1 Speed Grade		-2 Speed Grade		-3 Speed Grade		Unit
	Min	Max	Min	Max	Min	Max	
t_{ESBARC}		1.67		1.91		1.99	ns
t_{ESBSRC}		2.30		2.66		2.93	ns
t_{ESBAWC}		3.09		3.58		3.99	ns
t_{ESBSWC}		3.01		3.65		4.05	ns
$t_{ESBWASU}$	0.54		0.63		0.65		ns
t_{ESBWAH}	0.36		0.43		0.42		ns
$t_{ESBWDSU}$	0.69		0.77		0.84		ns
t_{ESBWDH}	0.36		0.43		0.42		ns
$t_{ESBRASU}$	1.61		1.77		1.86		ns
t_{ESBRAH}	0.00		0.00		0.01		ns
$t_{ESBWESU}$	1.35		1.47		1.61		ns
t_{ESBWEH}	0.00		0.00		0.00		ns
$t_{ESBDATASU}$	-0.18		-0.30		-0.27		ns
$t_{ESBDATAH}$	0.13		0.13		0.13		ns
$t_{ESBWADDRSU}$	-0.02		-0.11		-0.03		ns
$t_{ESBRADDRSU}$	0.06		-0.01		-0.05		ns
$t_{ESBDATACO1}$		1.16		1.40		1.54	ns
$t_{ESBDATACO2}$		2.18		2.55		2.85	ns
t_{ESBDD}		2.73		3.17		3.58	ns
t_{PD}		1.57		1.83		2.07	ns
$t_{PTERMSU}$	0.92		0.99		1.18		ns
$t_{PTERMCO}$		1.18		1.43		1.17	ns

Table 108. EP20K1500E External Bidirectional Timing Parameters

Symbol	-1 Speed Grade		-2 Speed Grade		-3 Speed Grade		Unit
	Min	Max	Min	Max	Min	Max	
t _{INSUBIDIR}	3.47		3.68		3.99		ns
t _{INHBDIR}	0.00		0.00		0.00		ns
t _{OUTCOBIDIR}	2.00	6.18	2.00	6.81	2.00	7.36	ns
t _{XZBIDIR}		6.91		7.62		8.38	ns
t _{ZXBIDIR}		6.91		7.62		8.38	ns
t _{INSUBIDIRPLL}	3.05		3.26				ns
t _{INHBDIRPLL}	0.00		0.00				ns
t _{OUTCOBIDIRPLL}	0.50	2.67	0.50	2.99			ns
t _{XZBIDIRPLL}		3.41		3.80			ns
t _{ZXBIDIRPLL}		3.41		3.80			ns

Tables 109 and 110 show selectable I/O standard input and output delays for APEX 20KE devices. If you select an I/O standard input or output delay other than LVCMOS, add or subtract the selected speed grade to or from the LVCMOS value.

Table 109. Selectable I/O Standard Input Delays

Symbol	-1 Speed Grade		-2 Speed Grade		-3 Speed Grade		Unit
	Min	Max	Min	Max	Min	Max	Min
LVCMOS		0.00		0.00		0.00	ns
LVTTTL		0.00		0.00		0.00	ns
2.5 V		0.00		0.04		0.05	ns
1.8 V		-0.11		0.03		0.04	ns
PCI		0.01		0.09		0.10	ns
GTL+		-0.24		-0.23		-0.19	ns
SSTL-3 Class I		-0.32		-0.21		-0.47	ns
SSTL-3 Class II		-0.08		0.03		-0.23	ns
SSTL-2 Class I		-0.17		-0.06		-0.32	ns
SSTL-2 Class II		-0.16		-0.05		-0.31	ns
LVDS		-0.12		-0.12		-0.12	ns
CTT		0.00		0.00		0.00	ns
AGP		0.00		0.00		0.00	ns

Version 4.1

APEX 20K Programmable Logic Device Family Data Sheet version 4.1 contains the following changes:

- t_{ESBWEH} added to [Figure 37](#) and [Tables 35, 50, 56, 62, 68, 74, 86, 92, 97, and 104](#).
- Updated EP20K300E device internal and external timing numbers in [Tables 79 through 84](#).



101 Innovation Drive
San Jose, CA 95134
(408) 544-7000
<http://www.altera.com>
Applications Hotline:
(800) 800-EPLD
Customer Marketing:
(408) 544-7104
Literature Services:
lit_req@altera.com

Copyright © 2004 Altera Corporation. All rights reserved. Altera, The Programmable Solutions Company, the stylized Altera logo, specific device designations, and all other words and logos that are identified as trademarks and/or service marks are, unless noted otherwise, the trademarks and service marks of Altera Corporation in the U.S. and other countries. All other product or service names are the property of their respective holders. Altera products are protected under numerous U.S. and foreign patents and pending applications, mask work rights, and copyrights. Altera warrants performance of its semiconductor products to current specifications in accordance with Altera's standard warranty, but reserves the right to make changes to any products and services at any time without notice. Altera assumes no responsibility or liability arising out of the application or use of any information, product, or service described herein except as expressly agreed to in writing by Altera Corporation. Altera customers are advised to obtain the latest version of device specifications before relying on any published information and before placing orders for products or services.



I.S. EN ISO 9001