

Welcome to [E-XFL.COM](https://www.e-xfl.com)

Understanding Embedded - FPGAs (Field Programmable Gate Array)

Embedded - FPGAs, or Field Programmable Gate Arrays, are advanced integrated circuits that offer unparalleled flexibility and performance for digital systems. Unlike traditional fixed-function logic devices, FPGAs can be programmed and reprogrammed to execute a wide array of logical operations, enabling customized functionality tailored to specific applications. This reprogrammability allows developers to iterate designs quickly and implement complex functions without the need for custom hardware.

Applications of Embedded - FPGAs

The versatility of Embedded - FPGAs makes them indispensable in numerous fields. In telecommunications.

Details

Product Status	Obsolete
Number of LABs/CLBs	832
Number of Logic Elements/Cells	8320
Total RAM Bits	106496
Number of I/O	144
Number of Gates	526000
Voltage - Supply	2.375V ~ 2.625V
Mounting Type	Surface Mount
Operating Temperature	0°C ~ 85°C (TJ)
Package / Case	208-BFQFP Exposed Pad
Supplier Device Package	208-RQFP (28x28)
Purchase URL	https://www.e-xfl.com/pro/item?MUrl=&PartUrl=ep20k200rc208-3v

Logic Element

The LE, the smallest unit of logic in the APEX 20K architecture, is compact and provides efficient logic usage. Each LE contains a four-input LUT, which is a function generator that can quickly implement any function of four variables. In addition, each LE contains a programmable register and carry and cascade chains. Each LE drives the local interconnect, MegaLAB interconnect, and FastTrack Interconnect routing structures. See [Figure 5](#).

Figure 5. APEX 20K Logic Element

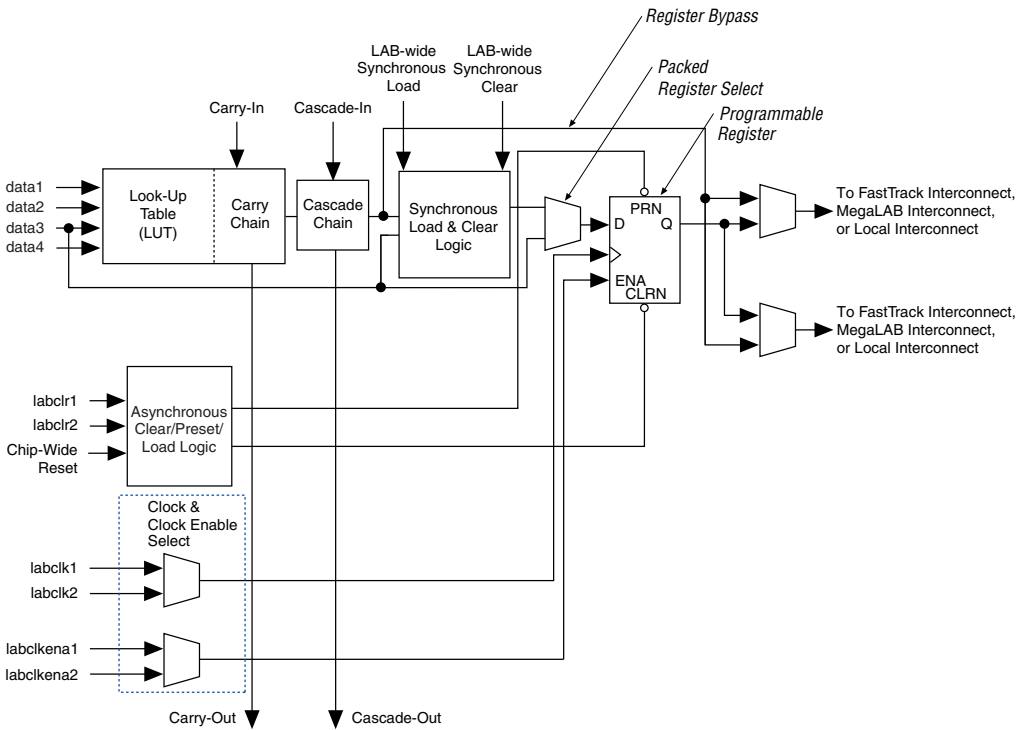

Each LE's programmable register can be configured for D, T, JK, or SR operation. The register's clock and clear control signals can be driven by global signals, general-purpose I/O pins, or any internal logic. For combinational functions, the register is bypassed and the output of the LUT drives the outputs of the LE.

Each LE has two outputs that drive the local, MegaLAB, or FastTrack Interconnect routing structure. Each output can be driven independently by the LUT's or register's output. For example, the LUT can drive one output while the register drives the other output. This feature, called register packing, improves device utilization because the register and the LUT can be used for unrelated functions. The LE can also drive out registered and unregistered versions of the LUT output.

The APEX 20K architecture provides two types of dedicated high-speed data paths that connect adjacent LEs without using local interconnect paths: carry chains and cascade chains. A carry chain supports high-speed arithmetic functions such as counters and adders, while a cascade chain implements wide-input functions such as equality comparators with minimum delay. Carry and cascade chains connect LEs 1 through 10 in an LAB and all LABs in the same MegaLAB structure.

Carry Chain

The carry chain provides a very fast carry-forward function between LEs. The carry-in signal from a lower-order bit drives forward into the higher-order bit via the carry chain, and feeds into both the LUT and the next portion of the carry chain. This feature allows the APEX 20K architecture to implement high-speed counters, adders, and comparators of arbitrary width. Carry chain logic can be created automatically by the Quartus II software Compiler during design processing, or manually by the designer during design entry. Parameterized functions such as library of parameterized modules (LPM) and DesignWare functions automatically take advantage of carry chains for the appropriate functions.

The Quartus II software Compiler creates carry chains longer than ten LEs by linking LABs together automatically. For enhanced fitting, a long carry chain skips alternate LABs in a MegaLAB™ structure. A carry chain longer than one LAB skips either from an even-numbered LAB to the next even-numbered LAB, or from an odd-numbered LAB to the next odd-numbered LAB. For example, the last LE of the first LAB in the upper-left MegaLAB structure carries to the first LE of the third LAB in the MegaLAB structure.

Figure 6 shows how an n -bit full adder can be implemented in $n + 1$ LEs with the carry chain. One portion of the LUT generates the sum of two bits using the input signals and the carry-in signal; the sum is routed to the output of the LE. The register can be bypassed for simple adders or used for accumulator functions. Another portion of the LUT and the carry chain logic generates the carry-out signal, which is routed directly to the carry-in signal of the next-higher-order bit. The final carry-out signal is routed to an LE, where it is driven onto the local, MegaLAB, or FastTrack Interconnect routing structures.

Figure 6. APEX 20K Carry Chain

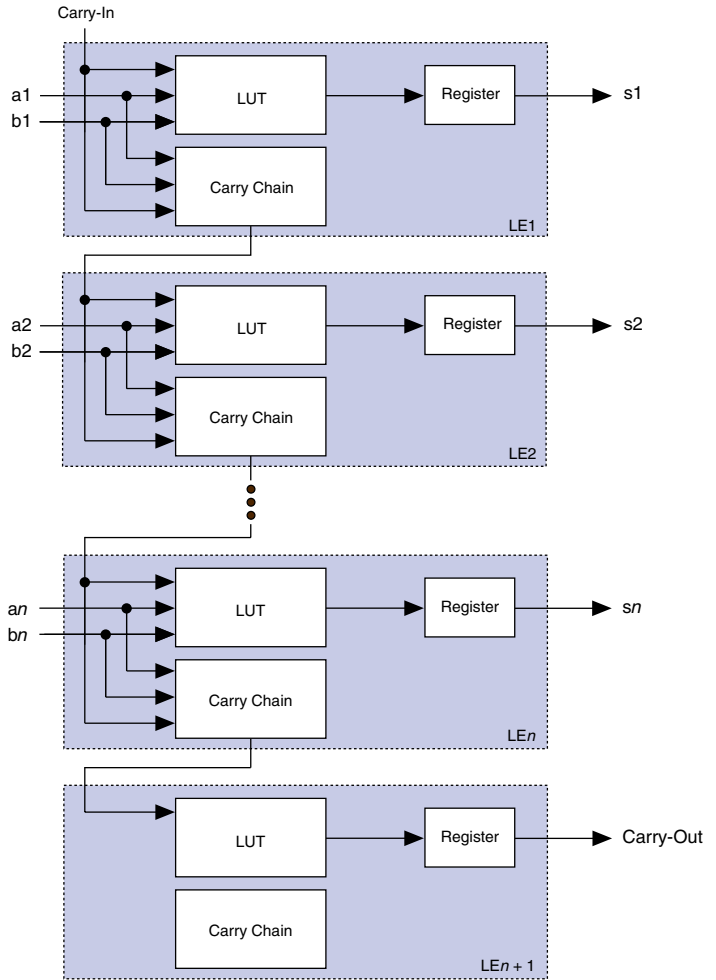
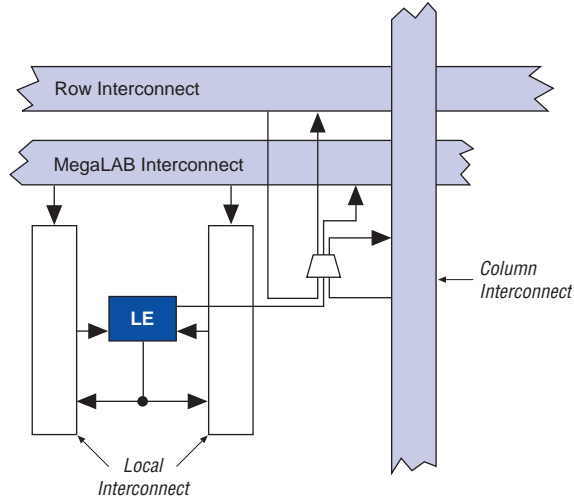

Figure 11 shows the intersection of a row and column interconnect, and how these forms of interconnects and LEs drive each other.

Figure 11. Driving the FastTrack Interconnect



APEX 20KE devices include an enhanced interconnect structure for faster routing of input signals with high fan-out. Column I/O pins can drive the FastRow™ interconnect, which routes signals directly into the local interconnect without having to drive through the MegaLAB interconnect. FastRow lines traverse two MegaLAB structures. Also, these pins can drive the local interconnect directly for fast setup times. On EP20K300E and larger devices, the FastRow interconnect drives the two MegaLABs in the top left corner, the two MegaLABs in the top right corner, the two MegaLABs in the bottom left corner, and the two MegaLABs in the bottom right corner. On EP20K200E and smaller devices, FastRow interconnect drives the two MegaLABs on the top and the two MegaLABs on the bottom of the device. On all devices, the FastRow interconnect drives all local interconnect in the appropriate MegaLABs except the local interconnect on the side of the MegaLAB opposite the ESB. Pins using the FastRow interconnect achieve a faster set-up time, as the signal does not need to use a MegaLAB interconnect line to reach the destination LE. Figure 12 shows the FastRow interconnect.



For more information on APEX 20KE devices and CAM, see *Application Note 119 (Implementing High-Speed Search Applications with APEX CAM)*.

Driving Signals to the ESB

ESBs provide flexible options for driving control signals. Different clocks can be used for the ESB inputs and outputs. Registers can be inserted independently on the data input, data output, read address, write address, WE, and RE signals. The global signals and the local interconnect can drive the WE and RE signals. The global signals, dedicated clock pins, and local interconnect can drive the ESB clock signals. Because the LEs drive the local interconnect, the LEs can control the WE and RE signals and the ESB clock, clock enable, and asynchronous clear signals. [Figure 24](#) shows the ESB control signal generation logic.

Figure 24. ESB Control Signal Generation

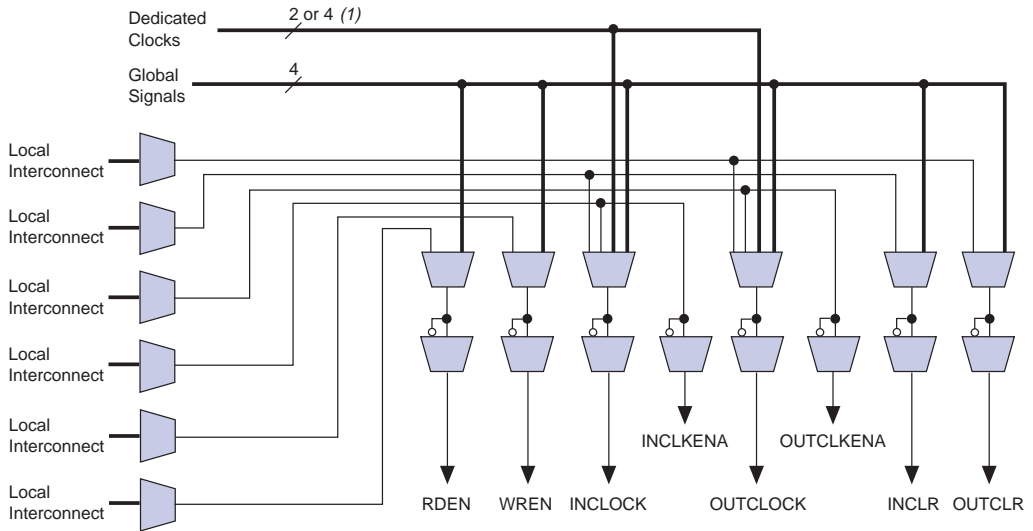

Note to Figure 24:

(1) APEX 20KE devices have four dedicated clocks.

An ESB is fed by the local interconnect, which is driven by adjacent LEs (for high-speed connection to the ESB) or the MegaLAB interconnect. The ESB can drive the local, MegaLAB, or FastTrack Interconnect routing structure to drive LEs and IOEs in the same MegaLAB structure or anywhere in the device.

Implementing Logic in ROM

In addition to implementing logic with product terms, the ESB can implement logic functions when it is programmed with a read-only pattern during configuration, creating a large LUT. With LUTs, combinatorial functions are implemented by looking up the results, rather than by computing them. This implementation of combinatorial functions can be faster than using algorithms implemented in general logic, a performance advantage that is further enhanced by the fast access times of ESBs. The large capacity of ESBs enables designers to implement complex functions in one logic level without the routing delays associated with linked LEs or distributed RAM blocks. Parameterized functions such as LPM functions can take advantage of the ESB automatically. Further, the Quartus II software can implement portions of a design with ESBs where appropriate.

Programmable Speed/Power Control

APEX 20K ESBs offer a high-speed mode that supports very fast operation on an ESB-by-ESB basis. When high speed is not required, this feature can be turned off to reduce the ESB's power dissipation by up to 50%. ESBs that run at low power incur a nominal timing delay adder. This Turbo Bit™ option is available for ESBs that implement product-term logic or memory functions. An ESB that is not used will be powered down so that it does not consume DC current.

Designers can program each ESB in the APEX 20K device for either high-speed or low-power operation. As a result, speed-critical paths in the design can run at high speed, while the remaining paths operate at reduced power.

I/O Structure

The APEX 20K IOE contains a bidirectional I/O buffer and a register that can be used either as an input register for external data requiring fast setup times, or as an output register for data requiring fast clock-to-output performance. IOEs can be used as input, output, or bidirectional pins. For fast bidirectional I/O timing, LE registers using local routing can improve setup times and OE timing. The Quartus II software Compiler uses the programmable inversion option to invert signals from the row and column interconnect automatically where appropriate. Because the APEX 20K IOE offers one output enable per pin, the Quartus II software Compiler can emulate open-drain operation efficiently.

The APEX 20K IOE includes programmable delays that can be activated to ensure zero hold times, minimum clock-to-output times, input IOE register-to-core register transfers, or core-to-output IOE register transfers. A path in which a pin directly drives a register may require the delay to ensure zero hold time, whereas a path in which a pin drives a register through combinatorial logic may not require the delay.

Table 10 describes the APEX 20K programmable delays and their logic options in the Quartus II software.

Table 10. APEX 20K Programmable Delay Chains	
Programmable Delays	Quartus II Logic Option
Input pin to core delay	Decrease input delay to internal cells
Input pin to input register delay	Decrease input delay to input register
Core to output register delay	Decrease input delay to output register
Output register t_{CO} delay	Increase delay to output pin

The Quartus II software compiler can program these delays automatically to minimize setup time while providing a zero hold time. Figure 25 shows how fast bidirectional I/Os are implemented in APEX 20K devices.

The register in the APEX 20K IOE can be programmed to power-up high or low after configuration is complete. If it is programmed to power-up low, an asynchronous clear can control the register. If it is programmed to power-up high, the register cannot be asynchronously cleared or preset. This feature is useful for cases where the APEX 20K device controls an active-low input or another device; it prevents inadvertent activation of the input upon power-up.

APEX 20KE devices include an enhanced IOE, which drives the FastRow interconnect. The FastRow interconnect connects a column I/O pin directly to the LAB local interconnect within two MegaLAB structures. This feature provides fast setup times for pins that drive high fan-outs with complex logic, such as PCI designs. For fast bidirectional I/O timing, LE registers using local routing can improve setup times and OE timing. The APEX 20KE IOE also includes direct support for open-drain operation, giving faster clock-to-output for open-drain signals. Some programmable delays in the APEX 20KE IOE offer multiple levels of delay to fine-tune setup and hold time requirements. The Quartus II software compiler can set these delays automatically to minimize setup time while providing a zero hold time.

Table 11 describes the APEX 20KE programmable delays and their logic options in the Quartus II software.

<i>Table 11. APEX 20KE Programmable Delay Chains</i>	
Programmable Delays	Quartus II Logic Option
Input Pin to Core Delay	Decrease input delay to internal cells
Input Pin to Input Register Delay	Decrease input delay to input registers
Core to Output Register Delay	Decrease input delay to output register
Output Register t_{CO} Delay	Increase delay to output pin
Clock Enable Delay	Increase clock enable delay

The register in the APEX 20KE IOE can be programmed to power-up high or low after configuration is complete. If it is programmed to power-up low, an asynchronous clear can control the register. If it is programmed to power-up high, an asynchronous preset can control the register. Figure 26 shows how fast bidirectional I/O pins are implemented in APEX 20KE devices. This feature is useful for cases where the APEX 20KE device controls an active-low input or another device; it prevents inadvertent activation of the input upon power-up.

Figure 26. APEX 20KE Bidirectional I/O Registers Notes (1), (2)

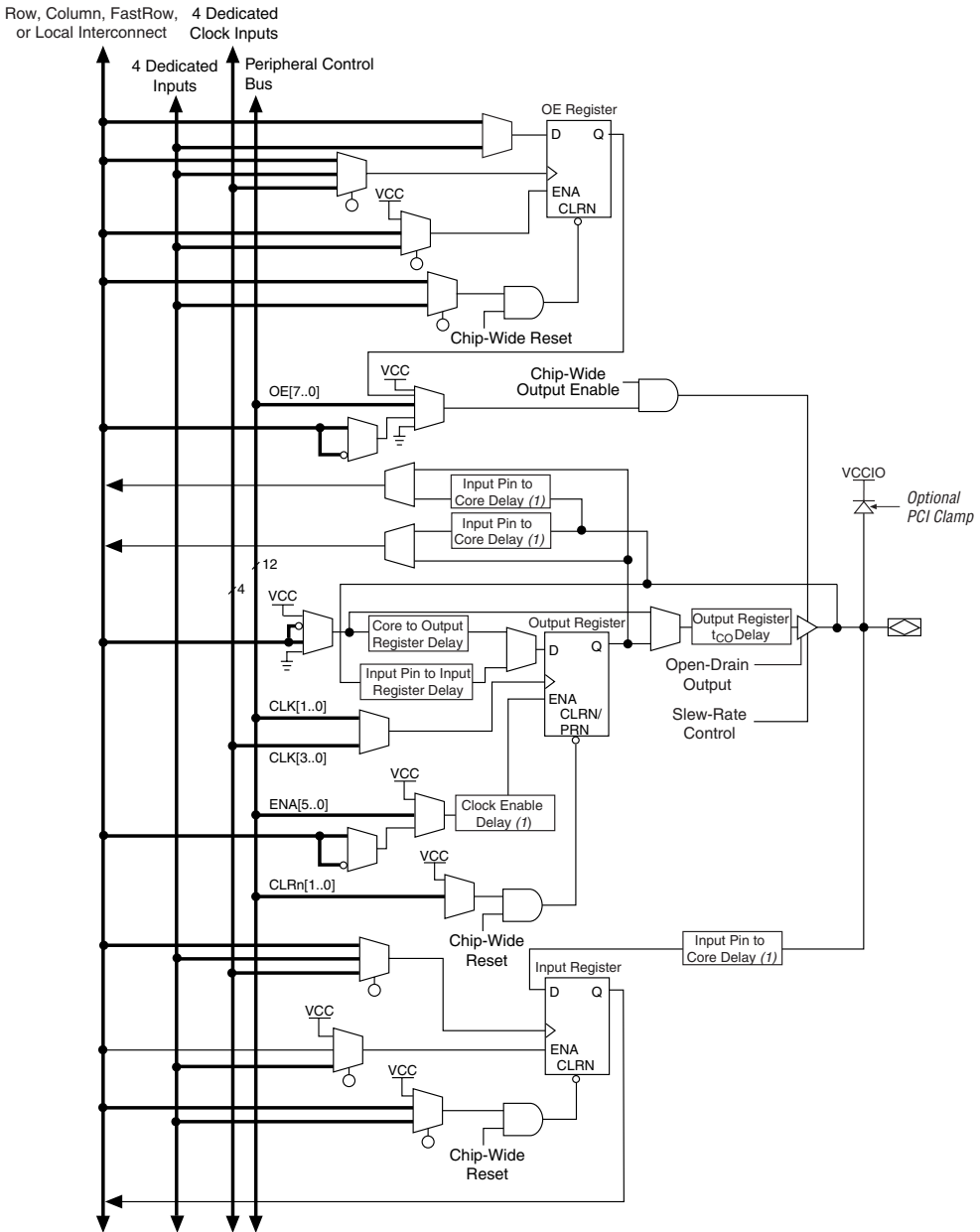

Notes to Figure 26:

- (1) This programmable delay has four settings: off and three levels of delay.
- (2) The output enable and input registers are LE registers in the LAB adjacent to the bidirectional pin.

Figure 29. APEX 20KE I/O Banks

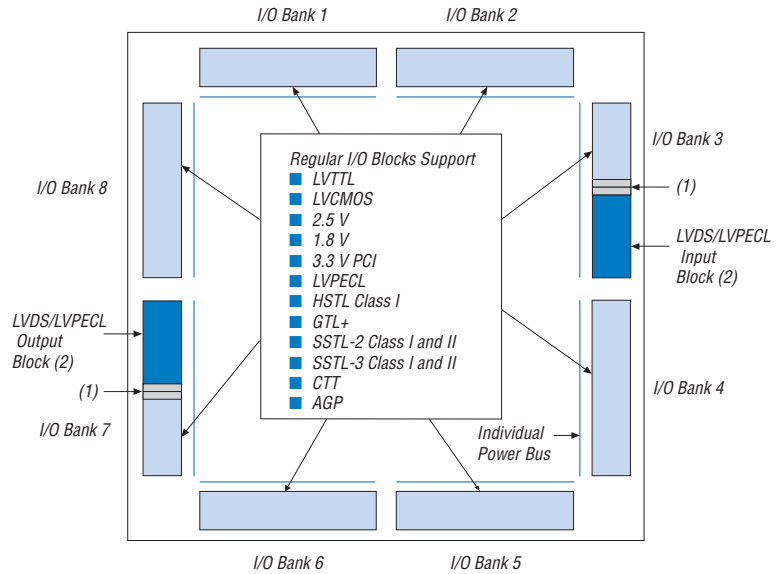

Notes to Figure 29:

- (1) For more information on placing I/O pins in LVDS blocks, refer to the *Guidelines for Using LVDS Blocks* section in *Application Note 120 (Using LVDS in APEX 20KE Devices)*.
- (2) If the LVDS input and output blocks are not used for LVDS, they can support all of the I/O standards and can be used as input, output, or bidirectional pins with V_{CCIO} set to 3.3 V, 2.5 V, or 1.8 V.

Power Sequencing & Hot Socketing

Because APEX 20K and APEX 20KE devices can be used in a mixed-voltage environment, they have been designed specifically to tolerate any possible power-up sequence. Therefore, the V_{CCIO} and V_{CCINT} power supplies may be powered in any order.



For more information, please refer to the “Power Sequencing Considerations” section in the *Configuring APEX 20KE & APEX 20KC Devices* chapter of the *Configuration Devices Handbook*.

Signals can be driven into APEX 20K devices before and during power-up without damaging the device. In addition, APEX 20K devices do not drive out during power-up. Once operating conditions are reached and the device is configured, APEX 20K and APEX 20KE devices operate as specified by the user.

IEEE Std. 1149.1 (JTAG) Boundary-Scan Support

All APEX 20K devices provide JTAG BST circuitry that complies with the IEEE Std. 1149.1-1990 specification. JTAG boundary-scan testing can be performed before or after configuration, but not during configuration. APEX 20K devices can also use the JTAG port for configuration with the Quartus II software or with hardware using either Jam Files (.jam) or Jam Byte-Code Files (.jbc). Finally, APEX 20K devices use the JTAG port to monitor the logic operation of the device with the SignalTap embedded logic analyzer. APEX 20K devices support the JTAG instructions shown in Table 19. Although EP20K1500E devices support the JTAG BYPASS and SignalTap instructions, they do not support boundary-scan testing or the use of the JTAG port for configuration.

Table 19. APEX 20K JTAG Instructions

JTAG Instruction	Description
SAMPLE/PRELOAD	Allows a snapshot of signals at the device pins to be captured and examined during normal device operation, and permits an initial data pattern to be output at the device pins. Also used by the SignalTap embedded logic analyzer.
EXTEST	Allows the external circuitry and board-level interconnections to be tested by forcing a test pattern at the output pins and capturing test results at the input pins.
BYPASS (1)	Places the 1-bit bypass register between the TDI and TDO pins, which allows the BST data to pass synchronously through selected devices to adjacent devices during normal device operation.
USERCODE	Selects the 32-bit USERCODE register and places it between the TDI and TDO pins, allowing the USERCODE to be serially shifted out of TDO.
IDCODE	Selects the IDCODE register and places it between TDI and TDO, allowing the IDCODE to be serially shifted out of TDO.
ICR Instructions	Used when configuring an APEX 20K device via the JTAG port with a MasterBlaster™ or ByteBlasterMV™ download cable, or when using a Jam File or Jam Byte-Code File via an embedded processor.
SignalTap Instructions (1)	Monitors internal device operation with the SignalTap embedded logic analyzer.

Note to Table 19:

(1) The EP20K1500E device supports the JTAG BYPASS instruction and the SignalTap instructions.

Table 26. APEX 20K 5.0-V Tolerant Device Capacitance Notes (2), (14)

Symbol	Parameter	Conditions	Min	Max	Unit
C_{IN}	Input capacitance	$V_{IN} = 0\text{ V}$, $f = 1.0\text{ MHz}$		8	pF
C_{INCLK}	Input capacitance on dedicated clock pin	$V_{IN} = 0\text{ V}$, $f = 1.0\text{ MHz}$		12	pF
C_{OUT}	Output capacitance	$V_{OUT} = 0\text{ V}$, $f = 1.0\text{ MHz}$		8	pF

Notes to Tables 23 through 26:

- (1) See the *Operating Requirements for Altera Devices Data Sheet*.
- (2) All APEX 20K devices are 5.0-V tolerant.
- (3) Minimum DC input is -0.5 V . During transitions, the inputs may undershoot to -2.0 V or overshoot to 5.75 V for input currents less than 100 mA and periods shorter than 20 ns .
- (4) Numbers in parentheses are for industrial-temperature-range devices.
- (5) Maximum V_{CC} rise time is 100 ms , and V_{CC} must rise monotonically.
- (6) All pins, including dedicated inputs, clock I/O, and JTAG pins, may be driven before V_{CCINT} and V_{CCIO} are powered.
- (7) Typical values are for $T_A = 25^\circ\text{ C}$, $V_{CCINT} = 2.5\text{ V}$, and $V_{CCIO} = 2.5$ or 3.3 V .
- (8) These values are specified in the APEX 20K device recommended operating conditions, shown in Table 26 on page 62.
- (9) The APEX 20K input buffers are compatible with 2.5-V and 3.3-V (LVTTTL and LVCMOS) signals. Additionally, the input buffers are 3.3-V PCI compliant when V_{CCIO} and V_{CCINT} meet the relationship shown in Figure 33 on page 68.
- (10) The I_{OH} parameter refers to high-level TTL, PCI or CMOS output current.
- (11) The I_{OL} parameter refers to low-level TTL, PCI, or CMOS output current. This parameter applies to open-drain pins as well as output pins.
- (12) This value is specified for normal device operation. The value may vary during power-up.
- (13) Pin pull-up resistance values will be lower if an external source drives the pin higher than V_{CCIO} .
- (14) Capacitance is sample-tested only.

Tables 27 through 30 provide information on absolute maximum ratings, recommended operating conditions, DC operating conditions, and capacitance for 1.8-V APEX 20KE devices.

Table 27. APEX 20KE Device Absolute Maximum Ratings Note (1)

Symbol	Parameter	Conditions	Min	Max	Unit
V_{CCINT}	Supply voltage	With respect to ground (2)	-0.5	2.5	V
V_{CCIO}			-0.5	4.6	V
V_I			DC input voltage	-0.5	4.6
I_{OUT}	DC output current, per pin		-25	25	mA
T_{STG}	Storage temperature	No bias	-65	150	$^\circ\text{ C}$
T_{AMB}	Ambient temperature	Under bias	-65	135	$^\circ\text{ C}$
T_J	Junction temperature	PQFP, RQFP, TQFP, and BGA packages, under bias		135	$^\circ\text{ C}$
		Ceramic PGA packages, under bias		150	$^\circ\text{ C}$

Table 36. APEX 20KE Routing Timing Microparameters *Note (1)*

Symbol	Parameter
t_{F1-4}	Fanout delay using Local Interconnect
t_{F5-20}	Fanout delay estimate using MegaLab Interconnect
t_{F20+}	Fanout delay estimate using FastTrack Interconnect

Note to Table 36:

- (1) These parameters are worst-case values for typical applications. Post-compilation timing simulation and timing analysis are required to determine actual worst-case performance.

Table 37. APEX 20KE Functional Timing Microparameters

Symbol	Parameter
TCH	Minimum clock high time from clock pin
TCL	Minimum clock low time from clock pin
TCLRP	LE clear Pulse Width
TPREP	LE preset pulse width
TESBCH	Clock high time for ESB
TESBCL	Clock low time for ESB
TESBWP	Write pulse width
TESBRP	Read pulse width

Tables 38 and 39 describe the APEX 20KE external timing parameters.

Table 38. APEX 20KE External Timing Parameters *Note (1)*

Symbol	Clock Parameter	Conditions
t_{INSU}	Setup time with global clock at IOE input register	
t_{INH}	Hold time with global clock at IOE input register	
t_{OUTCO}	Clock-to-output delay with global clock at IOE output register	C1 = 10 pF
$t_{INSUPLL}$	Setup time with PLL clock at IOE input register	
t_{INHPLL}	Hold time with PLL clock at IOE input register	
$t_{OUTCOPLL}$	Clock-to-output delay with PLL clock at IOE output register	C1 = 10 pF

Table 52. EP20K30E Minimum Pulse Width Timing Parameters

Symbol	-1		-2		-3		Unit
	Min	Max	Min	Max	Min	Max	
t _{CH}	0.55		0.78		1.15		ns
t _{CL}	0.55		0.78		1.15		ns
t _{CLRP}	0.22		0.31		0.46		ns
t _{PREP}	0.22		0.31		0.46		ns
t _{ESBCH}	0.55		0.78		1.15		ns
t _{ESBCL}	0.55		0.78		1.15		ns
t _{ESBWP}	1.43		2.01		2.97		ns
t _{ESBRP}	1.15		1.62		2.39		ns

Table 53. EP20K30E External Timing Parameters

Symbol	-1		-2		-3		Unit
	Min	Max	Min	Max	Min	Max	
t _{INSU}	2.02		2.13		2.24		ns
t _{INH}	0.00		0.00		0.00		ns
t _{OUTCO}	2.00	4.88	2.00	5.36	2.00	5.88	ns
t _{INSUPLL}	2.11		2.23		-		ns
t _{INHPLL}	0.00		0.00		-		ns
t _{OUTCOPLL}	0.50	2.60	0.50	2.88	-	-	ns

Table 54. EP20K30E External Bidirectional Timing Parameters

Symbol	-1		-2		-3		Unit
	Min	Max	Min	Max	Min	Max	
t _{INSUBIDIR}	1.85		1.77		1.54		ns
t _{INHBIDIR}	0.00		0.00		0.00		ns
t _{OUTCOBIDIR}	2.00	4.88	2.00	5.36	2.00	5.88	ns
t _{XZBIDIR}		7.48		8.46		9.83	ns
t _{ZXBIDIR}		7.48		8.46		9.83	ns
t _{INSUBIDIRPLL}	4.12		4.24		-		ns
t _{INHBIDIRPLL}	0.00		0.00		-		ns
t _{OUTCOBIDIRPLL}	0.50	2.60	0.50	2.88	-	-	ns
t _{XZBIDIRPLL}		5.21		5.99		-	ns
t _{ZXBIDIRPLL}		5.21		5.99		-	ns

Tables 55 through 60 describe f_{MAX} LE Timing Microparameters, f_{MAX} ESB Timing Microparameters, f_{MAX} Routing Delays, Minimum Pulse Width Timing Parameters, External Timing Parameters, and External Bidirectional Timing Parameters for EP20K60E APEX 20KE devices.

Table 55. EP20K60E f_{MAX} LE Timing Microparameters

Symbol	-1		-2		-3		Unit
	Min	Max	Min	Max	Min	Max	
t_{SU}	0.17		0.15		0.16		ns
t_H	0.32		0.33		0.39		ns
t_{CO}		0.29		0.40		0.60	ns
t_{LUT}		0.77		1.07		1.59	ns

Table 56. EP20K60E f_{MAX} ESB Timing Microparameters

Symbol	-1		-2		-3		Unit
	Min	Max	Min	Max	Min	Max	
t_{ESBARC}		1.83		2.57		3.79	ns
t_{ESBSRC}		2.46		3.26		4.61	ns
t_{ESBAWC}		3.50		4.90		7.23	ns
t_{ESBSWC}		3.77		4.90		6.79	ns
$t_{ESBWASU}$	1.59		2.23		3.29		ns
t_{ESBWAH}	0.00		0.00		0.00		ns
$t_{ESBWDSU}$	1.75		2.46		3.62		ns
t_{ESBWDH}	0.00		0.00		0.00		ns
$t_{ESBRASU}$	1.76		2.47		3.64		ns
t_{ESBRAH}	0.00		0.00		0.00		ns
$t_{ESBWESU}$	1.68		2.49		3.87		ns
t_{ESBWEH}	0.00		0.00		0.00		ns
$t_{ESBDATASU}$	0.08		0.43		1.04		ns
$t_{ESBDATAH}$	0.13		0.13		0.13		ns
$t_{ESBWADDRSU}$	0.29		0.72		1.46		ns
$t_{ESBRADDRSU}$	0.36		0.81		1.58		ns
$t_{ESBDATACO1}$		1.06		1.24		1.55	ns
$t_{ESBDATACO2}$		2.39		3.35		4.94	ns
t_{ESBDD}		3.50		4.90		7.23	ns
t_{PD}		1.72		2.41		3.56	ns
$t_{PTERMSU}$	0.99		1.56		2.55		ns
$t_{PTERMCO}$		1.07		1.26		1.08	ns

Table 60. EP20K60E External Bidirectional Timing Parameters

Symbol	-1		-2		-3		Unit
	Min	Max	Min	Max	Min	Max	
$t_{\text{INSUBIDIR}}$	2.77		2.91		3.11		ns
t_{INHBDIR}	0.00		0.00		0.00		ns
$t_{\text{OUTCOBIDIR}}$	2.00	4.84	2.00	5.31	2.00	5.81	ns
t_{XZBIDIR}		6.47		7.44		8.65	ns
t_{ZXBIDIR}		6.47		7.44		8.65	ns
$t_{\text{INSUBIDIRPLL}}$	3.44		3.24		-		ns
$t_{\text{INHBDIRPLL}}$	0.00		0.00		-		ns
$t_{\text{OUTCOBIDIRPLL}}$	0.50	3.37	0.50	3.69	-	-	ns
$t_{\text{XZBIDIRPLL}}$		5.00		5.82		-	ns
$t_{\text{ZXBIDIRPLL}}$		5.00		5.82		-	ns

Tables 61 through 66 describe f_{MAX} LE Timing Microparameters, f_{MAX} ESB Timing Microparameters, f_{MAX} Routing Delays, Minimum Pulse Width Timing Parameters, External Timing Parameters, and External Bidirectional Timing Parameters for EP20K100E APEX 20KE devices.

Table 61. EP20K100E f_{MAX} LE Timing Microparameters

Symbol	-1		-2		-3		Unit
	Min	Max	Min	Max	Min	Max	
t_{SU}	0.25		0.25		0.25		ns
t_{H}	0.25		0.25		0.25		ns
t_{CO}		0.28		0.28		0.34	ns
t_{LUT}		0.80		0.95		1.13	ns

Tables 85 through 90 describe f_{MAX} LE Timing Microparameters, f_{MAX} ESB Timing Microparameters, f_{MAX} Routing Delays, Minimum Pulse Width Timing Parameters, External Timing Parameters, and External Bidirectional Timing Parameters for EP20K400E APEX 20KE devices.

Table 85. EP20K400E f_{MAX} LE Timing Microparameters							
Symbol	-1 Speed Grade		-2 Speed Grade		-3 Speed Grade		Unit
	Min	Max	Min	Max	Min	Max	
t_{SU}	0.23		0.23		0.23		ns
t_H	0.23		0.23		0.23		ns
t_{CO}		0.25		0.29		0.32	ns
t_{LUT}		0.70		0.83		1.01	ns

Tables 97 through 102 describe f_{MAX} LE Timing Microparameters, f_{MAX} ESB Timing Microparameters, f_{MAX} Routing Delays, Minimum Pulse Width Timing Parameters, External Timing Parameters, and External Bidirectional Timing Parameters for EP20K1000E APEX 20KE devices.

Table 97. EP20K1000E f_{MAX} LE Timing Microparameters							
Symbol	-1 Speed Grade		-2 Speed Grade		-3 Speed Grade		Unit
	Min	Max	Min	Max	Min	Max	
t_{SU}	0.25		0.25		0.25		ns
t_H	0.25		0.25		0.25		ns
t_{CO}		0.28		0.32		0.33	ns
t_{LUT}		0.80		0.95		1.13	ns

Revision History

The information contained in the *APEX 20K Programmable Logic Device Family Data Sheet* version 5.1 supersedes information published in previous versions.

Version 5.1

APEX 20K Programmable Logic Device Family Data Sheet version 5.1 contains the following changes:

- In version 5.0, the VI input voltage spec was updated in Table 28 on page 63.
- In version 5.0, *Note (5)* to Tables 27 through 30 was revised.
- Added *Note (2)* to Figure 21 on page 33.

Version 5.0

APEX 20K Programmable Logic Device Family Data Sheet version 5.0 contains the following changes:

- Updated Tables 23 through 26. Removed 2.5-V operating condition tables because all APEX 20K devices are now 5.0-V tolerant.
- Updated conditions in Tables 33, 38 and 39.
- Updated data for $t_{ESB\text{DATAH}}$ parameter.

Version 4.3

APEX 20K Programmable Logic Device Family Data Sheet version 4.3 contains the following changes:

- Updated Figure 20.
- Updated *Note (2)* to Table 13.
- Updated notes to Tables 27 through 30.

Version 4.2

APEX 20K Programmable Logic Device Family Data Sheet version 4.2 contains the following changes:

- Updated Figure 29.
- Updated *Note (1)* to Figure 29.