

Welcome to [E-XFL.COM](https://www.e-xfl.com)

Understanding **Embedded - FPGAs (Field Programmable Gate Array)**

Embedded - FPGAs, or Field Programmable Gate Arrays, are advanced integrated circuits that offer unparalleled flexibility and performance for digital systems. Unlike traditional fixed-function logic devices, FPGAs can be programmed and reprogrammed to execute a wide array of logical operations, enabling customized functionality tailored to specific applications. This reprogrammability allows developers to iterate designs quickly and implement complex functions without the need for custom hardware.

Applications of Embedded - FPGAs

The versatility of Embedded - FPGAs makes them indispensable in numerous fields. In telecommunications.

Details

Product Status	Active
Number of LABs/CLBs	1500
Number of Logic Elements/Cells	12000
Total RAM Bits	226304
Number of I/O	193
Number of Gates	-
Voltage - Supply	1.14V ~ 1.26V
Mounting Type	Surface Mount
Operating Temperature	-40°C ~ 100°C (TJ)
Package / Case	256-BGA
Supplier Device Package	256-FPBGA (17x17)
Purchase URL	https://www.e-xfl.com/product-detail/lattice-semiconductor/lfe2-12se-5fn256i

Edge Clock Sources

Edge clock resources can be driven from a variety of sources at the same edge. Edge clock resources can be driven from adjacent edge clock PIOs, primary clock PIOs, PLLs/DLLs and clock dividers as shown in Figure 2-12.

Figure 2-12. Edge Clock Sources

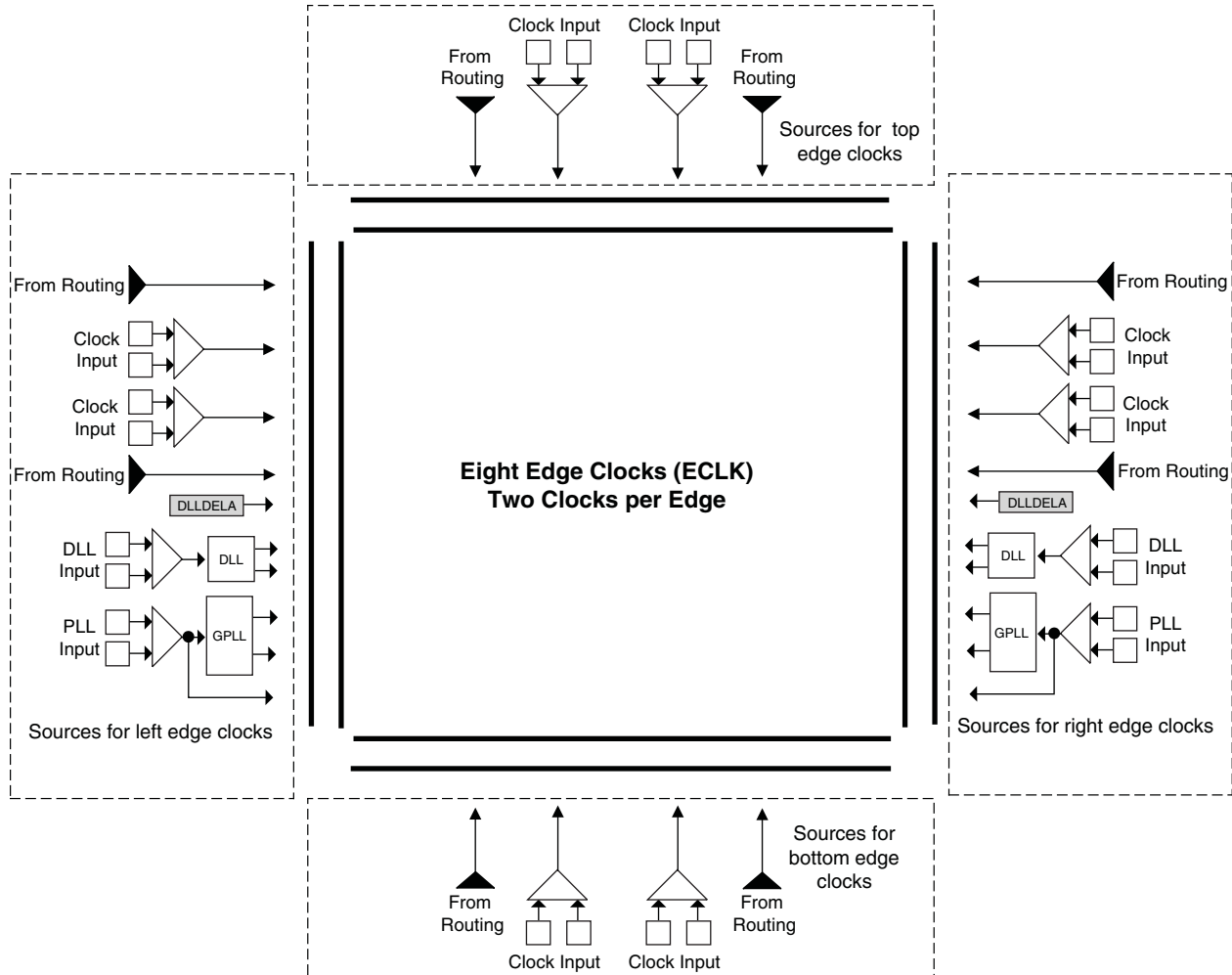

LatticeECP2/M DSP Performance

Table 2-11 lists the maximum performance in millions of MAC operations per second (MMAC) for each member of the LatticeECP2/M family.

Table 2-11. DSP Performance

Device	DSP Block	DSP Performance GMAC
ECP2-6	3	3.9
ECP2-12	6	7.8
ECP2-20	7	9.1
ECP2-35	8	10.4
ECP2-50	18	23.4
ECP2-70	22	28.6
ECP2M20	6	7.8
ECP2M35	8	10.4
ECP2M50	22	28.6
ECP2M70	24	31.2
ECP2M100	42	54.6

For further information about the sysDSP block, please see the list of additional technical information at the end of this data sheet.

Programmable I/O Cells (PIC)

Each PIC contains two PIOs connected to their respective sysI/O buffers as shown in Figure 2-28. The PIO Block supplies the output data (DO) and the tri-state control signal (TO) to the sysI/O buffer and receives input from the buffer. Table 2-12 provides the PIO signal list.

Figure 2-28. PIC Diagram

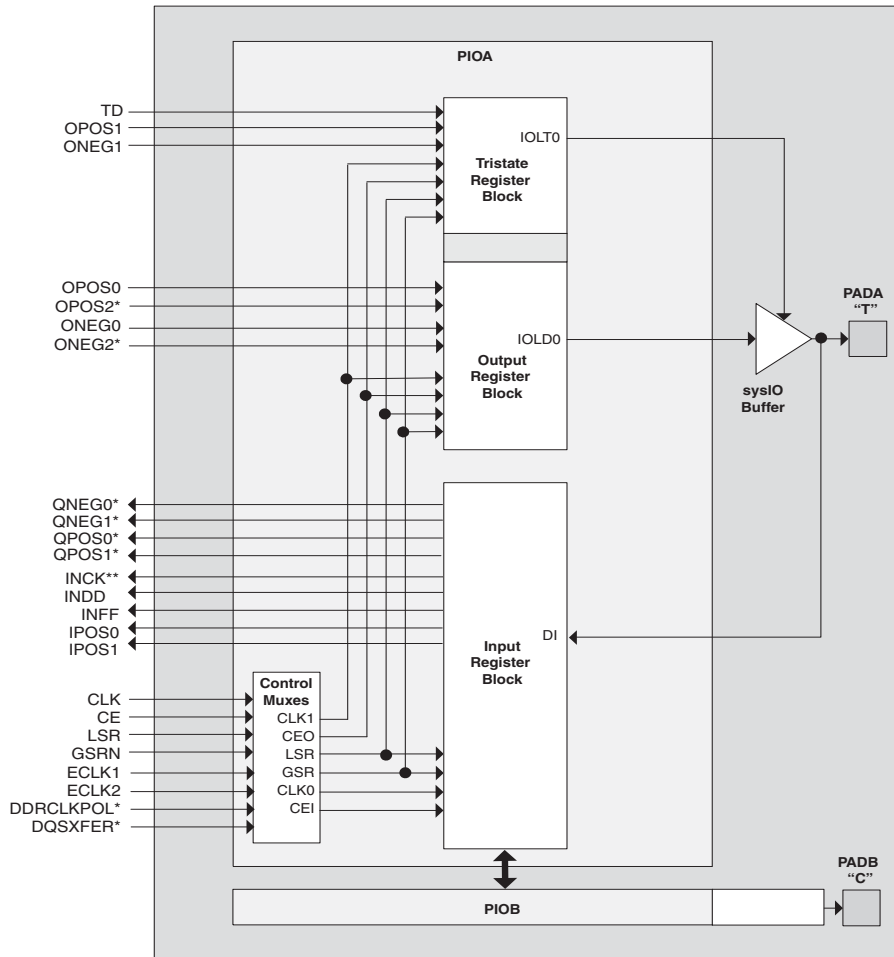

*Signals are available on left/right/bottom edges only.
** Selected blocks.

Two adjacent PIOs can be joined to provide a differential I/O pair (labeled as "T" and "C") as shown in Figure 2-28. The PAD Labels "T" and "C" distinguish the two PIOs. Approximately 50% of the PIO pairs on the left and right edges of the device can be configured as true LVDS outputs. All I/O pairs can operate as inputs.

IEEE 1149.1-Compliant Boundary Scan Testability

All LatticeECP2/M devices have boundary scan cells that are accessed through an IEEE 1149.1 compliant Test Access Port (TAP). This allows functional testing of the circuit board, on which the device is mounted, through a serial scan path that can access all critical logic nodes. Internal registers are linked internally, allowing test data to be shifted in and loaded directly onto test nodes, or test data to be captured and shifted out for verification. The test access port consists of dedicated I/Os: TDI, TDO, TCK and TMS. The test access port has its own supply voltage V_{CCJ} and can operate with LVCMOS3.3, 2.5, 1.8, 1.5 and 1.2 standards.

For more details on boundary scan test, please see information regarding additional technical documentation at the end of this data sheet.

Device Configuration

All LatticeECP2/M devices contain two ports that can be used for device configuration. The Test Access Port (TAP), which supports bit-wide configuration, and the sysCONFIG port, support both byte-wide and serial configuration, including the standard SPI Flash interface. The TAP supports both the IEEE Standard 1149.1 Boundary Scan specification and the IEEE Standard 1532 In-System Configuration specification. The sysCONFIG port is a 20-pin interface with six I/Os used as dedicated pins with the remainder used as dual-use pins. See TN1108, [LatticeECP2/M sysCONFIG Usage Guide](#) for more information about using the dual-use pins as general purpose I/Os.

On power-up, the FPGA SRAM is ready to be configured using the selected sysCONFIG port. Once a configuration port is selected, it will remain active throughout that configuration cycle. The IEEE 1149.1 port can be activated any time after power-up by sending the appropriate command through the TAP port.

Enhanced Configuration Option

LatticeECP2/M devices have enhanced configuration features such as: decryption support, TransFR™ I/O and dual boot image support.

1. Decryption Support

LatticeECP2/M devices provide on-chip, One Time Programmable (OTP) non-volatile key storage to support decryption of a 128-bit AES encrypted bitstream, securing designs and deterring design piracy.

2. TransFR (Transparent Field Reconfiguration)

TransFR I/O (TFR) is a unique Lattice technology that allows users to update their logic in the field without interrupting system operation using a single ispVM® command. TransFR I/O allows I/O states to be frozen during device configuration. This allows the device to be field updated with a minimum of system disruption and downtime. See TN1087, [Minimizing System Interruption During Configuration Using TransFR Technology](#), for details.

3. Dual Boot Image Support

Dual boot images are supported for applications requiring reliable remote updates of configuration data for the system FPGA. After the system is running with a basic configuration, a new boot image can be downloaded remotely and stored in a separate location in the configuration storage device. Any time after the update the LatticeECP2/M can be re-booted from this new configuration file. If there is a problem, such as corrupt data during download or incorrect version number with this new boot image, the LatticeECP2/M device can revert back to the original backup configuration and try again. This all can be done without power cycling the system.

For more information about device configuration, please see the list of additional technical documentation at the end of this data sheet.

Soft Error Detect (SED) Support

LatticeECP2/M devices have dedicated logic to perform CRC checks. During configuration, the configuration data bitstream can be checked with the CRC logic block. In addition, the LatticeECP2 device can also be programmed



LatticeECP2/M Family Data Sheet DC and Switching Characteristics

September 2013

Data Sheet DS1006

Absolute Maximum Ratings^{1, 2, 3}

Supply Voltage V_{CC}	-0.5 to 1.32V
Supply Voltage V_{CCAUX}	-0.5 to 3.75V
Supply Voltage V_{CCJ}	-0.5 to 3.75V
Output Supply Voltage V_{CCIO}	-0.5 to 3.75V
Input or I/O Tristate Voltage Applied ⁴	-0.5 to 3.75V
Storage Temperature (Ambient)	-65 to 150°C
Junction Temperature (Tj)	+125°C

1. Stress above those listed under the “Absolute Maximum Ratings” may cause permanent damage to the device. Functional operation of the device at these or any other conditions above those indicated in the operational sections of this specification is not implied.
2. Compliance with the Lattice [Thermal Management](#) document is required.
3. All voltages referenced to GND.
4. Overshoot and undershoot of -2V to ($V_{IHMAX} + 2$) volts is permitted for a duration of <20ns.

Recommended Operating Conditions⁷

Symbol	Parameter	Min.	Max.	Units
$V_{CC}^{1, 4, 5}$	Core Supply Voltage	1.14	1.26	V
$V_{CCAUX}^{1, 3, 4, 5}$	Auxiliary Supply Voltage	3.135	3.465	V
V_{CCPLL}	PLL Supply Voltage	1.14	1.26	V
$V_{CCIO}^{1, 2, 4}$	I/O Driver Supply Voltage	1.14	3.465	V
V_{CCJ}^1	Supply Voltage for IEEE 1149.1 Test Access Port	1.14	3.465	V
t_{JCOM}	Junction Temperature, Commercial Operation	0	85	°C
t_{JIND}	Junction Temperature, Industrial Operation	-40	100	°C
SERDES External Power Supply (For LatticeECP2M Family Only)				
V_{CCIB}	Input Buffer Power Supply (1.2V)	1.14	1.26	V
	Input Buffer Power Supply (1.5V)	1.425	1.575	V
V_{CCOB}	Output Buffer Power Supply (1.2V)	1.14	1.26	V
	Output Buffer Power Supply (1.5V)	1.425	1.575	V
$V_{CCAUX33}$	Termination Resistor Switching Power Supply	3.135	3.465	V
$V_{CCR\!X}^6$	Receive Power Supply	1.14	1.26	V
$V_{CCT\!X}^6$	Transmit Power Supply	1.14	1.26	V

© 2013 Lattice Semiconductor Corp. All Lattice trademarks, registered trademarks, patents, and disclaimers are as listed at www.latticesemi.com/legal. All other brand or product names are trademarks or registered trademarks of their respective holders. The specifications and information herein are subject to change without notice.

RSDS

The LatticeECP2/M devices support differential RSDS standard. This standard is emulated using complementary LVCMOS outputs in conjunction with a parallel resistor across the driver outputs. The RSDS input standard is supported by the LVDS differential input buffer. The scheme shown in Figure 3-4 is one possible solution for RSDS standard implementation. Resistor values in Figure 3-4 are industry standard values for 1% resistors.

Figure 3-4. RSDS (Reduced Swing Differential Signaling)

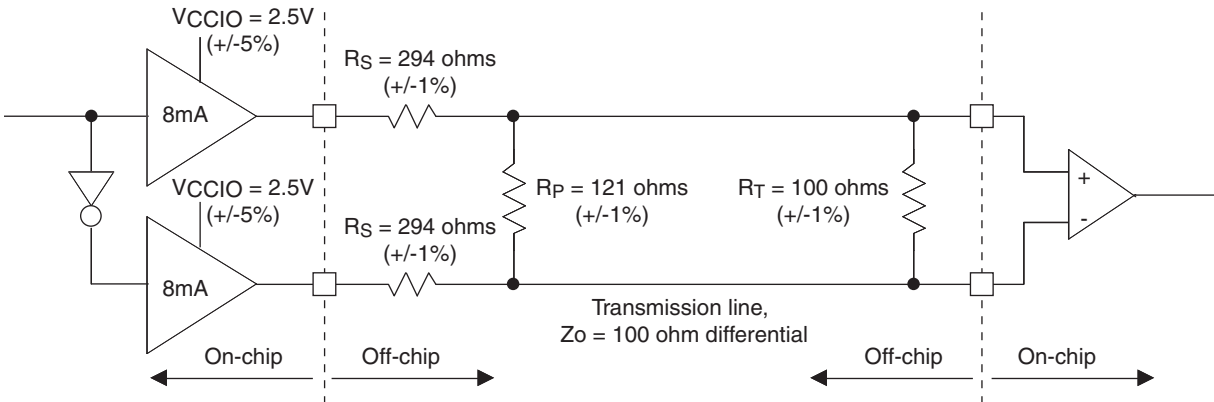

Table 3-5. RSDS DC Conditions¹

Over Recommended Operating Conditions

Parameter	Description	Typical	Units
V _{CCIO}	Output Driver Supply (+/-5%)	2.50	V
Z _{OUT}	Driver Impedance	20	Ω
R _S	Driver Series Resistor (+/-1%)	294	Ω
R _P	Driver Parallel Resistor (+/-1%)	121	Ω
R _T	Receiver Termination (+/-1%)	100	Ω
V _{OH}	Output High Voltage	1.35	V
V _{OL}	Output Low Voltage	1.15	V
V _{OD}	Output Differential Voltage	0.20	V
V _{CM}	Output Common Mode Voltage	1.25	V
Z _{BACK}	Back Impedance	101.5	Ω
I _{DC}	DC Output Current	3.66	mA

1. For input buffer, see LVDS table.

**LFE2-12E/SE and LFE2-20E/SE Logic Signal Connections: 484 fpBGA
 (Cont.)**

LFE2-12E/12SE					LFE2-20E/20SE			
Ball Number	Ball/Pad Function	Bank	Dual Function	Differential	Ball/Pad Function	Bank	Dual Function	Differential
T7	PL29B	6	LDQ28	C	PL43B	6	LDQ42	C
T6	PL26B	6	LDQ28	C (LVDS)*	PL40B	6	LDQ42	C (LVDS)*
AA2	PL31A	6	LDQ28	T	PL45A	6	LDQ42	T
VCCIO	VCCIO6	6			VCCIO6	6		
Y1	PL28A	6	LDQS28	T (LVDS)*	PL42A	6	LDQS42	T (LVDS)*
AA1	PL31B	6	LDQ28	C	PL45B	6	LDQ42	C
W1	PL28B	6	LDQ28	C (LVDS)*	PL42B	6	LDQ42	C (LVDS)*
V3	PL30B	6	LDQ28	C (LVDS)*	PL44B	6	LDQ42	C (LVDS)*
GNDIO	GNDIO6	-			GNDIO	-		
V4	PL30A	6	LDQ28	T (LVDS)*	PL44A	6	LDQ42	T (LVDS)*
U5	TDI	-			TDI	-		
U7	TCK	-			TCK	-		
V6	TDO	-			TDO	-		
V5	TMS	-			TMS	-		
T8	VCCJ	-			VCCJ	-		
W4	PB3A	5	BDQ6	T	PB3A	5	BDQ6	T
Y3	PB2A	5	VREF2_5/BDQ6	T	PB2A	5	VREF2_5/BDQ6	T
W3	PB3B	5	BDQ6	C	PB3B	5	BDQ6	C
Y2	PB2B	5	VREF1_5/BDQ6	C	PB2B	5	VREF1_5/BDQ6	C
AB3	PB5A	5	BDQ6	T	PB5A	5	BDQ6	T
VCCIO	VCCIO5	5			VCCIO5	5		
W5	PB4A	5	BDQ6	T	PB4A	5	BDQ6	T
AB2	PB5B	5	BDQ6	C	PB5B	5	BDQ6	C
W6	PB4B	5	BDQ6	C	PB4B	5	BDQ6	C
AB5	PB7A	5	BDQ6	T	PB7A	5	BDQ6	T
GNDIO	GNDIO5	-			GNDIO	-		
Y4	PB6A	5	BDQS6	T	PB6A	5	BDQS6	T
AB4	PB7B	5	BDQ6	C	PB7B	5	BDQ6	C
AA3	PB6B	5	BDQ6	C	PB6B	5	BDQ6	C
AB6	PB9A	5	BDQ6	T	PB9A	5	BDQ6	T
VCCIO	VCCIO5	5			VCCIO5	5		
AA5	PB8A	5	BDQ6	T	PB8A	5	BDQ6	T
AA6	PB9B	5	BDQ6	C	PB9B	5	BDQ6	C
Y5	PB8B	5	BDQ6	C	PB8B	5	BDQ6	C
GNDIO	GNDIO5	-			GNDIO	-		
-	-	-			VCCIO5	5		
Y6	PB12A	5	BDQ15	T	PB21A	5	BDQ24	T
W7	PB11A	5	BDQ15	T	PB20A	5	BDQ24	T
Y7	PB12B	5	BDQ15	C	PB21B	5	BDQ24	C
W8	PB11B	5	BDQ15	C	PB20B	5	BDQ24	C
U8	PB14A	5	BDQ15	T	PB23A	5	BDQ24	T
VCCIO	VCCIO5	5			VCCIO5	5		
AA7	PB13A	5	BDQ15	T	PB22A	5	BDQ24	T
U9	PB14B	5	BDQ15	C	PB23B	5	BDQ24	C

LFE2-35E/SE and LFE2-50E/SE Logic Signal Connections: 484 fpBGA
(Cont.)

LFE2-35E/SE					LFE2-50E/SE			
Ball Number	Ball/Pad Function	Bank	Dual Function	Differential	Ball/Pad Function	Bank	Dual Function	Differential
W20	CFG0	8			CFG0	8		
V20	PROGRAMN	8			PROGRAMN	8		
W22	CCLK	8			CCLK	8		
V22	INITN	8			INITN	8		
V21	DONE	8			DONE	8		
GNDIO	GNDIO8	-			GNDIO8	-		
R16	PR58B	8	WRITEN	C	PR77B	8	WRITEN	C
R17	PR58A	8	CS1N	T	PR77A	8	CS1N	T
U19	PR57B	8	CSN	C	PR76B	8	CSN	C
U20	PR57A	8	D0/SPIFASTN	T	PR76A	8	D0/SPIFASTN	T
VCCIO	VCCIO8	8			VCCIO	8		
U22	PR56B	8	D1	C	PR75B	8	D1	C
U21	PR56A	8	D2	T	PR75A	8	D2	T
T20	PR55B	8	D3	C	PR74B	8	D3	C
GNDIO	GNDIO8	-			GNDIO8	-		
T19	PR55A	8	D4	T	PR74A	8	D4	T
T17	PR54B	8	D5	C	PR73B	8	D5	C
T18	PR54A	8	D6	T	PR73A	8	D6	T
T21	PR53B	8	D7/SPID0	C	PR72B	8	D7/SPID0	C
VCCIO	VCCIO8	8			VCCIO	8		
T22	PR53A	8	DI/CSSPION	T	PR72A	8	DI/CSSPION	T
R18	PR52B	8	DOUT/CSON	C	PR71B	8	DOUT/CSON	C
R19	PR52A	8	BUSY/SISPI	T	PR71A	8	BUSY/SISPI	T
GNDIO	GNDIO3	-			GNDIO3	-		
VCCIO	VCCIO3	3			VCCIO	3		
R22	PR47B	3	RDQ48	C	PR66B	3	RDQ67	C
R21	PR47A	3	RDQ48	T	PR66A	3	RDQ67	T
P18	PR46B	3	RDQ48	C (LVDS)*	PR65B	3	RDQ67	C (LVDS)*
P19	PR46A	3	RDQ48	T (LVDS)*	PR65A	3	RDQ67	T (LVDS)*
VCCIO	VCCIO3	3			VCCIO	3		
R20	PR45B	3	RLM0_GPLL_C_FB_A/RDQ48	C	PR64B	3	RLM0_GPLL_C_FB_A/RDQ67	C
P22	PR45A	3	RLM0_GPLL_T_FB_A/RDQ48	T	PR64A	3	RLM0_GPLL_T_FB_A/RDQ67	T
P21	PR44B	3	RLM0_GPLL_C_IN_A**/RDQ48	C (LVDS)*	PR63B	3	RLM0_GPLL_C_IN_A**/RDQ67	C (LVDS)*
N21	PR44A	3	RLM0_GPLL_T_IN_A**/RDQ48	T (LVDS)*	PR63A	3	RLM0_GPLL_T_IN_A**/RDQ67	T (LVDS)*
N17	RLM0_PLLCAP	3			RLM0_PLLCAP	3		
N22	PR42B	3	RLM0_GDLL_C_FB_A/RDQ39	C	PR61B	3	RLM0_GDLL_C_FB_A/RDQ58	C
N20	PR42A	3	RLM0_GDLL_T_FB_A/RDQ39	T	PR61A	3	RLM0_GDLL_T_FB_A/RDQ58	T
GNDIO	GNDIO3	-			GNDIO3	-		
M22	PR41B	3	RLM0_GDLL_C_IN_A**/RDQ39	C (LVDS)*	PR60B	3	RLM0_GDLL_C_IN_A**/RDQ58	C (LVDS)*
M21	PR41A	3	RLM0_GDLL_T_IN_A**/RDQ39	T (LVDS)*	PR60A	3	RLM0_GDLL_T_IN_A**/RDQ58	T (LVDS)*
N19	PR40B	3	RDQ39	C	PR59B	3	RDQ58	C
M19	PR40A	3	RDQ39	T	PR59A	3	RDQ58	T
VCCIO	VCCIO3	3			VCCIO	3		
GNDIO	GNDIO3	-			GNDIO3	-		
L22	PR30B	3	RDQ31	C	PR49B	3	RDQ50	C
K22	PR30A	3	RDQ31	T	PR49A	3	RDQ50	T

**LFE2-20E/SE and LFE2-35E/SE Logic Signal Connections: 672 fpBGA
 (Cont.)**

LFE2-20E/20SE					LFE2-35E/35SE			
Ball Number	Ball/Pad Function	Bank	Dual Function	Differential	Ball/Pad Function	Bank	Dual Function	Differential
GND	GNDIO2	-			GNDIO2	-		
L21	PR18B	2	RDQ16	C (LVDS)*	PR24B	2	RDQ22	C (LVDS)*
K22	PR18A	2	RDQ16	T (LVDS)*	PR24A	2	RDQ22	T (LVDS)*
M24	PR17B	2	RDQ16	C	PR23B	2	RDQ22	C
N23	PR17A	2	RDQ16	T	PR23A	2	RDQ22	T
VCCIO	VCCIO2	2			VCCIO2	2		
K26	PR16B	2	RDQ16	C (LVDS)*	PR22B	2	RDQ22	C (LVDS)*
K25	PR16A	2	RDQS16	T (LVDS)*	PR22A	2	RDQS22	T (LVDS)*
M20	PR15B	2	RDQ16	C	PR21B	2	RDQ22	C
GND	GNDIO2	-			GNDIO2	-		
M19	PR15A	2	RDQ16	T	PR21A	2	RDQ22	T
L22	PR14B	2	RDQ16	C (LVDS)*	PR20B	2	RDQ22	C (LVDS)*
M22	PR14A	2	RDQ16	T (LVDS)*	PR20A	2	RDQ22	T (LVDS)*
K21	PR13B	2	RDQ16	C	PR19B	2	RDQ22	C
VCCIO	VCCIO2	2			VCCIO2	2		
M21	PR13A	2	RDQ16	T	PR19A	2	RDQ22	T
K24	PR12B	2	RDQ16	C (LVDS)*	PR18B	2	RDQ22	C (LVDS)*
J24	PR12A	2	RDQ16	T (LVDS)*	PR18A	2	RDQ22	T (LVDS)*
GND	GNDIO2	-			GNDIO2	-		
VCCIO	VCCIO2	2			VCCIO2	2		
L20	VCC	-			NC	-		
GND	GNDIO2	-			GNDIO2	-		
J26	NC	-			NC	-		
J25	NC	-			NC	-		
J23	NC	-			NC	-		
K23	NC	-			NC	-		
VCCIO	VCCIO2	2			VCCIO2	2		
H26	NC	-			NC	-		
H25	NC	-			NC	-		
H24	NC	-			NC	-		
GND	GNDIO2	-			GNDIO2	-		
H23	NC	-			NC	-		
VCCIO	VCCIO2	2			VCCIO2	2		
G26	PR11B	2	RDQ8	C	PR17B	2	RDQ14	C
GND	GNDIO2	-			GNDIO2	-		
G25	PR11A	2	RDQ8	T	PR17A	2	RDQ14	T
F26	PR10B	2	RDQ8	C (LVDS)*	PR16B	2	RDQ14	C (LVDS)*
F25	PR10A	2	RDQ8	T (LVDS)*	PR16A	2	RDQ14	T (LVDS)*
K20	PR9B	2	RDQ8	C	PR15B	2	RDQ14	C
VCCIO	VCCIO2	2			VCCIO2	2		
L19	PR9A	2	RDQ8	T	PR15A	2	RDQ14	T
E26	PR8B	2	RDQ8	C (LVDS)*	PR14B	2	RDQ14	C (LVDS)*
E25	PR8A	2	RDQS8	T (LVDS)*	PR14A	2	RDQS14	T (LVDS)*
GND	GNDIO2	-			GNDIO2	-		
J22	PR7B	2	RDQ8	C	PR13B	2	RDQ14	C
H22	PR7A	2	RDQ8	T	PR13A	2	RDQ14	T

LFE2M50E/SE Logic Signal Connections: 484 fpBGA (Cont.)

LFE2M50E/SE				
Ball Number	Ball/Pad Function	Bank	Dual Function	Differential
T1	PL65A	6	LLM0_GDLLT_FB_A	T
T2	PL65B	6	LLM0_GDLLC_FB_A	C
GNDIO	GNDIO6	-		
R7	LLM0_PLLCAP	6		
T6	PL67A	6	LDQ71	T (LVDS)*
T7	PL67B	6	LDQ71	C (LVDS)*
U1	PL68A	6	LDQ71	T
U2	PL68B	6	LDQ71	C
VCCIO	VCCIO6	6		
T3	PL69A	6	LDQ71	T (LVDS)*
U3	PL69B	6	LDQ71	C (LVDS)*
U6	PL70A	6	LDQ71	T
U5	PL70B	6	LDQ71	C
GNDIO	GNDIO6	-		
V5	PL71A	6	LDQS71	T (LVDS)*
U4	PL71B	6	LDQ71	C (LVDS)*
V1	PL72A	6	LDQ71	T
VCCIO	VCCIO6	6		
V3	PL72B	6	LDQ71	C
W1	PL73A	6	LDQ71	T (LVDS)*
Y1	PL73B	6	LDQ71	C (LVDS)*
AA1	PL74A	6	LDQ71	T
GNDIO	GNDIO6	-		
AA2	PL74B	6	LDQ71	C
V4	TCK	-		
Y2	TDI	-		
Y3	TMS	-		
W3	TDO	-		
W4	VCCJ	-		
W5	PB2A	5	BDQ6	T
Y4	PB2B	5	BDQ6	C
W6	PB3A	5	BDQ6	T
V6	PB3B	5	BDQ6	C
AA3	PB4A	5	BDQ6	T
AB2	PB4B	5	BDQ6	C
VCCIO	VCCIO5	5		
T8	PB5A	5	BDQ6	T
U7	PB5B	5	BDQ6	C
GNDIO	GNDIO5	-		
U8	PB6A	5	BDQS6	T
T9	PB6B	5	BDQ6	C
V8	PB7A	5	BDQ6	T
W8	PB7B	5	BDQ6	C

LFE2M50E/SE Logic Signal Connections: 484 fpBGA (Cont.)

LFE2M50E/SE				
Ball Number	Ball/Pad Function	Bank	Dual Function	Differential
U12	PB59B	4	BDQ60	C
GNDIO	GNDIO4	-		
AA12	PB60A	4	BDQS60	T
Y12	PB60B	4	BDQ60	C
V12	PB61A	4	BDQ60	T
W12	PB61B	4	BDQ60	C
AB12	PB62A	4	BDQ60	T
AA13	PB62B	4	BDQ60	C
VCCIO	VCCIO4	4		
T12	PB63A	4	BDQ60	T
U13	PB63B	4	BDQ60	C
V13	PB64A	4	BDQ60	T
T13	PB64B	4	BDQ60	C
GNDIO	GNDIO4	-		
AB13	PB65A	4	BDQ69	T
AB14	PB65B	4	BDQ69	C
U14	PB66A	4	BDQ69	T
T14	PB66B	4	BDQ69	C
AA14	PB67A	4	BDQ69	T
VCCIO	VCCIO4	4		
Y14	PB67B	4	BDQ69	C
W14	PB68A	4	BDQ69	T
V14	PB68B	4	BDQ69	C
AB15	PB69A	4	BDQS69	T
GNDIO	GNDIO4	-		
AA15	PB69B	4	BDQ69	C
V15	PB70A	4	BDQ69	T
U15	PB70B	4	BDQ69	C
AB16	PB71A	4	BDQ69	T
VCCIO	VCCIO4	4		
AA16	PB71B	4	BDQ69	C
AB17	PB72A	4	BDQ69	T
AA17	PB72B	4	BDQ69	C
GNDIO	GNDIO4	-		
W20	CFG2	8		
V20	CFG1	8		
V19	CFG0	8		
V22	PROGRAMN	8		
W22	CCLK	8		
U18	INITN	8		
U22	DONE	8		
GNDIO	GNDIO8	-		
U20	WRITEN***	8		

LFE2M50E/SE Logic Signal Connections: 484 fpBGA (Cont.)

LFE2M50E/SE				
Ball Number	Ball/Pad Function	Bank	Dual Function	Differential
F20	PR30A	2	RDQ27	T
GNDIO	GNDIO2	-		
G17	PR29B	2	RDQ27	C (LVDS)*
F17	PR29A	2	RDQ27	T (LVDS)*
VCCIO	VCCIO2	2		
GNDIO	GNDIO2	-		
E22	PR14B	2		C
D22	PR14A	2		T
VCCIO	VCCIO2	-		
E20	PR13B	2		C (LVDS)*
D20	PR13A	2		T (LVDS)*
D19	PR12B	2	RUM0_SPLLC_FB_A	C
GNDIO	GNDIO2	-		
E19	PR12A	2	RUM0_SPLLT_FB_A	T
F18	PR11B	2	RUM0_SPLLC_IN_A	C (LVDS)*
F19	PR11A	2	RUM0_SPLLT_IN_A	T (LVDS)*
VCCIO	VCCIO2	-		
E18	PR9B	2	VREF2_2	C
GNDIO	GNDIO2	-		
D18	PR9A	2	VREF1_2	T
VCCIO	VCCIO2	2		
F16	XRES	-		
C22	URC_SQ_VCCR0	12		
A21	URC_SQ_HDINP0	12		T
B22	URC_SQ_VCCIB0	12		
B21	URC_SQ_HDINN0	12		C
C19	URC_SQ_VCCTX0	12		
A18	URC_SQ_HDOUTP0	12		T
A19	URC_SQ_VCCOB0	12		
B18	URC_SQ_HDOUTN0	12		C
C18	URC_SQ_VCCTX1	12		
B17	URC_SQ_HDOUTN1	12		C
C17	URC_SQ_VCCOB1	12		
A17	URC_SQ_HDOUTP1	12		T
C21	URC_SQ_VCCR1	12		
B20	URC_SQ_HDINN1	12		C
C20	URC_SQ_VCCIB1	12		
A20	URC_SQ_HDINP1	12		T
B16	URC_SQ_VCCAUX33	12		
E17	URC_SQ_REFCLKN	12		C
D17	URC_SQ_REFCLKP	12		T
C16	URC_SQ_VCCP	12		
A12	URC_SQ_HDINP2	12		T

**LFE2M35E/SE and LFE2M50E/SE Logic Signal Connections: 672 fpBGA
 (Cont.)**

LFE2M35E/SE					LFE2M50E/SE				
Ball Number	Ball/Pad Function	Bank	Dual Function	Differential	Ball/Pad Function	Bank	Dual Function	Differential	
AA14	PB42B	4	BDQ42	C	PB51B	4	BDQ51	C	
VCCIO	VCCIO4	4			VCCIO4	4			
GNDIO	GNDIO4	-			GNDIO4	-			
W17	PB65A	4	BDQ69	T	PB56A	4	BDQ60	T	
AA19	PB65B	4	BDQ69	C	PB56B	4	BDQ60	C	
AC15	PB48A	4	BDQ51	T	PB57A	4	BDQ60	T	
Y18	PB68B	4	BDQ69	C	PB57B	4	BDQ60	C	
AB15	PB49A	4	BDQ51	T	PB58A	4	BDQ60	T	
AC16	PB49B	4	BDQ51	C	PB58B	4	BDQ60	C	
VCCIO	VCCIO4	4			VCCIO4	4			
AA17	PB60A	4	BDQS60****	T	PB59A	4	BDQ60	T	
AB16	PB50B	4	BDQ51	C	PB59B	4	BDQ60	C	
GNDIO	GNDIO4	-			GNDIO4	-			
AA15	PB51A	4	BDQS51****	T	PB60A	4	BDQS60	T	
W16	PB59B	4	BDQ60	C	PB60B	4	BDQ60	C	
Y15	PB52A	4	BDQ51	T	PB61A	4	BDQ60	T	
AC17	PB52B	4	BDQ51	C	PB61B	4	BDQ60	C	
AA18	PB61A	4	BDQ60	T	PB62A	4	BDQ60	T	
Y17	PB61B	4	BDQ60	C	PB62B	4	BDQ60	C	
-	-	-			VCCIO4	4			
GNDIO	GNDIO4	-			-	-			
W15	PB54A	4	BDQ51	T	PB63A	4	BDQ60	T	
AB17	PB54B	4	BDQ51	C	PB63B	4	BDQ60	C	
GNDIO	GNDIO4	-			GNDIO4	-			
VCCIO	VCCIO4	4			VCCIO4	4			
V17	PB73A	4	BDQ69	T	PB72A	4	BDQ69	T	
AA20	PB73B	4	BDQ69	C	PB72B	4	BDQ69	C	
GNDIO	GNDIO4	-			GNDIO4	-			
AD13	VCC	-			LRC_SQ_VCCRX3	13			
AF14	PB47A	4	BDQ51	T	LRC_SQ_HDINP3	13		T	
AE13	NC	-			LRC_SQ_VCCIB3	13			
AE14	PB41A	4	VREF2_4/BDQ42	T	LRC_SQ_HDINN3	13		C	
AD16	VCC	-			LRC_SQ_VCCTX3	13			
AF17	PB51B	4	BDQ51	C	LRC_SQ_HDOUTP3	13		T	
AF16	NC	-			LRC_SQ_VCCOB3	13			
AE17	PB50A	4	BDQ51	T	LRC_SQ_HDOUTN3	13		C	
AD17	VCC	-			LRC_SQ_VCCTX2	13			
AE18	PB53B	4	BDQ51	C	LRC_SQ_HDOUTN2	13		C	
AD18	NC	-			LRC_SQ_VCCOB2	13			
AF18	PB53A	4	BDQ51	T	LRC_SQ_HDOUTP2	13		T	
AD14	VCC	-			LRC_SQ_VCCRX2	13			
AE15	PB48B	4	BDQ51	C	LRC_SQ_HDINN2	13		C	
AD15	NC	-			LRC_SQ_VCCIB2	13			
AF15	PB47B	4	BDQ51	C	LRC_SQ_HDINP2	13		T	
AD19	VCC	-			LRC_SQ_VCCP	13			
AC19	PB57B	4	BDQ60	C	LRC_SQ_REFCLKP	13		T	
AB19	PB59A	4	BDQ60	T	LRC_SQ_REFCLKN	13		C	
AE19	VCCAUX	-			LRC_SQ_VCCAUX33	13			

**LFE2M35E/SE and LFE2M50E/SE Logic Signal Connections: 672 fpBGA
 (Cont.)**

LFE2M35E/SE					LFE2M50E/SE				
Ball Number	Ball/Pad Function	Bank	Dual Function	Differential	Ball/Pad Function	Bank	Dual Function	Differential	
T18	VCCAUX	-			VCCAUX	-			
T9	VCCAUX	-			VCCAUX	-			
V11	VCCAUX	-			VCCAUX	-			
V12	VCCAUX	-			VCCAUX	-			
V15	VCCAUX	-			VCCAUX	-			
V16	VCCAUX	-			VCCAUX	-			
A13	GND	-			GND	-			
A19	GND	-			GND	-			
A2	GND	-			GND	-			
A25	GND	-			GND	-			
AA2	GND	-			GND	-			
AA25	GND	-			GND	-			
AB18	GND	-			GND	-			
AB22	GND	-			GND	-			
AB5	GND	-			GND	-			
AB9	GND	-			GND	-			
AE1	GND	-			GND	-			
AE11	GND	-			GND	-			
AE16	GND	-			GND	-			
AE22	GND	-			GND	-			
AE26	GND	-			GND	-			
AE6	GND	-			GND	-			
AF13	GND	-			GND	-			
AF19	GND	-			GND	-			
AF2	GND	-			GND	-			
AF25	GND	-			GND	-			
B1	GND	-			GND	-			
B11	GND	-			GND	-			
B16	GND	-			GND	-			
B22	GND	-			GND	-			
B26	GND	-			GND	-			
B6	GND	-			GND	-			
E18	GND	-			GND	-			
E22	GND	-			GND	-			
E5	GND	-			GND	-			
E9	GND	-			GND	-			
F2	GND	-			GND	-			
F25	GND	-			GND	-			
G11	GND	-			GND	-			
G16	GND	-			GND	-			
J22	GND	-			GND	-			
J5	GND	-			GND	-			
K11	GND	-			GND	-			
K13	GND	-			GND	-			
K14	GND	-			GND	-			
K16	GND	-			GND	-			
L10	GND	-			GND	-			
L11	GND	-			GND	-			

LFE2M50E/SE and LFE2M70E/SE Logic Signal Connections: 900 fpBGA
(Cont.)

LFE2M50E/SE					LFE2M70E/SE				
Ball Number	Ball/Pad Function	Bank	Dual Function	Differential	Ball/Pad Function	Bank	Dual Function	Differential	
AJ17	PB62B	4	BDQ60	C	PB71B	4	BDQ69	C	
VCCIO	VCCIO4	4			VCCIO4	4			
AF26	PB64A	4	BDQ60	T	PB73A	4	BDQ69	T	
AE25	PB64B	4	BDQ60	C	PB73B	4	BDQ69	C	
GNDIO	GNDIO4	-			GNDIO4	-			
AD24	PB65A	4	BDQ69	T	PB74A	4	BDQ78	T	
AE24	PB65B	4	BDQ69	C	PB74B	4	BDQ78	C	
AD18	PB66A	4	BDQ69	T	PB75A	4	BDQ78	T	
AC18	PB66B	4	BDQ69	C	PB75B	4	BDQ78	C	
AE18	PB67A	4	BDQ69	T	PB76A	4	BDQ78	T	
AG19	PB67B	4	BDQ69	C	PB76B	4	BDQ78	C	
VCCIO	VCCIO4	4			VCCIO4	4			
GNDIO	GNDIO4	-			GNDIO4	-			
AC19	PB69A	4	BDQS69	T	PB78A	4	BDQS78	T	
AD20	PB69B	4	BDQ69	C	PB78B	4	BDQ78	C	
AB18	PB70A	4	BDQ69	T	PB79A	4	BDQ78	T	
AC20	PB70B	4	BDQ69	C	PB79B	4	BDQ78	C	
AE20	PB71A	4	BDQ69	T	PB80A	4	BDQ78	T	
AE21	PB71B	4	BDQ69	C	PB80B	4	BDQ78	C	
VCCIO	VCCIO4	4			VCCIO4	4			
AC23	PB72A	4	BDQ69	T	PB81A	4	BDQ78	T	
AD23	PB72B	4	BDQ69	C	PB81B	4	BDQ78	C	
GNDIO	GNDIO4	-			GNDIO4	-			
AH18	LRC_SQ_VCCR3	13			LRC_SQ_VCCR3	13			
AK19	LRC_SQ_HDINP3	13		T	LRC_SQ_HDINP3	13		T	
AJ18	LRC_SQ_VCCIB3	13			LRC_SQ_VCCIB3	13			
AJ19	LRC_SQ_HDINN3	13		C	LRC_SQ_HDINN3	13		C	
AH21	LRC_SQ_VCCTX3	13			LRC_SQ_VCCTX3	13			
AK22	LRC_SQ_HDOUTP3	13		T	LRC_SQ_HDOUTP3	13		T	
AK21	LRC_SQ_VCCOB3	13			LRC_SQ_VCCOB3	13			
AJ22	LRC_SQ_HDOUTN3	13		C	LRC_SQ_HDOUTN3	13		C	
AH22	LRC_SQ_VCCTX2	13			LRC_SQ_VCCTX2	13			
AJ23	LRC_SQ_HDOUTN2	13		C	LRC_SQ_HDOUTN2	13		C	
AH23	LRC_SQ_VCCOB2	13			LRC_SQ_VCCOB2	13			
AK23	LRC_SQ_HDOUTP2	13		T	LRC_SQ_HDOUTP2	13		T	
AH19	LRC_SQ_VCCR2	13			LRC_SQ_VCCR2	13			
AJ20	LRC_SQ_HDINN2	13		C	LRC_SQ_HDINN2	13		C	
AH20	LRC_SQ_VCCIB2	13			LRC_SQ_VCCIB2	13			
AK20	LRC_SQ_HDINP2	13		T	LRC_SQ_HDINP2	13		T	
AH24	LRC_SQ_VCCP	13			LRC_SQ_VCCP	13			
AG24	LRC_SQ_REFCLKP	13		T	LRC_SQ_REFCLKP	13		T	
AF24	LRC_SQ_REFCLKN	13		C	LRC_SQ_REFCLKN	13		C	
AJ24	LRC_SQ_VCCAUX33	13			LRC_SQ_VCCAUX33	13			
AK28	LRC_SQ_HDINP1	13		T	LRC_SQ_HDINP1	13		T	
AH28	LRC_SQ_VCCIB1	13			LRC_SQ_VCCIB1	13			
AJ28	LRC_SQ_HDINN1	13		C	LRC_SQ_HDINN1	13		C	
AH29	LRC_SQ_VCCR1	13			LRC_SQ_VCCR1	13			
AK25	LRC_SQ_HDOUTP1	13		T	LRC_SQ_HDOUTP1	13		T	

LFE2M100E/SE Logic Signal Connections: 900 fpBGA (Cont.)

LFE2M100E/SE				
Ball Number	Ball/Pad Function	Bank	Dual Function	Differential
K26	PR26A	2	RDQ23	T
K23	PR25B	2	RDQ23	C (LVDS)*
K22	PR25A	2	RDQ23	T (LVDS)*
J22	PR24B	2	RDQ23	C
VCCIO	VCCIO2	2		
J23	PR24A	2	RDQ23	T
GNDIO	GNDIO2	-		
VCCIO	VCCIO2	2		
J26	PR17B	2	RDQ15	C (LVDS)*
H26	PR17A	2	RDQ15	T (LVDS)*
H27	PR16B	2	RDQ15	C
G26	PR16A	2	RDQ15	T
VCCIO	VCCIO2	2		
H23	PR15B	2	RDQ15	C (LVDS)*
H24	PR15A	2	RDQS15	T (LVDS)*
D28	PR14B	2	RDQ15	C
GNDIO	GNDIO2	-		
E28	PR14A	2	RDQ15	T
G24	PR13B	2	RDQ15	C (LVDS)*
H25	PR13A	2	RDQ15	T (LVDS)*
D27	PR12B	2	RUM0_SPLLC_FB_A/RDQ15	C
VCCIO	VCCIO2	2		
E27	PR12A	2	RUM0_SPLLT_FB_A/RDQ15	T
F26	PR11B	2	RUM0_SPLLC_IN_A/RDQ15	C (LVDS)*
G25	PR11A	2	RUM0_SPLLT_IN_A/RDQ15	T (LVDS)*
F24	PR9B	2	VREF2_2	C
-	-	-		
GNDIO	GNDIO2	-		
F25	PR9A	2	VREF1_2	T
VCCIO	VCCIO2	2		
G23	XRES	1		
C30	URC_SQ_VCCR0	12		
A29	URC_SQ_HDINP0	12		T
B30	URC_SQ_VCCIB0	12		
B29	URC_SQ_HDINN0	12		C
C27	URC_SQ_VCCTX0	12		
A26	URC_SQ_HDOUTP0	12		T
A27	URC_SQ_VCCOB0	12		
B26	URC_SQ_HDOUTN0	12		C
C26	URC_SQ_VCCTX1	12		
B25	URC_SQ_HDOUTN1	12		C
C25	URC_SQ_VCCOB1	12		
A25	URC_SQ_HDOUTP1	12		T

LFE2M100E/SE Logic Signal Connections: 900 fpBGA (Cont.)

LFE2M100E/SE				
Ball Number	Ball/Pad Function	Bank	Dual Function	Differential
D19	PT93B	1		C
E18	PT93A	1		T
D18	PT92B	1		C
C17	PT92A	1		T
A17	PT91B	1		C
B17	PT91A	1		T
GNDIO	GNDIO1	-		
VCCIO	VCCIO1	1		
J18	PT75B	1		C
J19	PT75A	1		T
H17	PT74B	1		C
J17	PT74A	1		T
F18	PT73B	1		C
F17	PT73A	1		T
GNDIO	GNDIO1	-		
A16	PT72B	1		C
B16	PT72A	1		T
G17	PT71B	1		C
G16	PT71A	1		T
VCCIO	VCCIO1	1		
H16	PT70B	1		C
F16	PT70A	1		T
J16	PT69B	1		C
G15	PT69A	1		T
GNDIO	GNDIO1	-		
C16	PT68B	1		C
D16	PT68A	1		T
J15	PT67B	1		C
H15	PT67A	1		T
VCCIO	VCCIO1	1		
A15	PT66B	1	VREF2_1	C
B15	PT66A	1	VREF1_1	T
F15	PT65B	1	PCLKC1_0	C
E16	PT65A	1	PCLKT1_0	T
C15	PT64B	0	PCLKC0_0	C
GNDIO	GNDIO0	-		
D15	PT64A	0	PCLKT0_0	T
C14	PT63B	0	VREF2_0	C
E15	PT63A	0	VREF1_0	T
G14	PT62B	0		C
VCCIO	VCCIO0	0		
J14	PT62A	0		T
F14	PT61B	0		C

LFE2M100E/SE Logic Signal Connections: 900 fpBGA (Cont.)

LFE2M100E/SE				
Ball Number	Ball/Pad Function	Bank	Dual Function	Differential
AE27	GND	-		
AE4	GND	-		
AE9	GND	-		
AF14	GND	-		
AF17	GND	-		
AF25	GND	-		
AF6	GND	-		
AJ10	GND	-		
AJ21	GND	-		
AJ27	GND	-		
AJ4	GND	-		
AK1	GND	-		
AK13	GND	-		
AK18	GND	-		
AK24	GND	-		
AK30	GND	-		
AK7	GND	-		
B10	GND	-		
B21	GND	-		
B27	GND	-		
B4	GND	-		
D25	GND	-		
D6	GND	-		
E14	GND	-		
E17	GND	-		
F22	GND	-		
F27	GND	-		
F4	GND	-		
F9	GND	-		
G12	GND	-		
G19	GND	-		
J24	GND	-		
J7	GND	-		
K14	GND	-		
K15	GND	-		
K16	GND	-		
K17	GND	-		
K27	GND	-		
K4	GND	-		
L14	GND	-		
L15	GND	-		
L16	GND	-		
L17	GND	-		

LatticeECP2 S-Series Devices, Conventional Packaging
Commercial

Part Number	I/Os	Voltage	Grade	Package	Pins	Temp.	LUTs (K)
LFE2-6SE-5T144C	90	1.2V	-5	TQFP	144	Com	6
LFE2-6SE-6T144C	90	1.2V	-6	TQFP	144	Com	6
LFE2-6SE-7T144C	90	1.2V	-7	TQFP	144	Com	6
LFE2-6SE-5F256C	190	1.2V	-5	fpBGA	256	Com	6
LFE2-6SE-6F256C	190	1.2V	-6	fpBGA	256	Com	6
LFE2-6SE-7F256C	190	1.2V	-7	fpBGA	256	Com	6

Part Number	I/Os	Voltage	Grade	Package	Pins	Temp.	LUTs (K)
LFE2-12SE-5T144C	93	1.2V	-5	TQFP	144	Com	12
LFE2-12SE-6T144C	93	1.2V	-6	TQFP	144	Com	12
LFE2-12SE-7T144C	93	1.2V	-7	TQFP	144	Com	12
LFE2-12SE-5Q208C	131	1.2V	-5	PQFP	208	Com	12
LFE2-12SE-6Q208C	131	1.2V	-6	PQFP	208	Com	12
LFE2-12SE-7Q208C	131	1.2V	-7	PQFP	208	Com	12
LFE2-12SE-5F256C	193	1.2V	-5	fpBGA	256	Com	12
LFE2-12SE-6F256C	193	1.2V	-6	fpBGA	256	Com	12
LFE2-12SE-7F256C	193	1.2V	-7	fpBGA	256	Com	12
LFE2-12SE-5F484C	297	1.2V	-5	fpBGA	484	Com	12
LFE2-12SE-6F484C	297	1.2V	-6	fpBGA	484	Com	12
LFE2-12SE-7F484C	297	1.2V	-7	fpBGA	484	Com	12

Part Number	I/Os	Voltage	Grade	Package	Pins	Temp.	LUTs (K)
LFE2-20SE-5Q208C	131	1.2V	-5	PQFP	208	Com	20
LFE2-20SE-6Q208C	131	1.2V	-6	PQFP	208	Com	20
LFE2-20SE-7Q208C	131	1.2V	-7	PQFP	208	Com	20
LFE2-20SE-5F256C	193	1.2V	-5	fpBGA	256	Com	20
LFE2-20SE-6F256C	193	1.2V	-6	fpBGA	256	Com	20
LFE2-20SE-7F256C	193	1.2V	-7	fpBGA	256	Com	20
LFE2-20SE-5F484C	331	1.2V	-5	fpBGA	484	Com	20
LFE2-20SE-6F484C	331	1.2V	-6	fpBGA	484	Com	20
LFE2-20SE-7F484C	331	1.2V	-7	fpBGA	484	Com	20
LFE2-20SE-5F672C	402	1.2V	-5	fpBGA	672	Com	20
LFE2-20SE-6F672C	402	1.2V	-6	fpBGA	672	Com	20
LFE2-20SE-7F672C	402	1.2V	-7	fpBGA	672	Com	20

Part Number	I/Os	Voltage	Grade	Package	Pins	Temp.	LUTs (K)
LFE2M100SE-5FN1152C	520	1.2V	-5	Lead-Free fpBGA	1152	Com	100
LFE2M100SE-6FN1152C	520	1.2V	-6	Lead-Free fpBGA	1152	Com	100
LFE2M100SE-7FN1152C	520	1.2V	-7	Lead-Free fpBGA	1152	Com	100
LFE2M100SE-5FN900C	416	1.2V	-5	Lead-Free fpBGA	900	Com	100
LFE2M100SE-6FN900C	416	1.2V	-6	Lead-Free fpBGA	900	Com	100
LFE2M100SE-7FN900C	416	1.2V	-7	Lead-Free fpBGA	900	Com	100