

Welcome to [E-XFL.COM](http://E-XFL.COM)

## Understanding [Embedded - CPLDs \(Complex Programmable Logic Devices\)](#)

Embedded - CPLDs, or Complex Programmable Logic Devices, are highly versatile digital logic devices used in electronic systems. These programmable components are designed to perform complex logical operations and can be customized for specific applications. Unlike fixed-function ICs, CPLDs offer the flexibility to reprogram their configuration, making them an ideal choice for various embedded systems. They consist of a set of logic gates and programmable interconnects, allowing designers to implement complex logic circuits without needing custom hardware.

## Applications of Embedded - CPLDs

### Details

Product Status	Obsolete
Programmable Type	In System Programmable
Delay Time tpd(1) Max	4 ns
Voltage Supply - Internal	3V ~ 3.6V
Number of Logic Elements/Blocks	8
Number of Macrocells	256
Number of Gates	-
Number of I/O	141
Operating Temperature	0°C ~ 90°C (TJ)
Mounting Type	Surface Mount
Package / Case	256-BGA
Supplier Device Package	256-FPBGA (17x17)
Purchase URL	<a href="https://www.e-xfl.com/product-detail/lattice-semiconductor/lc5256mv-4fn256c">https://www.e-xfl.com/product-detail/lattice-semiconductor/lc5256mv-4fn256c</a>



Product Line	Ordering Part Number	Product Status	Reference PCN
LC5512MC (Cont'd)	LC5512MC-45F484C	Discontinued	<a href="#">PCN#09-10</a>
	LC5512MC-45FN484C		
	LC5512MC-75F484C		
	LC5512MC-75FN484C		
	LC5512MC-75F484I		
	LC5512MC-75FN484I		
LC5768MV	LC5768MV-5F256C	Active / Orderable	
	LC5768MV-5FN256C		
	LC5768MV-75F256C		
	LC5768MV-75FN256C		
	LC5768MV-75F256I		
	LC5768MV-75FN256I		
	LC5768MV-5F484C		
	LC5768MV-5FN484C		
	LC5768MV-75F484C		
	LC5768MV-75FN484C		
	LC5768MV-75F484I		
	LC5768MV-75FN484I		
	LC5768MB		
LC5768MB-5FN256C			
LC5768MB-75F256C			
LC5768MB-75FN256C			
LC5768MB-75F256I			
LC5768MB-75FN256I			
LC5768MB-5F484C			
LC5768MB-5FN484C			
LC5768MB-75F484C			
LC5768MB-75FN484C			
LC5768MB-75F484I			
LC5768MB-75FN484I			
LC5768MC		LC5768MC-5F256C	Discontinued
	LC5768MC-5FN256C		
	LC5768MC-75F256C		
	LC5768MC-75FN256C		
	LC5768MC-75F256I		
	LC5768MC-75FN256I		
	LC5768MC-5F484C		
	LC5768MC-5FN484C		
	LC5768MC-75F484C		
	LC5768MC-75FN484C		
	LC5768MC-75F484I		
	LC5768MC-75FN484I		

### Pseudo Dual-Port SRAM Mode

In Pseudo Dual-Port SRAM Mode the multi-function array is configured as a SRAM with an independent read and write ports that access the same 16,384-bits of memory. Data widths of 1, 2, 4, 8, 16 and 32 are supported by the MFB. Figure 10 shows the block diagram of the Pseudo Dual-Port SRAM.

Write data, write address, chip select and write enable signals are always synchronous (registered). The read data and read address signals can be synchronous or asynchronous. Reset is asynchronous. All write signals share the same clock, and clock enable. All read signals share the same clock and clock enable. Reset is shared by both read and write signals. Table 6 shows the possible sources for the clock, clock enable and initialization signals for the various registers.

Figure 10. Pseudo Dual-Port SRAM Block Diagram

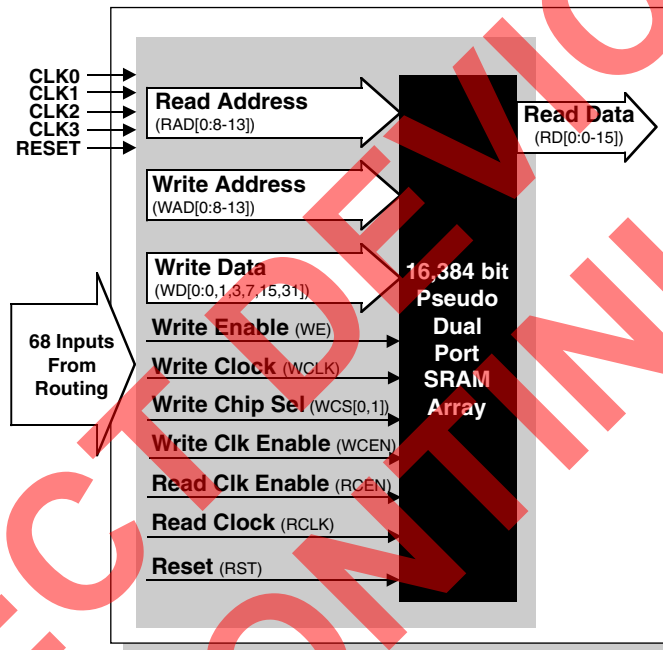

Table 6. Register Clock, Clock Enable, and Reset in Pseudo Dual-Port SRAM Mode

Register	Input	Source
Write Address, Write Data, Write Enable, and Write Chip Select	Clock	WCLK or one of the global clocks (CLK0 - CLK3). The selected signal can be inverted if desired.
	Clock Enable	WCEN or one of the global clocks (CLK1 - CLK2). The selected signal can be inverted if desired.
	Reset	Created by the logical OR of the global reset signal and RST. RST may have inversion if desired.
Read Data and Read Address	Clock	RCLK or one of the global clocks (CLK0 - CLK3). The selected signal can be inverted if desired.
	Clock Enable	RCEN or one of the global clocks (CLK1 - CLK2). The selected signal can be inverted if desired.
	Reset	Created by the logical OR of the global reset signal and RST. RST may have inversion if desired.

Figure 15. PLL Block Diagram

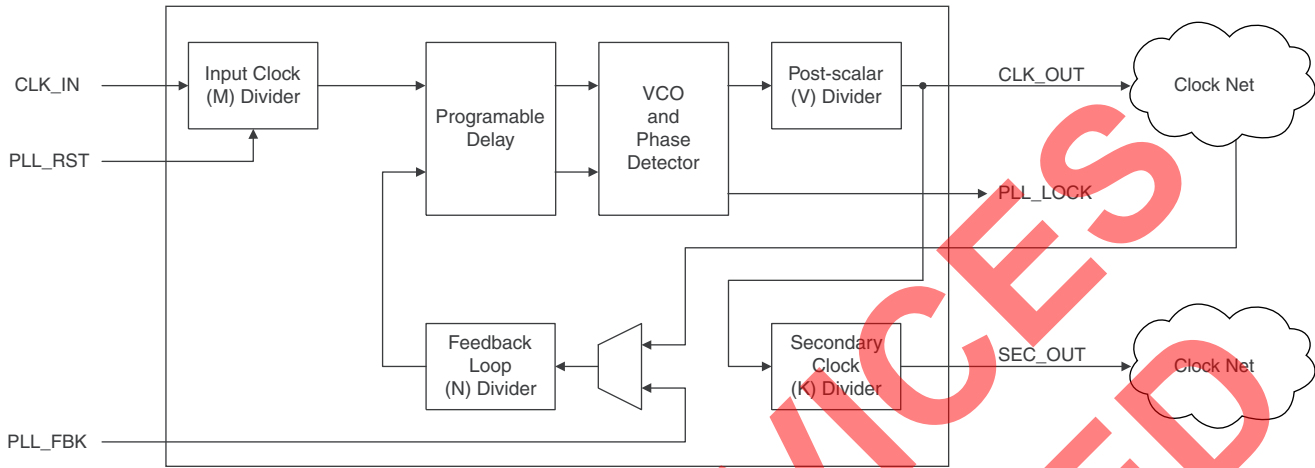
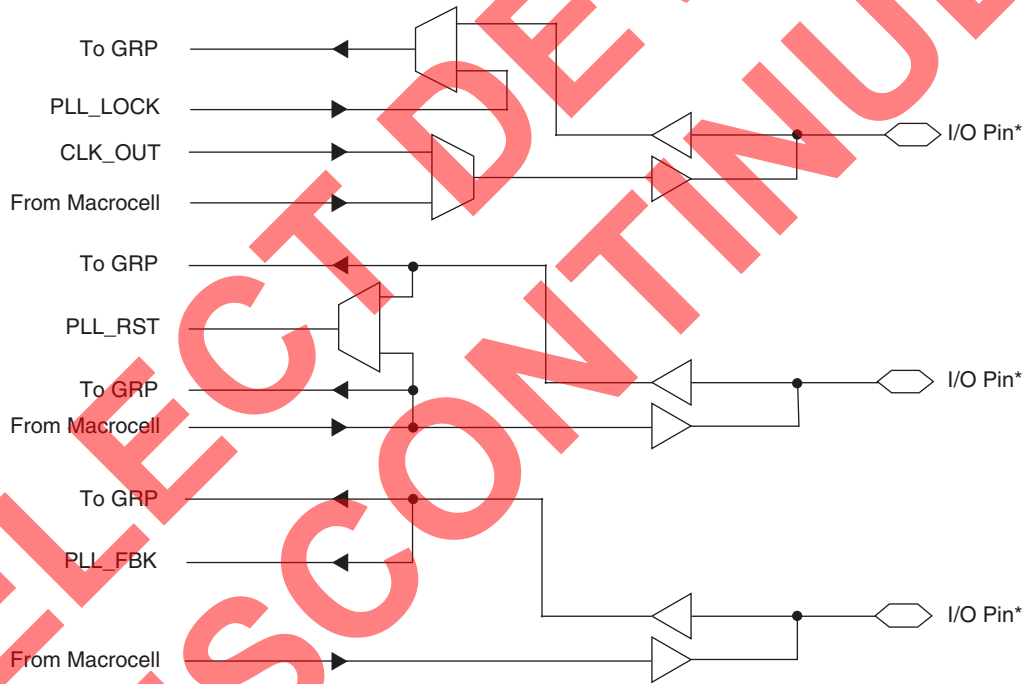

Figure 16. Connection of Optional PLL Inputs and Outputs



\*See pinout table for details

In order to facilitate the multiply and divide capabilities of the PLL, each PLL has dividers associated with it: M, N and K. The M divider is used to divide the clock signal, while the N divider is used to multiply the clock signal. The K divider is only used when a secondary clock output is needed. This divider divides the primary clock output and feeds to a separate global clock net. The V divider is used to provide lower frequency output clocks, while maintaining a stable, high frequency output from the PLL's VCO circuit. The PLL also has a delay feature that allows the output clock to be advanced or delayed to improve set-up and clock-to-out times for better performance. For more information on the PLL, please refer to TN1003, [sysCLOCK PLL Usage Guide for ispXPGA, ispGDX2, ispXPLD and ispMACH 5000VG Devices](#).

## ispXPLD 5000MX Family Internal Switching Characteristics (Continued)

Over Recommended Operating Conditions

Parameter	Description	Base Parameter	-4		-45		-5		-52		-75		Units
			Min.	Max.	Min.	Max.	Min.	Max.	Min.	Max.	Min.	Max.	
$t_{DPCEBS}$	Clock Enable B Setup before Clock B Time	—	2.33	—	2.33	—	2.33	—	2.33	—	3.03	—	ns
$t_{DPCEBH}$	Clock Enable Hold B after Clock B Time	—	-2.95	—	-2.95	—	-2.95	—	-2.95	—	-2.27	—	ns
$t_{DPADDBS}$	Address B Setup before Clock B Time	—	-0.27	—	-0.27	—	-0.27	—	-0.27	—	-0.21	—	ns
$t_{DPADDBH}$	Address B Hold time after Clock B Time	—	-0.01	—	-0.01	—	-0.01	—	-0.01	—	-0.01	—	ns
$t_{DPRWBS}$	R/W B Setup before Clock B Time	—	-0.27	—	-0.27	—	-0.27	—	-0.27	—	-0.21	—	ns
$t_{DPRWBH}$	R/W B Hold time after Clock B Time	—	-0.01	—	-0.01	—	-0.01	—	-0.01	—	-0.01	—	ns
$t_{DPDATABS}$	Write Data B Setup before Clock B Time	—	-0.27	—	-0.27	—	-0.27	—	-0.27	—	-0.21	—	ns
$t_{DPDATABH}$	Write Data B Hold after Clock B Time	—	-0.01	—	-0.01	—	-0.01	—	-0.01	—	-0.01	—	ns
$t_{DPRCLKAO}$	Read Clock A to Output Delay	—	—	5.97	—	5.92	—	5.86	—	5.65	—	9.86	ns
$t_{DPRCLKBO}$	Read Clock B to Output Delay	—	—	5.16	—	5.16	—	5.16	—	5.16	—	6.71	ns
$t_{DPCLKSKEW}$	Opposite Clock Cycle Delay	—	1.40	—	1.40	—	1.40	—	1.40	—	1.83	—	ns
$t_{DPRSTO}$	Reset to RAM Output Delay	—	—	3.30	—	3.30	—	3.30	—	3.30	—	4.29	ns
$t_{DPRSTR}$	Reset Recovery Time	—	1.20	—	1.20	—	1.20	—	1.20	—	1.56	—	ns
$t_{DPRSTPW}$	Reset Pulse Width	—	0.14	—	0.14	—	0.14	—	0.14	—	0.19	—	ns

Timing v.1.8

1. The PT-delay to clock of RAM/FIFO/CAM should be  $t_{BCLK}$  instead of  $t_{PTCLK}$ .
2. The PT-delay to set/reset of RAM/FIFO/CAM should be  $t_{BSR}$  instead of  $t_{PTSR}$ .

## Boundary Scan Timing Specifications

Over Recommended Operating Conditions

Parameter	Description	Min	Max	Units
$t_{BTCP}$	TCK [BSCAN] clock pulse width	40	—	ns
$t_{BTCPH}$	TCK [BSCAN] clock pulse width high	20	—	ns
$t_{BTCPL}$	TCK [BSCAN] clock pulse width low	20	—	ns
$t_{BTS}$	TCK [BSCAN] setup time	8	—	ns
$t_{BTH}$	TCK [BSCAN] hold time	10	—	ns
$t_{BTRF}$	TCK [BSCAN] rise/fall time	50	—	mV/ns
$t_{BTCO}$	TAP controller falling edge of clock to valid output	—	10	ns
$t_{BTCODIS}$	TAP controller falling edge of clock to valid disable	—	10	ns
$t_{BTCOEN}$	TAP controller falling edge of clock to valid enable	—	10	ns
$t_{BTCRS}$	BSCAN test capture register setup time	8	—	ns
$t_{BTCRH}$	BSCAN test capture register hold time	10	—	ns
$t_{BUTCO}$	BSCAN test update register, falling edge of clock to valid output	—	25	ns
$t_{BTUODIS}$	BSCAN test update register, falling edge of clock to valid disable	—	25	ns
$t_{BTUPOEN}$	BSCAN test update register, falling edge of clock to valid enable	—	25	ns

SELECT DEVICES  
DISCONTINUED

## Power Estimation Equations

$$ICC = ICC\_DC + IMFB\_CPLD + IMFB\_SRAM/PDPRAM/FIFO + IMFB\_DPRAM + IMFB\_CAM + IPLL\_D$$

### ICC\_DC

Use the appropriate value for 5000MC (1.8V power supply) or 5000MV/B (2.5V/3.3V power supply) from the data sheet.

### IMFB\_CPLD

$$= ((K0 * CPLD \text{ MFB inputs} + K1 * CPLD \text{ Logical Product Terms} + K2 * CPLD \text{ GRP from MFB} + K3 * CPLD \text{ GRP from IFB}) * AF + K4) * \text{FREQ} / 1000\mu\text{A/mA}$$

### IMFB\_CAM

$$= \text{CAM Memory MFBs} * ((\text{FREQ} * K8) + K9) \text{ (CAM operating in typical mode)}$$

### IMFB\_SRAM/PDPRAM/FIFO

$$= (\text{WR\_PERCENT} * (K1 + \text{WR\_PERCENT} * 8 * K0 + K10 + K11) + \text{RD\_PERCENT} * (K1 + 128 * \text{RD\_PERCENT} * K0 + 8 * \text{OSW\_PERCENT} * K2)) * \text{SRAM/PDPRAM/FIFO Memory MFBs} * \text{FREQ} / 1000\mu\text{A/mA}$$

### IMFB\_DPRAM

$$= (\text{WR\_PERCENT} * (2 * K1 + 2 * \text{WR\_PERCENT} * 8 * K0 + K10 + K11) + \text{RD\_PERCENT} * (2 * K1 + 2 * 128 * \text{RD\_PERCENT} * K0 + 8 * \text{OSW\_PERCENT} * K2)) * \text{DPRAM Memory MFBs} * \text{FREQ} / 1000\mu\text{A/mA}$$

### IPLL\_D

$$= K5 * \text{PLL\_FREQ} * \text{number of PLLs used. IPLL\_D is the PLL digital component of the VCC supply current.}$$

Analog portion of PLL supply current consumption, from PLL power pin:

$$IPLL\_A = (K6 * \text{PLL\_FREQ} + K7) * \text{number of PLLs used}$$

Notes:

- ICC = Current consumption of VCC power supply (mA)
- ICC-DC = ICC DC component – Current consumption at 0Mhz (mA)
- IMFB\_CPLD = CPLD (non-memory logic) current consumption (mA)
- IMFB\_SRAM/PDPRAM/FIFO = Current consumption for SRAM, PDPRAM, and FIFO (mA)
- IMFB\_DPRAM = Current consumption for DPRAM (mA)
- IMFB\_CAM = Current consumption for CAM (mA)
- IPLL\_D = PLL Current consumption of digital VCC power supply (mA)
- IPLL\_A = PLL analog power pin current consumption (VCCP pin)

ispXPLD 5256MX Logic Signal Connections

sysIO Bank	LVDS Pair	Primary Macrocell/ Function	Alternate Outputs		Alternate Input	256 fpBGA Ball Number
			Macrocell 1	Macrocell 2		
0	61N	H30	G17	H17	H31	B1
0	61P	H28	G16	H16	H29	C1
0	62N	H26	G15	H15	H27	D3
0	62P	H24	G14	H14	H25	C2
0	63N	H22	G13	H13	H23	E3
0	63P	H21	G12	H12	-	D2
-	-	VCC	-	-	-	VCC
0	64N	H20	G11	H11	-	E2
0	64P	H18/CLK_OUT0	G10	H10	H19	F2
0	65N	H16	G9	H9	H17	F1
0	65P	H14	G8	H8	H15	G1
-	-	GND	-	-	-	GND
0	66N	H12	G7	H7	H13	F3
-	-	VCCO0	-	-	-	VCCO0
0	66P	H10	G6	H6	H11	G5
-	-	GND (Bank 0)	-	-	-	GND (Bank 0)
0	67N	H8	G5	H5	H9	H5
0	67P	H6/PLL_RST0	G4	H4	H7	G4
0	68N	H5	-	-	-	G3
0	68P	H4/PLL_FBK0	-	-	-	H3
0	69N	H2	-	-	H3	G2
0	69P	H0	-	-	H1	H1
-	GCLK0P	GCLK0	-	-	-	H2
-	-	VCCJ	-	-	-	See Power Supply and NC Connections Table
-	GCLK0N	GCLK1	-	-	-	J2
-	-	GND	-	-	-	GND
-	-	TDI	-	-	-	H6
-	-	TMS	-	-	-	H4
-	-	TCK	-	-	-	J6
-	-	TDO	-	-	-	K2
1	0P	A0/DATA0	A0	B0	A1	K3
1	0N	A2/DATA1	A1	B1	A3	J3
1	1P	A4/DATA2	A2	B2	-	J5
1	1N	A5/DATA3	A3	B3	-	J4
1	2P	A6/DATA4	A4	B4	A7	L2
1	2N	A8/DATA5	A5	B5	A9	M1
-	-	GND (Bank 1)	-	-	-	GND (Bank 1)
1	3P	A10/DATA6	A6	B6	A11	K4
-	-	VCCO1	-	-	-	VCCO1
1	3N	A12/DATA7	A7	B7	A13	L3
-	-	GND	-	-	-	GND
1	4P	A14/INITB	A8	B8	A15	K5



ispXPLD 5512MX Logic Signal Connections

sysIO Bank	LVDS Pair	Primary Macrocell/ Function	Alternate Outputs		Alternate Input	208 PQFP Pin Number	256 fpBGA Ball Number	484 fpBGA Ball Number
			Macrocell 1	Macrocell 2				
0	109N	O30	O11	P18	O31	208	C4	B4
0	109P	O28	O10	P16	O29	1	E4	A4
0	110N	O26	M17	O17	O27	2	B1	B3
0	110P	O24	M16	O16	O25	3	C1	A3
0	111N	O22	M15	O15	O23	4	D3	F5
—	—	V <sub>CC00</sub>	—	—	—	5	V <sub>CC00</sub>	V <sub>CC00</sub>
0	111P	O20	M14	O14	O21	6	C2	G6
—	—	GND (Bank 0)	—	—	—	7	GND (Bank 0)	GND (Bank 0)
0	112N	O18	M13	O13	O19	8	E3	H6
0	112P	O16	M12	O12	O17	9	D2	G5
0	113N	O14	O9	P14	O15	—	—	D3
0	113P	O12	O8	P12	O13	—	—	D2
0	114N	O10	O7	P10	O11	—	—	E4
0	114P	O8	O6	P8	O9	—	—	E3
0	115N	O6	O5	P6	O7	—	—	F4
0	115P	O4	O4	P4	O5	—	—	G4
0	116N	O2	O3	P2	O3	—	—	C2
—	—	V <sub>CC00</sub>	—	—	—	—	V <sub>CC00</sub>	V <sub>CC00</sub>
0	116P	O0	O2	P0	O1	—	—	C1
—	—	GND (Bank 0)	—	—	—	—	GND (Bank 0)	GND (Bank 0)
0	117N	P30	O1	—	P31	—	D1	F3
0	117P	P28	O0	—	P29	—	E1	G3
0	118N	P26	O31	—	P27	—	F4	H4
—	—	V <sub>CC</sub>	—	—	—	10	V <sub>CC</sub>	V <sub>CC</sub>
0	118P	P24	O30	—	P25	—	F5	J4
0	119N	P22	M11	O11	P23	11	E2	H5
0	119P	P20/CLK_OUT0	M10	O10	P21	12	F2	J5
0	120N	P18	M9	O9	P19	13	F1	E2
0	120P	P16	M8	O8	P17	14	G1	F2
—	—	GND	—	—	—	15	GND	GND
0	121N	P14	M7	O7	P15	16	F3	D1
—	—	V <sub>CC00</sub>	—	—	—	17	V <sub>CC00</sub>	V <sub>CC00</sub>
0	121P	P12	M6	O6	P13	18	G5	E1
—	—	GND (Bank 0)	—	—	—	19	GND (Bank 0)	GND (Bank 0)
0	122N	P10	M5	O5	P11	20	H5	J3
0	122P	P8/PLL_RST0	M4	O4	P9	21	G4	H2
0	123N	P6	—	—	P7	22	G3	G2
0	123P	P4/PLL_FBK0	—	—	P5	23	H3	G1
0	124N	P2	—	—	P3	24	G2	H1
0	124P	P0	—	—	P1	25	H1	J1
—	GCLK0P	GCLK0	—	—	—	26	H2	N7
—	—	V <sub>CCJ</sub>	—	—	—	See Power Supply and NC Connections Table		

ispXPLD 5512MX Logic Signal Connections (Continued)

sysIO Bank	LVDS Pair	Primary Macrocell/ Function	Alternate Outputs		Alternate Input	208 PQFP Pin Number	256 fpBGA Ball Number	484 fpBGA Ball Number
			Macrocell 1	Macrocell 2				
—	—	V <sub>CCO2</sub>	—	—	—	85	V <sub>CCO2</sub>	V <sub>CCO2</sub>
2	29N	E10	F5	H5	E11	86	M10	U12
—	—	GND (Bank 2)	—	—	—	87	GND (Bank 2)	GND (Bank 2)
2	30P	E12	F6	H6	E13	88	M11	AB13
2	30N	E16	F7	H7	E17	89	T13	Y13
2	31P	E18	—	—	E19	90	P11	V13
2	31N	E20/V <sub>REF2</sub>	—	—	E21	91	T14	W13
2	32P	E22	F8	H8	E23	92	R12	V14
2	32N	E24	F9	H9	E25	93	R13	W14
2	33P	E26	F10	H10	E27	94	N11	Y14
2	33N	E28	F11	H11	E29	95	T15	AB14
2	34P	F0	F12	H12	F1	96	R14	AB15
2	34N	F2	F13	H13	F3	97	N12	AA15
2	35P	F4	F14	H14	F5	98	P12	U13
—	—	V <sub>CCO2</sub>	—	—	—	—	V <sub>CCO2</sub>	V <sub>CCO2</sub>
2	35N	F6	F15	H15	F7	99	R15	U14
—	—	GND (Bank 2)	—	—	—	—	GND (Bank 2)	GND (Bank 2)
2	36P	F8	E0	—	F9	—	—	W15
2	36N	F10	E2	—	F11	—	—	W16
2	37P	F12	E4	—	F13	—	—	Y16
2	37N	F16	E6	—	F17	—	—	AA16
2	38P	F18	E8	—	F19	—	—	AB16
2	38N	F20	E10	—	F21	—	—	AA17
2	39P	F22	E12	—	F23	—	—	Y17
2	39N	F24	E16	—	F25	—	—	AA18
2	40P	F26	E20	—	F27	—	—	W17
2	40N	F28	E22	—	F29	—	—	W18
2	41P	G0	—	—	G1	—	—	V15
—	—	V <sub>CCO2</sub>	—	—	—	100	V <sub>CCO2</sub>	V <sub>CCO2</sub>
2	41N	G2	—	—	G3	—	—	U15
—	—	GND (Bank 2)	—	—	—	101	GND (Bank 2)	GND (Bank 2)
2	42P	G4	—	—	G5	102	P13	Y18
2	42N	G6	—	—	G7	103	P15	V17
2	43P	G8	—	—	G9	—	M13	V16
2	43N	G10	—	—	G11	—	P14	U16
2	44P	G12	—	—	G13	—	—	AB18
2	44N	G14	—	—	G15	—	—	AB19
2	45P	G16	—	—	G17	—	—	U18
2	45N	G18	—	—	G19	—	—	T17
2	46P	G20	—	—	G21	104	R16	AB20
2	46N	G22	—	—	G23	105	P16	AA20
2	47P	G24	—	—	G25	106	N15	Y19
—	—	V <sub>CCO2</sub>	—	—	—	107	V <sub>CCO2</sub>	V <sub>CCO2</sub>

ispXPLD 5768MX Logic Signal Connections (Continued)

sysIO Bank	LVDS Pair	Primary Macrocell/ Function	Alternate Outputs		Alternate Inputs	256 fpBGA Ball Number	484 fpBGA Ball Number
			Macrocell 1	Macrocell 2			
3	93N	O0	P31	N31	O1	A13	E17
3	93P	O2	P30	N30	O3	B13	D17
-	-	GND (Bank 3)	-	-	-	GND (Bank 3)	GND (Bank 3)
3	94N	O4	N11	M21	O5	D11	B18
-	-	VCCO3	-	-	-	VCCO3	VCCO3
3	94P	O6	N10	M20	O7	B12	A18
-	-	GND	-	-	-	GND	GND
3	95N	O8	N9	M18	O9	C12	C17
-	-	VCC	-	-	-	VCC	VCC
3	95P	O10	N8	M16	O11	E11	B17
3	96N	O12	N7	M12	O13	-	C16
3	96P	O14	N6	M10	O15	-	B16
3	97N	O16	N5	M8	O17	-	F13
3	97P	O18	N4	M6	O19	-	F15
3	98N	O20	N3	M5	O21	-	D16
3	98P	O22	N2	M4	O23	E10	E16
3	99N	O24	N1	M2	O25	A12	A16
3	99P	O26	N0	M0	O27	A11	A15
-	-	GND (Bank 3)	-	-	-	GND (Bank 3)	GND (Bank 3)
3	100N	O28	P15	N15	O29	B11	B15
-	-	VCCO3	-	-	-	VCCO3	VCCO3
3	100P	O30	P14	N14	O31	C11	A14
3	101N	P0	P13	N13	P1	B10	D15
3	101P	P2	P12	N12	P3	A10	E15
3	102N	P4	P11	N11	P5	C10	D14
3	102P	P6	P10	N10	P7	D10	F14
3	103N	P8	P9	N9	P9	C9	A13
3	103P	P10	P8	N8	P11	E9	B13
3	104N	P12/VREF3	P29	N29	P13	D9	C14
3	104P	P14	P28	N28	P15	F9	E14
3	105N	P16	P7	N7	P17	A9	E13
3	105P	P18	P6	N6	P19	F8	F12
-	-	GND (Bank 3)	-	-	-	GND (Bank 3)	GND (Bank 3)
3	106N	P20	P5	N5	P21	E8	D13
-	-	VCCO3	-	-	-	VCCO3	VCCO3
3	106P	P22	P4	N4	P23	A8	C13
3	107N	P24	P3	N3	P25	B9	E12
-	-	GND	-	-	-	GND	GND
3	107P	P26	P2	N2	P27	D8	C12
-	-	VCC	-	-	-	VCC	VCC
3	108N	P28	P1	N1	P29	B8	B12
3	108P	P30	P0	N0	P31	C8	A12
0	109N	Q30	Q31	S31	Q31	B7	E11

ispXPLD 51024MX Logic Signal Connections (Continued)

sysIO Bank	LVDS Pair	Primary Macrocell/Function	Alternate Outputs		Alternate Input	484 fpBGA Ball Number	672 fpBGA Ball Number
			Macrocell 1	Macrocell 2			
0	175N	AC22	AC27	AE27	AC23	K6	J5
-	-	VCCO0	-	-	-	VCCO0	VCCO0
0	175P	AC20	AC26	AE26	AC21	K3	J4
-	-	GND (Bank 0)	-	-	-	GND (Bank 0)	GND (Bank 0)
0	176N	AC18	AC25	AE25	AC19	K5	K7
0	176P	AC16	AC24	AE24	AC17	K2	L7
0	177N	AC14	AC23	AE23	AC15	L5	J3
0	177P	AC12	AC22	AE22	AC13	K1	J2
0	178N	AC10	AC21	AE21	AC11	L6	K6
0	178P	AC8	AC20	AE20	AC9	L1	L6
0	179N	AC6	AC19	AE19	AC7	M5	K5
0	179P	AC4	AC18	AE18	AC5	L2	K4
0	180N	AC2	AC17	AE17	AC3	N5	K3
-	-	VCCO0	-	-	-	VCCO0	VCCO0
0	180P	AC0	AC16	AE16	AC1	L3	K2
-	-	GND (Bank 0)	-	-	-	GND (Bank 0)	GND (Bank 0)
0	181N	AE30	AC15	AE15	AE31	M6	K1
0	181P	AE28	AC14	AE14	AE29	M2	L2
0	182N	AE26	AC13	AE13	AE27	P5	L5
-	-	VCC	-	-	-	VCC	VCC
0	182P	AE24	AC12	AE12	AE25	P6	L4
0	183N	AE22	AC11	AE11	AE23	M3	L3
0	183P	AE20	AC10	AE10	AE21	N6	M3
0	184N	AE18	AC9	AE9	AE19	N2	M7
0	184P	AE16	AC8	AE8	AE17	P1	N7
-	-	GND	-	-	-	GND	GND
0	185N	AE14	AC7	AE7	AE15	N3	M5
-	-	VCCO0	-	-	-	VCCO0	VCCO0
0	185P	AE12	AC6	AE6	AE13	M8	M4
-	-	GND (Bank 0)	-	-	-	GND (Bank 0)	GND (Bank 0)
0	186N	AE10	AC5	AE5	AE11	N8	M6
0	186P	AE8	AC4	AE4	AE9	P2	N6
0	187N	AE6	AC3	AE3	AE7	P8	M2
0	187P	AE4	AC2	AE2	AE5	N4	M1
0	188N	AE2	AC1	AE1	AE3	H1	N1
0	188P	AE0	AC0	AE0	AE1	J1	N2
-	GCLK0P	GCLK0	-	-	-	N7	N5
-	-	VCCJ	-	-	-	See Power Supply and NC Connections Table	
-	GCLK0N	GCLK1	-	-	-	P7	N3
-	-	GND	-	-	-	GND	GND
-	-	TDI	-	-	-	R1	P4
-	-	TMS	-	-	-	R2	P5

ispXPLD 51024MX Logic Signal Connections (Continued)

sysIO Bank	LVDS Pair	Primary Macrocell/Function	Alternate Outputs		Alternate Input	484 fpBGA Ball Number	672 fpBGA Ball Number
			Macrocell 1	Macrocell 2			
-	-	GND (Bank 1)	-	-	-	GND (Bank 1)	GND (Bank 1)
1	31P	G26	H16	-	G27	V6	AB7
-	-	VCCO1	-	-	-	VCCO1	VCCO1
1	31N	G24	H18	-	G25	V7	AC7
-	-	GND	-	-	-	GND	GND
1	32P	G22	H20	-	G23	Y5	AB6
-	-	VCC	-	-	-	VCC	VCC
1	32N	G20	H22	-	G21	AA5	AC6
1	33P	G18	-	-	G19	Y6	AC8
1	33N	G16	-	-	G17	Y7	AC9
1	34P	G14	-	-	G15	AA6	AC5
1	34N	G12	-	-	G13	AA7	AD4
1	35P	G10	-	-	G11	W7	AD5
1	35N	G8	-	-	G9	V8	AD6
1	36P	G6	-	-	G7	W8	AD7
1	36N	G4	-	-	G5	U9	AD8
-	-	GND (Bank 1)	-	-	-	GND (Bank 1)	GND (Bank 1)
-	-	CFG0	-	-	-	U10	AE3
-	-	VCCO1	-	-	-	VCCO1	VCCO1
1	37P	G0	G16	E16	G1	AB7	AD9
1	37N	H30	G17	E17	H31	AA8	AD10
1	38P	H28	G18	E18	H29	AB8	AE4
1	38N	H26	G19	E19	H27	AB9	AE5
1	39P	H24	G20	E20	H25	W9	AE6
1	39N	H22	G21	E21	H23	Y9	AE7
1	40P	H20	G22	E22	H21	AB10	AE8
1	40N	H18	G23	E23	H19	AA10	AE9
1	-	H16/VREF1	-	-	H17	W10	AE10
1	41P	H14	G24	E24	H15	Y10	AF3
1	41N	H12	G25	E25	H13	Y11	AF4
-	-	GND (Bank 1)	-	-	-	GND (Bank 1)	GND (Bank 1)
1	42P	H10	G26	E26	H11	V9	AF5
-	-	VCCO1	-	-	-	VCCO1	VCCO1
1	42N	H8	G27	E27	H9	V10	AF6
1	43P	H6	G28	E28	H7	AA11	AF7
-	-	GND	-	-	-	GND	GND
1	43N	H4	G29	E29	H5	AB11	AF8
-	-	VCC	-	-	-	VCC	VCC
1	44P	H2	G30	E30	H3	U11	AF9
1	44N	H0	G31	E31	H1	V11	AF10
2	45P	I0	J0	L0	I1	AB12	AF17
-	-	VCC	-	-	-	VCC	VCC
2	45N	I2	J1	L1	I3	AA12	AF18

**ispXPLD 51024MX Logic Signal Connections (Continued)**

sysIO Bank	LVDS Pair	Primary Macrocell/Function	Alternate Outputs		Alternate Input	484 fpBGA Ball Number	672 fpBGA Ball Number
			Macrocell 1	Macrocell 2			
2	63P	K8	L20	-	K9	AA19	AA18
-	-	VCCO2	-	-	-	VCCO2	VCCO2
2	63N	K10	L21	-	K11	U17	Y18
-	-	GND (Bank 2)	-	-	-	GND (Bank 2)	GND (Bank 2)
2	64P	K12	L22	-	K13	V18	AD25
2	64N	K14	L23	-	K15	AB21	AD26
2	65P	K16	L24	-	K17	U18	AC23
2	65N	K18	L25	-	K19	T17	AC24
2	66P	K20	L26	-	K21	AB20	AC25
2	66N	K22	L27	-	K23	AA20	AC26
2	67P	K24	L28	-	K25	Y19	AB22
-	-	VCCO2	-	-	-	VCCO2	VCCO2
2	67N	K26	L29	-	K27	V19	AB23
-	-	GND (Bank 2)	-	-	-	GND (Bank 2)	GND (Bank 2)
2	68P	K28	J16	L16	K29	T18	AB24
2	68N	K30	J17	L17	K31	R17	AB25
2	69P	L0	J18	L18	L1	U19	AB26
2	69N	L2	J19	L19	L3	T19	AA26
2	70P	L4	L30	L24	L5	V20	AA22
-	-	VCC	-	-	-	VCC	VCC
2	70N	L6	L31	L26	L7	U20	Y21
2	71P	L8	J20	L20	L9	W20	AA23
2	71N	L10	J21	L21	L11	Y21	AA24
2	72P	L12	J22	L22	L13	R18	AA25
2	72N	L14	J23	L23	L15	R19	Y26
-	-	GND	-	-	-	GND	GND
2	73P	L16	J24	L24	L17	W21	Y22
-	-	VCCO2	-	-	-	VCCO2	VCCO2
2	73N	L18	J25	L25	L19	Y22	Y23
-	-	GND (Bank 2)	-	-	-	GND (Bank 2)	GND (Bank 2)
2	74P	L20	J26	L26	L21	R20	W20
2	74N	L22	J27	L27	L23	P20	V20
2	75P	L24	J28	L28	L25	T21	W21
2	75N	L26	J29	L29	L27	R21	V21
2	76P	L28	J30	L30	L29	U21	Y24
2	76N	L30	J31	L31	L31	V21	Y25
2	77P	N0	P0	N0	N1	—	W22
2	77N	N2	P1	N1	N3	—	W23
2	78P	N4	P2	N2	N5	—	W24
-	-	VCC	-	-	-	VCC	VCC
2	78N	N6	P3	N3	N7	—	W25
-	-	GND	-	-	-	GND	GND
2	79P	N8	P4	N4	N9	—	W26

ispXPLD 51024MX Logic Signal Connections (Continued)

sysIO Bank	LVDS Pair	Primary Macrocell/Function	Alternate Outputs		Alternate Input	484 fpBGA Ball Number	672 fpBGA Ball Number
			Macrocell 1	Macrocell 2			
-	-	VCCO2	-	-	-	VCCO2	VCCO2
2	79N	N10	P5	N5	N11	—	V26
-	-	GND (Bank 2)	-	-	-	GND (Bank 2)	GND (Bank 2)
2	80P	N12	P6	N6	N13	—	V22
2	80N	N14	P7	N7	N15	—	V23
2	81P	N16	P8	N8	N17	—	V24
2	81N	N18	P9	N9	N19	—	V25
2	82P	N20	P10	N10	N21	—	U20
2	82N	N22	P11	N11	N23	—	T20
2	83P	N24	P12	N12	N25	—	U26
2	83N	N26	P13	N13	N27	—	U25
2	84P	N28	P14	N14	N29	—	U21
-	-	VCCO2	-	-	-	VCCO2	VCCO2
2	84N	N30	P15	N15	N31	—	T21
-	-	GND (Bank 2)	-	-	-	GND (Bank 2)	GND (Bank 2)
2	85P	P0	P16	N16	P1	—	U22
2	85N	P2	P17	N17	P3	—	U23
2	86P	P4	P18	N18	P5	—	U24
2	86N	P6	P19	N19	P7	—	T24
2	87P	P8	P20	N20	P9	—	T23
2	87N	P10	P21	N21	P11	—	T22
2	88P	P12	P22	N22	P13	—	T25
-	-	VCC	-	-	-	VCC	VCC
2	88N	P14	P23	N23	P15	—	R26
-	-	GND	-	-	-	GND	GND
2	89P	P16	P24	N24	P17	—	R25
-	-	VCCO2	-	-	-	VCCO2	VCCO2
2	89N	P18	P25	N25	P19	—	R24
-	-	GND (Bank 2)	-	-	-	GND (Bank 2)	GND (Bank 2)
2	90P	P20	P26	N26	P21	—	R21
2	90N	P22	P27	N27	P23	—	P21
2	91P	P24	P28	N28	P25	—	R22
2	91N	P26	P29	N29	P27	—	R23
2	92P	P28	P30	N30	P29	—	R20
2	92N	P30	P31	N31	P31	—	P20
-	-	TOE	-	-	-	W22	P25
-	-	RESET	-	-	-	V22	P24
-	-	GOE0	-	-	-	T22	P23
-	-	GOE1	-	-	-	R22	P22
-	-	GNDP	-	-	-	See Power Supply and NC Connections Table	
-	GCLK3N	GCLK2	-	-	-	P16	N26
-	-	VCCP	-	-	-	See Power Supply and NC Connections Table	

## ispXPLD 51024MX Logic Signal Connections (Continued)

sysIO Bank	LVDS Pair	Primary Macrocell/Function	Alternate Outputs		Alternate Input	484 fpBGA Ball Number	672 fpBGA Ball Number
			Macrocell 1	Macrocell 2			
3	126N	W4	V11	U21	W5	B18	E19
-	-	VCCO3	-	-	-	VCCO3	VCCO3
3	126P	W6	V10	U20	W7	A18	E18
-	-	GND	-	-	-	GND	GND
3	127N	W8	V9	U18	W9	C17	C24
-	-	VCC	-	-	-	VCC	VCC
3	127P	W10	V8	U16	W11	B17	C23
3	128N	W12	V7	U12	W13	C16	D22
3	128P	W14	V6	U10	W15	B16	D21
3	129N	W16	V5	U8	W17	F13	E21
3	129P	W18	V4	U6	W19	F15	D20
3	130N	W20	V3	U5	W21	D16	D19
3	130P	W22	V2	U4	W23	E16	D18
3	131N	W24	V1	U2	W25	A16	C22
3	131P	W26	V0	U0	W27	A15	C21
-	-	GND (Bank 3)	-	-	-	GND (Bank 3)	GND (Bank 3)
3	132N	W28	X15	V15	W29	B15	C20
-	-	VCCO3	-	-	-	VCCO3	VCCO3
3	132P	W30	X14	V14	W31	A14	C19
3	133N	X0	X13	V13	X1	D15	C18
3	133P	X2	X12	V12	X3	E15	C17
3	134N	X4	X11	V11	X5	D14	B24
3	134P	X6	X10	V10	X7	F14	B23
3	135N	X8	X9	V9	X9	A13	B22
3	135P	X10	X8	V8	X11	B13	B21
3	136N	X12/VREF3	X29	V29	X13	C14	B20
3	136P	X14	X28	V28	X15	E14	B19
3	137N	X16	X7	V7	X17	E13	B18
3	137P	X18	X6	V6	X19	F12	B17
-	-	GND (Bank 3)	-	-	-	GND (Bank 3)	GND (Bank 3)
3	138N	X20	X5	V5	X21	D13	A24
-	-	VCCO3	-	-	-	VCCO3	VCCO3
3	138P	X22	X4	V4	X23	C13	A23
3	139N	X24	X3	V3	X25	E12	A22
-	-	GND	-	-	-	GND	GND
3	139P	X26	X2	V2	X27	C12	A21
-	-	VCC	-	-	-	VCC	VCC
3	140N	X28	X1	V1	X29	B12	A20
3	140P	X30	X0	V0	X31	A12	A19
0	141N	Y30	Y31	AA31	Y31	E11	A18
-	-	VCC	-	-	-	VCC	VCC
0	141P	Y28	Y30	AA30	Y29	C11	A17
-	-	GND	-	-	-	GND	GND



Global Clock LVDS pair options: GCLK0 and GCLK1, as well as GCLK2 and GCLK3, can be paired together to receive differential clocks; where GCLK0 and GCLK3 are the positive LVDS inputs.

**SELECT DEVICES  
DISCONTINUED**

### Part Number Description

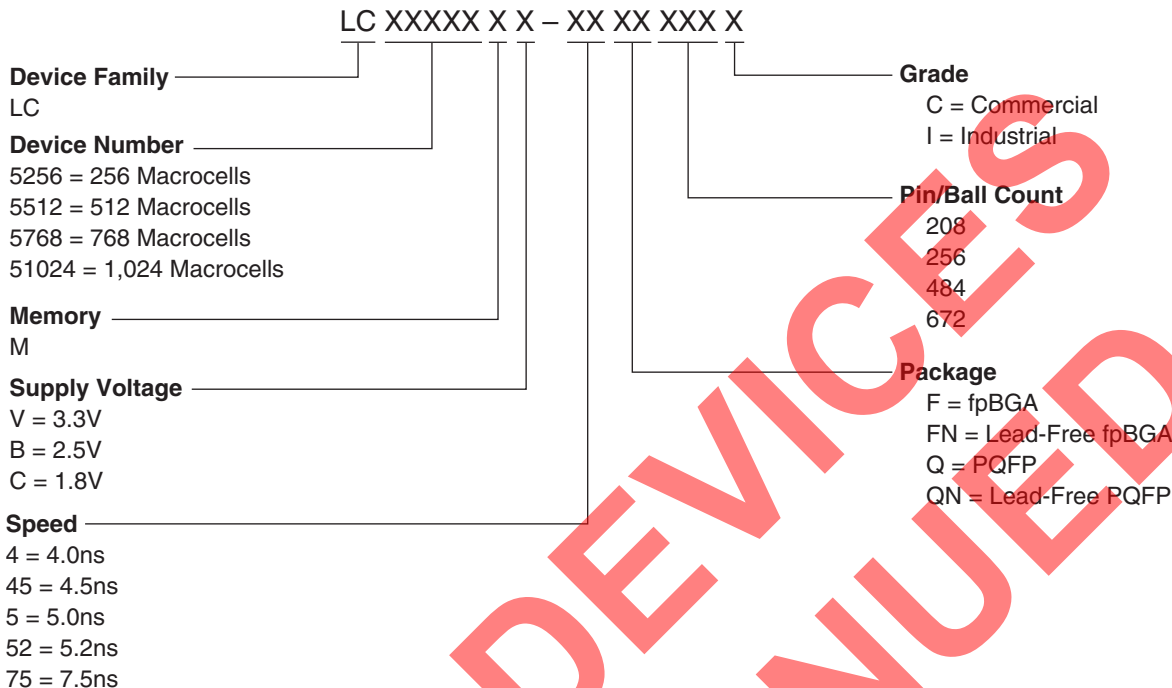

### Ordering Information

Note: For voltage families offered in industrial temperature grades and for all but the slowest commercial speed grade, the speed grades on these devices are dual marked. For example, the commercial speed grade -45XXXXC is also marked with the industrial grade -75I. The commercial grade is always one speed grade faster than the associated dual mark industrial grade. The slowest commercial speed grade is marked as commercial grade only. In addition, the fastest commercial speed grade (-5) for the LC5768MB/MV devices, at Lattice's discretion, will utilize either a commercial grade only single-mark or a dual-mark format in conjunction with the slower industrial speed grade (-75).

### Conventional Packaging

ispXPLD 5000MC (1.8V) Commercial Devices

Device	Part Number	Macrocells	Voltage (V)	t <sub>PD</sub> (ns)	Package	Pin/Ball Count	I/O	Grade
LC5256MC	LC5256MC-4F256C	256	1.8	4.0	fpBGA	256	141	C
	LC5256MC-5F256C	256	1.8	5.0	fpBGA	256	141	C
	LC5256MC-75F256C	256	1.8	7.5	fpBGA	256	141	C
LC5512MC	LC5512MC-45Q208C	512	1.8	4.5	PQFP	208	149	C
	LC5512MC-75Q208C	512	1.8	7.5	PQFP	208	149	C
	LC5512MC-45F256C	512	1.8	4.5	fpBGA	256	193	C
	LC5512MC-75F256C	512	1.8	7.5	fpBGA	256	193	C
	LC5512MC-45F484C	512	1.8	4.5	fpBGA	484	253	C
	LC5512MC-75F484C	512	1.8	7.5	fpBGA	484	253	C

**ispXPLD 5000MC (1.8V) Commercial Devices (Continued)**

Device	Part Number	Macrocells	Voltage (V)	t <sub>PD</sub> (ns)	Package	Pin/Ball Count	I/O	Grade
LC5768MC	LC5768MC-5F256C	768	1.8	5.0	fpBGA	256	193	C
	LC5768MC-75F256C	768	1.8	7.5	fpBGA	256	193	C
	LC5768MC-5F484C	768	1.8	5.0	fpBGA	484	317	C
	LC5768MC-75F484C	768	1.8	7.5	fpBGA	484	317	C
LC51024MC	LC51024MC-52F484C	1024	1.8	5.2	fpBGA	484	317	C
	LC51024MC-75F484C	1024	1.8	7.5	fpBGA	484	317	C
	LC51024MC-52F672C	1024	1.8	5.2	fpBGA	672	381	C
	LC51024MC-75F672C	1024	1.8	7.5	fpBGA	672	381	C

**ispXPLD 5000MC (1.8V) Industrial Devices**

Device	Part Number	Macrocells	Voltage (V)	t <sub>PD</sub> (ns)	Package	Pin/Ball Count	I/O	Grade
LC5256MC	LC5256MC-5F256I	256	1.8	5.0	fpBGA	256	141	I
	LC5256MC-75F256I	256	1.8	7.5	fpBGA	256	141	I
LC5512MC	LC5512MC-75Q208I	512	1.8	7.5	PQFP	208	149	I
	LC5512MC-75F256I	512	1.8	7.5	fpBGA	256	193	I
	LC5512MC-75F484I	512	1.8	7.5	fpBGA	484	253	I
LC5768MC	LC5768MC-75F256I	768	1.8	7.5	fpBGA	256	193	I
	LC5768MC-75F484I	768	1.8	7.5	fpBGA	484	317	I
LC51024MC	LC51024MC-75F484I	1024	1.8	7.5	fpBGA	484	317	I
	LC51024MC-75F672I	1024	1.8	7.5	fpBGA	672	381	I

**ispXPLD 5000MB (2.5V) Commercial Devices**

Device	Part Number	Macrocells	Voltage (V)	t <sub>PD</sub> (ns)	Package	Pin/Ball Count	I/O	Grade
LC5256MB	LC5256MB-4F256C	256	2.5	4.0	fpBGA	256	141	C
	LC5256MB-5F256C	256	2.5	5.0	fpBGA	256	141	C
	LC5256MB-75F256C	256	2.5	7.5	fpBGA	256	141	C
LC5512MB	LC5512MB-45Q208C	512	2.5	4.5	PQFP	208	149	C
	LC5512MB-75Q208C	512	2.5	7.5	PQFP	208	149	C
	LC5512MB-45F256C	512	2.5	4.5	fpBGA	256	193	C
	LC5512MB-75F256C	512	2.5	7.5	fpBGA	256	193	C
	LC5512MB-45F484C	512	2.5	4.5	fpBGA	484	253	C
	LC5512MB-75F484C	512	2.5	7.5	fpBGA	484	253	C
LC5768MB	LC5768MB-5F256C	768	2.5	5.0	fpBGA	256	193	C
	LC5768MB-75F256C	768	2.5	7.5	fpBGA	256	193	C
	LC5768MB-5F484C	768	2.5	5.0	fpBGA	484	317	C
	LC5768MB-75F484C	768	2.5	7.5	fpBGA	484	317	C
LC51024MB	LC51024MB-52F484C	1024	2.5	5.2	fpBGA	484	317	C
	LC51024MB-75F484C	1024	2.5	7.5	fpBGA	484	317	C
	LC51024MB-52F672C	1024	2.5	5.2	fpBGA	672	381	C
	LC51024MB-75F672C	1024	2.5	7.5	fpBGA	672	381	C

## ispXPLD 5000MB (2.5V) Industrial Devices

Device	Part Number	Macrocells	Voltage (V)	t <sub>PD</sub> (ns)	Package	Pin/Ball Count	I/O	Grade
LC5256MB	LC5256MB-5F256I	256	2.5	5.0	fpBGA	256	141	I
	LC5256MB-75F256I	256	2.5	7.5	fpBGA	256	141	I
LC5512MB	LC5512MB-75Q208I	512	2.5	7.5	PQFP	208	149	I
	LC5512MB-75F256I	512	2.5	7.5	fpBGA	256	193	I
	LC5512MB-75F484I	512	2.5	7.5	fpBGA	484	253	I
LC5768MB	LC5768MB-75F256I	768	2.5	7.5	fpBGA	256	193	I
	LC5768MB-75F484I	768	2.5	7.5	fpBGA	484	317	I
LC51024MB	LC51024MB-75F484I	1024	2.5	7.5	fpBGA	484	317	I
	LC51024MB-75F672I	1024	2.5	7.5	fpBGA	672	381	I

## ispXPLD 5000MV (3.3V) Commercial Devices

Device	Part Number	Macrocells	Voltage (V)	t <sub>PD</sub> (ns)	Package	Pin/Ball Count	I/O	Grade
LC5256MV	LC5256MV-4F256C	256	3.3	4.0	fpBGA	256	141	C
	LC5256MV-5F256C	256	3.3	5.0	fpBGA	256	141	C
	LC5256MV-75F256C	256	3.3	7.5	fpBGA	256	141	C
LC5512MV	LC5512MV-45Q208C	512	3.3	4.5	PQFP	208	149	C
	LC5512MV-75Q208C	512	3.3	7.5	PQFP	208	149	C
	LC5512MV-45F256C	512	3.3	4.5	fpBGA	256	193	C
	LC5512MV-75F256C	512	3.3	7.5	fpBGA	256	193	C
	LC5512MV-45F484C	512	3.3	4.5	fpBGA	484	253	C
	LC5512MV-75F484C	512	3.3	7.5	fpBGA	484	253	C
LC5768MV	LC5768MV-5F256C	768	3.3	5.0	fpBGA	256	193	C
	LC5768MV-75F256C	768	3.3	7.5	fpBGA	256	193	C
	LC5768MV-5F484C	768	3.3	5.0	fpBGA	484	317	C
	LC5768MV-75F484C	768	3.3	7.5	fpBGA	484	317	C
LC51024MV	LC51024MV-52F484C	1024	3.3	5.2	fpBGA	484	317	C
	LC51024MV-75F484C	1024	3.3	7.5	fpBGA	484	317	C
	LC51024MV-52F672C	1024	3.3	5.2	fpBGA	672	381	C
	LC51024MV-75F672C	1024	3.3	7.5	fpBGA	672	381	C

## ispXPLD 5000MV (3.3V) Industrial Devices

Device	Part Number	Macrocells	Voltage (V)	t <sub>PD</sub> (ns)	Package	Pin/Ball Count	I/O	Grade
LC5256MV	LC5256MV-5F256I	256	3.3	5.0	fpBGA	256	141	I
	LC5256MV-75F256I	256	3.3	7.5	fpBGA	256	141	I
LC5512MV	LC5512MV-75Q208I	512	3.3	7.5	PQFP	208	149	I
	LC5512MV-75F256I	512	3.3	7.5	fpBGA	256	193	I
	LC5512MV-75F484I	512	3.3	7.5	fpBGA	484	253	I
LC5768MV	LC5768MV-75F256I	768	3.3	7.5	fpBGA	256	193	I
	LC5768MV-75F484I	768	3.3	7.5	fpBGA	484	317	I
LC51024MV	LC51024MV-75F484I	1024	3.3	7.5	fpBGA	484	317	I
	LC51024MV-75F672I	1024	3.3	7.5	fpBGA	672	381	I

## Lead-Free Packaging

## ispXPLD 5000MC (1.8V) Lead-Free Commercial Devices

Device	Part Number	Macrocells	Voltage (V)	t <sub>PD</sub> (ns)	Package	Pin/Ball Count	I/O	Grade
LC5256MC	LC5256MC-4FN256C	256	1.8	4.0	Lead-free fpBGA	256	141	C
	LC5256MC-5FN256C	256	1.8	5.0	Lead-free fpBGA	256	141	C
	LC5256MC-75FN256C	256	1.8	7.5	Lead-free fpBGA	256	141	C
LC5512MC	LC5512MC-45QN208C	512	1.8	4.5	Lead-free PQFP	208	149	C
	LC5512MC-75QN208C	512	1.8	7.5	Lead-free PQFP	208	149	C
	LC5512MC-45FN256C	512	1.8	4.5	Lead-free fpBGA	256	193	C
	LC5512MC-75FN256C	512	1.8	7.5	Lead-free fpBGA	256	193	C
	LC5512MC-45FN484C	512	1.8	4.5	Lead-free fpBGA	484	253	C
	LC5512MC-75FN484C	512	1.8	7.5	Lead-free fpBGA	484	253	C
LC5768MC	LC5768MC-5FN256C	768	1.8	5.0	Lead-free fpBGA	256	193	C
	LC5768MC-75FN256C	768	1.8	7.5	Lead-free fpBGA	256	193	C
	LC5768MC-5FN484C	768	1.8	5.0	Lead-free fpBGA	484	317	C
	LC5768MC-75FN484C	768	1.8	7.5	Lead-free fpBGA	484	317	C
LC51024MC	LC51024MC-52FN484C	1024	1.8	5.2	Lead-free fpBGA	484	317	C
	LC51024MC-75FN484C	1024	1.8	7.5	Lead-free fpBGA	484	317	C
	LC51024MC-52FN672C	1024	1.8	5.2	Lead-free fpBGA	672	381	C
	LC51024MC-75FN672C	1024	1.8	7.5	Lead-free fpBGA	672	381	C

## ispXPLD 5000MC (1.8V) Lead-Free Industrial Devices

Device	Part Number	Macrocells	Voltage (V)	t <sub>PD</sub> (ns)	Package	Pin/Ball Count	I/O	Grade
LC5256MC	LC5256MC-5FN256I	256	1.8	5.0	Lead-free fpBGA	256	141	I
	LC5256MC-75FN256I	256	1.8	7.5	Lead-free fpBGA	256	141	I
LC5512MC	LC5512MC-75QN208I	512	1.8	7.5	Lead-free PQFP	208	149	I
	LC5512MC-75FN256I	512	1.8	7.5	Lead-free fpBGA	256	193	I
	LC5512MC-75FN484I	512	1.8	7.5	Lead-free fpBGA	484	253	I
LC5768MC	LC5768MC-75FN256I	768	1.8	7.5	Lead-free fpBGA	256	193	I
	LC5768MC-75FN484I	768	1.8	7.5	Lead-free fpBGA	484	317	I
LC51024MC	LC51024MC-75FN484I	1024	1.8	7.5	Lead-free fpBGA	484	317	I
	LC51024MC-75FN672I	1024	1.8	7.5	Lead-free fpBGA	672	381	I