

Welcome to [E-XFL.COM](https://www.e-xfl.com)

Embedded - System On Chip (SoC): The Heart of Modern Embedded Systems

Embedded - System On Chip (SoC) refers to an integrated circuit that consolidates all the essential components of a computer system into a single chip. This includes a microprocessor, memory, and other peripherals, all packed into one compact and efficient package. SoCs are designed to provide a complete computing solution, optimizing both space and power consumption, making them ideal for a wide range of embedded applications.

What are Embedded - System On Chip (SoC)?

System On Chip (SoC) integrates multiple functions of a computer or electronic system onto a single chip. Unlike traditional multi-chip solutions, SoCs combine a central

Details

Product Status	Active
Architecture	MCU, FPGA
Core Processor	Quad ARM® Cortex®-A53 MPCore™ with CoreSight™, Dual ARM®Cortex™-R5 with CoreSight™, ARM Mali™ -400 MP2
Flash Size	-
RAM Size	256KB
Peripherals	DMA, WDT
Connectivity	CANbus, EBI/EMI, Ethernet, I ² C, MMC/SD/SDIO, SPI, UART/USART, USB OTG
Speed	500MHz, 600MHz, 1.2GHz
Primary Attributes	Zynq@UltraScale+™ FPGA, 103K+ Logic Cells
Operating Temperature	-40°C ~ 100°C (Tj)
Package / Case	625-BFBGA, FCBGA
Supplier Device Package	625-FCBGA (21x21)
Purchase URL	https://www.e-xfl.com/product-detail/xilinx/xczu2eg-l1sfva625i

ARM Mali-400 Based GPU

- Supports OpenGL ES 1.1 and 2.0
- Supports OpenVG 1.1
- GPU frequency: Up to 667MHz
- Single Geometry Processor, Two Pixel Processors
- Pixel Fill Rate: 2 Mpixels/sec/MHz
- Triangle Rate: 0.11 Mtriangles/sec/MHz
- 64KB L2 Cache
- Power island gating

External Memory Interfaces

- Multi-protocol dynamic memory controller
- 32-bit or 64-bit interfaces to DDR4, DDR3, DDR3L, or LPDDR3 memories, and 32-bit interface to LPDDR4 memory
- ECC support in 64-bit and 32-bit modes
- Up to 32GB of address space using single or dual rank of 8-, 16-, or 32-bit-wide memories
- Static memory interfaces
 - eMMC4.51 Managed NAND flash support
 - ONFI3.1 NAND flash with 24-bit ECC
 - 1-bit SPI, 2-bit SPI, 4-bit SPI (Quad-SPI), or two Quad-SPI (8-bit) serial NOR flash

8-Channel DMA Controller

- Two DMA controllers of 8-channels each
- Memory-to-memory, memory-to-peripheral, peripheral-to-memory, and scatter-gather transaction support

Serial Transceivers

- Four dedicated PS-GTR receivers and transmitters supports up to 6.0Gb/s data rates
 - Supports SGMII tri-speed Ethernet, PCI Express® Gen2, Serial-ATA (SATA), USB3.0, and DisplayPort

Dedicated I/O Peripherals and Interfaces

- PCI Express — Compliant with PCIe® 2.1 base specification
 - Root complex and End Point configurations
 - x1, x2, and x4 at Gen1 or Gen2 rates
- SATA Host
 - 1.5, 3.0, and 6.0Gb/s data rates as defined by SATA Specification, revision 3.1
 - Supports up to two channels
- DisplayPort Controller
 - Up to 5.4Gb/s rate
 - Up to two TX lanes (no RX support)

- Four 10/100/1000 tri-speed Ethernet MAC peripherals with IEEE Std 802.3 and IEEE Std 1588 revision 2.0 support
 - Scatter-gather DMA capability
 - Recognition of IEEE Std 1588 rev.2 PTP frames
 - GMII, RGMII, and SGMII interfaces
 - Jumbo frames
- Two USB 3.0/2.0 Device, Host, or OTG peripherals, each supporting up to 12 endpoints
 - USB 3.0/2.0 compliant device IP core
 - Super-speed, high-speed, full-speed, and low-speed modes
 - Intel XHCI-compliant USB host
- Two full CAN 2.0B-compliant CAN bus interfaces
 - CAN 2.0-A and CAN 2.0-B and ISO 118981-1 standard compliant
- Two SD/SDIO 2.0/eMMC4.51 compliant controllers
- Two full-duplex SPI ports with three peripheral chip selects
- Two high-speed UARTs (up to 1Mb/s)
- Two master and slave I2C interfaces
- Up to 78 flexible multiplexed I/O (MIO) (up to three banks of 26 I/Os) for peripheral pin assignment
- Up to 96 EMIOs (up to three banks of 32 I/Os) connected to the PL

Interconnect

- High-bandwidth connectivity within PS and between PS and PL
- ARM AMBA® AXI4-based
- QoS support for latency and bandwidth control
- Cache Coherent Interconnect (CCI)

System Memory Management

- System Memory Management Unit (SMMU)
- Xilinx Memory Protection Unit (XMPU)

Platform Management Unit

- Power gates PS peripherals, power islands, and power domains
- Clock gates PS peripheral user firmware option

Configuration and Security Unit

- Boots PS and configures PL
- Supports secure and non-secure boot modes

System Monitor in PS

- On-chip voltage and temperature sensing

Programmable Logic (PL)

Configurable Logic Blocks (CLB)

- Look-up tables (LUT)
- Flip-flops
- Cascadable adders

36Kb Block RAM

- True dual-port
- Up to 72 bits wide
- Configurable as dual 18Kb

UltraRAM

- 288Kb dual-port
- 72 bits wide
- Error checking and correction

DSP Blocks

- 27 x 18 signed multiply
- 48-bit adder/accumulator
- 27-bit pre-adder

Programmable I/O Blocks

- Supports LVCMOS, LVDS, and SSTL
- 1.0V to 3.3V I/O
- Programmable I/O delay and SerDes

JTAG Boundary-Scan

- IEEE Std 1149.1 Compatible Test Interface

PCI Express

- Supports Root complex and End Point configurations
- Supports up to Gen4 speeds
- Up to five integrated blocks in select devices

100G Ethernet MAC/PCS

- IEEE Std 802.3 compliant
- CAUI-10 (10x 10.3125Gb/s) or CAUI-4 (4x 25.78125Gb/s)
- RSFEC (IEEE Std 802.3bj) in CAUI-4 configuration
- Up to four integrated blocks in select devices

Interlaken

- Interlaken spec 1.2 compliant
- 64/67 encoding
- 12 x 12.5Gb/s or 6 x 25Gb/s
- Up to four integrated blocks in select devices

Video Encoder/Decoder (VCU)

- Available in EV devices
- Accessible from either PS or PL
- Simultaneous encode and decode
- H.264 and H.265 support

System Monitor in PL

- On-chip voltage and temperature sensing
- 10-bit 200KSPS ADC with up to 17 external inputs

Table 2: Zynq UltraScale+ MPSoC: CG Device-Package Combinations and Maximum I/Os

Package (1)(2)(3)(4)(5)	Package Dimensions (mm)	ZU2CG	ZU3CG	ZU4CG	ZU5CG	ZU6CG	ZU7CG	ZU9CG
		HD, HP GTH, GTY	HD, HP GTH, GTY	HD, HP GTH, GTY	HD, HP GTH, GTY	HD, HP GTH, GTY	HD, HP GTH, GTY	HD, HP GTH, GTY
SBVA484 ⁽⁶⁾	19x19	24, 58 0, 0	24, 58 0, 0					
SFVA625	21x21	24, 156 0, 0	24, 156 0, 0					
SFVC784 ⁽⁷⁾	23x23	96, 156 0, 0	96, 156 0, 0	96, 156 4, 0	96, 156 4, 0			
FBVB900	31x31			48, 156 16, 0	48, 156 16, 0		48, 156 16, 0	
FFVC900	31x31					48, 156 16, 0		48, 156 16, 0
FFVB1156	35x35					120, 208 24, 0		120, 208 24, 0
FFVC1156	35x35						48, 312 20, 0	
FFVF1517	40x40						48, 416 24, 0	

Notes:

1. Go to [Ordering Information](#) for package designation details.
2. FB/FF packages have 1.0mm ball pitch. SB/SF packages have 0.8mm ball pitch.
3. All device package combinations bond out 4 PS-GTR transceivers.
4. All device package combinations bond out 214 PS I/O except ZU2CG and ZU3CG in the SBVA484 and SFVA625 packages, which bond out 170 PS I/Os.
5. Packages with the same last letter and number sequence, e.g., A484, are footprint compatible with all other UltraScale devices with the same sequence. The footprint compatible devices within this family are outlined.
6. All 58 HP I/O pins are powered by the same V_{CCO} supply.
7. GTH transceivers in the SFVC784 package support data rates up to 12.5Gb/s.

Table 4: Zynq UltraScale+ MPSoC: EG Device-Package Combinations and Maximum I/Os

Package (1)(2)(3)(4)(5)	Package Dimensions (mm)	ZU2EG	ZU3EG	ZU4EG	ZU5EG	ZU6EG	ZU7EG	ZU9EG	ZU11EG	ZU15EG	ZU17EG	ZU19EG
		HD, HP GTH, GTY	HD, HP GTH, GTY	HD, HP GTH, GTY	HD, HP GTH, GTY	HD, HP GTH, GTY	HD, HP GTH, GTY	HD, HP GTH, GTY	HD, HP GTH, GTY	HD, HP GTH, GTY	HD, HP GTH, GTY	HD, HP GTH, GTY
SBVA484(6)	19x19	24, 58 0, 0	24, 58 0, 0									
SFVA625	21x21	24, 156 0, 0	24, 156 0, 0									
SFVC784(7)	23x23	96, 156 0, 0	96, 156 0, 0	96, 156 4, 0	96, 156 4, 0							
FBVB900	31x31			48, 156 16, 0	48, 156 16, 0		48, 156 16, 0					
FFVC900	31x31					48, 156 16, 0		48, 156 16, 0		48, 156 16, 0		
FFVB1156	35x35					120, 208 24, 0		120, 208 24, 0		120, 208 24, 0		
FFVC1156	35x35						48, 312 20, 0		48, 312 20, 0			
FFVB1517	40x40								72, 416 16, 0		72, 572 16, 0	72, 572 16, 0
FFVF1517	40x40						48, 416 24, 0		48, 416 32, 0			
FFVC1760	42.5x42.5								96, 416 32, 16		96, 416 32, 16	96, 416 32, 16
FFVD1760	42.5x42.5										48, 260 44, 28	48, 260 44, 28
FFVE1924	45x45										96, 572 44, 0	96, 572 44, 0

Notes:

1. Go to [Ordering Information](#) for package designation details.(5)
2. FB/FF packages have 1.0mm ball pitch. SB/SF packages have 0.8mm ball pitch.
3. All device package combinations bond out 4 PS-GTR transceivers.
4. All device package combinations bond out 214 PS I/O except ZU2EG and ZU3EG in the SBVA484 and SFVA625 packages, which bond out 170 PS I/Os.
5. Packages with the same last letter and number sequence, e.g., A484, are footprint compatible with all other UltraScale devices with the same sequence. The footprint compatible devices within this family are outlined.
6. All 58 HP I/O pins are powered by the same V_{CC0} supply.
7. GTH transceivers in the SFVC784 package support data rates up to 12.5Gb/s.

Table 5: Zynq UltraScale+ MPSoC: EV Device Feature Summary

	ZU4EV	ZU5EV	ZU7EV
Application Processing Unit	Quad-core ARM Cortex-A53 MPCore with CoreSight; NEON & Single/Double Precision Floating Point; 32KB/32KB L1 Cache, 1MB L2 Cache		
Real-Time Processing Unit	Dual-core ARM Cortex-R5 with CoreSight; Single/Double Precision Floating Point; 32KB/32KB L1 Cache, and TCM		
Embedded and External Memory	256KB On-Chip Memory w/ECC; External DDR4; DDR3; DDR3L; LPDDR4; LPDDR3; External Quad-SPI; NAND; eMMC		
General Connectivity	214 PS I/O; UART; CAN; USB 2.0; I2C; SPI; 32b GPIO; Real Time Clock; WatchDog Timers; Triple Timer Counters		
High-Speed Connectivity	4 PS-GTR; PCIe Gen1/2; Serial ATA 3.1; DisplayPort 1.2a; USB 3.0; SGMII		
Graphic Processing Unit	ARM Mali™-400 MP2; 64KB L2 Cache		
Video Codec	1	1	1
System Logic Cells	192,150	256,200	504,000
CLB Flip-Flops	175,680	234,240	460,800
CLB LUTs	87,840	117,120	230,400
Distributed RAM (Mb)	2.6	3.5	6.2
Block RAM Blocks	128	144	312
Block RAM (Mb)	4.5	5.1	11.0
UltraRAM Blocks	48	64	96
UltraRAM (Mb)	14.0	18.0	27.0
DSP Slices	728	1,248	1,728
CMTs	4	4	8
Max. HP I/O ⁽¹⁾	156	156	416
Max. HD I/O ⁽²⁾	96	96	48
System Monitor	2	2	2
GTH Transceiver 16.3Gb/s ⁽³⁾	16	16	24
GTY Transceivers 32.75Gb/s	0	0	0
Transceiver Fractional PLLs	8	8	12
PCIe Gen3 x16 and Gen4 x8	2	2	2
150G Interlaken	0	0	0
100G Ethernet w/ RS-FEC	0	0	0

Notes:

1. HP = High-performance I/O with support for I/O voltage from 1.0V to 1.8V.
2. HD = High-density I/O with support for I/O voltage from 1.2V to 3.3V.
3. GTH transceivers in the SFVC784 package support data rates up to 12.5Gb/s. See [Table 6](#).

Table 6: Zynq UltraScale+ MPSoC: EV Device-Package Combinations and Maximum I/Os

Package (1)(2)(3)(4)	Package Dimensions (mm)	ZU4EV	ZU5EV	ZU7EV
		HD, HP GTH, GTY	HD, HP GTH, GTY	HD, HP GTH, GTY
SFVC784 ⁽⁵⁾	23x23	96, 156 4, 0	96, 156 4, 0	
FBVB900	31x31	48, 156 16, 0	48, 156 16, 0	48, 156 16, 0
FFVC1156	35x35			48, 312 20, 0
FFVF1517	40x40			48, 416 24, 0

Notes:

1. Go to [Ordering Information](#) for package designation details.
2. FB/FF packages have 1.0mm ball pitch. SF packages have 0.8mm ball pitch.
3. All device package combinations bond out 4 PS-GTR transceivers.
4. Packages with the same last letter and number sequence, e.g., C784, are footprint compatible with all other UltraScale devices with the same sequence. The footprint compatible devices within this family are outlined.
5. GTH transceivers in the SFVC784 package support data rates up to 12.5Gb/s.

- Audio support
 - A single stream carries up to 8 LPCM channels at 192kHz with 24-bit resolution
 - Supports compressed formats including DRA, Dolby MAT, and DTS HD
 - Multi-Stream Transport can extend the number of audio channels
 - Audio copy protection
 - 2-channel streaming or input from the PL
 - Multi-channel non-streaming audio from a memory audio frame buffer
- Includes a System Time Clock (STC) compliant with ISO/IEC 13818-1
- Boot-time display using minimum resources

Platform Management Unit (PMU)

- Performs system initialization during boot
- Acts as a delegate to the application and real-time processors during sleep state
- Initiates power-up and restart after the wake-up request
- Maintains the system power state at all time
- Manages the sequence of low-level events required for power-up, power-down, reset, clock gating, and power gating of islands and domains
- Provides error management (error handling and reporting)
- Provides safety check functions (e.g., memory scrubbing)

The PMU includes the following blocks:

- Platform management processor
- Fixed ROM for boot-up of the device
- 128KB RAM with ECC for optional user/firmware code
- Local and global registers to manage power-down, power-up, reset, clock gating, and power gating requests
- Interrupt controller with 16 interrupts from other modules and the inter-processor communication interface (IPI)
- GPI and GPO interfaces to and from PS I/O and PL
- JTAG interface for PMU debug
- Optional User-Defined Firmware

- Sleep Mode with automatic wake-up
- Snoop Mode
- 16-bit timestamping for receive messages
- Both internal generated reference clock and external reference clock input from MIO
- Guarantee clock sampling edge between 80 to 83% at 24MHz reference clock input
- Optional eFUSE disable per port

USB 2.0

- Two USB controllers (configurable as USB 2.0 or USB 3.0)
- Host, device and On-The-Go (OTG) modes
- High Speed, Full Speed, and Low Speed
- Up to 12 endpoints
- 8-bit ULPI External PHY Interface
- The USB host controller registers and data structures are compliant to Intel xHCI specifications.
- 64-bit AXI master port with built-in DMA
- Power management features: hibernation mode

Static Memory Interfaces

The static memory interfaces support external static memories.

- ONFI 3.1 NAND flash support with up to 24-bit ECC
- 1-bit SPI, 2-bit SPI, 4-bit SPI (Quad-SPI), or two Quad-SPI (8-bit) serial NOR flash
- 8-bit eMMC interface supporting managed NAND flash

NAND ONFI 3.1 Flash Controller

- ONFI 3.1 compliant
- Supports chip select reduction per ONFI 3.1 spec
- SLC NAND for boot/configuration and data storage
- ECC options based on SLC NAND
 - 1, 4, or 8 bits per 512+spare bytes
 - 24 bits per 1024+spare bytes
- Maximum throughput as follows
 - Asynchronous mode (SDR) 24.3MB/s
 - Synchronous mode (NV-DDR) 112MB/s (for 100MHz flash clock)
- 8-bit SDR NAND interface

Table 8: MIO Peripheral Interface Mapping

Peripheral Interface	MIO	EMIO
Quad-SPI NAND	Yes	No
USB2.0: 0,1	Yes: External PHY	No
SDIO 0,1	Yes	Yes
SPI: 0,1 I2C: 0,1 CAN: 0,1 GPIO	Yes CAN: External PHY GPIO: Up to 78 bits	Yes CAN: External PHY GPIO: Up to 96 bits
GigE: 0,1,2,3	RGMII v2.0: External PHY	Supports GMII, RGMII v2.0 (HSTL), RGMII v1.3, MII, SGMII, and 1000BASE-X in Programmable Logic
UART: 0,1	Simple UART: Only two pins (TX and RX)	Full UART (TX, RX, DTR, DCD, DSR, RI, RTS, and CTS) requires either: <ul style="list-style-type: none"> • Two Processing System (PS) pins (RX and TX) through MIO and six additional Programmable Logic (PL) pins, <i>or</i> • Eight Programmable Logic (PL) pins
Debug Trace Ports	Yes: Up to 16 trace bits	Yes: Up to 32 trace bits
Processor JTAG	Yes	Yes

Transceiver (PS-GTR)

The four PS-GTR transceivers, which reside in the full power domain (FPD), support data rates of up to 6.0Gb/s. All the protocols cannot be pinned out at the same time. At any given time, four differential pairs can be pinned out using the transceivers. This is user programmable via the high-speed I/O multiplexer (HS-MIO).

- A Quad transceiver PS-GTR (TX/RX pair) able to support following standards simultaneously
 - x1, x2, or x4 lane of PCIe at Gen1 (2.5Gb/s) or Gen2 (5.0Gb/s) rates
 - 1 or 2 lanes of DisplayPort (TX only) at 1.62Gb/s, 2.7Gb/s, or 5.4Gb/s
 - 1 or 2 SATA channels at 1.5Gb/s, 3.0Gb/s, or 6.0Gb/s
 - 1 or 2 USB3.0 channels at 5.0Gb/s
 - 1-4 Ethernet SGMII channels at 1.25Gb/s
- Provides flexible host-programmable multiplexing function for connecting the transceiver resources to the PS masters (DisplayPort, PCIe, Serial-ATA, USB3.0, and GigE).

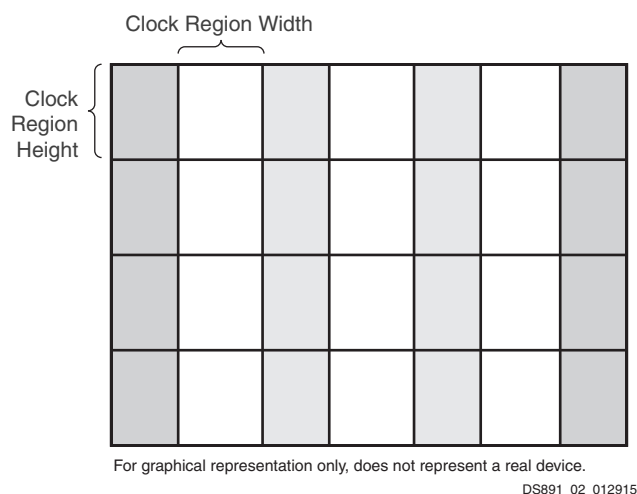

Figure 2: Column-Based Device Divided into Clock Regions

Input/Output

All Zynq UltraScale+ MPSoCs have I/O pins for communicating to external components. In addition, in the MPSoC's PS, there are another 78 I/Os that the I/O peripherals use to communicate to external components, referred to as multiplexed I/O (MIO). If more than 78 pins are required by the I/O peripherals, the I/O pins in the PL can be used to extend the MPSoC interfacing capability, referred to as extended MIO (EMIO).

The number of I/O pins in the PL of Zynq UltraScale+ MPSoCs varies depending on device and package. Each I/O is configurable and can comply with a large number of I/O standards. The I/Os are classed as high-performance (HP), or high-density (HD). The HP I/Os are optimized for highest performance operation, from 1.0V to 1.8V. The HD I/Os are reduced-feature I/Os organized in banks of 24, providing voltage support from 1.2V to 3.3V.

All I/O pins are organized in banks, with 52 HP pins per bank or 24 HD pins per bank. Each bank has one common V_{CC0} output buffer power supply, which also powers certain input buffers. Some single-ended input buffers require an internally generated or an externally applied reference voltage (V_{REF}). V_{REF} pins can be driven directly from the PCB or internally generated using the internal V_{REF} generator circuitry present in each bank.

I/O Electrical Characteristics

Single-ended outputs use a conventional CMOS push/pull output structure driving High towards V_{CC0} or Low towards ground, and can be put into a high-Z state. The system designer can specify the slew rate and the output strength. The input is always active but is usually ignored while the output is active. Each pin can optionally have a weak pull-up or a weak pull-down resistor.

Most signal pin pairs can be configured as differential input pairs or output pairs. Differential input pin pairs can optionally be terminated with a 100 Ω internal resistor. All UltraScale architecture-based devices support differential standards beyond LVDS, including RSDS, BLVDS, differential SSTL, and differential HSTL. Each of the I/Os supports memory I/O standards, such as single-ended and differential HSTL as well as single-ended and differential SSTL. The Zynq UltraScale+ family includes support for MIPI with a dedicated D-PHY in the I/O bank.

3-State Digitally Controlled Impedance and Low Power I/O Features

The 3-state Digitally Controlled Impedance (T_DCI) can control the output drive impedance (series termination) or can provide parallel termination of an input signal to V_{CCO} or split (Thevenin) termination to $V_{CCO}/2$. This allows users to eliminate off-chip termination for signals using T_DCI. In addition to board space savings, the termination automatically turns off when in output mode or when 3-stated, saving considerable power compared to off-chip termination. The I/Os also have low power modes for IBUF and IDELAY to provide further power savings, especially when used to implement memory interfaces.

I/O Logic

Input and Output Delay

All inputs and outputs can be configured as either combinatorial or registered. Double data rate (DDR) is supported by all inputs and outputs. Any input or output can be individually delayed by up to 1,250ps of delay with a resolution of 5–15ps. Such delays are implemented as IDELAY and ODELAY. The number of delay steps can be set by configuration and can also be incremented or decremented while in use. The IDELAY and ODELAY can be cascaded together to double the amount of delay in a single direction.

ISERDES and OSERDES

Many applications combine high-speed, bit-serial I/O with slower parallel operation inside the device. This requires a serializer and deserializer (SerDes) inside the I/O logic. Each I/O pin possesses an IOSERDES (ISERDES and OSERDES) capable of performing serial-to-parallel or parallel-to-serial conversions with programmable widths of 2, 4, or 8 bits. These I/O logic features enable high-performance interfaces, such as Gigabit Ethernet/1000BaseX/SGMII, to be moved from the transceivers to the SelectIO interface.

High-Speed Serial Transceivers

Ultra-fast serial data transmission between devices on the same PCB, over backplanes, and across even longer distances is becoming increasingly important for scaling to 100 Gb/s and 400 Gb/s line cards. Specialized dedicated on-chip circuitry and differential I/O capable of coping with the signal integrity issues are required at these high data rates.

Three types of transceivers are used in Zynq UltraScale+ MPSoCs: GTH, GTY, and PS-GTR. All transceivers are arranged in groups of four, known as a transceiver Quad. Each serial transceiver is a combined transmitter and receiver. [Table 10](#) compares the available transceivers.

Table 10: Transceiver Information

	Zynq UltraScale+ MPSoCs		
Type	PS-GTR	GTH	GTY
Qty	4	0–44	0–28
Max. Data Rate	6.0Gb/s	16.3Gb/s	32.75Gb/s
Min. Data Rate	1.25Gb/s	0.5Gb/s	0.5Gb/s
Applications	<ul style="list-style-type: none"> • PCIe Gen2 • USB • Ethernet 	<ul style="list-style-type: none"> • Backplane • PCIe Gen4 • HMC 	<ul style="list-style-type: none"> • 100G+ Optics • Chip-to-Chip • 25G+ Backplane • HMC

The following information in this section pertains to the GTH and GTY only.

The serial transmitter and receiver are independent circuits that use an advanced phase-locked loop (PLL) architecture to multiply the reference frequency input by certain programmable numbers between 4 and 25 to become the bit-serial data clock. Each transceiver has a large number of user-definable features and parameters. All of these can be defined during device configuration, and many can also be modified during operation.

Transmitter

The transmitter is fundamentally a parallel-to-serial converter with a conversion ratio of 16, 20, 32, 40, 64, or 80 for the GTH and 16, 20, 32, 40, 64, 80, 128, or 160 for the GTY. This allows the designer to trade off datapath width against timing margin in high-performance designs. These transmitter outputs drive the PC board with a single-channel differential output signal. TXOUTCLK is the appropriately divided serial data clock and can be used directly to register the parallel data coming from the internal logic. The incoming parallel data is fed through an optional FIFO and has additional hardware support for the 8B/10B, 64B/66B, or 64B/67B encoding schemes to provide a sufficient number of transitions. The bit-serial output signal drives two package pins with differential signals. This output signal pair has programmable signal swing as well as programmable pre- and post-emphasis to compensate for PC board losses and other interconnect characteristics. For shorter channels, the swing can be reduced to reduce power consumption.

Receiver

The receiver is fundamentally a serial-to-parallel converter, changing the incoming bit-serial differential signal into a parallel stream of words, each 16, 20, 32, 40, 64, or 80 bits in the GTH or 16, 20, 32, 40, 64, 80, 128, or 160 for the GTY. This allows the designer to trade off internal datapath width against logic timing margin. The receiver takes the incoming differential data stream, feeds it through programmable DC automatic gain control, linear and decision feedback equalizers (to compensate for PC board, cable, optical and other interconnect characteristics), and uses the reference clock input to initiate clock recognition. There is no need for a separate clock line. The data pattern uses non-return-to-zero (NRZ) encoding and optionally ensures sufficient data transitions by using the selected encoding scheme. Parallel data is then transferred into the device logic using the RXUSRCLK clock. For short channels, the transceivers offer a special low-power mode (LPM) to reduce power consumption by approximately 30%. The receiver DC automatic gain control and linear and decision feedback equalizers can optionally “auto-adapt” to automatically learn and compensate for different interconnect characteristics. This enables even more margin for tough 10G+ and 25G+ backplanes.

Out-of-Band Signaling

The transceivers provide out-of-band (OOB) signaling, often used to send low-speed signals from the transmitter to the receiver while high-speed serial data transmission is not active. This is typically done when the link is in a powered-down state or has not yet been initialized. This benefits PCIe and SATA/SAS and QPI applications.

Integrated Interface Blocks for PCI Express Designs

The MPSoC PL includes integrated blocks for PCIe technology that can be configured as an Endpoint or Root Port, compliant to the PCI Express Base Specification Revision 3.1 for Gen3 and lower data rates and compatible with the PCI Express Base Specification Revision 4.0 (rev 0.5) for Gen4 data rates. The Root Port can be used to build the basis for a compatible Root Complex, to allow custom chip-to-chip communication via the PCI Express protocol, and to attach ASSP Endpoint devices, such as Ethernet Controllers or Fibre Channel HBAs, to the MPSoC.

This block is highly configurable to system design requirements and can operate 1, 2, 4, 8, or 16 lanes at up to 2.5Gb/s, 5.0Gb/s, 8.0Gb/s, or 16Gb/s data rates. For high-performance applications, advanced buffering techniques of the block offer a flexible maximum payload size of up to 1,024 bytes. The integrated block interfaces to the integrated high-speed transceivers for serial connectivity and to block RAMs for data buffering. Combined, these elements implement the Physical Layer, Data Link Layer, and Transaction Layer of the PCI Express protocol.

Xilinx provides a light-weight, configurable, easy-to-use LogiCORE™ IP wrapper that ties the various building blocks (the integrated block for PCIe, the transceivers, block RAM, and clocking resources) into an Endpoint or Root Port solution. The system designer has control over many configurable parameters: link width and speed, maximum payload size, MPSoC logic interface speeds, reference clock frequency, and base address register decoding and filtering.

Integrated Block for Interlaken

Some UltraScale architecture-based devices include integrated blocks for Interlaken. Interlaken is a scalable chip-to-chip interconnect protocol designed to enable transmission speeds from 10Gb/s to 150Gb/s. The Interlaken integrated block in the UltraScale architecture is compliant to revision 1.2 of the Interlaken specification with data striping and de-striping across 1 to 12 lanes. Permitted configurations are: 1 to 12 lanes at up to 12.5Gb/s and 1 to 6 lanes at up to 25.78125Gb/s, enabling flexible support for up to 150Gb/s per integrated block. With multiple Interlaken blocks, certain UltraScale architecture-based devices enable easy, reliable Interlaken switches and bridges.

PLL

With fewer features than the MMCM, the two PLLs in a clock management tile are primarily present to provide the necessary clocks to the dedicated memory interface circuitry. The circuit at the center of the PLLs is similar to the MMCM, with PFD feeding a VCO and programmable M, D, and O counters. There are two divided outputs to the device fabric per PLL as well as one clock plus one enable signal to the memory interface circuitry.

Zynq UltraScale+ MPSoCs are equipped with five additional PLLs in the PS for independently configuring the four primary clock domains with the PS: the APU, the RPU, the DDR controller, and the I/O peripherals.

Clock Distribution

Clocks are distributed throughout Zynq UltraScale+ MPSoCs via buffers that drive a number of vertical and horizontal tracks. There are 24 horizontal clock routes per clock region and 24 vertical clock routes per clock region with 24 additional vertical clock routes adjacent to the MMCM and PLL. Within a clock region, clock signals are routed to the device logic (CLBs, etc.) via 16 gateable leaf clocks.

Several types of clock buffers are available. The BUFGCE and BUFCE_LEAF buffers provide clock gating at the global and leaf levels, respectively. BUFGCTRL provides glitchless clock muxing and gating capability. BUFGCE_DIV has clock gating capability and can divide a clock by 1 to 8. BUFG_GT performs clock division from 1 to 8 for the transceiver clocks. In MPSoCs, clocks can be transferred from the PS to the PL using dedicated buffers.

Memory Interfaces

Memory interface data rates continue to increase, driving the need for dedicated circuitry that enables high performance, reliable interfacing to current and next-generation memory technologies. Every Zynq UltraScale+ MPSoC includes dedicated physical interfaces (PHY) blocks located between the CMT and I/O columns that support implementation of high-performance PHY blocks to external memories such as DDR4, DDR3, QDRII+, and RLDRAM3. The PHY blocks in each I/O bank generate the address/control and data bus signaling protocols as well as the precision clock/data alignment required to reliably communicate with a variety of high-performance memory standards. Multiple I/O banks can be used to create wider memory interfaces.

As well as external parallel memory interfaces, Zynq UltraScale+ MPSoC can communicate to external serial memories, such as Hybrid Memory Cube (HMC), via the high-speed serial transceivers. All transceivers in the UltraScale architecture support the HMC protocol, up to 15Gb/s line rates. UltraScale architecture-based devices support the highest bandwidth HMC configuration of 64 lanes with a single device.

Programmable Data Width

Each port can be configured as $32K \times 1$; $16K \times 2$; $8K \times 4$; $4K \times 9$ (or 8); $2K \times 18$ (or 16); $1K \times 36$ (or 32); or 512×72 (or 64). Whether configured as block RAM or FIFO, the two ports can have different aspect ratios without any constraints. Each block RAM can be divided into two completely independent 18Kb block RAMs that can each be configured to any aspect ratio from $16K \times 1$ to 512×36 . Everything described previously for the full 36Kb block RAM also applies to each of the smaller 18Kb block RAMs. Only in simple dual-port (SDP) mode can data widths of greater than 18 bits (18Kb RAM) or 36 bits (36Kb RAM) be accessed. In this mode, one port is dedicated to read operation, the other to write operation. In SDP mode, one side (read or write) can be variable, while the other is fixed to 32/36 or 64/72. Both sides of the dual-port 36Kb RAM can be of variable width.

Error Detection and Correction

Each 64-bit-wide block RAM can generate, store, and utilize eight additional Hamming code bits and perform single-bit error correction and double-bit error detection (ECC) during the read process. The ECC logic can also be used when writing to or reading from external 64- to 72-bit-wide memories.

FIFO Controller

Each block RAM can be configured as a 36Kb FIFO or an 18Kb FIFO. The built-in FIFO controller for single-clock (synchronous) or dual-clock (asynchronous or multirate) operation increments the internal addresses and provides four handshaking flags: full, empty, programmable full, and programmable empty. The programmable flags allow the user to specify the FIFO counter values that make these flags go active. The FIFO width and depth are programmable with support for different read port and write port widths on a single FIFO. A dedicated cascade path allows for easy creation of deeper FIFOs.

UltraRAM

UltraRAM is a high-density, dual-port, synchronous memory block used in some UltraScale+ families. Both of the ports share the same clock and can address all of the $4K \times 72$ bits. Each port can independently read from or write to the memory array. UltraRAM supports two types of write enable schemes. The first mode is consistent with the block RAM byte write enable mode. The second mode allows gating the data and parity byte writes separately. Multiple UltraRAM blocks can be cascaded together to create larger memory arrays. UltraRAM blocks can be connected together to create larger memory arrays. Dedicated routing in the UltraRAM column enables the entire column height to be connected together. This makes UltraRAM an ideal solution for replacing external memories such as SRAM. Cascadable anywhere from 288Kb to 36Mb, UltraRAM provides the flexibility to fulfill many different memory requirements.

Error Detection and Correction

Each 64-bit-wide UltraRAM can generate, store and utilize eight additional Hamming code bits and perform single-bit error correction and double-bit error detection (ECC) during the read process.

Digital Signal Processing

DSP applications use many binary multipliers and accumulators, best implemented in dedicated DSP slices. All UltraScale architecture-based devices have many dedicated, low-power DSP slices, combining high speed with small size while retaining system design flexibility.

Each DSP slice fundamentally consists of a dedicated 27×18 bit twos complement multiplier and a 48-bit accumulator. The multiplier can be dynamically bypassed, and two 48-bit inputs can feed a single-instruction-multiple-data (SIMD) arithmetic unit (dual 24-bit add/subtract/accumulate or quad 12-bit add/subtract/accumulate), or a logic unit that can generate any one of ten different logic functions of the two operands.

The DSP includes an additional pre-adder, typically used in symmetrical filters. This pre-adder improves performance in densely packed designs and reduces the DSP slice count by up to 50%. The 96-bit-wide XOR function, programmable to 12, 24, 48, or 96-bit widths, enables performance improvements when implementing forward error correction and cyclic redundancy checking algorithms.

The DSP also includes a 48-bit-wide pattern detector that can be used for convergent or symmetric rounding. The pattern detector is also capable of implementing 96-bit-wide logic functions when used in conjunction with the logic unit.

The DSP slice provides extensive pipelining and extension capabilities that enhance the speed and efficiency of many applications beyond digital signal processing, such as wide dynamic bus shifters, memory address generators, wide bus multiplexers, and memory-mapped I/O register files. The accumulator can also be used as a synchronous up/down counter.

System Monitor

The System Monitor blocks in the UltraScale architecture are used to enhance the overall safety, security, and reliability of the system by monitoring the physical environment via on-chip power supply and temperature sensors.

All UltraScale architecture-based devices contain at least one System Monitor. The System Monitor in UltraScale+ devices is similar to the Kintex UltraScale and Virtex UltraScale devices but with the addition of a PMBus interface.

Zynq UltraScale+ MPSoCs contain one System Monitor in the PL and an additional block in the PS. The System Monitor in the PL has the same features as the block in UltraScale+ FPGAs. See [Table 11](#).

Table 11: Key System Monitor Features

	Zynq UltraScale+ MPSoC PL	Zynq UltraScale+ MPSoC PS
ADC	10-bit 200kSPS	10-bit 1MSPS
Interfaces	JTAG, I2C, DRP, PMBus	APB

In FPGAs and the MPSoC PL, sensor outputs and up to 17 user-allocated external analog inputs are digitized using a 10-bit 200 kilo-sample-per-second (kSPS) ADC, and the measurements are stored in registers that can be accessed via internal FPGA (DRP), JTAG, PMBus, or I2C interfaces. The I2C interface and PMBus allow the on-chip monitoring to be easily accessed by the System Manager/Host before and after device configuration.

The System Monitor in the MPSoC PS uses a 10-bit, 1 mega-sample-per-second (MSPS) ADC to digitize the sensor inputs. The measurements are stored in registers and are accessed via the Advanced Peripheral Bus (APB) interface by the processors and the PMU in the PS.

Packaging

The UltraScale architecture-based devices are available in a variety of organic flip-chip and lidless flip-chip packages supporting different quantities of I/Os and transceivers. Maximum supported performance can depend on the style of package and its material. Always refer to the specific device data sheet for performance specifications by package type.

In flip-chip packages, the silicon device is attached to the package substrate using a high-performance flip-chip process. Decoupling capacitors are mounted on the package substrate to optimize signal integrity under simultaneous switching of outputs (SSO) conditions.

System-Level Features

Several functions span both the PS and PL and include:

- Reset Management
- Clock Management
- Power Domains
- PS Boot and Device Configuration
- Hardware and Software Debug Support

Reset Management

The reset management function provides the ability to reset the entire device or individual units within it. The PS supports these reset functions and signals:

- External and internal power-on reset signal
- Warm reset
- Watchdog timer reset
- User resets to PL
- Software, watchdog timer, or JTAG provided resets
- Security violation reset (locked down reset)

Clock Management

The PS in Zynq UltraScale+ MPSoCs is equipped with five phase-locked loops (PLLs), providing flexibility in configuring the clock domains within the PS. There are four primary clock domains of interest within the PS. These include the APU, the RPU, the DDR controller, and the I/O peripherals (IOP). The frequencies of all of these domains can be configured independently under software control.

Power Domains

The Zynq UltraScale+ MPSoC contains four separate power domains. When they are connected to separate power supplies, they can be completely powered down independently of each other without consuming any dynamic or static power. The processing system includes:

- Full Power Domain (FPD)
- Low Power Domain (LPD)
- Battery Powered Domain (BPD)

In addition to these three Processing System power domains, the PL can also be completely powered down if connected to separate power supplies.

The Full Power Domain (FPD) consists of the following major blocks:

- Application Processing Unit (APU)
- DMA (FP-DMA)
- Graphics Processing Unit (GPU)
- Dynamic Memory Controller (DDRC)
- High-Speed I/O Peripherals

The Low Power Domain (LPD) consists of the following major blocks:

- Real-Time Processing Unit (RPU)
- DMA (LP-DMA)
- Platform Management Unit (PMU)
- Configuration Security Unit (CSU)
- Low-Speed I/O Peripherals
- Static Memory Interfaces

The Battery Power Domain (BPD) is the lowest power domain of the Zynq UltraScale+ MPSoC processing system. In this mode, all the PS is powered off except the Real-Time Clock (RTC) and battery-backed RAM (BBRAM).

Power Examples

Power for the Zynq UltraScale+ MPSoCs varies depending on the utilization of the PL resources, and the frequency of the PS and PL. To estimate power, use the Xilinx Power Estimator (XPE) at:

http://www.xilinx.com/products/design_tools/logic_design/xpe.htm

Ordering Information

Table 12 shows the speed and temperature grades available in the different device families.

Table 12: Speed Grade and Temperature Grade

Device Family	Devices	Speed Grade and Temperature Grade				
		Commercial (C)	Extended (E)		Industrial (I)	
		0°C to +85°C	0°C to +100°C	0°C to +110°C	-40°C to +100°C	
Zynq UltraScale+	CG Devices		-2E (0.85V)		-2I (0.85V)	
				-2LE ⁽¹⁾⁽²⁾ (0.85V or 0.72V)		
			-1E (0.85V)		-1I (0.85V)	
					-1LI ⁽²⁾ (0.85V or 0.72V)	
	ZU2EG ZU3EG		-2E (0.85V)		-2I (0.85V)	
				-2LE ⁽¹⁾⁽²⁾ (0.85V or 0.72V)		
			-1E (0.85V)		-1I (0.85V)	
					-1LI ⁽²⁾ (0.85V or 0.72V)	
	ZU4EG ZU5EG ZU6EG ZU7EG ZU9EG ZU11EG ZU15EG ZU17EG ZU19EG		-3E (0.90V)			
			-2E (0.85V)		-2I (0.85V)	
				-2LE ⁽¹⁾⁽²⁾ (0.85V or 0.72V)		
			-1E (0.85V)		-1I (0.85V)	
					-1LI ⁽²⁾ (0.85V or 0.72V)	
		EV Devices		-3E (0.90V)		
				-2E (0.85V)		-2I (0.85V)
					-2LE ⁽¹⁾⁽²⁾ (0.85V or 0.72V)	
			-1E (0.85V)		-1I (0.85V)	
					-1LI ⁽²⁾ (0.85V or 0.72V)	

Notes:

1. In -2LE speed/temperature grade, devices can operate for a limited time with junction temperature of 110°C. Timing parameters adhere to the same speed file at 110°C as they do below 110°C, regardless of operating voltage (nominal at 0.85V or low voltage at 0.72V). Operation at 110°C Tj is limited to 1% of the device lifetime and can occur sequentially or at regular intervals as long as the total time does not exceed 1% of device lifetime.
2. In Zynq UltraScale+ MPSoCs, when operating the PL at low voltage (0.72V), the PS operates at nominal voltage (0.85V)

The ordering information shown in Figure 3 applies to all packages in the Zynq UltraScale+ MPSoCs.

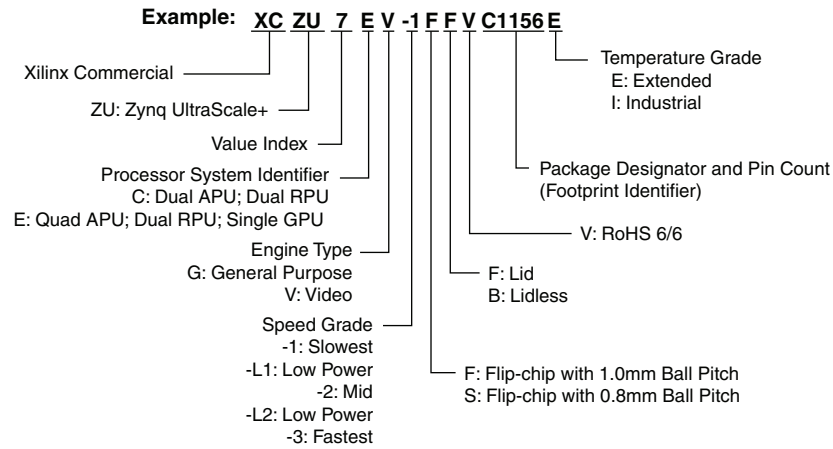

1) -L1 and -L2 are the ordering codes for the low power -1L and -2L speed grades, respectively.

DS891_03_091216

Figure 3: Zynq UltraScale+ MPSoC Ordering Information