



Welcome to [E-XFL.COM](https://www.e-xfl.com)

### **Embedded - System On Chip (SoC): The Heart of Modern Embedded Systems**

**Embedded - System On Chip (SoC)** refers to an integrated circuit that consolidates all the essential components of a computer system into a single chip. This includes a microprocessor, memory, and other peripherals, all packed into one compact and efficient package. SoCs are designed to provide a complete computing solution, optimizing both space and power consumption, making them ideal for a wide range of embedded applications.

### **What are Embedded - System On Chip (SoC)?**

**System On Chip (SoC)** integrates multiple functions of a computer or electronic system onto a single chip. Unlike traditional multi-chip solutions, SoCs combine a central

#### **Details**

Product Status	Active
Architecture	MCU, FPGA
Core Processor	Quad ARM® Cortex®-A53 MPCore™ with CoreSight™, Dual ARM®Cortex™-R5 with CoreSight™, ARM Mali™ -400 MP2
Flash Size	-
RAM Size	256KB
Peripherals	DMA, WDT
Connectivity	CANbus, EBI/EMI, Ethernet, I <sup>2</sup> C, MMC/SD/SDIO, SPI, UART/USART, USB OTG
Speed	533MHz, 600MHz, 1.3GHz
Primary Attributes	Zynq@UltraScale+™ FPGA, 256K+ Logic Cells
Operating Temperature	0°C ~ 100°C (TJ)
Package / Case	900-BBGA, FCBGA
Supplier Device Package	900-FCBGA (31x31)
Purchase URL	<a href="https://www.e-xfl.com/product-detail/xilinx/xczu5ev-2fbvb900e">https://www.e-xfl.com/product-detail/xilinx/xczu5ev-2fbvb900e</a>

## Programmable Logic (PL)

### Configurable Logic Blocks (CLB)

- Look-up tables (LUT)
- Flip-flops
- Cascadable adders

### 36Kb Block RAM

- True dual-port
- Up to 72 bits wide
- Configurable as dual 18Kb

### UltraRAM

- 288Kb dual-port
- 72 bits wide
- Error checking and correction

### DSP Blocks

- 27 x 18 signed multiply
- 48-bit adder/accumulator
- 27-bit pre-adder

### Programmable I/O Blocks

- Supports LVCMOS, LVDS, and SSTL
- 1.0V to 3.3V I/O
- Programmable I/O delay and SerDes

### JTAG Boundary-Scan

- IEEE Std 1149.1 Compatible Test Interface

### PCI Express

- Supports Root complex and End Point configurations
- Supports up to Gen4 speeds
- Up to five integrated blocks in select devices

### 100G Ethernet MAC/PCS

- IEEE Std 802.3 compliant
- CAUI-10 (10x 10.3125Gb/s) or CAUI-4 (4x 25.78125Gb/s)
- RSFEC (IEEE Std 802.3bj) in CAUI-4 configuration
- Up to four integrated blocks in select devices

### Interlaken

- Interlaken spec 1.2 compliant
- 64/67 encoding
- 12 x 12.5Gb/s or 6 x 25Gb/s
- Up to four integrated blocks in select devices

### Video Encoder/Decoder (VCU)

- Available in EV devices
- Accessible from either PS or PL
- Simultaneous encode and decode
- H.264 and H.265 support

### System Monitor in PL

- On-chip voltage and temperature sensing
- 10-bit 200KSPS ADC with up to 17 external inputs

**Table 2: Zynq UltraScale+ MPSoC: CG Device-Package Combinations and Maximum I/Os**

Package (1)(2)(3)(4)(5)	Package Dimensions (mm)	ZU2CG	ZU3CG	ZU4CG	ZU5CG	ZU6CG	ZU7CG	ZU9CG
		HD, HP GTH, GTY	HD, HP GTH, GTY	HD, HP GTH, GTY	HD, HP GTH, GTY	HD, HP GTH, GTY	HD, HP GTH, GTY	HD, HP GTH, GTY
SBVA484 <sup>(6)</sup>	19x19	24, 58 0, 0	24, 58 0, 0					
SFVA625	21x21	24, 156 0, 0	24, 156 0, 0					
SFVC784 <sup>(7)</sup>	23x23	96, 156 0, 0	96, 156 0, 0	96, 156 4, 0	96, 156 4, 0			
FBVB900	31x31			48, 156 16, 0	48, 156 16, 0		48, 156 16, 0	
FFVC900	31x31					48, 156 16, 0		48, 156 16, 0
FFVB1156	35x35					120, 208 24, 0		120, 208 24, 0
FFVC1156	35x35						48, 312 20, 0	
FFVF1517	40x40						48, 416 24, 0	

**Notes:**

1. Go to [Ordering Information](#) for package designation details.
2. FB/FF packages have 1.0mm ball pitch. SB/SF packages have 0.8mm ball pitch.
3. All device package combinations bond out 4 PS-GTR transceivers.
4. All device package combinations bond out 214 PS I/O except ZU2CG and ZU3CG in the SBVA484 and SFVA625 packages, which bond out 170 PS I/Os.
5. Packages with the same last letter and number sequence, e.g., A484, are footprint compatible with all other UltraScale devices with the same sequence. The footprint compatible devices within this family are outlined.
6. All 58 HP I/O pins are powered by the same  $V_{CCO}$  supply.
7. GTH transceivers in the SFVC784 package support data rates up to 12.5Gb/s.

**Table 3: Zynq UltraScale+ MPSoC: EG Device Feature Summary**

	ZU2EG	ZU3EG	ZU4EG	ZU5EG	ZU6EG	ZU7EG	ZU9EG	ZU11EG	ZU15EG	ZU17EG	ZU19EG
Application Processing Unit	Quad-core ARM Cortex-A53 MPCore with CoreSight; NEON & Single/Double Precision Floating Point; 32KB/32KB L1 Cache, 1MB L2 Cache										
Real-Time Processing Unit	Dual-core ARM Cortex-R5 with CoreSight; Single/Double Precision Floating Point; 32KB/32KB L1 Cache, and TCM										
Embedded and External Memory	256KB On-Chip Memory w/ECC; External DDR4; DDR3; DDR3L; LPDDR4; LPDDR3; External Quad-SPI; NAND; eMMC										
General Connectivity	214 PS I/O; UART; CAN; USB 2.0; I2C; SPI; 32b GPIO; Real Time Clock; WatchDog Timers; Triple Timer Counters										
High-Speed Connectivity	4 PS-GTR; PCIe Gen1/2; Serial ATA 3.1; DisplayPort 1.2a; USB 3.0; SGMII										
Graphic Processing Unit	ARM Mali™-400 MP2; 64KB L2 Cache										
System Logic Cells	103,320	154,350	192,150	256,200	469,446	504,000	599,550	653,100	746,550	926,194	1,143,450
CLB Flip-Flops	94,464	141,120	175,680	234,240	429,208	460,800	548,160	597,120	682,560	846,806	1,045,440
CLB LUTs	47,232	70,560	87,840	117,120	214,604	230,400	274,080	298,560	341,280	423,403	522,720
Distributed RAM (Mb)	1.2	1.8	2.6	3.5	6.9	6.2	8.8	9.1	11.3	8.0	9.8
Block RAM Blocks	150	216	128	144	714	312	912	600	744	796	984
Block RAM (Mb)	5.3	7.6	4.5	5.1	25.1	11.0	32.1	21.1	26.2	28.0	34.6
UltraRAM Blocks	0	0	48	64	0	96	0	80	112	102	128
UltraRAM (Mb)	0	0	14.0	18.0	0	27.0	0	22.5	31.5	28.7	36.0
DSP Slices	240	360	728	1,248	1,973	1,728	2,520	2,928	3,528	1,590	1,968
CMTs	3	3	4	4	4	8	4	8	4	11	11
Max. HP I/O <sup>(1)</sup>	156	156	156	156	208	416	208	416	208	572	572
Max. HD I/O <sup>(2)</sup>	96	96	96	96	120	48	120	96	120	96	96
System Monitor	2	2	2	2	2	2	2	2	2	2	2
GTH Transceiver 16.3Gb/s <sup>(3)</sup>	0	0	16	16	24	24	24	32	24	44	44
GTY Transceivers 32.75Gb/s	0	0	0	0	0	0	0	16	0	28	28
Transceiver Fractional PLLs	0	0	8	8	12	12	12	24	12	36	36
PCIe Gen3 x16 and Gen4 x8	0	0	2	2	0	2	0	4	0	4	5
150G Interlaken	0	0	0	0	0	0	0	1	0	2	4
100G Ethernet w/ RS-FEC	0	0	0	0	0	0	0	2	0	2	4

**Notes:**

1. HP = High-performance I/O with support for I/O voltage from 1.0V to 1.8V.
2. HD = High-density I/O with support for I/O voltage from 1.2V to 3.3V.
3. GTH transceivers in the SFVC784 package support data rates up to 12.5Gb/s. See [Table 4](#).

Table 4: Zynq UltraScale+ MPSoC: EG Device-Package Combinations and Maximum I/Os

Package (1)(2)(3)(4)(5)	Package Dimensions (mm)	ZU2EG	ZU3EG	ZU4EG	ZU5EG	ZU6EG	ZU7EG	ZU9EG	ZU11EG	ZU15EG	ZU17EG	ZU19EG
		HD, HP GTH, GTY	HD, HP GTH, GTY	HD, HP GTH, GTY	HD, HP GTH, GTY	HD, HP GTH, GTY	HD, HP GTH, GTY	HD, HP GTH, GTY	HD, HP GTH, GTY	HD, HP GTH, GTY	HD, HP GTH, GTY	HD, HP GTH, GTY
SBVA484(6)	19x19	24, 58 0, 0	24, 58 0, 0									
SFVA625	21x21	24, 156 0, 0	24, 156 0, 0									
SFVC784(7)	23x23	96, 156 0, 0	96, 156 0, 0	96, 156 4, 0	96, 156 4, 0							
FBVB900	31x31			48, 156 16, 0	48, 156 16, 0		48, 156 16, 0					
FFVC900	31x31					48, 156 16, 0		48, 156 16, 0		48, 156 16, 0		
FFVB1156	35x35					120, 208 24, 0		120, 208 24, 0		120, 208 24, 0		
FFVC1156	35x35						48, 312 20, 0		48, 312 20, 0			
FFVB1517	40x40								72, 416 16, 0		72, 572 16, 0	72, 572 16, 0
FFVF1517	40x40						48, 416 24, 0		48, 416 32, 0			
FFVC1760	42.5x42.5								96, 416 32, 16		96, 416 32, 16	96, 416 32, 16
FFVD1760	42.5x42.5										48, 260 44, 28	48, 260 44, 28
FFVE1924	45x45										96, 572 44, 0	96, 572 44, 0

**Notes:**

1. Go to [Ordering Information](#) for package designation details.(5)
2. FB/FF packages have 1.0mm ball pitch. SB/SF packages have 0.8mm ball pitch.
3. All device package combinations bond out 4 PS-GTR transceivers.
4. All device package combinations bond out 214 PS I/O except ZU2EG and ZU3EG in the SBVA484 and SFVA625 packages, which bond out 170 PS I/Os.
5. Packages with the same last letter and number sequence, e.g., A484, are footprint compatible with all other UltraScale devices with the same sequence. The footprint compatible devices within this family are outlined.
6. All 58 HP I/O pins are powered by the same  $V_{CC0}$  supply.
7. GTH transceivers in the SFVC784 package support data rates up to 12.5Gb/s.

**Table 5: Zynq UltraScale+ MPSoC: EV Device Feature Summary**

	ZU4EV	ZU5EV	ZU7EV
Application Processing Unit	Quad-core ARM Cortex-A53 MPCore with CoreSight; NEON & Single/Double Precision Floating Point; 32KB/32KB L1 Cache, 1MB L2 Cache		
Real-Time Processing Unit	Dual-core ARM Cortex-R5 with CoreSight; Single/Double Precision Floating Point; 32KB/32KB L1 Cache, and TCM		
Embedded and External Memory	256KB On-Chip Memory w/ECC; External DDR4; DDR3; DDR3L; LPDDR4; LPDDR3; External Quad-SPI; NAND; eMMC		
General Connectivity	214 PS I/O; UART; CAN; USB 2.0; I2C; SPI; 32b GPIO; Real Time Clock; WatchDog Timers; Triple Timer Counters		
High-Speed Connectivity	4 PS-GTR; PCIe Gen1/2; Serial ATA 3.1; DisplayPort 1.2a; USB 3.0; SGMII		
Graphic Processing Unit	ARM Mali™-400 MP2; 64KB L2 Cache		
Video Codec	1	1	1
System Logic Cells	192,150	256,200	504,000
CLB Flip-Flops	175,680	234,240	460,800
CLB LUTs	87,840	117,120	230,400
Distributed RAM (Mb)	2.6	3.5	6.2
Block RAM Blocks	128	144	312
Block RAM (Mb)	4.5	5.1	11.0
UltraRAM Blocks	48	64	96
UltraRAM (Mb)	14.0	18.0	27.0
DSP Slices	728	1,248	1,728
CMTs	4	4	8
Max. HP I/O <sup>(1)</sup>	156	156	416
Max. HD I/O <sup>(2)</sup>	96	96	48
System Monitor	2	2	2
GTH Transceiver 16.3Gb/s <sup>(3)</sup>	16	16	24
GTY Transceivers 32.75Gb/s	0	0	0
Transceiver Fractional PLLs	8	8	12
PCIe Gen3 x16 and Gen4 x8	2	2	2
150G Interlaken	0	0	0
100G Ethernet w/ RS-FEC	0	0	0

**Notes:**

1. HP = High-performance I/O with support for I/O voltage from 1.0V to 1.8V.
2. HD = High-density I/O with support for I/O voltage from 1.2V to 3.3V.
3. GTH transceivers in the SFVC784 package support data rates up to 12.5Gb/s. See [Table 6](#).

ASIC-class capabilities afforded by the UltraScale MPSoC architecture while supporting rapid system development.

The inclusion of an application processor enables high-level operating system support, e.g., Linux. Other standard operating systems used with the Cortex-A53 processor are also available for the Zynq UltraScale+ MPSoC family. The PS and the PL are on separate power domains, enabling users to power down the PL for power management if required. The processors in the PS always boot first, allowing a software centric approach for PL configuration. PL configuration is managed by software running on the CPU, so it boots similar to an ASSP.

## Xilinx Memory Protection Unit (XMPU)

- Region based memory protection unit
- Up to 16 regions
- Each region supports address alignment of 1MB or 4KB
- Regions can overlap; the higher region number has priority
- Each region can be independently enabled or disabled
- Each region has a start and end address

## Graphics Processing Unit (GPU)

- Supports OpenGL ES 1.1 & 2.0
- Supports OpenVG 1.1
- Operating target frequency: up to 667MHz
- Single Geometry Processor and two Pixel processor
- Pixel Fill Rate: 2 Mpixel/sec/MHz
- Triangle Rate: 0.11 Mtriangles/sec/MHz
- 64KB Level 2 Cache (read-only)
- 4X and 16X Anti-aliasing Support
- ETC1 texture compression to reduce external memory bandwidth
- Extensive texture format support
  - RGBA 8888, 565, 1556
  - Mono 8, 16
  - YUV format support
- Automatic load balancing across different graphics shader engines
- 2D and 3D graphic acceleration
- Up to 4K texture input and 4K render output resolutions
- Each geometry processor and pixel processor supports 4KB page MMU
- Power island gating on each GPU engine and shared cache
- Optional eFUSE disable

## Dynamic Memory Controller (DDRC)

- DDR3, DDR3L, DDR4, LPDDR3, LPDDR4
- Target data rate: Up to 2400Mb/s DDR4 operation in -1 speed grade
- 32-bit and 64-bit bus width support for DDR4, DDR3, DDR3L, or LPDDR3 memories, and 32-bit bus width support for LPDDR4 memory
- ECC support (using extra bits)
- Up to a total DRAM capacity of 32GB



## **SATA**

- Compliant with SATA 3.1 Specification
- SATA host port supports up to 2 external devices
- Compliant with Advanced Host Controller Interface ('AHCI') ver. 1.3
- 1.5Gb/s, 3.0Gb/s, and 6.0Gb/s data rates
- Power management features: supports partial and slumber modes

## **USB 3.0**

- Two USB controllers (configurable as USB 2.0 or USB 3.0)
- Up to 5.0Gb/s data rate
- Host and Device modes
  - Super Speed, High Speed, Full Speed, and Low Speed
  - Up to 12 endpoints
  - The USB host controller registers and data structures are compliant to Intel xHCI specifications
  - 64-bit AXI master port with built-in DMA
  - Power management features: Hibernation mode

## **DisplayPort Controller**

- 4K Display Processing with DisplayPort output
  - Maximum resolution of 4K x 2K-30 (30Hz pixel rate)
  - DisplayPort AUX channel, and Hot Plug Detect (HPD) on the output
  - RGB YCbCr, 4:2:0; 4:2:2, 4:4:4 with 6, 8, 10, and 12b/c
  - Y-only, xvYCC, RGB 4:4:4, YCbCr 4:4:4, YCbCr 4:2:2, and YCbCr 4:2:0 video format with 6,8,10 and 12-bits per color component
  - 256-color palette
  - Multiple frame buffer formats
    - 1, 2, 4, 8 bits per pixel (bpp) via a palette
    - 16, 24, 32bpp
    - Graphics formats such as RGBA8888, RGB555, etc.
- Accepts streaming video from the PL or dedicated DMA controller
- Enables Alpha blending of graphics and Chroma keying

## Configuration Security Unit (CSU)

- Triple redundant Secure Processor Block (SPB) with built-in ECC
- Crypto Interface Block consisting of
  - 256-bit AES-GCM
  - SHA-3/384
  - 4096-bit RSA
- Key Management Unit
- Built-in DMA
- PCAP interface
- Supports ROM validation during pre-configuration stage
- Loads First Stage Boot Loader (FSBL) into OCM in either secure or non-secure boot modes
- Supports voltage, temperature, and frequency monitoring after configuration

## Xilinx Peripheral Protection Unit (XPPU)

- Provides peripheral protection support
- Up to 20 masters simultaneously
- Multiple aperture sizes
- Access control for a specified set of address apertures on a per master basis
- 64KB peripheral apertures and controls access on per peripheral basis

## I/O Peripherals

The IOP unit contains the data communication peripherals. Key features of the IOP include:

### ***Triple-Speed Gigabit Ethernet***

- Compatible with IEEE Std 802.3 and supports 10/100/1000Mb/s transfer rates (Full and Half duplex)
- Supports jumbo frames
- Built-in Scatter-Gather DMA capability
- Statistics counter registers for RMON/MIB
- Multiple I/O types (1.8, 2.5, 3.3V) on RGMII interface with external PHY
- GMII interface to PL to support interfaces as: TBI, SGMII, and RGMII v2.0 support
- Automatic pad and cyclic redundancy check (CRC) generation on transmitted frames
- Transmitter and Receive IP, TCP, and UDP checksum offload
- MDIO interface for physical layer management

- Sleep Mode with automatic wake-up
- Snoop Mode
- 16-bit timestamping for receive messages
- Both internal generated reference clock and external reference clock input from MIO
- Guarantee clock sampling edge between 80 to 83% at 24MHz reference clock input
- Optional eFUSE disable per port

## **USB 2.0**

- Two USB controllers (configurable as USB 2.0 or USB 3.0)
- Host, device and On-The-Go (OTG) modes
- High Speed, Full Speed, and Low Speed
- Up to 12 endpoints
- 8-bit ULPI External PHY Interface
- The USB host controller registers and data structures are compliant to Intel xHCI specifications.
- 64-bit AXI master port with built-in DMA
- Power management features: hibernation mode

## **Static Memory Interfaces**

The static memory interfaces support external static memories.

- ONFI 3.1 NAND flash support with up to 24-bit ECC
- 1-bit SPI, 2-bit SPI, 4-bit SPI (Quad-SPI), or two Quad-SPI (8-bit) serial NOR flash
- 8-bit eMMC interface supporting managed NAND flash

### ***NAND ONFI 3.1 Flash Controller***

- ONFI 3.1 compliant
- Supports chip select reduction per ONFI 3.1 spec
- SLC NAND for boot/configuration and data storage
- ECC options based on SLC NAND
  - 1, 4, or 8 bits per 512+spare bytes
  - 24 bits per 1024+spare bytes
- Maximum throughput as follows
  - Asynchronous mode (SDR) 24.3MB/s
  - Synchronous mode (NV-DDR) 112MB/s (for 100MHz flash clock)
- 8-bit SDR NAND interface

**Table 8: MIO Peripheral Interface Mapping**

Peripheral Interface	MIO	EMIO
Quad-SPI NAND	Yes	No
USB2.0: 0,1	Yes: External PHY	No
SDIO 0,1	Yes	Yes
SPI: 0,1 I2C: 0,1 CAN: 0,1 GPIO	Yes CAN: External PHY GPIO: Up to 78 bits	Yes CAN: External PHY GPIO: Up to 96 bits
GigE: 0,1,2,3	RGMII v2.0: External PHY	Supports GMII, RGMII v2.0 (HSTL), RGMII v1.3, MII, SGMII, and 1000BASE-X in Programmable Logic
UART: 0,1	Simple UART: Only two pins (TX and RX)	Full UART (TX, RX, DTR, DCD, DSR, RI, RTS, and CTS) requires either: <ul style="list-style-type: none"> <li>• Two Processing System (PS) pins (RX and TX) through MIO and six additional Programmable Logic (PL) pins, <i>or</i></li> <li>• Eight Programmable Logic (PL) pins</li> </ul>
Debug Trace Ports	Yes: Up to 16 trace bits	Yes: Up to 32 trace bits
Processor JTAG	Yes	Yes

### ***Transceiver (PS-GTR)***

The four PS-GTR transceivers, which reside in the full power domain (FPD), support data rates of up to 6.0Gb/s. All the protocols cannot be pinned out at the same time. At any given time, four differential pairs can be pinned out using the transceivers. This is user programmable via the high-speed I/O multiplexer (HS-MIO).

- A Quad transceiver PS-GTR (TX/RX pair) able to support following standards simultaneously
  - x1, x2, or x4 lane of PCIe at Gen1 (2.5Gb/s) or Gen2 (5.0Gb/s) rates
  - 1 or 2 lanes of DisplayPort (TX only) at 1.62Gb/s, 2.7Gb/s, or 5.4Gb/s
  - 1 or 2 SATA channels at 1.5Gb/s, 3.0Gb/s, or 6.0Gb/s
  - 1 or 2 USB3.0 channels at 5.0Gb/s
  - 1-4 Ethernet SGMII channels at 1.25Gb/s
- Provides flexible host-programmable multiplexing function for connecting the transceiver resources to the PS masters (DisplayPort, PCIe, Serial-ATA, USB3.0, and GigE).

## HS-MIO

The function of the HS-MIO is to multiplex access from the high-speed PS peripheral to the differential pair on the PS-GTR transceiver as defined in the configuration registers. Up to 4 channels of the transceiver are available for use by the high-speed interfaces in the PS.

Table 9: HS-MIO Peripheral Interface Mapping

Peripheral Interface	Lane0	Lane1	Lane2	Lane3
PCIe (x1, x2 or x4)	PCIe0	PCIe1	PCIe2	PCIe3
SATA (1 or 2 channels)	SATA0	SATA1	SATA0	SATA1
DisplayPort (TX only)	DP1	DPO	DP1	DPO
USB0	USB0	USB0	USB0	–
USB1	–	–	–	USB1
SGMII0	SGMII0	–	–	–
SGMII1	–	SGMII1	–	–
SGMII2	–	–	SGMII2	–
SGMII3	–	–	–	SGMII3

## PS-PL Interface

The PS-PL interface includes:

- AMBA AXI4 interfaces for primary data communication
  - Six 128-bit/64-bit/32-bit High Performance (HP) Slave AXI interfaces from PL to PS.
    - Four 128-bit/64-bit/32-bit HP AXI interfaces from PL to PS DDR.
    - Two 128-bit/64-bit/32-bit high-performance coherent (HPC) ports from PL to cache coherent interconnect (CCI).
  - Two 128-bit/64-bit/32-bit HP Master AXI interfaces from PS to PL.
  - One 128-bit/64-bit/32-bit interface from PL to RPU in PS (PL\_LPD) for low latency access to OCM.
  - One 128-bit/64-bit/32-bit AXI interface from RPU in PS to PL (LPD\_PL) for low latency access to PL.
  - One 128-bit AXI interface (ACP port) for I/O coherent access from PL to Cortex-A53 cache memory. This interface provides coherency in hardware for Cortex-A53 cache memory.
  - One 128-bit AXI interface (ACE Port) for Fully coherent access from PL to Cortex-A53. This interface provides coherency in hardware for Cortex-A53 cache memory and the PL.
- Clocks and resets
  - Four PS clock outputs to the PL with start/stop control.
  - Four PS reset outputs to the PL.

### ***3-State Digitally Controlled Impedance and Low Power I/O Features***

The 3-state Digitally Controlled Impedance (T\_DCI) can control the output drive impedance (series termination) or can provide parallel termination of an input signal to  $V_{CC0}$  or split (Thevenin) termination to  $V_{CC0}/2$ . This allows users to eliminate off-chip termination for signals using T\_DCI. In addition to board space savings, the termination automatically turns off when in output mode or when 3-stated, saving considerable power compared to off-chip termination. The I/Os also have low power modes for IBUF and IDELAY to provide further power savings, especially when used to implement memory interfaces.

## **I/O Logic**

### ***Input and Output Delay***

All inputs and outputs can be configured as either combinatorial or registered. Double data rate (DDR) is supported by all inputs and outputs. Any input or output can be individually delayed by up to 1,250ps of delay with a resolution of 5–15ps. Such delays are implemented as IDELAY and ODELAY. The number of delay steps can be set by configuration and can also be incremented or decremented while in use. The IDELAY and ODELAY can be cascaded together to double the amount of delay in a single direction.

### ***ISERDES and OSERDES***

Many applications combine high-speed, bit-serial I/O with slower parallel operation inside the device. This requires a serializer and deserializer (SerDes) inside the I/O logic. Each I/O pin possesses an IOSERDES (ISERDES and OSERDES) capable of performing serial-to-parallel or parallel-to-serial conversions with programmable widths of 2, 4, or 8 bits. These I/O logic features enable high-performance interfaces, such as Gigabit Ethernet/1000BaseX/SGMII, to be moved from the transceivers to the SelectIO interface.

---

## **High-Speed Serial Transceivers**

Ultra-fast serial data transmission between devices on the same PCB, over backplanes, and across even longer distances is becoming increasingly important for scaling to 100 Gb/s and 400 Gb/s line cards. Specialized dedicated on-chip circuitry and differential I/O capable of coping with the signal integrity issues are required at these high data rates.

Three types of transceivers are used in Zynq UltraScale+ MPSoCs: GTH, GTY, and PS-GTR. All transceivers are arranged in groups of four, known as a transceiver Quad. Each serial transceiver is a combined transmitter and receiver. [Table 10](#) compares the available transceivers.

**Table 10: Transceiver Information**

	<b>Zynq UltraScale+ MPSoCs</b>		
Type	PS-GTR	GTH	GTY
Qty	4	0–44	0–28
Max. Data Rate	6.0Gb/s	16.3Gb/s	32.75Gb/s
Min. Data Rate	1.25Gb/s	0.5Gb/s	0.5Gb/s
Applications	<ul style="list-style-type: none"> <li>• PCIe Gen2</li> <li>• USB</li> <li>• Ethernet</li> </ul>	<ul style="list-style-type: none"> <li>• Backplane</li> <li>• PCIe Gen4</li> <li>• HMC</li> </ul>	<ul style="list-style-type: none"> <li>• 100G+ Optics</li> <li>• Chip-to-Chip</li> <li>• 25G+ Backplane</li> <li>• HMC</li> </ul>

The following information in this section pertains to the GTH and GTY only.

The serial transmitter and receiver are independent circuits that use an advanced phase-locked loop (PLL) architecture to multiply the reference frequency input by certain programmable numbers between 4 and 25 to become the bit-serial data clock. Each transceiver has a large number of user-definable features and parameters. All of these can be defined during device configuration, and many can also be modified during operation.

## Transmitter

The transmitter is fundamentally a parallel-to-serial converter with a conversion ratio of 16, 20, 32, 40, 64, or 80 for the GTH and 16, 20, 32, 40, 64, 80, 128, or 160 for the GTY. This allows the designer to trade off datapath width against timing margin in high-performance designs. These transmitter outputs drive the PC board with a single-channel differential output signal. TXOUTCLK is the appropriately divided serial data clock and can be used directly to register the parallel data coming from the internal logic. The incoming parallel data is fed through an optional FIFO and has additional hardware support for the 8B/10B, 64B/66B, or 64B/67B encoding schemes to provide a sufficient number of transitions. The bit-serial output signal drives two package pins with differential signals. This output signal pair has programmable signal swing as well as programmable pre- and post-emphasis to compensate for PC board losses and other interconnect characteristics. For shorter channels, the swing can be reduced to reduce power consumption.

## Receiver

The receiver is fundamentally a serial-to-parallel converter, changing the incoming bit-serial differential signal into a parallel stream of words, each 16, 20, 32, 40, 64, or 80 bits in the GTH or 16, 20, 32, 40, 64, 80, 128, or 160 for the GTY. This allows the designer to trade off internal datapath width against logic timing margin. The receiver takes the incoming differential data stream, feeds it through programmable DC automatic gain control, linear and decision feedback equalizers (to compensate for PC board, cable, optical and other interconnect characteristics), and uses the reference clock input to initiate clock recognition. There is no need for a separate clock line. The data pattern uses non-return-to-zero (NRZ) encoding and optionally ensures sufficient data transitions by using the selected encoding scheme. Parallel data is then transferred into the device logic using the RXUSRCLK clock. For short channels, the transceivers offer a special low-power mode (LPM) to reduce power consumption by approximately 30%. The receiver DC automatic gain control and linear and decision feedback equalizers can optionally “auto-adapt” to automatically learn and compensate for different interconnect characteristics. This enables even more margin for tough 10G+ and 25G+ backplanes.

## Out-of-Band Signaling

The transceivers provide out-of-band (OOB) signaling, often used to send low-speed signals from the transmitter to the receiver while high-speed serial data transmission is not active. This is typically done when the link is in a powered-down state or has not yet been initialized. This benefits PCIe and SATA/SAS and QPI applications.

---

## Integrated Interface Blocks for PCI Express Designs

The MPSoC PL includes integrated blocks for PCIe technology that can be configured as an Endpoint or Root Port, compliant to the PCI Express Base Specification Revision 3.1 for Gen3 and lower data rates and compatible with the PCI Express Base Specification Revision 4.0 (rev 0.5) for Gen4 data rates. The Root Port can be used to build the basis for a compatible Root Complex, to allow custom chip-to-chip communication via the PCI Express protocol, and to attach ASSP Endpoint devices, such as Ethernet Controllers or Fibre Channel HBAs, to the MPSoC.

This block is highly configurable to system design requirements and can operate 1, 2, 4, 8, or 16 lanes at up to 2.5Gb/s, 5.0Gb/s, 8.0Gb/s, or 16Gb/s data rates. For high-performance applications, advanced buffering techniques of the block offer a flexible maximum payload size of up to 1,024 bytes. The integrated block interfaces to the integrated high-speed transceivers for serial connectivity and to block RAMs for data buffering. Combined, these elements implement the Physical Layer, Data Link Layer, and Transaction Layer of the PCI Express protocol.

Xilinx provides a light-weight, configurable, easy-to-use LogiCORE™ IP wrapper that ties the various building blocks (the integrated block for PCIe, the transceivers, block RAM, and clocking resources) into an Endpoint or Root Port solution. The system designer has control over many configurable parameters: link width and speed, maximum payload size, MPSoC logic interface speeds, reference clock frequency, and base address register decoding and filtering.

---

## Integrated Block for Interlaken

Some UltraScale architecture-based devices include integrated blocks for Interlaken. Interlaken is a scalable chip-to-chip interconnect protocol designed to enable transmission speeds from 10Gb/s to 150Gb/s. The Interlaken integrated block in the UltraScale architecture is compliant to revision 1.2 of the Interlaken specification with data striping and de-striping across 1 to 12 lanes. Permitted configurations are: 1 to 12 lanes at up to 12.5Gb/s and 1 to 6 lanes at up to 25.78125Gb/s, enabling flexible support for up to 150Gb/s per integrated block. With multiple Interlaken blocks, certain UltraScale architecture-based devices enable easy, reliable Interlaken switches and bridges.



## Programmable Data Width

Each port can be configured as  $32K \times 1$ ;  $16K \times 2$ ;  $8K \times 4$ ;  $4K \times 9$  (or 8);  $2K \times 18$  (or 16);  $1K \times 36$  (or 32); or  $512 \times 72$  (or 64). Whether configured as block RAM or FIFO, the two ports can have different aspect ratios without any constraints. Each block RAM can be divided into two completely independent 18Kb block RAMs that can each be configured to any aspect ratio from  $16K \times 1$  to  $512 \times 36$ . Everything described previously for the full 36Kb block RAM also applies to each of the smaller 18Kb block RAMs. Only in simple dual-port (SDP) mode can data widths of greater than 18 bits (18Kb RAM) or 36 bits (36Kb RAM) be accessed. In this mode, one port is dedicated to read operation, the other to write operation. In SDP mode, one side (read or write) can be variable, while the other is fixed to 32/36 or 64/72. Both sides of the dual-port 36Kb RAM can be of variable width.

## Error Detection and Correction

Each 64-bit-wide block RAM can generate, store, and utilize eight additional Hamming code bits and perform single-bit error correction and double-bit error detection (ECC) during the read process. The ECC logic can also be used when writing to or reading from external 64- to 72-bit-wide memories.

## FIFO Controller

Each block RAM can be configured as a 36Kb FIFO or an 18Kb FIFO. The built-in FIFO controller for single-clock (synchronous) or dual-clock (asynchronous or multirate) operation increments the internal addresses and provides four handshaking flags: full, empty, programmable full, and programmable empty. The programmable flags allow the user to specify the FIFO counter values that make these flags go active. The FIFO width and depth are programmable with support for different read port and write port widths on a single FIFO. A dedicated cascade path allows for easy creation of deeper FIFOs.

---

## UltraRAM

UltraRAM is a high-density, dual-port, synchronous memory block used in some UltraScale+ families. Both of the ports share the same clock and can address all of the  $4K \times 72$  bits. Each port can independently read from or write to the memory array. UltraRAM supports two types of write enable schemes. The first mode is consistent with the block RAM byte write enable mode. The second mode allows gating the data and parity byte writes separately. Multiple UltraRAM blocks can be cascaded together to create larger memory arrays. UltraRAM blocks can be connected together to create larger memory arrays. Dedicated routing in the UltraRAM column enables the entire column height to be connected together. This makes UltraRAM an ideal solution for replacing external memories such as SRAM. Cascadable anywhere from 288Kb to 36Mb, UltraRAM provides the flexibility to fulfill many different memory requirements.

## Error Detection and Correction

Each 64-bit-wide UltraRAM can generate, store and utilize eight additional Hamming code bits and perform single-bit error correction and double-bit error detection (ECC) during the read process.

## Digital Signal Processing

DSP applications use many binary multipliers and accumulators, best implemented in dedicated DSP slices. All UltraScale architecture-based devices have many dedicated, low-power DSP slices, combining high speed with small size while retaining system design flexibility.

Each DSP slice fundamentally consists of a dedicated  $27 \times 18$  bit twos complement multiplier and a 48-bit accumulator. The multiplier can be dynamically bypassed, and two 48-bit inputs can feed a single-instruction-multiple-data (SIMD) arithmetic unit (dual 24-bit add/subtract/accumulate or quad 12-bit add/subtract/accumulate), or a logic unit that can generate any one of ten different logic functions of the two operands.

The DSP includes an additional pre-adder, typically used in symmetrical filters. This pre-adder improves performance in densely packed designs and reduces the DSP slice count by up to 50%. The 96-bit-wide XOR function, programmable to 12, 24, 48, or 96-bit widths, enables performance improvements when implementing forward error correction and cyclic redundancy checking algorithms.

The DSP also includes a 48-bit-wide pattern detector that can be used for convergent or symmetric rounding. The pattern detector is also capable of implementing 96-bit-wide logic functions when used in conjunction with the logic unit.

The DSP slice provides extensive pipelining and extension capabilities that enhance the speed and efficiency of many applications beyond digital signal processing, such as wide dynamic bus shifters, memory address generators, wide bus multiplexers, and memory-mapped I/O register files. The accumulator can also be used as a synchronous up/down counter.

## System Monitor

The System Monitor blocks in the UltraScale architecture are used to enhance the overall safety, security, and reliability of the system by monitoring the physical environment via on-chip power supply and temperature sensors.

All UltraScale architecture-based devices contain at least one System Monitor. The System Monitor in UltraScale+ devices is similar to the Kintex UltraScale and Virtex UltraScale devices but with the addition of a PMBus interface.

Zynq UltraScale+ MPSoCs contain one System Monitor in the PL and an additional block in the PS. The System Monitor in the PL has the same features as the block in UltraScale+ FPGAs. See [Table 11](#).

*Table 11: Key System Monitor Features*

	Zynq UltraScale+ MPSoC PL	Zynq UltraScale+ MPSoC PS
ADC	10-bit 200kSPS	10-bit 1MSPS
Interfaces	JTAG, I2C, DRP, PMBus	APB

In FPGAs and the MPSoC PL, sensor outputs and up to 17 user-allocated external analog inputs are digitized using a 10-bit 200 kilo-sample-per-second (kSPS) ADC, and the measurements are stored in registers that can be accessed via internal FPGA (DRP), JTAG, PMBus, or I2C interfaces. The I2C interface and PMBus allow the on-chip monitoring to be easily accessed by the System Manager/Host before and after device configuration.

The System Monitor in the MPSoC PS uses a 10-bit, 1 mega-sample-per-second (MSPS) ADC to digitize the sensor inputs. The measurements are stored in registers and are accessed via the Advanced Peripheral Bus (APB) interface by the processors and the PMU in the PS.

---

## Packaging

The UltraScale architecture-based devices are available in a variety of organic flip-chip and lidless flip-chip packages supporting different quantities of I/Os and transceivers. Maximum supported performance can depend on the style of package and its material. Always refer to the specific device data sheet for performance specifications by package type.

In flip-chip packages, the silicon device is attached to the package substrate using a high-performance flip-chip process. Decoupling capacitors are mounted on the package substrate to optimize signal integrity under simultaneous switching of outputs (SSO) conditions.

---

## System-Level Features

Several functions span both the PS and PL and include:

- Reset Management
- Clock Management
- Power Domains
- PS Boot and Device Configuration
- Hardware and Software Debug Support

### Reset Management

The reset management function provides the ability to reset the entire device or individual units within it. The PS supports these reset functions and signals:

- External and internal power-on reset signal
- Warm reset
- Watchdog timer reset
- User resets to PL
- Software, watchdog timer, or JTAG provided resets
- Security violation reset (locked down reset)

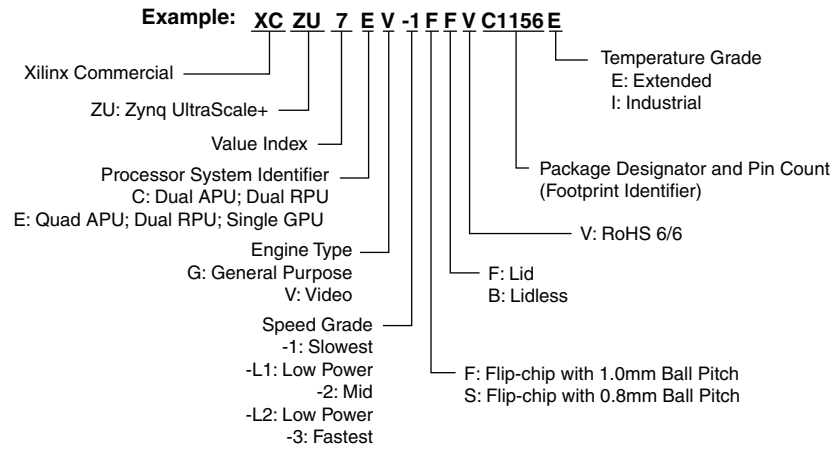

1) -L1 and -L2 are the ordering codes for the low power -1L and -2L speed grades, respectively.

DS891\_03\_091216

Figure 3: Zynq UltraScale+ MPSoC Ordering Information

## Revision History

The following table shows the revision history for this document:

Date	Version	Description of Revisions
02/15/2017	1.4	Updated DSP count in <a href="#">Table 1</a> , <a href="#">Table 3</a> , and <a href="#">Table 5</a> . Updated <a href="#">I/O Electrical Characteristics</a> . Updated <a href="#">Table 12</a> with -2E speed grade.
09/23/2016	1.3	Updated <a href="#">Table 2</a> ; <a href="#">Table 3</a> ; <a href="#">Table 4</a> ; <a href="#">Table 6</a> ; <a href="#">Graphics Processing Unit (GPU)</a> ; and <a href="#">NAND ONFI 3.1 Flash Controller</a> .
06/03/2016	1.2	Added CG devices: Updated <a href="#">Table 1</a> ; <a href="#">Table 2</a> ; <a href="#">Table 3</a> ; <a href="#">Table 4</a> ; <a href="#">Table 5</a> ; <a href="#">Table 6</a> ; and <a href="#">Table 12</a> . Added <a href="#">Video Encoder/Decoder (VCU)</a> ; <a href="#">Table 7</a> ; and <a href="#">Power Examples</a> (removed XPE Computed Range table). Updated: <a href="#">General Description</a> ; <a href="#">ARM Cortex-A53 Based Application Processing Unit (APU)</a> ; <a href="#">Zynq UltraScale+ MPSoCs</a> ; <a href="#">Dynamic Memory Controller (DDRC)</a> ; and <a href="#">Figure 3</a> .
01/28/2016	1.1	Updated <a href="#">Table 1</a> and <a href="#">Table 2</a> .
11/24/2015	1.0	Initial Xilinx release.

## Disclaimer

The information disclosed to you hereunder (the "Materials") is provided solely for the selection and use of Xilinx products. To the maximum extent permitted by applicable law: (1) Materials are made available "AS IS" and with all faults, Xilinx hereby DISCLAIMS ALL WARRANTIES AND CONDITIONS, EXPRESS, IMPLIED, OR STATUTORY, INCLUDING BUT NOT LIMITED TO WARRANTIES OF MERCHANTABILITY, NON-INFRINGEMENT, OR FITNESS FOR ANY PARTICULAR PURPOSE; and (2) Xilinx shall not be liable (whether in contract or tort, including negligence, or under any other theory of liability) for any loss or damage of any kind or nature related to, arising under, or in connection with, the Materials (including your use of the Materials), including for any direct, indirect, special, incidental, or consequential loss or damage (including loss of data, profits, goodwill, or any type of loss or damage suffered as a result of any action brought by a third party) even if such damage or loss was reasonably foreseeable or Xilinx had been advised of the possibility of the same. Xilinx assumes no obligation to correct any errors contained in the Materials or to notify you of updates to the Materials or to product specifications. You may not reproduce, modify, distribute, or publicly display the Materials without prior written consent. Certain products are subject to the terms and conditions of Xilinx's limited warranty, please refer to Xilinx's Terms of Sale which can be viewed at <http://www.xilinx.com/legal.htm#tos>; IP cores may be subject to warranty and support terms contained in a license issued to you by Xilinx. Xilinx products are not designed or intended to be fail-safe or for use in any application requiring fail-safe performance; you assume sole risk and liability for use of Xilinx products in such critical applications, please refer to Xilinx's Terms of Sale which can be viewed at <http://www.xilinx.com/legal.htm#tos>.

This document contains preliminary information and is subject to change without notice. Information provided herein relates to products and/or services not yet available for sale, and provided solely for information purposes and are not intended, or to be construed, as an offer for sale or an attempted commercialization of the products and/or services referred to herein.

## Automotive Applications Disclaimer

AUTOMOTIVE PRODUCTS (IDENTIFIED AS "XA" IN THE PART NUMBER) ARE NOT WARRANTED FOR USE IN THE DEPLOYMENT OF AIRBAGS OR FOR USE IN APPLICATIONS THAT AFFECT CONTROL OF A VEHICLE ("SAFETY APPLICATION") UNLESS THERE IS A SAFETY CONCEPT OR REDUNDANCY FEATURE CONSISTENT WITH THE ISO 26262 AUTOMOTIVE SAFETY STANDARD ("SAFETY DESIGN"). CUSTOMER SHALL, PRIOR TO USING OR DISTRIBUTING ANY SYSTEMS THAT INCORPORATE PRODUCTS, THOROUGHLY TEST SUCH SYSTEMS FOR SAFETY PURPOSES. USE OF PRODUCTS IN A SAFETY APPLICATION WITHOUT A SAFETY DESIGN IS FULLY AT THE RISK OF CUSTOMER, SUBJECT ONLY TO APPLICABLE LAWS AND REGULATIONS GOVERNING LIMITATIONS ON PRODUCT LIABILITY.