



Welcome to [E-XFL.COM](https://www.e-xfl.com)

Embedded - Microcontrollers - Application Specific: Tailored Solutions for Precision and Performance

Embedded - Microcontrollers - Application Specific represents a category of microcontrollers designed with unique features and capabilities tailored to specific application needs. Unlike general-purpose microcontrollers, application-specific microcontrollers are optimized for particular tasks, offering enhanced performance, efficiency, and functionality to meet the demands of specialized applications.

What Are Embedded - Microcontrollers - Application Specific?

Application specific microcontrollers are engineered to

Details

Product Status	Obsolete
Applications	Wireless Audio
Core Processor	8052
Program Memory Type	FLASH
Controller Series	-
RAM Size	-
Interface	-
Number of I/O	-
Voltage - Supply	-
Operating Temperature	-
Mounting Type	-
Package / Case	-
Supplier Device Package	-
Purchase URL	https://www.e-xfl.com/product-detail/microchip-technology/darr84-apk

DARR84 Wireless Audio Processor

Highly-Integrated, Multi-Application, Tri-Band (2.4, 5.2 and 5.8 GHz) Audio Processor

Summary

The DARR84 is a highly-integrated wireless audio processor which extends Microchip's KlearNet™ technology interoperability. The fundamental core of the DARR84 is derived from the very popular and successful DARR83 processor. The DARR84 integrates a 16-bit audio DAC plus headphone amplifier, as well as an analog audio input, including ADC and microphone amplifier to reduce overall solution costs. The DARR84 runs on two AAA batteries and headphones and headsets. Target applications include gaming, VOIP and high-end audio devices. Microchip's DARR84 supports multiple RF bands and frequencies within each RF band (2.4, 5.2 and 5.8 GHz) and incorporates Wireless DNA technology which effectively manages common interference sources such as Wi-Fi®, Bluetooth® and microwave ovens, among others. The DARR84 also has an integrated SRC, making it easy to support multiple audio sampling rates.



Highlights

- Highly-integrated wireless audio processor
- 16-bit HD stereo DAC, including headphone amplifier
- 16-bit mono ADC, including microphone amplifier
- Up to two uncompressed stereo audio channels
- Bi-directional audio support, allowing simultaneous Rx and Tx on a single device
- Supports operation via charging circuit or two AAA batteries
- Higher integration supports smaller speaker and headset reference designs
- Antenna diversity algorithms in the baseband processor minimize fading and multi-path effects
- Complete KlearNet technology compatibility enables easy connectivity to other KlearNet technology devices
- Configurable, low latency enables simple Dolby® certification

Target Applications

- Wireless headphones
- Wireless headsets
- Wireless soundbars and sub-woofers
- Gaming and VOIP headsets
- Wireless microphones
- Wireless speakers
- Battery-powered speakers

Key Features	Benefits
Wireless DNA technology	Reduces interference commonly associated with other RF devices such as Wi-Fi®, Bluetooth®, microwave ovens and DECT phones
Supports point to multi-point audio	Allows multiple receivers to listen to same audio stream
Supports antenna diversity algorithms	Required to support robust wireless link and audio performance
Well-suited for stereo and surround speakers	Allows the user to place speakers anywhere in the room while enjoying clear, interference-free, HD DVD quality audio
16-bit HD stereo DAC and headphone amplifier	Reduces BOM cost and size of headphone/headset solutions, without compromising audio quality
16-bit mono ADC and microphone amplifier	Well-suited for voice-enabled headsets
Uncompressed, bit-true audio transmissions	Zero impact on quality under normal wireless conditions
Low-latency audio transfer; default at <20 ms	Complies with Dolby certification requirements
Integrated 8052 MCU	Enables KlearNet™ audio networking technology, without compromising solution cost and size



MICROCHIP

What is KlearNet Technology?

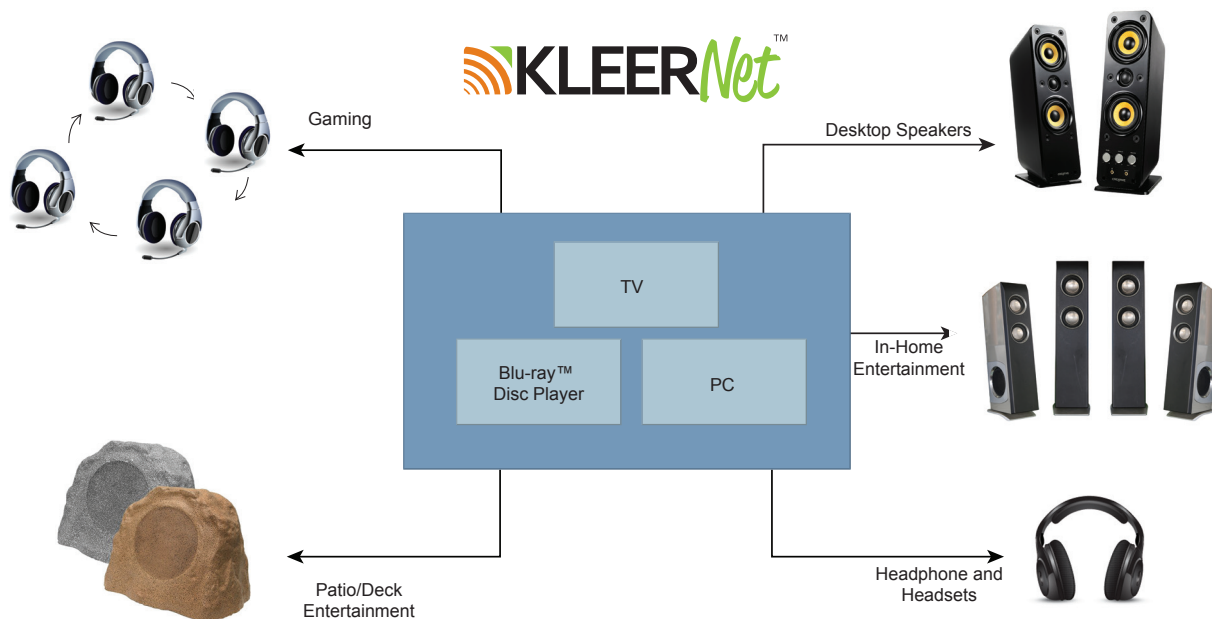

- Open interoperability with multiple consumer electronics brands
- High-quality, wireless audio streaming from content-rich sources such as PC, TV and mobile platforms
- Higher quality audio streaming compared to Bluetooth and Wi-Fi
- Robust link and automatic network configuration for ease of use

DARR84-based KlearNet Technology Headset Reference Block Diagram

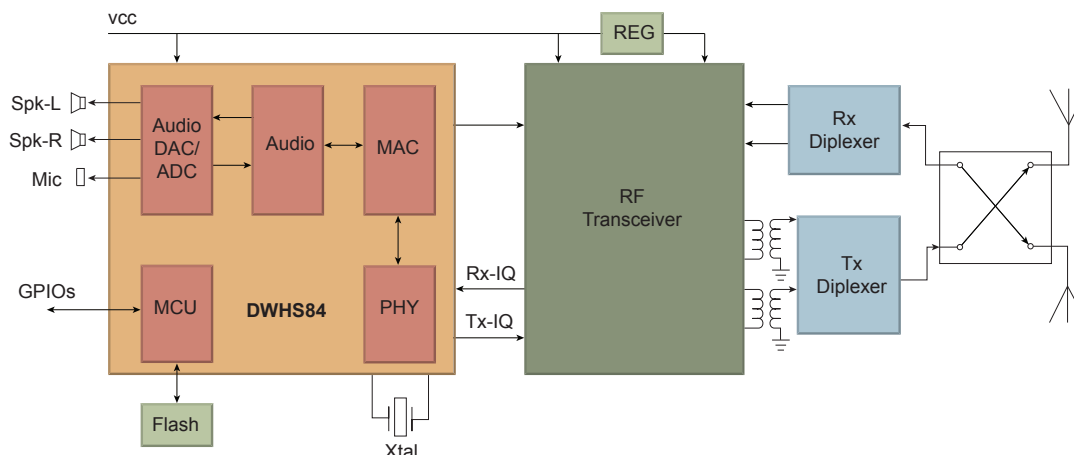

MICROCHIP

www.microchip.com/wirelessaudio

Visit our web site for additional product information and to locate your local sales office.

Microchip Technology Inc. • 2355 W. Chandler Blvd. • Chandler, AZ 85224-6199

Microcontrollers • Digital Signal Controllers • Analog • Memory • Wireless