

Welcome to E-XFL.COM

Understanding Embedded - CPLDs (Complex Programmable Logic Devices)

Embedded - CPLDs, or Complex Programmable Logic Devices, are highly versatile digital logic devices used in electronic systems. These programmable components are designed to perform complex logical operations and can be customized for specific applications. Unlike fixed-function ICs, CPLDs offer the flexibility to reprogram their configuration, making them an ideal choice for various embedded systems. They consist of a set of logic gates and programmable interconnects, allowing designers to implement complex logic circuits without needing custom hardware.

Applications of Embedded - CPLDs

Details

Product Status	Active
Programmable Type	In System Programmable
Delay Time tpd(1) Max	5 ns
Voltage Supply - Internal	1.7V ~ 1.9V
Number of Logic Elements/Blocks	2
Number of Macrocells	32
Number of Gates	-
Number of I/O	32
Operating Temperature	0°C ~ 90°C (TJ)
Mounting Type	Surface Mount
Package / Case	48-LQFP
Supplier Device Package	48-TQFP (7x7)
Purchase URL	https://www.e-xfl.com/product-detail/lattice-semiconductor/lc4032zc-5tn48c

Figure 3. AND Array

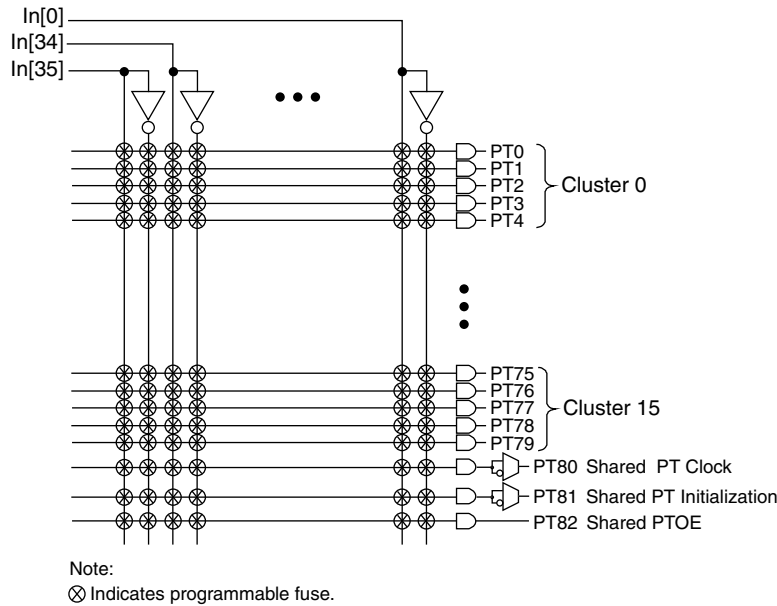

Enhanced Logic Allocator

Within the logic allocator, product terms are allocated to macrocells in product term clusters. Each product term cluster is associated with a macrocell. The cluster size for the ispMACH 4000 family is 4+1 (total 5) product terms. The software automatically considers the availability and distribution of product term clusters as it fits the functions within a GLB. The logic allocator is designed to provide three speed paths: 5-PT fast bypass path, 20-PT Speed Locking path and an up to 80-PT path. The availability of these three paths lets designers trade timing variability for increased performance.

The enhanced Logic Allocator of the ispMACH 4000 family consists of the following blocks:

- Product Term Allocator
- Cluster Allocator
- Wide Steering Logic

Figure 4 shows a macrocell slice of the Logic Allocator. There are 16 such slices in the GLB.

Figure 4. Macrocell Slice

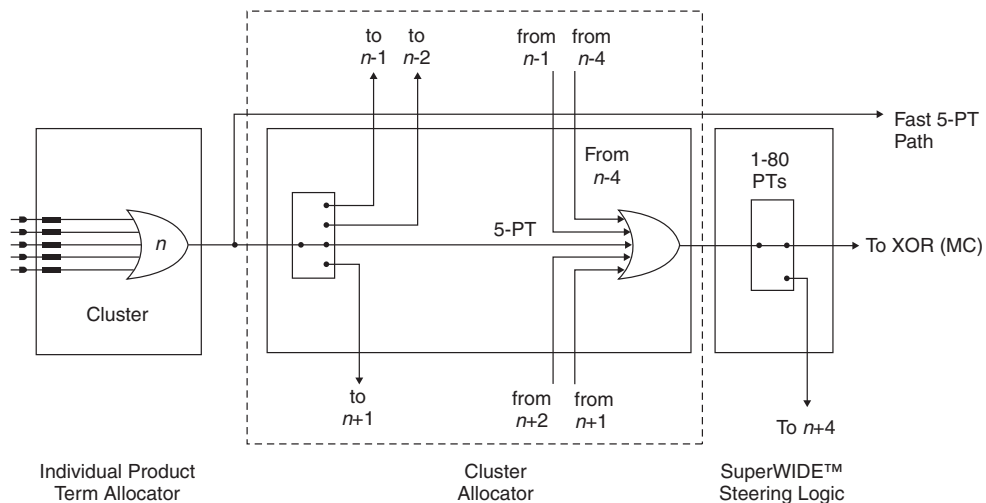

- LVTTTL
- LVC MOS 3.3
- LVC MOS 2.5
- LVC MOS 1.8
- 3.3V PCI Compatible

All of the I/Os and dedicated inputs have the capability to provide a bus-keeper latch, Pull-up Resistor or Pull-down Resistor. A fourth option is to provide none of these. The selection is done on a global basis. The default in both hardware and software is such that when the device is erased or if the user does not specify, the input structure is configured to be a Pull-up Resistor.

Each ispMACH 4000 device I/O has an individually programmable output slew rate control bit. Each output can be individually configured for fast slew or slow slew. The typical edge rate difference between fast and slow slew setting is 20%. For high-speed designs with long, unterminated traces, the slow-slew rate will introduce fewer reflections, less noise and keep ground bounce to a minimum. For designs with short traces or well terminated lines, the fast slew rate can be used to achieve the highest speed.

Global OE Generation

Most ispMACH 4000 family devices have a 4-bit wide Global OE Bus, except the ispMACH 4032 device that has a 2-bit wide Global OE Bus. This bus is derived from a 4-bit internal global OE PT bus and two dual purpose I/O or GOE pins. Each signal that drives the bus can optionally be inverted.

Each GLB has a block-level OE PT that connects to all bits of the Global OE PT bus with four fuses. Hence, for a 256-macrocell device (with 16 blocks), each line of the bus is driven from 16 OE product terms. Figures 9 and 10 show a graphical representation of the global OE generation.

Figure 9. Global OE Generation for All Devices Except ispMACH 4032

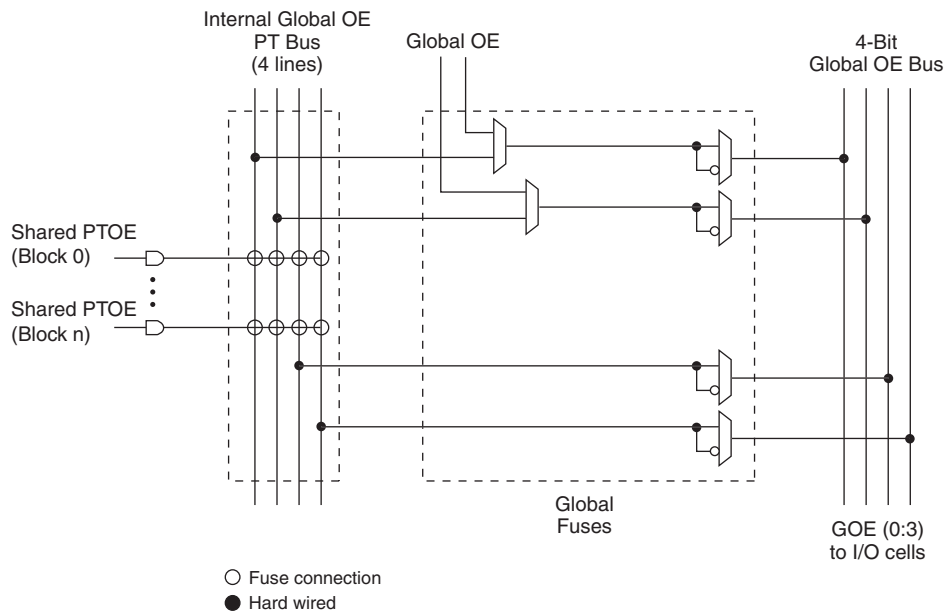

IEEE 1532-Compliant In-System Programming

Programming devices in-system provides a number of significant benefits including: rapid prototyping, lower inventory levels, higher quality and the ability to make in-field modifications. All ispMACH 4000 devices provide In-System Programming (ISP™) capability through the Boundary Scan Test Access Port. This capability has been implemented in a manner that ensures that the port remains compliant to the IEEE 1149.1 standard. By using IEEE 1149.1 as the communication interface through which ISP is achieved, users get the benefit of a standard, well-defined interface. All ispMACH 4000 devices are also compliant with the IEEE 1532 standard.

The ispMACH 4000 devices can be programmed across the commercial temperature and voltage range. The PC-based Lattice software facilitates in-system programming of ispMACH 4000 devices. The software takes the JEDEC file output produced by the design implementation software, along with information about the scan chain, and creates a set of vectors used to drive the scan chain. The software can use these vectors to drive a scan chain via the parallel port of a PC. Alternatively, the software can output files in formats understood by common automated test equipment. This equipment can then be used to program ispMACH 4000 devices during the testing of a circuit board.

User Electronic Signature

The User Electronic Signature (UES) allows the designer to include identification bits or serial numbers inside the device, stored in E²CMOS memory. The ispMACH 4000 device contains 32 UES bits that can be configured by the user to store unique data such as ID codes, revision numbers or inventory control codes.

Security Bit

A programmable security bit is provided on the ispMACH 4000 devices as a deterrent to unauthorized copying of the array configuration patterns. Once programmed, this bit defeats readback of the programmed pattern by a device programmer, securing proprietary designs from competitors. Programming and verification are also defeated by the security bit. The bit can only be reset by erasing the entire device.

Hot Socketing

The ispMACH 4000 devices are well-suited for applications that require hot socketing capability. Hot socketing a device requires that the device, during power-up and down, can tolerate active signals on the I/Os and inputs without being damaged. Additionally, it requires that the effects of I/O pin loading be minimal on active signals. The ispMACH 4000 devices provide this capability for input voltages in the range 0V to 3.0V.

Density Migration

The ispMACH 4000 family has been designed to ensure that different density devices in the same package have the same pin-out. Furthermore, the architecture ensures a high success rate when performing design migration from lower density parts to higher density parts. In many cases, it is possible to shift a lower utilization design targeted for a high density device to a lower density device. However, the exact details of the final resource utilization will impact the likely success in each case.

Supply Current, ispMACH 4000Z (Cont.)

Over Recommended Operating Conditions

Symbol	Parameter	Condition	Min.	Typ.	Max.	Units
ispMACH 4256ZC						
ICC ^{1,2,3,5}	Operating Power Supply Current	V _{CC} = 1.8V, T _A = 25°C	—	341	—	μA
		V _{CC} = 1.9V, T _A = 70°C	—	361	—	μA
		V _{CC} = 1.9V, T _A = 85°C	—	372	—	μA
		V _{CC} = 1.9V, T _A = 125°C	—	468	—	μA
ICC ^{4,5}	Standby Power Supply Current	V _{CC} = 1.8V, T _A = 25°C	—	13	—	μA
		V _{CC} = 1.9V, T _A = 70°C	—	32	55	μA
		V _{CC} = 1.9V, T _A = 85°C	—	43	90	μA
		V _{CC} = 1.9V, T _A = 125°C	—	135	—	μA

1. T_A = 25°C, frequency = 1.0 MHz.

2. Device configured with 16-bit counters.

3. I_{CC} varies with specific device configuration and operating frequency.

4. V_{CCO} = 3.6V, V_{IN} = 0V or V_{CCO}, bus maintenance turned off. V_{IN} above V_{CCO} will add transient current above the specified standby I_{CC}.

5. Includes V_{CCO} current without output loading.

ispMACH 4000Z Internal Timing Parameters (Cont.)

Over Recommended Operating Conditions

Parameter	Description	-45		-5		-75		Units
		Min.	Max.	Min.	Max.	Min.	Max.	
t _{P_{TOE}}	Macrocell PT OE Delay	—	2.50	—	2.70	—	2.00	ns

Note: Internal Timing Parameters are not tested and are for reference only. Refer to the timing model in this data sheet for further details. Timing v.2.2

Boundary Scan Waveforms and Timing Specifications

Symbol	Parameter	Min.	Max.	Units
t_{BTCP}	TCK [BSCAN test] clock cycle	40	—	ns
t_{BTCH}	TCK [BSCAN test] pulse width high	20	—	ns
t_{BTCL}	TCK [BSCAN test] pulse width low	20	—	ns
t_{BTSU}	TCK [BSCAN test] setup time	8	—	ns
t_{BTH}	TCK [BSCAN test] hold time	10	—	ns
t_{BRF}	TCK [BSCAN test] rise and fall time	50	—	mV/ns
t_{BTCO}	TAP controller falling edge of clock to valid output	—	10	ns
t_{BTOZ}	TAP controller falling edge of clock to data output disable	—	10	ns
t_{BTVO}	TAP controller falling edge of clock to data output enable	—	10	ns
t_{BTCPSU}	BSCAN test Capture register setup time	8	—	ns
t_{BTCPH}	BSCAN test Capture register hold time	10	—	ns
t_{BTUCO}	BSCAN test Update reg, falling edge of clock to valid output	—	25	ns
t_{BTUOZ}	BSCAN test Update reg, falling edge of clock to output disable	—	25	ns
t_{BTUOV}	BSCAN test Update reg, falling edge of clock to output enable	—	25	ns

Power Consumption



Note: The devices are configured with maximum number of 16-bit counters, typical current at 1.8V, 25°C.



Note: The devices are configured with maximum number of 16-bit counters, typical current at 1.8V, 25°C.



Note: The devices are configured with maximum number of 16-bit counters, typical current at 3.3V, 2.5V, 25°C.

Power Estimation Coefficients¹

Device	A	B
ispMACH 4032V/B	11.3	0.010
ispMACH 4032C	1.3	0.010
ispMACH 4064V/B	11.5	0.010
ispMACH 4064C	1.5	0.010
ispMACH 4128V/B	11.5	0.011
ispMACH 4128C	1.5	0.011
ispMACH 4256V/B	12	0.011
ispMACH 4256C	2	0.011
ispMACH 4384V/B	12.5	0.013
ispMACH 4384C	2.5	0.013
ispMACH 4512V/B	13	0.013
ispMACH 4512C	3	0.013
ispMACH 4032ZC	0.010	0.010
ispMACH 4064ZC	0.011	0.010
ispMACH 4128ZC	0.012	0.010
ispMACH 4256ZC	0.013	0.010

1. For further information about the use of these coefficients, refer to TN1005, [Power Estimation in ispMACH 4000V/B/C/Z Devices](#).

**ispMACH 4032V/B/C and 4064V/B/C Logic Signal Connections:
44-Pin TQFP**

Pin Number	Bank Number	ispMACH 4032V/B/C		ispMACH 4064V/B/C	
		GLB/MC/Pad	ORP	GLB/MC/Pad	ORP
1	-	TDI	-	TDI	-
2	0	A5	A^5	A10	A^5
3	0	A6	A^6	A12	A^6
4	0	A7	A^7	A14	A^7
5	0	GND (Bank 0)	-	GND (Bank 0)	-
6	0	VCCO (Bank 0)	-	VCCO (Bank 0)	-
7	0	A8	A^8	B0	B^0
8	0	A9	A^9	B2	B^1
9	0	A10	A^10	B4	B^2
10	-	TCK	-	TCK	-
11	-	VCC	-	VCC	-
12	-	GND	-	GND	-
13	0	A12	A^12	B8	B^4
14	0	A13	A^13	B10	B^5
15	0	A14	A^14	B12	B^6
16	0	A15	A^15	B14	B^7
17	1	CLK2/I	-	CLK2/I	-
18	1	B0	B^0	C0	C^0
19	1	B1	B^1	C2	C^1
20	1	B2	B^2	C4	C^2
21	1	B3	B^3	C6	C^3
22	1	B4	B^4	C8	C^4
23	-	TMS	-	TMS	-
24	1	B5	B^5	C10	C^5
25	1	B6	B^6	C12	C^6
26	1	B7	B^7	C14	C^7
27	1	GND (Bank 1)	-	GND (Bank 1)	-
28	1	VCCO (Bank 1)	-	VCCO (Bank 1)	-
29	1	B8	B^8	D0	D^0
30	1	B9	B^9	D2	D^1
31	1	B10	B^10	D4	D^2
32	-	TDO	-	TDO	-
33	-	VCC	-	VCC	-
34	-	GND	-	GND	-
35	1	B12	B^12	D8	D^4
36	1	B13	B^13	D10	D^5
37	1	B14	B^14	D12	D^6
38	1	B15/GOE1	B^15	D14/GOE1	D^7
39	0	CLK0/I	-	CLK0/I	-
40	0	A0/GOE0	A^0	A0/GOE0	A^0
41	0	A1	A^1	A2	A^1

**ispMACH 4032V/B/C and 4064V/B/C Logic Signal Connections:
44-Pin TQFP (Cont.)**

Pin Number	Bank Number	ispMACH 4032V/B/C		ispMACH 4064V/B/C	
		GLB/MC/Pad	ORP	GLB/MC/Pad	ORP
42	0	A2	A ²	A4	A ²
43	0	A3	A ³	A6	A ³
44	0	A4	A ⁴	A8	A ⁴

**ispMACH 4032V/B/C/Z and 4064V/B/C/Z Logic Signal Connections:
48-Pin TQFP**

Pin Number	Bank Number	ispMACH 4032V/B/C/Z		ispMACH 4064V/B/C		ispMACH 4064Z	
		GLB/MC/Pad	ORP	GLB/MC/Pad	ORP	GLB/MC/Pad	ORP
1	-	TDI	-	TDI	-	TDI	-
2	0	A5	A ⁵	A10	A ⁵	A8	A ⁵
3	0	A6	A ⁶	A12	A ⁶	A10	A ⁶
4	0	A7	A ⁷	A14	A ⁷	A11	A ⁷
5	0	GND (Bank 0)	-	GND (Bank 0)	-	GND (Bank 0)	-
6	0	VCCO (Bank 0)	-	VCCO (Bank 0)	-	VCCO (Bank 0)	-
7	0	A8	A ⁸	B0	B ⁰	B15	B ⁷
8	0	A9	A ⁹	B2	B ¹	B12	B ⁶
9	0	A10	A ¹⁰	B4	B ²	B10	B ⁵
10	0	A11	A ¹¹	B6	B ³	B8	B ⁴
11	-	TCK	-	TCK	-	TCK	-
12	-	VCC	-	VCC	-	VCC	-
13	-	GND	-	GND	-	GND	-
14	0	A12	A ¹²	B8	B ⁴	B6	B ³
15	0	A13	A ¹³	B10	B ⁵	B4	B ²
16	0	A14	A ¹⁴	B12	B ⁶	B2	B ¹
17	0	A15	A ¹⁵	B14	B ⁷	B0	B ⁰
18	0	CLK1/I	-	CLK1/I	-	CLK1/I	-
19	1	CLK2/I	-	CLK2/I	-	CLK2/I	-
20	1	B0	B ⁰	C0	C ⁰	C0	C ⁰
21	1	B1	B ¹	C2	C ¹	C1	C ¹
22	1	B2	B ²	C4	C ²	C2	C ²
23	1	B3	B ³	C6	C ³	C4	C ³
24	1	B4	B ⁴	C8	C ⁴	C6	C ⁴
25	-	TMS	-	TMS	-	TMS	-
26	1	B5	B ⁵	C10	C ⁵	C8	C ⁵
27	1	B6	B ⁶	C12	C ⁶	C10	C ⁶
28	1	B7	B ⁷	C14	C ⁷	C11	C ⁷
29	1	GND (Bank 1)	-	GND (Bank 1)	-	GND (Bank 1)	-
30	1	VCCO (Bank 1)	-	VCCO (Bank 1)	-	VCCO (Bank 1)	-
31	1	B8	B ⁸	D0	D ⁰	D15	D ⁷
32	1	B9	B ⁹	D2	D ¹	D12	D ⁶

ispMACH 4128V/B/C Logic Signal Connections: 128-Pin TQFP (Cont.)

Pin Number	Bank Number	ispMACH 4128V/B/C	
		GLB/MC/Pad	ORP
19	0	C13	C^10
20	0	C12	C^9
21	0	C10	C^8
22	0	C9	C^7
23	0	C8	C^6
24	0	GND (Bank 0)	-
25	0	C6	C^5
26	0	C5	C^4
27	0	C4	C^3
28	0	C2	C^2
29	0	C0	C^0
30	0	VCCO (Bank 0)	-
31	0	TCK	-
32	0	VCC	-
33	0	GND	-
34	0	D14	D^11
35	0	D13	D^10
36	0	D12	D^9
37	0	D10	D^8
38	0	D9	D^7
39	0	D8	D^6
40	0	GND (Bank 0)	-
41	0	VCCO (Bank 0)	-
42	0	D6	D^5
43	0	D5	D^4
44	0	D4	D^3
45	0	D2	D^2
46	0	D1	D^1
47	0	D0	D^0
48	0	CLK1/I	-
49	1	GND (Bank 1)	-
50	1	CLK2/I	-
51	1	VCC	-
52	1	E0	E^0
53	1	E1	E^1
54	1	E2	E^2
55	1	E4	E^3
56	1	E5	E^4
57	1	E6	E^5
58	1	VCCO (Bank 1)	-
59	1	GND (Bank 1)	-
60	1	E8	E^6
61	1	E9	E^7

ispMACH 4128V/B/C Logic Signal Connections: 128-Pin TQFP (Cont.)

Pin Number	Bank Number	ispMACH 4128V/B/C	
		GLB/MC/Pad	ORP
62	1	E10	E^8
63	1	E12	E^9
64	1	E14	E^11
65	1	GND	-
66	1	TMS	-
67	1	VCCO (Bank 1)	-
68	1	F0	F^0
69	1	F1	F^1
70	1	F2	F^2
71	1	F4	F^3
72	1	F5	F^4
73	1	F6	F^5
74	1	GND (Bank 1)	-
75	1	F8	F^6
76	1	F9	F^7
77	1	F10	F^8
78	1	F12	F^9
79	1	F13	F^10
80	1	F14	F^11
81	1	VCCO (Bank 1)	-
82	1	G14	G^11
83	1	G13	G^10
84	1	G12	G^9
85	1	G10	G^8
86	1	G9	G^7
87	1	G8	G^6
88	1	GND (Bank 1)	-
89	1	G6	G^5
90	1	G5	G^4
91	1	G4	G^3
92	1	G2	G^2
93	1	G0	G^0
94	1	VCCO (Bank 1)	-
95	1	TDO	-
96	1	VCC	-
97	1	GND	-
98	1	H14	H^11
99	1	H13	H^10
100	1	H12	H^9
101	1	H10	H^8
102	1	H9	H^7
103	1	H8	H^6
104	1	GND (Bank 1)	-

ispMACH 4064Z, 4128Z and 4256Z Logic Signal Connections: 132-Ball csBGA (Cont.)

Ball Number	Bank Number	ispMACH 4064Z		ispMACH 4128Z		ispMACH 4256Z	
		GLB/MC/Pad	ORP	GLB/MC/Pad	ORP	GLB/MC/Pad	ORP
D13	1	D10	D ¹⁰	G4	G ³	N6	N ³
D14	1	D9	D ⁹	G2	G ²	N8	N ⁴
D12	1	D8	D ⁸	G1	G ¹	N10	N ⁵
C14	1	I	-	G0	G ⁰	N12	N ⁶
C13	1	NC	-	VCCO (Bank 1)	-	VCCO (Bank 1)	-
B14	-	TDO	-	TDO	-	TDO	-
A14	-	VCC	-	VCC	-	VCC	-
A13	-	GND	-	GND	-	GND	-
B13	1	NC	-	H14	H ¹¹	O12	O ⁶
A12	1	I	-	H13	H ¹⁰	O10	O ⁵
C12	1	D7	D ⁷	H12	H ⁹	O8	O ⁴
B12	1	D6	D ⁶	H10	H ⁸	O6	O ³
A11	1	D5	D ⁵	H9	H ⁷	O4	O ²
C11	1	D4	D ⁴	H8	H ⁶	O2	O ¹
B11	1	GND (Bank 1)	-	GND (Bank 1)	-	GND (Bank 1)	-
A10	1	VCCO (Bank 1)	-	VCCO (Bank 1)	-	VCCO (Bank 1)	-
B10	1	NC	-	H6	H ⁵	P12	P ⁶
C10	1	NC	-	H5	H ⁴	P10	P ⁵
B9	1	D3	D ³	H4	H ³	P8	P ⁴
A9	1	D2	D ²	H2	H ²	P6	P ³
C9	1	D1	D ¹	H1	H ¹	P4	P ²
A8	1	D0/GOE1	D ⁰	H0/GOE1	H ⁰	P2/GOE1	P ¹
B8	1	CLK3/I	-	CLK3/I	-	CLK3/I	-
C8	0	CLK0/I	-	CLK0/I	-	CLK0/I	-
B7	-	VCC	-	VCC	-	VCC	-
A7	0	NC ¹	-	NC ¹	-	I ¹	-
C7	0	A0/GOE0	A ⁰	A0/GOE0	A ⁰	A2/GOE0	A ¹
A6	0	A1	A ¹	A1	A ¹	A4	A ²
B6	0	A2	A ²	A2	A ²	A6	A ³
C6	0	A3	A ³	A4	A ³	A8	A ⁴
B5	0	NC	-	A5	A ⁴	A10	A ⁵
A5	0	NC	-	A6	A ⁵	A12	A ⁶
C5	0	VCCO (Bank 0)	-	VCCO (Bank 0)	-	VCCO (Bank 0)	-
B4	0	GND (Bank 0)	-	GND (Bank 0)	-	GND (Bank 0)	-
A4	0	NC	-	A8	A ⁶	B2	B ¹
C4	0	A4	A ⁴	A9	A ⁷	B4	B ²
A3	0	A5	A ⁵	A10	A ⁸	B6	B ³
B3	0	A6	A ⁶	A12	A ⁹	B8	B ⁴
A2	0	A7	A ⁷	A13	A ¹⁰	B10	B ⁵
A1	0	NC	-	A14	A ¹¹	B12	B ⁶

1. For device migration considerations, these NC pins are input signal pins in ispMACH 4256Z device.

**ispMACH 4256V/B/C/Z, 4384V/B/C, 4512V/B/C, Logic Signal Connections:
176-Pin TQFP (Cont.)**

Pin Number	Bank Number	ispMACH 4256V/B/C/Z		ispMACH 4384V/B/C		ispMACH 4512V/B/C	
		GLB/MC/Pad	ORP	GLB/MC/Pad	ORP	GLB/MC/Pad	ORP
60	0	H8	H ⁴	L8	L ⁴	P8	P ⁴
61	0	H6	H ³	L6	L ³	P6	P ³
62	0	H4	H ²	L4	L ²	P4	P ²
63	0	H2	H ¹	L2	L ¹	P2	P ¹
64	0	H0	H ⁰	L0	L ⁰	P0	P ⁰
65	-	GND	-	GND	-	GND	-
66	0	CLK1/I	-	CLK1/I	-	CLK1/I	-
67	1	GND (Bank 1)	-	GND (Bank 1)	-	GND (Bank 1)	-
68	1	CLK2/I	-	CLK2/I	-	CLK2/I	-
69	-	VCC	-	VCC	-	VCC	-
70	1	I0	I ⁰	M0	M ⁰	AX0	AX ⁰
71	1	I2	I ¹	M2	M ¹	AX2	AX ¹
72	1	I4	I ²	M4	M ²	AX4	AX ²
73	1	I6	I ³	M6	M ³	AX6	AX ³
74	1	I8	I ⁴	M8	M ⁴	AX8	AX ⁴
75	1	I10	I ⁵	M10	M ⁵	AX10	AX ⁵
76	1	I12	I ⁶	M12	M ⁶	AX12	AX ⁶
77	1	I14	I ⁷	M14	M ⁷	AX14	AX ⁷
78	1	VCCO (Bank 1)	-	VCCO (Bank 1)	-	VCCO (Bank 1)	-
79	1	GND (Bank 1)	-	GND (Bank 1)	-	GND (Bank 1)	-
80	1	J0	J ⁰	N0	N ⁰	BX0	BX ⁰
81	1	J2	J ¹	N2	N ¹	BX2	BX ¹
82	1	J4	J ²	N4	N ²	BX4	BX ²
83	1	J6	J ³	N6	N ³	BX6	BX ³
84	1	J8	J ⁴	N8	N ⁴	BX8	BX ⁴
85	1	J10	J ⁵	N10	N ⁵	BX10	BX ⁵
86	1	J12	J ⁶	N12	N ⁶	BX12	BX ⁶
87	1	J14	J ⁷	N14	N ⁷	BX14	BX ⁷
88	-	VCC	-	VCC	-	VCC	-
89	-	NC	-	NC	-	NC	-
90	-	GND	-	GND	-	GND	-
91	-	TMS	-	TMS	-	TMS	-
92	1	VCCO (Bank 1)	-	VCCO (Bank 1)	-	VCCO (Bank 1)	-
93	1	K14	K ⁷	O14	O ⁷	CX14	CX ⁷
94	1	K12	K ⁶	O12	O ⁶	CX12	CX ⁶
95	1	K10	K ⁵	O10	O ⁵	CX10	CX ⁵
96	1	K8	K ⁴	O8	O ⁴	CX8	CX ⁴
97	1	K6	K ³	O6	O ³	CX6	CX ³
98	1	K4	K ²	O4	O ²	CX4	CX ²
99	1	K2	K ¹	O2	O ¹	CX2	CX ¹
100	1	K0	K ⁰	O0	O ⁰	CX0	CX ⁰

**ispMACH 4256V/B/C, 4384V/B/C, 4512V/B/C Logic Signal Connections:
256-Ball ftBGA/fpBGA (Cont.)**

Ball Number	I/O Bank	ispMACH 4256V/B/C 128-I/O		ispMACH 4256V/B/C 160-I/O		ispMACH 4384V/B/C		ispMACH 4512V/B/C	
		GLB/MC/Pad	ORP	GLB/MC/Pad	ORP	GLB/MC/Pad	ORP	GLB/MC/Pad	ORP
J6	0	E14	E ⁷	E10	E ⁷	H14	H ⁷	J14	J ⁷
K3	0	NC	-	E12	E ⁸	G0	G ⁰	I0	I ⁰
K4	0	NC	-	E14	E ⁹	G2	G ¹	I4	I ¹
L1	0	NC	-	NC	-	I14	I ⁷	K0	K ⁰
L2	0	NC	-	NC	-	I12	I ⁶	K2	K ¹
M1	0	NC	-	NC	-	NC	-	K4	K ²
-	0	GND (Bank 0)	-	GND (Bank 0)	-	GND (Bank 0)	-	GND (Bank 0)	-
-	0	-	-	VCCO (Bank 0)	-	VCCO (Bank 0)	-	VCCO (Bank 0)	-
M2	0	NC	-	NC	-	NC	-	K6	K ³
N1	0	NC	-	NC	-	I10	I ⁵	K8	K ⁴
M3	0	NC	-	NC	-	I8	I ⁴	K10	K ⁵
M4	0	NC	-	F0	F ⁰	G4	G ²	I8	I ²
N2	0	NC	-	F1	F ¹	G6	G ³	I12	I ³
K5	0	F0	F ⁰	F2	F ²	J0	J ⁰	N0	N ⁰
P1	0	F2	F ¹	F4	F ³	J2	J ¹	N2	N ¹
K6	0	F4	F ²	F6	F ⁴	J4	J ²	N4	N ²
N3	0	F6	F ³	F8	F ⁵	J6	J ³	N6	N ³
L5	0	F8	F ⁴	F9	F ⁶	J8	J ⁴	N8	N ⁴
P2	0	F10	F ⁵	F10	F ⁷	J10	J ⁵	N10	N ⁵
L6	0	F12	F ⁶	F12	F ⁸	J12	J ⁶	N12	N ⁶
R1	0	F14	F ⁷	F14	F ⁹	J14	J ⁷	N14	N ⁷
-	0	VCCO (Bank 0)	-	VCCO (Bank 0)	-	VCCO (Bank 0)	-	VCCO (Bank 0)	-
P3	-	TCK	-	TCK	-	TCK	-	TCK	-
-	-	VCC	-	VCC	-	VCC	-	VCC	-
-	-	GND	-	GND	-	GND	-	GND	-
-	0	-	-	GND (Bank 0)	-	GND (Bank 0)	-	GND (Bank 0)	-
T2	0	NC	-	G14	G ⁹	I6	I ³	K12	K ⁶
M5	0	NC	-	G12	G ⁸	I4	I ²	K14	K ⁷
N4	0	G14	G ⁷	G10	G ⁷	K14	K ⁷	O14	O ⁷
T3	0	G12	G ⁶	G9	G ⁶	K12	K ⁶	O12	O ⁶
R3	0	G10	G ⁵	G8	G ⁵	K10	K ⁵	O10	O ⁵
M6	0	G8	G ⁴	G6	G ⁴	K8	K ⁴	O8	O ⁴
P4	0	G6	G ³	G4	G ³	K6	K ³	O6	O ³
L7	0	G4	G ²	G2	G ²	K4	K ²	O4	O ²
N5	0	G2	G ¹	G1	G ¹	K2	K ¹	O2	O ¹
M7	0	G0	G ⁰	G0	G ⁰	K0	K ⁰	O0	O ⁰
P5	0	NC	-	NC	-	G8	G ⁴	M0	M ⁰
R4	0	NC	-	NC	-	G10	G ⁵	M4	M ¹
T4	0	NC	-	NC	-	NC	-	L0	L ⁰
-	0	GND (Bank 0)	-	GND (Bank 0)	-	GND (Bank 0)	-	GND (Bank 0)	-
-	0	VCCO (Bank 0)	-	VCCO (Bank 0)	-	VCCO (Bank 0)	-	VCCO (Bank 0)	-

**ispMACH 4256V/B/C, 4384V/B/C, 4512V/B/C Logic Signal Connections:
256-Ball ftBGA/fpBGA (Cont.)**

Ball Number	I/O Bank	ispMACH 4256V/B/C 128-I/O		ispMACH 4256V/B/C 160-I/O		ispMACH 4384V/B/C		ispMACH 4512V/B/C	
		GLB/MC/Pad	ORP	GLB/MC/Pad	ORP	GLB/MC/Pad	ORP	GLB/MC/Pad	ORP
R5	0	NC	-	NC	-	NC	-	L4	L^1
T5	0	NC	-	NC	-	I2	I^1	L8	L^2
R6	0	NC	-	NC	-	I0	I^0	L12	L^3
T6	0	NC	-	H14	H^9	G12	G^6	M8	M^2
N7	0	NC	-	H12	H^8	G14	G^7	M12	M^3
P7	0	H14	H^7	H10	H^7	L14	L^7	P14	P^7
R7	0	H12	H^6	H9	H^6	L12	L^6	P12	P^6
L8	0	H10	H^5	H8	H^5	L10	L^5	P10	P^5
T7	0	H8	H^4	H6	H^4	L8	L^4	P8	P^4
M8	0	H6	H^3	H4	H^3	L6	L^3	P6	P^3
N8	0	H4	H^2	H2	H^2	L4	L^2	P4	P^2
R8	0	H2	H^1	H1	H^1	L2	L^1	P2	P^1
P8	0	H0	H^0	H0	H^0	L0	L^0	P0	P^0
-	-	GND	-	GND	-	GND	-	GND	-
T8	0	CLK1/I	-	CLK1/I	-	CLK1/I	-	CLK1/I	-
-	1	GND (Bank 1)	-	GND (Bank 1)	-	GND (Bank 1)	-	GND (Bank 1)	-
N9	1	CLK2/I	-	CLK2/I	-	CLK2/I	-	CLK2/I	-
-	-	VCC	-	VCC	-	VCC	-	VCC	-
P9	1	I0	I^0	I0	I^0	M0	M^0	AX0	AX^0
R9	1	I2	I^1	I1	I^1	M2	M^1	AX2	AX^1
T9	1	I4	I^2	I2	I^2	M4	M^2	AX4	AX^2
T10	1	I6	I^3	I4	I^3	M6	M^3	AX6	AX^3
R10	1	I8	I^4	I6	I^4	M8	M^4	AX8	AX^4
M9	1	I10	I^5	I8	I^5	M10	M^5	AX10	AX^5
P10	1	I12	I^6	I9	I^6	M12	M^6	AX12	AX^6
L9	1	I14	I^7	I10	I^7	M14	M^7	AX14	AX^7
N10	1	NC	-	I12	I^8	BX14	BX^7	DX0	DX^0
T11	1	NC	-	I14	I^9	BX12	BX^6	DX4	DX^1
R11	1	NC	-	NC	-	P0	P^0	EX0	EX^0
T12	1	NC	-	NC	-	P2	P^1	EX4	EX^1
N12	1	NC	-	NC	-	NC	-	EX8	EX^2
-	1	VCCO (Bank 1)	-	VCCO (Bank 1)	-	VCCO (Bank 1)	-	VCCO (Bank 1)	-
-	1	GND (Bank 1)	-	GND (Bank 1)	-	GND (Bank 1)	-	GND (Bank 1)	-
R12	1	NC	-	NC	-	NC	-	EX12	EX^3
T13	1	NC	-	J0	J^0	BX10	BX^5	DX8	DX^2
P12	1	NC	-	J1	J^1	BX8	BX^4	DX12	DX^3
M10	1	J0	J^0	J2	J^2	N0	N^0	BX0	BX^0
R13	1	J2	J^1	J4	J^3	N2	N^1	BX2	BX^1
L10	1	J4	J^2	J6	J^4	N4	N^2	BX4	BX^2
T14	1	J6	J^3	J8	J^5	N6	N^3	BX6	BX^3
M11	1	J8	J^4	J9	J^6	N8	N^4	BX8	BX^4

ispMACH 4000V (3.3V) Industrial Devices (Cont.)

Family	Part Number	Macrocells	Voltage	t _{PD}	Package	Pin/Ball Count	I/O	Grade
LC4256V	LC4256V-5FT256AI	256	3.3	5	ftBGA	256	128	I
	LC4256V-75FT256AI	256	3.3	7.5	ftBGA	256	128	I
	LC4256V-10FT256AI	256	3.3	10	ftBGA	256	128	I
	LC4256V-5FT256BI	256	3.3	5	ftBGA	256	160	I
	LC4256V-75FT256BI	256	3.3	7.5	ftBGA	256	160	I
	LC4256V-10FT256BI	256	3.3	10	ftBGA	256	160	I
	LC4256V-5F256AI ¹	256	3.3	5	fpBGA	256	128	I
	LC4256V-75F256AI ¹	256	3.3	7.5	fpBGA	256	128	I
	LC4256V-10F256AI ¹	256	3.3	10	fpBGA	256	128	I
	LC4256V-5F256BI ¹	256	3.3	5	fpBGA	256	160	I
	LC4256V-75F256BI ¹	256	3.3	7.5	fpBGA	256	160	I
	LC4256V-10F256BI ¹	256	3.3	10	fpBGA	256	160	I
	LC4256V-5T176I	256	3.3	5	TQFP	176	128	I
	LC4256V-75T176I	256	3.3	7.5	TQFP	176	128	I
	LC4256V-10T176I	256	3.3	10	TQFP	176	128	I
	LC4256V-5T144I	256	3.3	5	TQFP	144	96	I
	LC4256V-75T144I	256	3.3	7.5	TQFP	144	96	I
	LC4256V-10T144I	256	3.3	10	TQFP	144	96	I
	LC4256V-5T100I	256	3.3	5	TQFP	100	64	I
	LC4256V-75T100I	256	3.3	7.5	TQFP	100	64	I
LC4256V-10T100I	256	3.3	10	TQFP	100	64	I	
LC4384V	LC4384V-5FT256I	384	3.3	5	ftBGA	256	192	I
	LC4384V-75FT256I	384	3.3	7.5	ftBGA	256	192	I
	LC4384V-10FT256I	384	3.3	10	ftBGA	256	192	I
	LC4384V-5F256I ¹	384	3.3	5	fpBGA	256	192	I
	LC4384V-75F256I ¹	384	3.3	7.5	fpBGA	256	192	I
	LC4384V-10F256I ¹	384	3.3	10	fpBGA	256	192	I
	LC4384V-5T176I	384	3.3	5	TQFP	176	128	I
	LC4384V-75T176I	384	3.3	7.5	TQFP	176	128	I
	LC4384V-10T176I	384	3.3	10	TQFP	176	128	I
LC4512V	LC4512V-5FT256I	512	3.3	5	ftBGA	256	208	I
	LC4512V-75FT256I	512	3.3	7.5	ftBGA	256	208	I
	LC4512V-10FT256I	512	3.3	10	ftBGA	256	208	I
	LC4512V-5F256I ¹	512	3.3	5	fpBGA	256	208	I
	LC4512V-75F256I ¹	512	3.3	7.5	fpBGA	256	208	I
	LC4512V-10F256I ¹	512	3.3	10	fpBGA	256	208	I
	LC4512V-5T176I	512	3.3	5	TQFP	176	128	I
	LC4512V-75T176I	512	3.3	7.5	TQFP	176	128	I
	LC4512V-10T176I	512	3.3	10	TQFP	176	128	I

1. Use ftBGA package. fpBGA package devices have been discontinued via PCN#14A-07.

Lead-Free Packaging**ispMACH 4000Z (Zero Power, 1.8V) Lead-Free Commercial Devices**

Device	Part Number	Macrocells	Voltage	t _{PD}	Package	Pin/Ball Count	I/O	Grade
LC4032ZC	LC4032ZC-35MN56C	32	1.8	3.5	Lead-free csBGA	56	32	C
	LC4032ZC-5MN56C	32	1.8	5	Lead-free csBGA	56	32	C
	LC4032ZC-75MN56C	32	1.8	7.5	Lead-free csBGA	56	32	C
	LC4032ZC-35TN48C	32	1.8	3.5	Lead-free TQFP	48	32	C
	LC4032ZC-5TN48C	32	1.8	5	Lead-free TQFP	48	32	C
	LC4032ZC-75TN48C	32	1.8	7.5	Lead-free TQFP	48	32	C
LC4064ZC	LC4064ZC-37MN132C	64	1.8	3.7	Lead-free csBGA	132	64	C
	LC4064ZC-5MN132C	64	1.8	5	Lead-free csBGA	132	64	C
	LC4064ZC-75MN132C	64	1.8	7.5	Lead-free csBGA	132	64	C
	LC4064ZC-37TN100C	64	1.8	3.7	Lead-free TQFP	100	64	C
	LC4064ZC-5TN100C	64	1.8	5	Lead-free TQFP	100	64	C
	LC4064ZC-75TN100C	64	1.8	7.5	Lead-free TQFP	100	64	C
	LC4064ZC-37MN56C	64	1.8	3.7	Lead-free csBGA	56	32	C
	LC4064ZC-5MN56C	64	1.8	5	Lead-free csBGA	56	32	C
	LC4064ZC-75MN56C	64	1.8	7.5	Lead-free csBGA	56	32	C
	LC4064ZC-37TN48C	64	1.8	3.7	Lead-free TQFP	48	32	C
	LC4064ZC-5TN48C	64	1.8	5	Lead-free TQFP	48	32	C
	LC4064ZC-75TN48C	64	1.8	7.5	Lead-free TQFP	48	32	C
LC4128ZC	LC4128ZC-42MN132C	128	1.8	4.2	Lead-free csBGA	132	96	C
	LC4128ZC-75MN132C	128	1.8	7.5	Lead-free csBGA	132	96	C
	LC4128ZC-42TN100C	128	1.8	4.2	Lead-free TQFP	100	64	C
	LC4128ZC-75TN100C	128	1.8	7.5	Lead-free TQFP	100	64	C
LC4256ZC	LC4256ZC-45TN176C	256	1.8	4.5	Lead-free TQFP	176	128	C
	LC4256ZC-75TN176C	256	1.8	7.5	Lead-free TQFP	176	128	C
	LC4256ZC-45MN132C	256	1.8	4.5	Lead-free csBGA	132	96	C
	LC4256ZC-75MN132C	256	1.8	7.5	Lead-free csBGA	132	96	C
	LC4256ZC-45TN100C	256	1.8	4.5	Lead-free TQFP	100	64	C
	LC4256ZC-75TN100C	256	1.8	7.5	Lead-free TQFP	100	64	C

ispMACH 4000Z (Zero Power, 1.8V) Lead-Free Industrial Devices

Device	Part Number	Macrocells	Voltage	t _{PD}	Package	Pin/Ball Count	I/O	Grade
LC4032ZC	LC4032ZC-5MN56I	32	1.8	5	Lead-free csBGA	56	32	I
	LC4032ZC-75MN56I	32	1.8	7.5	Lead-free csBGA	56	32	I
	LC4032ZC-5TN48I	32	1.8	5	Lead-free TQFP	48	32	I
	LC4032ZC-75TN48I	32	1.8	7.5	Lead-free TQFP	48	32	I

ispMACH 4000B (2.5V) Lead-Free Commercial Devices

Device	Part Number	Macrocells	Voltage	t _{PD}	Package	Pin/Ball Count	I/O	Grade
LC4032B	LC4032B-25TN48C	32	2.5	2.5	Lead-Free TQFP	48	32	C
	LC4032B-5TN48C	32	2.5	5	Lead-Free TQFP	48	32	C
	LC4032B-75TN48C	32	2.5	7.5	Lead-Free TQFP	48	32	C
	LC4032B-25TN44C	32	2.5	2.5	Lead-Free TQFP	44	30	C
	LC4032B-5TN44C	32	2.5	5	Lead-Free TQFP	44	30	C
	LC4032B-75TN44C	32	2.5	7.5	Lead-Free TQFP	44	30	C
LC4064B	LC4064B-25TN100C	64	2.5	2.5	Lead-Free TQFP	100	64	C
	LC4064B-5TN100C	64	2.5	5	Lead-Free TQFP	100	64	C
	LC4064B-75TN100C	64	2.5	7.5	Lead-Free TQFP	100	64	C
	LC4064B-25TN48C	64	2.5	2.5	Lead-Free TQFP	48	32	C
	LC4064B-5TN48C	64	2.5	5	Lead-Free TQFP	48	32	C
	LC4064B-75TN48C	64	2.5	7.5	Lead-Free TQFP	48	32	C
	LC4064B-25TN44C	64	2.5	2.5	Lead-Free TQFP	44	30	C
	LC4064B-5TN44C	64	2.5	5	Lead-Free TQFP	44	30	C
LC4128B	LC4128B-27TN128C	128	2.5	2.7	Lead-Free TQFP	128	92	C
	LC4128B-5TN128C	128	2.5	5	Lead-Free TQFP	128	92	C
	LC4128B-75TN128C	128	2.5	7.5	Lead-Free TQFP	128	92	C
	LC4128B-27TN100C	128	2.5	2.7	Lead-Free TQFP	100	92	C
	LC4128B-5TN100C	128	2.5	5	Lead-Free TQFP	100	92	C
	LC4128B-75TN100C	128	2.5	7.5	Lead-Free TQFP	100	92	C
LC4256B	LC4256B-3FTN256AC	256	2.5	3	Lead-Free ftBGA	256	128	C
	LC4256B-5FTN256AC	256	2.5	5	Lead-Free ftBGA	256	128	C
	LC4256B-75FTN256AC	256	2.5	7.5	Lead-Free ftBGA	256	128	C
	LC4256B-3FTN256BC	256	2.5	3	Lead-Free ftBGA	256	160	C
	LC4256B-5FTN256BC	256	2.5	5	Lead-Free ftBGA	256	160	C
	LC4256B-75FTN256BC	256	2.5	7.5	Lead-Free ftBGA	256	160	C
	LC4256B-3FN256AC ¹	256	2.5	3	Lead-Free fpBGA	256	128	C
	LC4256B-5FN256AC ¹	256	2.5	5	Lead-Free fpBGA	256	128	C
	LC4256B-75FN256AC ¹	256	2.5	7.5	Lead-Free fpBGA	256	128	C
	LC4256B-3FN256BC ¹	256	2.5	3	Lead-Free fpBGA	256	160	C
	LC4256B-5FN256BC ¹	256	2.5	5	Lead-Free fpBGA	256	160	C
	LC4256B-75FN256BC ¹	256	2.5	7.5	Lead-Free fpBGA	256	160	C
	LC4256B-3TN176C	256	2.5	3	Lead-Free TQFP	176	128	C
	LC4256B-5TN176C	256	2.5	5	Lead-Free TQFP	176	128	C
	LC4256B-75TN176C	256	2.5	7.5	Lead-Free TQFP	176	128	C
	LC4256B-3TN100C	256	2.5	3	Lead-Free TQFP	100	64	C
LC4256B-5TN100C	256	2.5	5	Lead-Free TQFP	100	64	C	
LC4256B-75TN100C	256	2.5	7.5	Lead-Free TQFP	100	64	C	

ispMACH 4000B (2.5V) Lead-Free Industrial Devices (Cont.)

Device	Part Number	Macrocells	Voltage	t _{PD}	Package	Pin/Ball Count	I/O	Grade
LC4128B	LC4128B-5TN128I	128	2.5	5	Lead-Free TQFP	128	92	I
	LC4128B-75TN128I	128	2.5	7.5	Lead-Free TQFP	128	92	I
	LC4128B-10TN128I	128	2.5	10	Lead-Free TQFP	128	92	I
	LC4128B-5TN100I	128	2.5	5	Lead-Free TQFP	100	64	I
	LC4128B-75TN100I	128	2.5	7.5	Lead-Free TQFP	100	64	I
	LC4128B-10TN100I	128	2.5	10	Lead-Free TQFP	100	64	I
LC4256B	LC4256B-5FTN256AI	256	2.5	5	Lead-Free ftBGA	256	128	I
	LC4256B-75FTN256AI	256	2.5	7.5	Lead-Free ftBGA	256	128	I
	LC4256B-10FTN256AI	256	2.5	10	Lead-Free ftBGA	256	128	I
	LC4256B-5FTN256BI	256	2.5	5	Lead-Free ftBGA	256	160	I
	LC4256B-75FTN256BI	256	2.5	7.5	Lead-Free ftBGA	256	160	I
	LC4256B-10FTN256BI	256	2.5	10	Lead-Free ftBGA	256	160	I
	LC4256B-5FN256AI ¹	256	2.5	5	Lead-Free fpBGA	256	128	I
	LC4256B-75FN256AI ¹	256	2.5	7.5	Lead-Free fpBGA	256	128	I
	LC4256B-10FN256AI ¹	256	2.5	10	Lead-Free fpBGA	256	128	I
	LC4256B-5FN256BI ¹	256	2.5	5	Lead-Free fpBGA	256	160	I
	LC4256B-75FN256BI ¹	256	2.5	7.5	Lead-Free fpBGA	256	160	I
	LC4256B-10FN256BI ¹	256	2.5	10	Lead-Free fpBGA	256	160	I
	LC4256B-5TN176I	256	2.5	5	Lead-Free TQFP	176	128	I
	LC4256B-75TN176I	256	2.5	7.5	Lead-Free TQFP	176	128	I
	LC4256B-10TN176I	256	2.5	10	Lead-Free TQFP	176	128	I
	LC4256B-5TN100I	256	2.5	5	Lead-Free TQFP	100	64	I
LC4256B-75TN100I	256	2.5	7.5	Lead-Free TQFP	100	64	I	
LC4256B-10TN100I	256	2.5	10	Lead-Free TQFP	100	64	I	
LC4384B	LC4384B-5FTN256I	384	2.5	5	Lead-Free ftBGA	256	192	I
	LC4384B-75FTN256I	384	2.5	7.5	Lead-Free ftBGA	256	192	I
	LC4384B-10FTN256I	384	2.5	10	Lead-Free ftBGA	256	192	I
	LC4384B-5FN256I ¹	384	2.5	5	Lead-Free fpBGA	256	192	I
	LC4384B-75FN256I ¹	384	2.5	7.5	Lead-Free fpBGA	256	192	I
	LC4384B-10FN256I ¹	384	2.5	10	Lead-Free fpBGA	256	192	I
	LC4384B-5TN176I	384	2.5	5	Lead-Free TQFP	176	128	I
	LC4384B-75TN176I	384	2.5	7.5	Lead-Free TQFP	176	128	I
	LC4384B-10TN176I	384	2.5	10	Lead-Free TQFP	176	128	I
LC4512B	LC4512B-5FTN256I	512	2.5	5	Lead-Free ftBGA	256	208	I
	LC4512B-75FTN256I	512	2.5	7.5	Lead-Free ftBGA	256	208	I
	LC4512B-10FTN256I	512	2.5	10	Lead-Free ftBGA	256	208	I
	LC4512B-5FN256I ¹	512	2.5	5	Lead-Free fpBGA	256	208	I
	LC4512B-75FN256I ¹	512	2.5	7.5	Lead-Free fpBGA	256	208	I
	LC4512B-10FN256I ¹	512	2.5	10	Lead-Free fpBGA	256	208	I
	LC4512B-5TN176I	512	2.5	5	Lead-Free TQFP	176	128	I
	LC4512B-75TN176I	512	2.5	7.5	Lead-Free TQFP	176	128	I
LC4512B-10TN176I	512	2.5	10	Lead-Free TQFP	176	128	I	

1. Use ftBGA package. fpBGA package devices have been discontinued via PCN#14A-07.

ispMACH 4000V (3.3V) Lead-Free Industrial Devices (Cont.)

Device	Part Number	Macrocells	Voltage	t _{PD}	Package	Pin/Ball Count	I/O	Grade
LC4256V	LC4256V-5FTN256AI	256	3.3	5	Lead-free ftBGA	256	128	I
	LC4256V-75FTN256AI	256	3.3	7.5	Lead-free ftBGA	256	128	I
	LC4256V-10FTN256AI	256	3.3	10	Lead-free ftBGA	256	128	I
	LC4256V-5FTN256BI	256	3.3	5	Lead-free ftBGA	256	160	I
	LC4256V-75FTN256BI	256	3.3	7.5	Lead-free ftBGA	256	160	I
	LC4256V-10FTN256BI	256	3.3	10	Lead-free ftBGA	256	160	I
	LC4256V-5FN256AI ¹	256	3.3	5	Lead-free fpBGA	256	128	I
	LC4256V-75FN256AI ¹	256	3.3	7.5	Lead-free fpBGA	256	128	I
	LC4256V-10FN256AI ¹	256	3.3	10	Lead-free fpBGA	256	128	I
	LC4256V-5FN256BI ¹	256	3.3	5	Lead-free fpBGA	256	160	I
	LC4256V-75FN256BI ¹	256	3.3	7.5	Lead-free fpBGA	256	160	I
	LC4256V-10FN256BI ¹	256	3.3	10	Lead-free fpBGA	256	160	I
	LC4256V-5TN176I	256	3.3	5	Lead-free TQFP	176	128	I
	LC4256V-75TN176I	256	3.3	7.5	Lead-free TQFP	176	128	I
	LC4256V-10TN176I	256	3.3	10	Lead-free TQFP	176	128	I
	LC4256V-5TN144I	256	3.3	5	Lead-free TQFP	144	96	I
	LC4256V-75TN144I	256	3.3	7.5	Lead-free TQFP	144	96	I
	LC4256V-10TN144I	256	3.3	10	Lead-free TQFP	144	96	I
	LC4256V-5TN100I	256	3.3	5	Lead-free TQFP	100	64	I
	LC4256V-75TN100I	256	3.3	7.5	Lead-free TQFP	100	64	I
LC4256V-10TN100I	256	3.3	10	Lead-free TQFP	100	64	I	
LC4384V	LC4384V-5FTN256I	384	3.3	5	Lead-free ftBGA	256	192	I
	LC4384V-75FTN256I	384	3.3	7.5	Lead-free ftBGA	256	192	I
	LC4384V-10FTN256I	384	3.3	10	Lead-free ftBGA	256	192	I
	LC4384V-5FN256I ¹	384	3.3	5	Lead-free fpBGA	256	192	I
	LC4384V-75FN256I ¹	384	3.3	7.5	Lead-free fpBGA	256	192	I
	LC4384V-10FN256I ¹	384	3.3	10	Lead-free fpBGA	256	192	I
	LC4384V-5TN176I	384	3.3	5	Lead-free TQFP	176	128	I
	LC4384V-75TN176I	384	3.3	7.5	Lead-free TQFP	176	128	I
LC4384V-10TN176I	384	3.3	10	Lead-free TQFP	176	128	I	
LC4512V	LC4512V-5FTN256I	512	3.3	5	Lead-free ftBGA	256	208	I
	LC4512V-75FTN256I	512	3.3	7.5	Lead-free ftBGA	256	208	I
	LC4512V-10FTN256I	512	3.3	10	Lead-free ftBGA	256	208	I
	LC4512V-5FN256I ¹	512	3.3	5	Lead-free fpBGA	256	208	I
	LC4512V-75FN256I ¹	512	3.3	7.5	Lead-free fpBGA	256	208	I
	LC4512V-10FN256I ¹	512	3.3	10	Lead-free fpBGA	256	208	I
	LC4512V-5TN176I	512	3.3	5	Lead-free TQFP	176	128	I
	LC4512V-75TN176I	512	3.3	7.5	Lead-free TQFP	176	128	I
	LC4512V-10TN176I	512	3.3	10	Lead-free TQFP	176	128	I

1. Use ftBGA package. fpBGA package devices have been discontinued via PCN#14A-07.