

Welcome to [E-XFL.COM](https://www.e-xfl.com)

Understanding [Embedded - CPLDs \(Complex Programmable Logic Devices\)](#)

Embedded - CPLDs, or Complex Programmable Logic Devices, are highly versatile digital logic devices used in electronic systems. These programmable components are designed to perform complex logical operations and can be customized for specific applications. Unlike fixed-function ICs, CPLDs offer the flexibility to reprogram their configuration, making them an ideal choice for various embedded systems. They consist of a set of logic gates and programmable interconnects, allowing designers to implement complex logic circuits without needing custom hardware.

Applications of Embedded - CPLDs

Details

Product Status	Active
Programmable Type	In System Programmable
Delay Time tpd(1) Max	7.5 ns
Voltage Supply - Internal	3V ~ 3.6V
Number of Logic Elements/Blocks	4
Number of Macrocells	64
Number of Gates	-
Number of I/O	30
Operating Temperature	0°C ~ 90°C (TJ)
Mounting Type	Surface Mount
Package / Case	44-TQFP
Supplier Device Package	44-TQFP (10x10)
Purchase URL	https://www.e-xfl.com/product-detail/lattice-semiconductor/lc4064v-75tn44c

Output Routing Pool (ORP)

The Output Routing Pool allows macrocell outputs to be connected to any of several I/O cells within an I/O block. This provides greater flexibility in determining the pinout and allows design changes to occur without affecting the pinout. The output routing pool also provides a parallel capability for routing macrocell-level OE product terms. This allows the OE product term to follow the macrocell output as it is switched between I/O cells. Additionally, the output routing pool allows the macrocell output or true and complement forms of the 5-PT bypass signal to bypass the output routing multiplexers and feed the I/O cell directly. The enhanced ORP of the ispMACH 4000 family consists of the following elements:

- Output Routing Multiplexers
- OE Routing Multiplexers
- Output Routing Pool Bypass Multiplexers

Figure 7 shows the structure of the ORP from the I/O cell perspective. This is referred to as an ORP slice. Each ORP has as many ORP slices as there are I/O cells in the corresponding I/O block.

Figure 7. ORP Slice

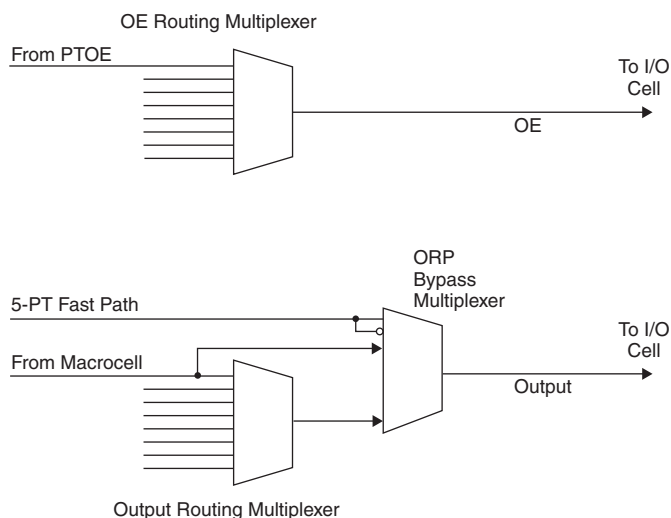

Output Routing Multiplexers

The details of connections between the macrocells and the I/O cells vary across devices and within a device dependent on the maximum number of I/Os available. Tables 5-9 provide the connection details.

Table 6. ORP Combinations for I/O Blocks with 8 I/Os

I/O Cell	Available Macrocells
I/O 0	M0, M1, M2, M3, M4, M5, M6, M7
I/O 1	M2, M3, M4, M5, M6, M7, M8, M9
I/O 2	M4, M5, M6, M7, M8, M9, M10, M11
I/O 3	M6, M7, M8, M9, M10, M11, M12, M13
I/O 4	M8, M9, M10, M11, M12, M13, M14, M15
I/O 5	M10, M11, M12, M13, M14, M15, M0, M1
I/O 6	M12, M13, M14, M15, M0, M1, M2, M3
I/O 7	M14, M15, M0, M1, M2, M3, M4, M5

Table 7. ORP Combinations for I/O Blocks with 16 I/Os

I/O Cell	Available Macrocells
I/O 0	M0, M1, M2, M3, M4, M5, M6, M7
I/O 1	M1, M2, M3, M4, M5, M6, M7, M8
I/O 2	M2, M3, M4, M5, M6, M7, M8, M9
I/O 3	M3, M4, M5, M6, M7, M8, M9, M10
I/O 4	M4, M5, M6, M7, M8, M9, M10, M11
I/O 5	M5, M6, M7, M8, M9, M10, M11, M12
I/O 6	M6, M7, M8, M9, M10, M11, M12, M13
I/O 7	M7, M8, M9, M10, M11, M12, M13, M14
I/O 8	M8, M9, M10, M11, M12, M13, M14, M15
I/O 9	M9, M10, M11, M12, M13, M14, M15, M0
I/O 10	M10, M11, M12, M13, M14, M15, M0, M1
I/O 11	M11, M12, M13, M14, M15, M0, M1, M2
I/O 12	M12, M13, M14, M15, M0, M1, M2, M3
I/O 13	M13, M14, M15, M0, M1, M2, M3, M4
I/O 14	M14, M15, M0, M1, M2, M3, M4, M5
I/O 15	M15, M0, M1, M2, M3, M4, M5, M6

Table 8. ORP Combinations for I/O Blocks with 4 I/Os

I/O Cell	Available Macrocells
I/O 0	M0, M1, M2, M3, M4, M5, M6, M7
I/O 1	M4, M5, M6, M7, M8, M9, M10, M11
I/O 2	M8, M9, M10, M11, M12, M13, M14, M15
I/O 3	M12, M13, M14, M15, M0, M1, M2, M3

Table 9. ORP Combinations for I/O Blocks with 10 I/Os

I/O Cell	Available Macrocells
I/O 0	M0, M1, M2, M3, M4, M5, M6, M7
I/O 1	M2, M3, M4, M5, M6, M7, M8, M9
I/O 2	M4, M5, M6, M7, M8, M9, M10, M11
I/O 3	M6, M7, M8, M9, M10, M11, M12, M13
I/O 4	M8, M9, M10, M11, M12, M13, M14, M15
I/O 5	M10, M11, M12, M13, M14, M15, M0, M1
I/O 6	M12, M13, M14, M15, M0, M1, M2, M3
I/O 7	M14, M15, M0, M1, M2, M3, M4, M5
I/O 8	M2, M3, M4, M5, M6, M7, M8, M9
I/O 9	M10, M11, M12, M13, M14, M15, M0, M1

Absolute Maximum Ratings^{1, 2, 3}

	ispMACH 4000C/Z (1.8V)	ispMACH 4000B (2.5V)	ispMACH 4000V (3.3V)
Supply Voltage (V_{CC})	-0.5 to 2.5V	-0.5 to 5.5V	-0.5 to 5.5V
Output Supply Voltage (V_{CCO})	-0.5 to 4.5V	-0.5 to 4.5V	-0.5 to 4.5V
Input or I/O Tristate Voltage Applied ^{4, 5}	-0.5 to 5.5V	-0.5 to 5.5V	-0.5 to 5.5V
Storage Temperature	-65 to 150°C	-65 to 150°C	-65 to 150°C
Junction Temperature (T_j) with Power Applied	-55 to 150°C	-55 to 150°C	-55 to 150°C

1. Stress above those listed under the “Absolute Maximum Ratings” may cause permanent damage to the device. Functional operation of the device at these or any other conditions above those indicated in the operational sections of this specification is not implied.
2. Compliance with Lattice [Thermal Management](#) document is required.
3. All voltages referenced to GND.
4. Undershoot of -2V and overshoot of (V_{IH} (MAX) + 2V), up to a total pin voltage of 6.0V, is permitted for a duration of < 20ns.
5. Maximum of 64 I/Os per device with $V_{IN} > 3.6V$ is allowed.

Recommended Operating Conditions

Symbol	Parameter	Min.	Max.	Units	
V_{CC}	Supply Voltage for 1.8V Devices	ispMACH 4000C	1.65	1.95	V
		ispMACH 4000Z	1.7	1.9	V
		ispMACH 4000Z, Extended Functional Voltage Operation	1.6 ^{1, 2}	1.9	V
	Supply Voltage for 2.5V Devices	2.3	2.7	V	
	Supply Voltage for 3.3V Devices	3.0	3.6	V	
T_j	Junction Temperature (Commercial)	0	90	C	
	Junction Temperature (Industrial)	-40	105	C	
	Junction Temperature (Extended)	-40	130	C	

1. Devices operating at 1.6V can expect performance degradation up to 35%.
2. Applicable for devices with 2004 date codes and later. Contact factory for ordering instructions.

Erase Reprogram Specifications

Parameter	Min.	Max.	Units
Erase/Reprogram Cycle	1,000	—	Cycles

Note: Valid over commercial temperature range.

Hot Socketing Characteristics^{1,2,3}

Symbol	Parameter	Condition	Min.	Typ.	Max.	Units
I_{DK}	Input or I/O Leakage Current	$0 \leq V_{IN} \leq 3.0V, T_j = 105^\circ C$	—	±30	±150	µA
		$0 \leq V_{IN} \leq 3.0V, T_j = 130^\circ C$	—	±30	±200	µA

1. Insensitive to sequence of V_{CC} or V_{CCO} . However, assumes monotonic rise/fall rates for V_{CC} and V_{CCO} , provided $(V_{IN} - V_{CCO}) \leq 3.6V$.
2. $0 < V_{CC} < V_{CC} (MAX), 0 < V_{CCO} < V_{CCO} (MAX)$.
3. I_{DK} is additive to I_{PU}, I_{PD} or I_{BH} . Device defaults to pull-up until fuse circuitry is active.

I/O DC Electrical Characteristics

Over Recommended Operating Conditions

Standard	V_{IL}		V_{IH}		V_{OL} Max (V)	V_{OH} Min (V)	I_{OL}^1 (mA)	I_{OH}^1 (mA)
	Min (V)	Max (V)	Min (V)	Max (V)				
LVTTTL	-0.3	0.80	2.0	5.5	0.40	$V_{CCO} - 0.40$	8.0	-4.0
					0.20	$V_{CCO} - 0.20$	0.1	-0.1
LVCMOS 3.3	-0.3	0.80	2.0	5.5	0.40	$V_{CCO} - 0.40$	8.0	-4.0
					0.20	$V_{CCO} - 0.20$	0.1	-0.1
LVCMOS 2.5	-0.3	0.70	1.70	3.6	0.40	$V_{CCO} - 0.40$	8.0	-4.0
					0.20	$V_{CCO} - 0.20$	0.1	-0.1
LVCMOS 1.8 (4000V/B)	-0.3	0.63	1.17	3.6	0.40	$V_{CCO} - 0.45$	2.0	-2.0
					0.20	$V_{CCO} - 0.20$	0.1	-0.1
LVCMOS 1.8 (4000C/Z)	-0.3	$0.35 * V_{CC}$	$0.65 * V_{CC}$	3.6	0.40	$V_{CCO} - 0.45$	2.0	-2.0
					0.20	$V_{CCO} - 0.20$	0.1	-0.1
PCI 3.3 (4000V/B)	-0.3	1.08	1.5	5.5	$0.1 V_{CCO}$	$0.9 V_{CCO}$	1.5	-0.5
PCI 3.3 (4000C/Z)	-0.3	$0.3 * 3.3 * (V_{CC} / 1.8)$	$0.5 * 3.3 * (V_{CC} / 1.8)$	5.5	$0.1 V_{CCO}$	$0.9 V_{CCO}$	1.5	-0.5

1. The average DC current drawn by I/Os between adjacent bank GND connections, or between the last GND in an I/O bank and the end of the I/O bank, as shown in the logic signals connection table, shall not exceed $n * 8\text{mA}$. Where n is the number of I/Os between bank GND connections or between the last GND in a bank and the end of a bank.

ispMACH 4000V/B/C External Switching Characteristics

Over Recommended Operating Conditions

Parameter	Description ^{1, 2, 3}	-25		-27		-3		-35		Units
		Min.	Max.	Min.	Max.	Min.	Max.	Min.	Max.	
t _{PD}	5-PT bypass combinatorial propagation delay	—	2.5	—	2.7	—	3.0	—	3.5	ns
t _{PD_MC}	20-PT combinatorial propagation delay through macrocell	—	3.2	—	3.5	—	3.8	—	4.2	ns
t _S	GLB register setup time before clock	1.8	—	1.8	—	2.0	—	2.0	—	ns
t _{ST}	GLB register setup time before clock with T-type register	2.0	—	2.0	—	2.2	—	2.2	—	ns
t _{SIR}	GLB register setup time before clock, input register path	0.7	—	1.0	—	1.0	—	1.0	—	ns
t _{SIRZ}	GLB register setup time before clock with zero hold	1.7	—	2.0	—	2.0	—	2.0	—	ns
t _H	GLB register hold time after clock	0.0	—	0.0	—	0.0	—	0.0	—	ns
t _{HT}	GLB register hold time after clock with T-type register	0.0	—	0.0	—	0.0	—	0.0	—	ns
t _{HIR}	GLB register hold time after clock, input register path	0.9	—	1.0	—	1.0	—	1.0	—	ns
t _{HIRZ}	GLB register hold time after clock, input register path with zero hold	0.0	—	0.0	—	0.0	—	0.0	—	ns
t _{CO}	GLB register clock-to-output delay	—	2.2	—	2.7	—	2.7	—	2.7	ns
t _R	External reset pin to output delay	—	3.5	—	4.0	—	4.4	—	4.5	ns
t _{RW}	External reset pulse duration	1.5	—	1.5	—	1.5	—	1.5	-	ns
t _{P_{TOE/DIS}}	Input to output local product term output enable/disable	—	4.0	—	4.5	—	5.0	—	5.5	ns
t _{G_{P_{TOE/DIS}}}	Input to output global product term output enable/disable	—	5.0	—	6.5	—	8.0	—	8.0	ns
t _{G_{OE/DIS}}	Global OE input to output enable/disable	—	3.0	—	3.5	—	4.0	—	4.5	ns
t _{CW}	Global clock width, high or low	1.1	—	1.3	—	1.3	—	1.3	—	ns
t _{GW}	Global gate width low (for low transparent) or high (for high transparent)	1.1	—	1.3	—	1.3	—	1.3	—	ns
t _{WIR}	Input register clock width, high or low	1.1	—	1.3	—	1.3	—	1.3	—	ns
f _{MAX} ⁴	Clock frequency with internal feedback	—	400	—	333	—	322	—	322	MHz
f _{MAX} (Ext.)	Clock frequency with external feedback, [1/ (t _S + t _{CO})]	—	250	—	222	—	212	—	212	MHz

1. Timing numbers are based on default LVCMOS 1.8 I/O buffers. Use timing adjusters provided to calculate other standards.

Timing v.3.2

2. Measured using standard switching circuit, assuming GRP loading of 1 and 1 output switching.

3. Pulse widths and clock widths less than minimum will cause unknown behavior.

4. Standard 16-bit counter using GRP feedback.

ispMACH 4000Z External Switching Characteristics

Over Recommended Operating Conditions

Parameter	Description ^{1, 2, 3}	-35		-37		-42		Units
		Min.	Max.	Min.	Max.	Min.	Max.	
t _{PD}	5-PT bypass combinatorial propagation delay	—	3.5	—	3.7	—	4.2	ns
t _{PD_MC}	20-PT combinatorial propagation delay through macrocell	—	4.4	—	4.7	—	5.7	ns
t _S	GLB register setup time before clock	2.2	—	2.5	—	2.7	—	ns
t _{ST}	GLB register setup time before clock with T-type register	2.4	—	2.7	—	2.9	—	ns
t _{SIR}	GLB register setup time before clock, input register path	1.0	—	1.1	—	1.3	—	ns
t _{SIRZ}	GLB register setup time before clock with zero hold	2.0	—	2.1	—	2.6	—	ns
t _H	GLB register hold time after clock	0.0	—	0.0	—	0.0	—	ns
t _{HT}	GLB register hold time after clock with T-type register	0.0	—	0.0	—	0.0	—	ns
t _{HIR}	GLB register hold time after clock, input register path	1.0	—	1.0	—	1.3	—	ns
t _{HIRZ}	GLB register hold time after clock, input register path with zero hold	0.0	—	0.0	—	0.0	—	ns
t _{CO}	GLB register clock-to-output delay	—	3.0	—	3.2	—	3.5	ns
t _R	External reset pin to output delay	—	5.0	—	6.0	—	7.3	ns
t _{RW}	External reset pulse duration	1.5	—	1.7	—	2.0	—	ns
t _{P_{TOE/DIS}}	Input to output local product term output enable/disable	—	7.0	—	8.0	—	8.0	ns
t _{G_PTOE/DIS}	Input to output global product term output enable/disable	—	6.5	—	7.0	—	8.0	ns
t _{GOE/DIS}	Global OE input to output enable/disable	—	4.5	—	4.5	—	4.8	ns
t _{CW}	Global clock width, high or low	1.0	—	1.5	—	1.8	—	ns
t _{GW}	Global gate width low (for low transparent) or high (for high transparent)	1.0	—	1.5	—	1.8	—	ns
t _{WIR}	Input register clock width, high or low	1.0	—	1.5	—	1.8	—	ns
f _{MAX} ⁴	Clock frequency with internal feedback	—	267	—	250	—	220	MHz
f _{MAX} (Ext.)	clock frequency with external feedback, [1 / (t _S + t _{CO})]	—	192	—	175	—	161	MHz

1. Timing numbers are based on default LVCMOS 1.8 I/O buffers. Use timing adjusters provided to calculate other standards.

Timing v.2.2

2. Measured using standard switching GRP loading of 1 and 1 output switching.

3. Pulse widths and clock widths less than minimum will cause unknown behavior.

4. Standard 16-bit counter using GRP feedback.

Timing Model

The task of determining the timing through the ispMACH 4000 family, like any CPLD, is relatively simple. The timing model provided in Figure 11 shows the specific delay paths. Once the implementation of a given function is determined either conceptually or from the software report file, the delay path of the function can easily be determined from the timing model. The Lattice design tools report the timing delays based on the same timing model for a particular design. Note that the internal timing parameters are given for reference only, and are not tested. The external timing parameters are tested and guaranteed for every device. For more information on the timing model and usage, refer to TN1004, [ispMACH 4000 Timing Model Design and Usage Guidelines](#).

Figure 11. ispMACH 4000 Timing Model

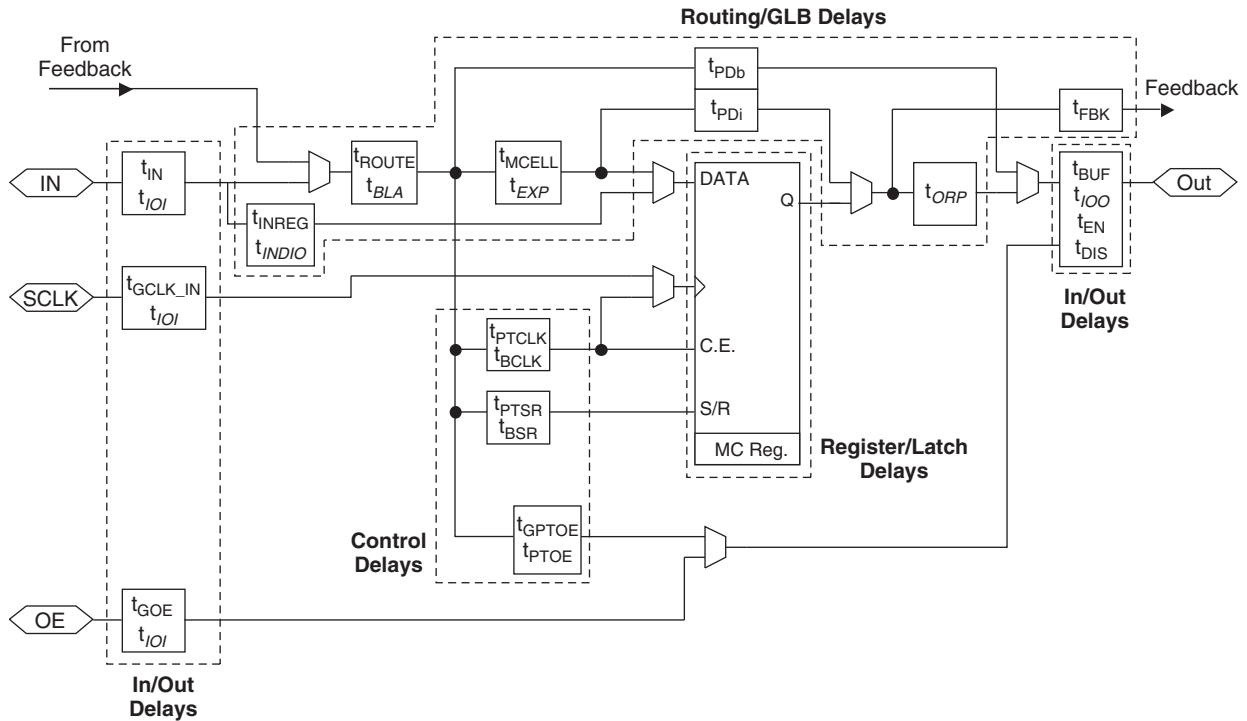

Note: Italicized items are optional delay adders.

ispMACH 4000V/B/C Timing Adders¹ (Cont.)

Adder Type	Base Parameter	Description	-5		-75		-10		Units
			Min.	Max.	Min.	Max.	Min.	Max.	
Optional Delay Adders									
t_{INDIO}	t_{INREG}	Input register delay	—	1.00	—	1.00	—	1.00	ns
t_{EXP}	t_{MCELL}	Product term expander delay	—	0.33	—	0.33	—	0.33	ns
t_{ORP}	—	Output routing pool delay	—	0.05	—	0.05	—	0.05	ns
t_{BLA}	t_{ROUTE}	Additional block loading adder	—	0.05	—	0.05	—	0.05	ns
t_{IOI} Input Adjusters									
LVTTTL_in	$t_{IN}, t_{GCLK_IN}, t_{GOE}$	Using LVTTTL standard	—	0.60	—	0.60	—	0.60	ns
LVC MOS33_in	$t_{IN}, t_{GCLK_IN}, t_{GOE}$	Using LVC MOS 3.3 standard	—	0.60	—	0.60	—	0.60	ns
LVC MOS25_in	$t_{IN}, t_{GCLK_IN}, t_{GOE}$	Using LVC MOS 2.5 standard	—	0.60	—	0.60	—	0.60	ns
LVC MOS18_in	$t_{IN}, t_{GCLK_IN}, t_{GOE}$	Using LVC MOS 1.8 standard	—	0.00	—	0.00	—	0.00	ns
PCI_in	$t_{IN}, t_{GCLK_IN}, t_{GOE}$	Using PCI compatible input	—	0.60	—	0.60	—	0.60	ns
t_{IOO} Output Adjusters									
LVTTTL_out	t_{BUF}, t_{EN}, t_{DIS}	Output configured as TTL buffer	—	0.20	—	0.20	—	0.20	ns
LVC MOS33_out	t_{BUF}, t_{EN}, t_{DIS}	Output configured as 3.3V buffer	—	0.20	—	0.20	—	0.20	ns
LVC MOS25_out	t_{BUF}, t_{EN}, t_{DIS}	Output configured as 2.5V buffer	—	0.10	—	0.10	—	0.10	ns
LVC MOS18_out	t_{BUF}, t_{EN}, t_{DIS}	Output configured as 1.8V buffer	—	0.00	—	0.00	—	0.00	ns
PCI_out	t_{BUF}, t_{EN}, t_{DIS}	Output configured as PCI compatible buffer	—	0.20	—	0.20	—	0.20	ns
Slow Slew	t_{BUF}, t_{EN}	Output configured for slow slew rate	—	1.00	—	1.00	—	1.00	ns

Note: Open drain timing is the same as corresponding LVC MOS timing.

Timing v.3.2

1. Refer to TN1004, [ispMACH 4000 Timing Model Design and Usage Guidelines](#) for information regarding use of these adders.

ispMACH 4000Z Timing Adders (Cont.)¹

Adder Type	Base Parameter	Description	-45		-5		-75		Units
			Min.	Max.	Min.	Max.	Min.	Max.	
Optional Delay Adders									
t _{INDIO}	t _{INREG}	Input register delay	—	1.30	—	1.30	—	1.30	ns
t _{EXP}	t _{MCELL}	Product term expander delay	—	0.45	—	0.45	—	0.50	ns
t _{ORP}	—	Output routing pool delay	—	0.40	—	0.40	—	0.40	ns
t _{BLA}	t _{ROUTE}	Additional block loading adder	—	0.05	—	0.05	—	0.05	ns
t_{IOI} Input Adjusters									
LVTTTL_in	t _{IN} , t _{GCLK_IN} , t _{GOE}	Using LVTTTL standard	—	0.60	—	0.60	—	0.60	ns
LVC MOS33_in	t _{IN} , t _{GCLK_IN} , t _{GOE}	Using LVC MOS 3.3 standard	—	0.60	—	0.60	—	0.60	ns
LVC MOS25_in	t _{IN} , t _{GCLK_IN} , t _{GOE}	Using LVC MOS 2.5 standard	—	0.60	—	0.60	—	0.60	ns
LVC MOS18_in	t _{IN} , t _{GCLK_IN} , t _{GOE}	Using LVC MOS 1.8 standard	—	0.00	—	0.00	—	0.00	ns
PCI_in	t _{IN} , t _{GCLK_IN} , t _{GOE}	Using PCI compatible input	—	0.60	—	0.60	—	0.60	ns
t_{IOO} Output Adjusters									
LVTTTL_out	t _{BUF} , t _{EN} , t _{DIS}	Output configured as TTL buffer	—	0.20	—	0.20	—	0.20	ns
LVC MOS33_out	t _{BUF} , t _{EN} , t _{DIS}	Output configured as 3.3V buffer	—	0.20	—	0.20	—	0.20	ns
LVC MOS25_out	t _{BUF} , t _{EN} , t _{DIS}	Output configured as 2.5V buffer	—	0.10	—	0.10	—	0.10	ns
LVC MOS18_out	t _{BUF} , t _{EN} , t _{DIS}	Output configured as 1.8V buffer	—	0.00	—	0.00	—	0.00	ns
PCI_out	t _{BUF} , t _{EN} , t _{DIS}	Output configured as PCI compatible buffer	—	0.20	—	0.20	—	0.20	ns
Slow Slew	t _{BUF} , t _{EN}	Output configured for slow slew rate	—	1.00	—	1.00	—	1.00	ns

Note: Open drain timing is the same as corresponding LVC MOS timing.

Timing v.2.2

1. Refer to TN1004, [ispMACH 4000 Timing Model Design and Usage Guidelines](#) for information regarding use of these adders.

Power Consumption

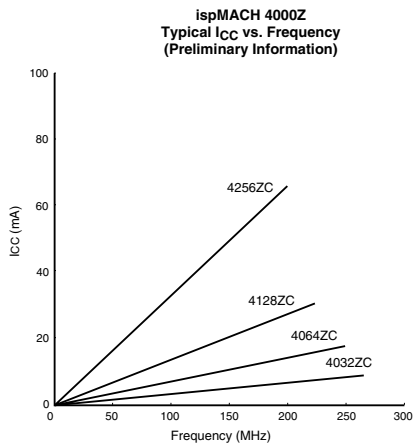

Note: The devices are configured with maximum number of 16-bit counters, typical current at 1.8V, 25°C.

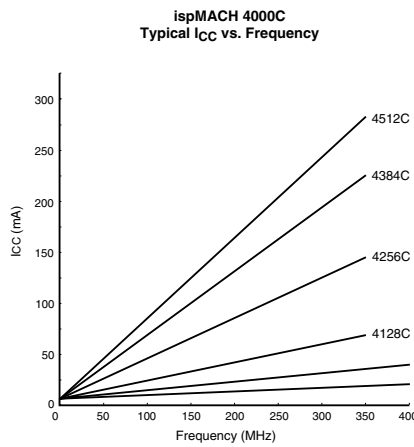

Note: The devices are configured with maximum number of 16-bit counters, typical current at 1.8V, 25°C.

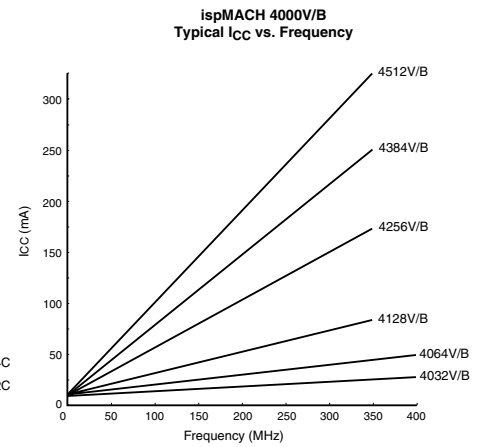

Note: The devices are configured with maximum number of 16-bit counters, typical current at 3.3V, 2.5V, 25°C.

Power Estimation Coefficients¹

Device	A	B
ispMACH 4032V/B	11.3	0.010
ispMACH 4032C	1.3	0.010
ispMACH 4064V/B	11.5	0.010
ispMACH 4064C	1.5	0.010
ispMACH 4128V/B	11.5	0.011
ispMACH 4128C	1.5	0.011
ispMACH 4256V/B	12	0.011
ispMACH 4256C	2	0.011
ispMACH 4384V/B	12.5	0.013
ispMACH 4384C	2.5	0.013
ispMACH 4512V/B	13	0.013
ispMACH 4512C	3	0.013
ispMACH 4032ZC	0.010	0.010
ispMACH 4064ZC	0.011	0.010
ispMACH 4128ZC	0.012	0.010
ispMACH 4256ZC	0.013	0.010

1. For further information about the use of these coefficients, refer to TN1005, [Power Estimation in ispMACH 4000V/B/C/Z Devices](#).

**ispMACH 4064V/B/C/Z, 4128V/B/C/Z, 4256V/B/C/Z Logic Signal Connections:
100-Pin TQFP (Cont.)**

Pin Number	Bank Number	ispMACH 4064V/B/C/Z		ispMACH 4128V/B/C/Z		ispMACH 4256V/B/C/Z	
		GLB/MC/Pad	ORP	GLB/MC/Pad	ORP	GLB/MC/Pad	ORP
42	1	C1	C^1	E2	E^1	I6	I^1
43	1	C2	C^2	E4	E^2	I10	I^2
44	1	C3	C^3	E6	E^3	I12	I^3
45	1	VCCO (Bank 1)	-	VCCO (Bank 1)	-	VCCO (Bank 1)	-
46	1	GND (Bank 1)	-	GND (Bank 1)	-	GND (Bank 1)	-
47	1	C4	C^4	E8	E^4	J2	J^0
48	1	C5	C^5	E10	E^5	J6	J^1
49	1	C6	C^6	E12	E^6	J10	J^2
50	1	C7	C^7	E14	E^7	J12	J^3
51	-	GND	-	GND	-	GND	-
52	-	TMS	-	TMS	-	TMS	-
53	1	C8	C^8	F0	F^0	K12	K^3
54	1	C9	C^9	F2	F^1	K10	K^2
55	1	C10	C^10	F4	F^2	K6	K^1
56	1	C11	C^11	F6	F^3	K2	K^0
57	1	GND (Bank 1)	-	GND (Bank 1)	-	GND (Bank 1)	-
58	1	C12	C^12	F8	F^4	L12	L^3
59	1	C13	C^13	F10	F^5	L10	L^2
60	1	C14	C^14	F12	F^6	L6	L^1
61	1	C15	C^15	F13	F^7	L4	L^0
62*	1	I	-	I	-	I	-
63	1	VCCO (Bank 1)	-	VCCO (Bank 1)	-	VCCO (Bank 1)	-
64	1	D15	D^15	G14	G^7	M4	M^0
65	1	D14	D^14	G12	G^6	M6	M^1
66	1	D13	D^13	G10	G^5	M10	M^2
67	1	D12	D^12	G8	G^4	M12	M^3
68	1	GND (Bank 1)	-	GND (Bank 1)	-	GND (Bank 1)	-
69	1	D11	D^11	G6	G^3	N2	N^0
70	1	D10	D^10	G5	G^2	N6	N^1
71	1	D9	D^9	G4	G^1	N10	N^2
72	1	D8	D^8	G2	G^0	N12	N^3
73*	1	I	-	I	-	I	-
74	-	TDO	-	TDO	-	TDO	-
75	-	VCC	-	VCC	-	VCC	-
76	-	GND	-	GND	-	GND	-
77*	1	I	-	I	-	I	-
78	1	D7	D^7	H13	H^7	O12	O^3
79	1	D6	D^6	H12	H^6	O10	O^2
80	1	D5	D^5	H10	H^5	O6	O^1
81	1	D4	D^4	H8	H^4	O2	O^0
82	1	GND (Bank 1)	-	GND (Bank 1)	-	GND (Bank 1)	-

**ispMACH 4064V/B/C/Z, 4128V/B/C/Z, 4256V/B/C/Z Logic Signal Connections:
100-Pin TQFP (Cont.)**

Pin Number	Bank Number	ispMACH 4064V/B/C/Z		ispMACH 4128V/B/C/Z		ispMACH 4256V/B/C/Z	
		GLB/MC/Pad	ORP	GLB/MC/Pad	ORP	GLB/MC/Pad	ORP
83	1	VCCO (Bank 1)	-	VCCO (Bank 1)	-	VCCO (Bank 1)	-
84	1	D3	D ³	H6	H ³	P12	P ³
85	1	D2	D ²	H4	H ²	P10	P ²
86	1	D1	D ¹	H2	H ¹	P6	P ¹
87	1	D0/GOE1	D ⁰	H0/GOE1	H ⁰	P2/OE1	P ⁰
88	1	CLK3/I	-	CLK3/I	-	CLK3/I	-
89	0	CLK0/I	-	CLK0/I	-	CLK0/I	-
90	-	VCC	-	VCC	-	VCC	-
91	0	A0/GOE0	A ⁰	A0/GOE0	A ⁰	A2/GOE0	A ⁰
92	0	A1	A ¹	A2	A ¹	A6	A ¹
93	0	A2	A ²	A4	A ²	A10	A ²
94	0	A3	A ³	A6	A ³	A12	A ³
95	0	VCCO (Bank 0)	-	VCCO (Bank 0)	-	VCCO (Bank 0)	-
96	0	GND (Bank 0)	-	GND (Bank 0)	-	GND (Bank 0)	-
97	0	A4	A ⁴	A8	A ⁴	B2	B ⁰
98	0	A5	A ⁵	A10	A ⁵	B6	B ¹
99	0	A6	A ⁶	A12	A ⁶	B10	B ²
100	0	A7	A ⁷	A14	A ⁷	B12	B ³

*This pin is input only.

ispMACH 4128V/B/C Logic Signal Connections: 128-Pin TQFP

Pin Number	Bank Number	ispMACH 4128V/B/C	
		GLB/MC/Pad	ORP
1	0	GND	-
2	0	TDI	-
3	0	VCCO (Bank 0)	-
4	0	B0	B ⁰
5	0	B1	B ¹
6	0	B2	B ²
7	0	B4	B ³
8	0	B5	B ⁴
9	0	B6	B ⁵
10	0	GND (Bank 0)	-
11	0	B8	B ⁶
12	0	B9	B ⁷
13	0	B10	B ⁸
14	0	B12	B ⁹
15	0	B13	B ¹⁰
16	0	B14	B ¹¹
17	0	VCCO (Bank 0)	-
18	0	C14	C ¹¹

ispMACH 4064Z, 4128Z and 4256Z Logic Signal Connections: 132-Ball csBGA (Cont.)

Ball Number	Bank Number	ispMACH 4064Z		ispMACH 4128Z		ispMACH 4256Z	
		GLB/MC/Pad	ORP	GLB/MC/Pad	ORP	GLB/MC/Pad	ORP
D13	1	D10	D ¹⁰	G4	G ³	N6	N ³
D14	1	D9	D ⁹	G2	G ²	N8	N ⁴
D12	1	D8	D ⁸	G1	G ¹	N10	N ⁵
C14	1	I	-	G0	G ⁰	N12	N ⁶
C13	1	NC	-	VCCO (Bank 1)	-	VCCO (Bank 1)	-
B14	-	TDO	-	TDO	-	TDO	-
A14	-	VCC	-	VCC	-	VCC	-
A13	-	GND	-	GND	-	GND	-
B13	1	NC	-	H14	H ¹¹	O12	O ⁶
A12	1	I	-	H13	H ¹⁰	O10	O ⁵
C12	1	D7	D ⁷	H12	H ⁹	O8	O ⁴
B12	1	D6	D ⁶	H10	H ⁸	O6	O ³
A11	1	D5	D ⁵	H9	H ⁷	O4	O ²
C11	1	D4	D ⁴	H8	H ⁶	O2	O ¹
B11	1	GND (Bank 1)	-	GND (Bank 1)	-	GND (Bank 1)	-
A10	1	VCCO (Bank 1)	-	VCCO (Bank 1)	-	VCCO (Bank 1)	-
B10	1	NC	-	H6	H ⁵	P12	P ⁶
C10	1	NC	-	H5	H ⁴	P10	P ⁵
B9	1	D3	D ³	H4	H ³	P8	P ⁴
A9	1	D2	D ²	H2	H ²	P6	P ³
C9	1	D1	D ¹	H1	H ¹	P4	P ²
A8	1	D0/GOE1	D ⁰	H0/GOE1	H ⁰	P2/GOE1	P ¹
B8	1	CLK3/I	-	CLK3/I	-	CLK3/I	-
C8	0	CLK0/I	-	CLK0/I	-	CLK0/I	-
B7	-	VCC	-	VCC	-	VCC	-
A7	0	NC ¹	-	NC ¹	-	I ¹	-
C7	0	A0/GOE0	A ⁰	A0/GOE0	A ⁰	A2/GOE0	A ¹
A6	0	A1	A ¹	A1	A ¹	A4	A ²
B6	0	A2	A ²	A2	A ²	A6	A ³
C6	0	A3	A ³	A4	A ³	A8	A ⁴
B5	0	NC	-	A5	A ⁴	A10	A ⁵
A5	0	NC	-	A6	A ⁵	A12	A ⁶
C5	0	VCCO (Bank 0)	-	VCCO (Bank 0)	-	VCCO (Bank 0)	-
B4	0	GND (Bank 0)	-	GND (Bank 0)	-	GND (Bank 0)	-
A4	0	NC	-	A8	A ⁶	B2	B ¹
C4	0	A4	A ⁴	A9	A ⁷	B4	B ²
A3	0	A5	A ⁵	A10	A ⁸	B6	B ³
B3	0	A6	A ⁶	A12	A ⁹	B8	B ⁴
A2	0	A7	A ⁷	A13	A ¹⁰	B10	B ⁵
A1	0	NC	-	A14	A ¹¹	B12	B ⁶

1. For device migration considerations, these NC pins are input signal pins in ispMACH 4256Z device.

ispMACH 4128V and 4256V Logic Signal Connections: 144-Pin TQFP (Cont.)

Pin Number	Bank Number	ispMACH 4128V		ispMACH 4256V	
		GLB/MC/Pad	ORP	GLB/MC/Pad	ORP
86	1	F12	F ⁹	L8	L ⁴
87	1	F13	F ¹⁰	L6	L ³
88	1	F14	F ¹¹	L4	L ²
89	1	NC ²	-	I ²	-
90	1	GND (Bank 1) ¹	-	NC ¹	-
91	1	VCCO (Bank 1)	-	VCCO (Bank 1)	-
92	1	NC ²	-	I ²	-
93	1	G14	G ¹¹	M2	M ¹
94	1	G13	G ¹⁰	M4	M ²
95	1	G12	G ⁹	M6	M ³
96	1	G10	G ⁸	M8	M ⁴
97	1	G9	G ⁷	M10	M ⁵
98	1	G8	G ⁶	M12	M ⁶
99	1	GND (Bank 1)	-	GND (Bank 1)	-
100	1	G6	G ⁵	N2	N ¹
101	1	G5	G ⁴	N4	N ²
102	1	G4	G ³	N6	N ³
103	1	G2	G ²	N8	N ⁴
104	1	G1	G ¹	N10	N ⁵
105	1	G0	G ⁰	N12	N ⁶
106	1	VCCO (Bank 1)	-	VCCO (Bank 1)	-
107	-	TDO	-	TDO	-
108	-	VCC	-	VCC	-
109	-	GND	-	GND	-
110	1	NC ²	-	I ²	-
111	1	H14	H ¹¹	O12	O ⁶
112	1	H13	H ¹⁰	O10	O ⁵
113	1	H12	H ⁹	O8	O ⁴
114	1	H10	H ⁸	O6	O ³
115	1	H9	H ⁷	O4	O ²
116	1	H8	H ⁶	O2	O ¹
117	1	NC ²	-	I ²	-
118	1	GND (Bank 1)	-	GND (Bank 1)	-
119	1	VCCO (Bank 1)	-	VCCO (Bank 1)	-
120	1	H6	H ⁵	P12	P ⁶
121	1	H5	H ⁴	P10	P ⁵
122	1	H4	H ³	P8	P ⁴
123	1	H2	H ²	P6	P ³
124	1	H1	H ¹	P4	P ²
125	1	H0/GOE1	H ⁰	P2/GOE1	P ¹
126	1	CLK3/I	-	CLK3/I	-
127	0	GND (Bank 0)	-	GND (Bank 0)	-
128	0	CLK0/I	-	CLK0/I	-

**ispMACH 4256V/B/C/Z, 4384V/B/C, 4512V/B/C, Logic Signal Connections:
176-Pin TQFP (Cont.)**

Pin Number	Bank Number	ispMACH 4256V/B/C/Z		ispMACH 4384V/B/C		ispMACH 4512V/B/C	
		GLB/MC/Pad	ORP	GLB/MC/Pad	ORP	GLB/MC/Pad	ORP
142	1	O0	O^0	GX0	GX^0	OX0	OX^0
143	1	GND (Bank 1)	-	GND (Bank 1)	-	GND (Bank 1)	-
144	1	VCCO (Bank 1)	-	VCCO (Bank 1)	-	VCCO (Bank 1)	-
145	1	P14	P^7	HX14	HX^7	PX14	PX^7
146	1	P12	P^6	HX12	HX^6	PX12	PX^6
147	1	P10	P^5	HX10	HX^5	PX10	PX^5
148	1	P8	P^4	HX8	HX^4	PX8	PX^4
149	1	P6	P^3	HX6	HX^3	PX6	PX^3
150	1	P4	P^2	HX4	HX^2	PX4	PX^2
151	1	P2/GOE1	P^1	HX2/GOE1	HX^1	PX2/GOE1	PX^1
152	1	P0	P^0	HX0	HX^0	PX0	PX^0
153	-	GND	-	GND	-	GND	-
154	1	CLK3/I	-	CLK3/I	-	CLK3/I	-
155	0	GND (Bank 0)	-	GND (Bank 0)	-	GND (Bank 0)	-
156	0	CLK0/I	-	CLK0/I	-	CLK0/I	-
157	-	VCC	-	VCC	-	VCC	-
158	0	A0	A^0	A0	A^0	A0	A^0
159	0	A2/GOE0	A^1	A2/GOE0	A^1	A2/GOE0	A^1
160	0	A4	A^2	A4	A^2	A4	A^2
161	0	A6	A^3	A6	A^3	A6	A^3
162	0	A8	A^4	A8	A^4	A8	A^4
163	0	A10	A^5	A10	A^5	A10	A^5
164	0	A12	A^6	A12	A^6	A12	A^6
165	0	A14	A^7	A14	A^7	A14	A^7
166	0	VCCO (Bank 0)	-	VCCO (Bank 0)	-	VCCO (Bank 0)	-
167	0	GND (Bank 0)	-	GND (Bank 0)	-	GND (Bank 0)	-
168	0	B0	B^0	B0	B^0	B0	B^0
169	0	B2	B^1	B2	B^1	B2	B^1
170	0	B4	B^2	B4	B^2	B4	B^2
171	0	B6	B^3	B6	B^3	B6	B^3
172	0	B8	B^4	B8	B^4	B8	B^4
173	0	B10	B^5	B10	B^5	B10	B^5
174	0	B12	B^6	B12	B^6	B12	B^6
175	0	B14	B^7	B14	B^7	B14	B^7
176	-	VCC	-	VCC	-	VCC	-

**ispMACH 4256V/B/C, 4384V/B/C, 4512V/B/C Logic Signal Connections:
256-Ball ftBGA/fpBGA (Cont.)**

Ball Number	I/O Bank	ispMACH 4256V/B/C 128-I/O		ispMACH 4256V/B/C 160-I/O		ispMACH 4384V/B/C		ispMACH 4512V/B/C	
		GLB/MC/Pad	ORP	GLB/MC/Pad	ORP	GLB/MC/Pad	ORP	GLB/MC/Pad	ORP
C12	1	O0	O^0	O2	O^2	GX0	GX^0	OX0	OX^0
E10	1	NC	-	O1	O^1	CX8	CX^4	MX0	MX^0
A13	1	NC	-	O0	O^0	CX10	CX^5	MX4	MX^1
D12	1	NC	-	NC	-	NC	-	LX0	LX^0
-	1	GND (Bank 1)	-	GND (Bank 1)	-	GND (Bank 1)	-	GND (Bank 1)	-
-	1	VCCO (Bank 1)	-	VCCO (Bank 1)	-	VCCO (Bank 1)	-	VCCO (Bank 1)	-
B12	1	NC	-	NC	-	NC	-	LX4	LX^1
A12	1	NC	-	NC	-	EX2	EX^1	LX8	LX^2
B11	1	NC	-	NC	-	EX0	EX^0	LX12	LX^3
A11	1	NC	-	P14	P^9	CX12	CX^6	MX8	MX^2
D10	1	NC	-	P12	P^8	CX14	CX^7	MX12	MX^3
C10	1	P14	P^7	P10	P^7	HX14	HX^7	PX14	PX^7
B10	1	P12	P^6	P9	P6	HX12	HX^6	PX12	PX^6
A10	1	P10	P^5	P8	P^5	HX10	HX^5	PX10	PX^5
A9	1	P8	P^4	P6	P^4	HX8	HX^4	PX8	PX^4
F9	1	P6	P^3	P4	P^3	HX6	HX^3	PX6	PX^3
B9	1	P4	P^2	P2	P^2	HX4	HX^2	PX4	PX^2
E9	1	P2/GOE1	P^1	P1/GOE1	P^1	HX2/GOE1	HX^1	PX2/GOE1	PX^1
C9	1	P0	P^0	P0	P^0	HX0	HX^0	PX0	PX^0
-	-	GND	-	GND	-	GND	-	GND	-
D9	1	CLK3/I	-	CLK3/I	-	CLK3/I	-	CLK3/I	-
-	0	GND (Bank 0)	-	GND (Bank 0)	-	GND (Bank 0)	-	GND (Bank 0)	-
B8	0	CLK0/I	-	CLK0/I	-	CLK0/I	-	CLK0/I	-
-	-	VCC	-	VCC	-	VCC	-	VCC	-
D8	0	A0	A^0	A0	A^0	A0	A^0	A0	A^0
C8	0	A2/GOE0	A^1	A1/GOE0	A^1	A2/GOE0	A^1	A2/GOE0	A^1
A8	0	A4	A^2	A2	A^2	A4	A^2	A4	A^2
A7	0	A6	A^3	A4	A^3	A6	A^3	A6	A^3
B7	0	A8	A^4	A6	A^4	A8	A^4	A8	A^4
E8	0	A10	A^5	A8	A^5	A10	A^5	A10	A^5
D7	0	A12	A^6	A9	A^6	A12	A^6	A12	A^6
F8	0	A14	A^7	A10	A^7	A14	A^7	A14	A^7
C7	0	NC	-	A12	A^8	F14	F^7	D0	D^0
A6	0	NC	-	A14	A^9	F12	F^6	D4	D^1
B6	0	NC	-	NC	-	D14	D^7	E0	E^0
A5	0	NC	-	NC	-	D12	D^6	E4	E^1
B5	0	NC	-	NC	-	NC	-	E8	E^2
-	0	VCCO (Bank 0)	-	VCCO (Bank 0)	-	VCCO (Bank 0)	-	VCCO (Bank 0)	-
-	0	GND (Bank 0)	-	GND (Bank 0)	-	GND (Bank 0)	-	GND (Bank 0)	-
D5	0	NC	-	NC	-	NC	-	E12	E^3
A4	0	NC	-	B0	B^0	F10	F^5	D8	D^2

ispMACH 4000B (2.5V) Industrial Devices (Cont.)

Family	Part Number	Macrocells	Voltage	t _{PD}	Package	Pin/Ball Count	I/O	Grade
LC4384B	LC4384B-5FT256I	384	2.5	5	ftBGA	256	192	I
	LC4384B-75FT256I	384	2.5	7.5	ftBGA	256	192	I
	LC4384B-10FT256I	384	2.5	10	ftBGA	256	192	I
	LC4384B-5F256I ¹	384	2.5	5	fpBGA	256	192	I
	LC4384B-75F256I ¹	384	2.5	7.5	fpBGA	256	192	I
	LC4384B-10F256I ¹	384	2.5	10	fpBGA	256	192	I
	LC4384B-5T176I	384	2.5	5	TQFP	176	128	I
	LC4384B-75T176I	384	2.5	7.5	TQFP	176	128	I
	LC4384B-10T176I	384	2.5	10	TQFP	176	128	I
LC4512B	LC4512B-5FT256I	512	2.5	5	ftBGA	256	208	I
	LC4512B-75FT256I	512	2.5	7.5	ftBGA	256	208	I
	LC4512B-10FT256I	512	2.5	10	ftBGA	256	208	I
	LC4512B-5F256I ¹	512	2.5	5	fpBGA	256	208	I
	LC4512B-75F256I ¹	512	2.5	7.5	fpBGA	256	208	I
	LC4512B-10F256I ¹	512	2.5	10	fpBGA	256	208	I
	LC4512B-5T176I	512	2.5	5	TQFP	176	128	I
	LC4512B-75T176I	512	2.5	7.5	TQFP	176	128	I
	LC4512B-10T176I	512	2.5	10	TQFP	176	128	I

1. Use ftBGA package. fpBGA package devices have been discontinued via PCN#14A-07.

ispMACH 4000V (3.3V) Commercial Devices

Device	Part Number	Macrocells	Voltage	t _{PD}	Package	Pin/Ball Count	I/O	Grade
LC4032V	LC4032V-25T48C	32	3.3	2.5	TQFP	48	32	C
	LC4032V-5T48C	32	3.3	5	TQFP	48	32	C
	LC4032V-75T48C	32	3.3	7.5	TQFP	48	32	C
	LC4032V-25T44C	32	3.3	2.5	TQFP	44	30	C
	LC4032V-5T44C	32	3.3	5	TQFP	44	30	C
	LC4032V-75T44C	32	3.3	7.5	TQFP	44	30	C
LC4064V	LC4064V-25T100C	64	3.3	2.5	TQFP	100	64	C
	LC4064V-5T100C	64	3.3	5	TQFP	100	64	C
	LC4064V-75T100C	64	3.3	7.5	TQFP	100	64	C
	LC4064V-25T48C	64	3.3	2.5	TQFP	48	32	C
	LC4064V-5T48C	64	3.3	5	TQFP	48	32	C
	LC4064V-75T48C	64	3.3	7.5	TQFP	48	32	C
	LC4064V-25T44C	64	3.3	2.5	TQFP	44	30	C
	LC4064V-5T44C	64	3.3	5	TQFP	44	30	C
	LC4064V-75T44C	64	3.3	7.5	TQFP	44	30	C

Lead-Free Packaging**ispMACH 4000Z (Zero Power, 1.8V) Lead-Free Commercial Devices**

Device	Part Number	Macrocells	Voltage	t _{PD}	Package	Pin/Ball Count	I/O	Grade
LC4032ZC	LC4032ZC-35MN56C	32	1.8	3.5	Lead-free csBGA	56	32	C
	LC4032ZC-5MN56C	32	1.8	5	Lead-free csBGA	56	32	C
	LC4032ZC-75MN56C	32	1.8	7.5	Lead-free csBGA	56	32	C
	LC4032ZC-35TN48C	32	1.8	3.5	Lead-free TQFP	48	32	C
	LC4032ZC-5TN48C	32	1.8	5	Lead-free TQFP	48	32	C
	LC4032ZC-75TN48C	32	1.8	7.5	Lead-free TQFP	48	32	C
LC4064ZC	LC4064ZC-37MN132C	64	1.8	3.7	Lead-free csBGA	132	64	C
	LC4064ZC-5MN132C	64	1.8	5	Lead-free csBGA	132	64	C
	LC4064ZC-75MN132C	64	1.8	7.5	Lead-free csBGA	132	64	C
	LC4064ZC-37TN100C	64	1.8	3.7	Lead-free TQFP	100	64	C
	LC4064ZC-5TN100C	64	1.8	5	Lead-free TQFP	100	64	C
	LC4064ZC-75TN100C	64	1.8	7.5	Lead-free TQFP	100	64	C
	LC4064ZC-37MN56C	64	1.8	3.7	Lead-free csBGA	56	32	C
	LC4064ZC-5MN56C	64	1.8	5	Lead-free csBGA	56	32	C
	LC4064ZC-75MN56C	64	1.8	7.5	Lead-free csBGA	56	32	C
	LC4064ZC-37TN48C	64	1.8	3.7	Lead-free TQFP	48	32	C
	LC4064ZC-5TN48C	64	1.8	5	Lead-free TQFP	48	32	C
	LC4064ZC-75TN48C	64	1.8	7.5	Lead-free TQFP	48	32	C
LC4128ZC	LC4128ZC-42MN132C	128	1.8	4.2	Lead-free csBGA	132	96	C
	LC4128ZC-75MN132C	128	1.8	7.5	Lead-free csBGA	132	96	C
	LC4128ZC-42TN100C	128	1.8	4.2	Lead-free TQFP	100	64	C
	LC4128ZC-75TN100C	128	1.8	7.5	Lead-free TQFP	100	64	C
LC4256ZC	LC4256ZC-45TN176C	256	1.8	4.5	Lead-free TQFP	176	128	C
	LC4256ZC-75TN176C	256	1.8	7.5	Lead-free TQFP	176	128	C
	LC4256ZC-45MN132C	256	1.8	4.5	Lead-free csBGA	132	96	C
	LC4256ZC-75MN132C	256	1.8	7.5	Lead-free csBGA	132	96	C
	LC4256ZC-45TN100C	256	1.8	4.5	Lead-free TQFP	100	64	C
	LC4256ZC-75TN100C	256	1.8	7.5	Lead-free TQFP	100	64	C

ispMACH 4000Z (Zero Power, 1.8V) Lead-Free Industrial Devices

Device	Part Number	Macrocells	Voltage	t _{PD}	Package	Pin/Ball Count	I/O	Grade
LC4032ZC	LC4032ZC-5MN56I	32	1.8	5	Lead-free csBGA	56	32	I
	LC4032ZC-75MN56I	32	1.8	7.5	Lead-free csBGA	56	32	I
	LC4032ZC-5TN48I	32	1.8	5	Lead-free TQFP	48	32	I
	LC4032ZC-75TN48I	32	1.8	7.5	Lead-free TQFP	48	32	I

ispMACH 4000C (1.8V) Lead-Free Commercial Devices (Cont.)

Device	Part Number	Macrocells	Voltage	t _{PD}	Package	Pin/Ball Count	I/O	Grade
LC4064C	LC4064C-25TN100C	64	1.8	2.5	Lead-free TQFP	100	64	C
	LC4064C-5TN100C	64	1.8	5	Lead-free TQFP	100	64	C
	LC4064C-75TN100C	64	1.8	7.5	Lead-free TQFP	100	64	C
	LC4064C-25TN48C	64	1.8	2.5	Lead-free TQFP	48	32	C
	LC4064C-5TN48C	64	1.8	5	Lead-free TQFP	48	32	C
	LC4064C-75TN48C	64	1.8	7.5	Lead-free TQFP	48	32	C
	LC4064C-25TN44C	64	1.8	2.5	Lead-free TQFP	44	30	C
	LC4064C-5TN44C	64	1.8	5	Lead-free TQFP	44	30	C
LC4128C	LC4128C-27TN128C	128	1.8	2.7	Lead-free TQFP	128	92	C
	LC4128C-5TN128C	128	1.8	5	Lead-free TQFP	128	92	C
	LC4128C-75TN128C	128	1.8	7.5	Lead-free TQFP	128	92	C
	LC4128C-27TN100C	128	1.8	2.7	Lead-free TQFP	100	64	C
	LC4128C-5TN100C	128	1.8	5	Lead-free TQFP	100	64	C
	LC4128C-75TN100C	128	1.8	7.5	Lead-free TQFP	100	64	C
LC4256C	LC4256C-3FTN256AC	256	1.8	3	Lead-free ftBGA	256	128	C
	LC4256C-5FTN256AC	256	1.8	5	Lead-free ftBGA	256	128	C
	LC4256C-75FTN256AC	256	1.8	7.5	Lead-free ftBGA	256	128	C
	LC4256C-3FTN256BC	256	1.8	3	Lead-free ftBGA	256	160	C
	LC4256C-5FTN256BC	256	1.8	5	Lead-free ftBGA	256	160	C
	LC4256C-75FTN256BC	256	1.8	7.5	Lead-free ftBGA	256	160	C
	LC4256C-3FN256AC ¹	256	1.8	3	Lead-free fpBGA	256	128	C
	LC4256C-5FN256AC ¹	256	1.8	5	Lead-free fpBGA	256	128	C
	LC4256C-75FN256AC ¹	256	1.8	7.5	Lead-free fpBGA	256	128	C
	LC4256C-3FN256BC ¹	256	1.8	3	Lead-free fpBGA	256	160	C
	LC4256C-5FN256BC ¹	256	1.8	5	Lead-free fpBGA	256	160	C
	LC4256C-75FN256BC ¹	256	1.8	7.5	Lead-free fpBGA	256	160	C
	LC4256C-3TN176C	256	1.8	3	Lead-free TQFP	176	128	C
	LC4256C-5TN176C	256	1.8	5	Lead-free TQFP	176	128	C
	LC4256C-75TN176C	256	1.8	7.5	Lead-free TQFP	176	128	C
	LC4256C-3TN100C	256	1.8	3	Lead-free TQFP	100	64	C
LC4256C-5TN100C	256	1.8	5	Lead-free TQFP	100	64	C	
LC4256C-75TN100C	256	1.8	7.5	Lead-free TQFP	100	64	C	
LC4384C	LC4384C-35FTN256C	384	1.8	3.5	Lead-free ftBGA	256	192	C
	LC4384C-5FTN256C	384	1.8	5	Lead-free ftBGA	256	192	C
	LC4384C-75FTN256C	384	1.8	7.5	Lead-free ftBGA	256	192	C
	LC4384C-35FN256C ¹	384	1.8	3.5	Lead-free fpBGA	256	192	C
	LC4384C-5FN256C ¹	384	1.8	5	Lead-free fpBGA	256	192	C
	LC4384C-75FN256C ¹	384	1.8	7.5	Lead-free fpBGA	256	192	C
	LC4384C-35TN176C	384	1.8	3.5	Lead-free TQFP	176	128	C
	LC4384C-5TN176C	384	1.8	5	Lead-free TQFP	176	128	C
LC4384C-75TN176C	384	1.8	7.5	Lead-free TQFP	176	128	C	

ispMACH 4000V (3.3V) Lead-Free Extended Temperature Devices

Device	Part Number	Macrocells	Voltage	t _{PD}	Package	Pin/Ball Count	I/O	Grade
LC4032V	LC4032V-75TN48E	32	3.3	7.5	Lead-free TQFP	48	32	E
	LC4032V-75TN44E	32	3.3	7.5	Lead-free TQFP	44	30	E
LC4064V	LC4064V-75TN100E	64	3.3	7.5	Lead-free TQFP	100	64	E
	LC4064V-75TN48E	64	3.3	7.5	Lead-free TQFP	48	32	E
	LC4064V-75TN44E	64	3.3	7.5	Lead-free TQFP	44	30	E
LC4128V	LC4128V-75TN144E	128	3.3	7.5	Lead-free TQFP	144	96	E
	LC4128V-75TN128E	128	3.3	7.5	Lead-free TQFP	128	92	E
	LC4128V-75TN100E	128	3.3	7.5	Lead-free TQFP	100	64	E
LC4256V	LC4256V-75TN176E	256	3.3	7.5	Lead-free TQFP	176	128	E
	LC4256V-75TN144E	256	3.3	7.5	Lead-free TQFP	144	96	E
	LC4256V-75TN100E	256	3.3	7.5	Lead-free TQFP	100	64	E

For Further Information

In addition to this data sheet, the following technical notes may be helpful when designing with the ispMACH 4000V/B/C/Z family:

- TN1004, [ispMACH 4000 Timing Model Design and Usage Guidelines](#)
- TN1005, [Power Estimation in ispMACH 4000V/B/C/Z Devices](#)

Revision History

Date	Version	Change Summary
—	—	Previous Lattice releases.
July 2003	17z	Changed device status for LC4064ZC and LC4128ZC to production release and updated/added AC and DC parameters as well as ordering part numbers for LC4064ZC and LC4128ZC devices.
		Improved leakage current specifications for ispMACH 4000Z. For ispMACH 4000V/B/C IIL, IIH condition now includes 0V and 3.6V end points ($0 \leq V_{IN} \leq 3.6V$).
		Added 132-ball chip scale BGA power supply and NC connections.
		Added 132-ball chip scale BGA logic signal connections for LC4064ZC, LC4128ZC and LC4256ZC devices.
		Added lead-free package designators.
October 2003	18z	Hot socketing characteristics footnote 1. has been enhanced; Insensitive to sequence of VCC or VCCO. However, assumes monotonic rise/fall rates for Vcc and Vcco, provided ($V_{IN} - V_{CCO}$) \leq 3.6V.
		Improved LC4064ZC t _S to 2.5ns, t _{ST} to 2.7ns and f _{MAX} (Ext.) to 175MHz, LC4128ZC t _{CO} to 3.5ns and f _{MAX} (Ext.) to 161MHz (version v.2.1).
		Improved associated internal timing numbers and timing adders (version v.2.1).
		Added ispMACH 4000V/B/C/Z ORP Reference Tables.
		Enhanced ORP information in device pinout tables consistent with the ORP Combinations for I/O Blocks tables (table 6, 7, 8 and 9 in page 9-11).
		Corrected GLB/MC/Pad information in the 256-fpBGA pinouts for the LC4256V/B/C 160-I/O version.
		Added the ispMACH 4000 Family Speed Grade Offering table.
		Added the ispMACH 4128ZC Industrial and Automotive Device OPNs
December 2003	19z	Added the ispMACH 4032ZC and 4064ZC Industrial and Automotive Device OPNs