

Welcome to E-XFL.COM

Understanding [Embedded - CPLDs \(Complex Programmable Logic Devices\)](#)

Embedded - CPLDs, or Complex Programmable Logic Devices, are highly versatile digital logic devices used in electronic systems. These programmable components are designed to perform complex logical operations and can be customized for specific applications. Unlike fixed-function ICs, CPLDs offer the flexibility to reprogram their configuration, making them an ideal choice for various embedded systems. They consist of a set of logic gates and programmable interconnects, allowing designers to implement complex logic circuits without needing custom hardware.

Applications of Embedded - CPLDs

Details

Product Status	Active
Programmable Type	In System Programmable
Delay Time tpd(1) Max	7.5 ns
Voltage Supply - Internal	1.7V ~ 1.9V
Number of Logic Elements/Blocks	4
Number of Macrocells	64
Number of Gates	-
Number of I/O	64
Operating Temperature	0°C ~ 90°C (TJ)
Mounting Type	Surface Mount
Package / Case	132-LFBGA, CSPBGA
Supplier Device Package	132-CSBGA (8x8)
Purchase URL	https://www.e-xfl.com/product-detail/lattice-semiconductor/lc4064zc-75mn132c

Table 5. Product Term Expansion Capability

Expansion Chains	Macrocells Associated with Expansion Chain (with Wrap Around)	Max PT/Macrocell
Chain-0	M0 M4 M8 M12 M0	75
Chain-1	M1 M5 M9 M13 M1	80
Chain-2	M2 M6 M10 M14 M2	75
Chain-3	M3 M7 M11 M15 M3	70

Every time the super cluster allocator is used, there is an incremental delay of t_{EXP} . When the super cluster allocator is used, all destinations other than the one being steered to, are given the value of ground (i.e., if the super cluster is steered to M (n+4), then M (n) is ground).

Macrocell

The 16 macrocells in the GLB are driven by the 16 outputs from the logic allocator. Each macrocell contains a programmable XOR gate, a programmable register/latch, along with routing for the logic and control functions. Figure 5 shows a graphical representation of the macrocell. The macrocells feed the ORP and GRP. A direct input from the I/O cell allows designers to use the macrocell to construct high-speed input registers. A programmable delay in this path allows designers to choose between the fastest possible set-up time and zero hold time.

Figure 5. Macrocell

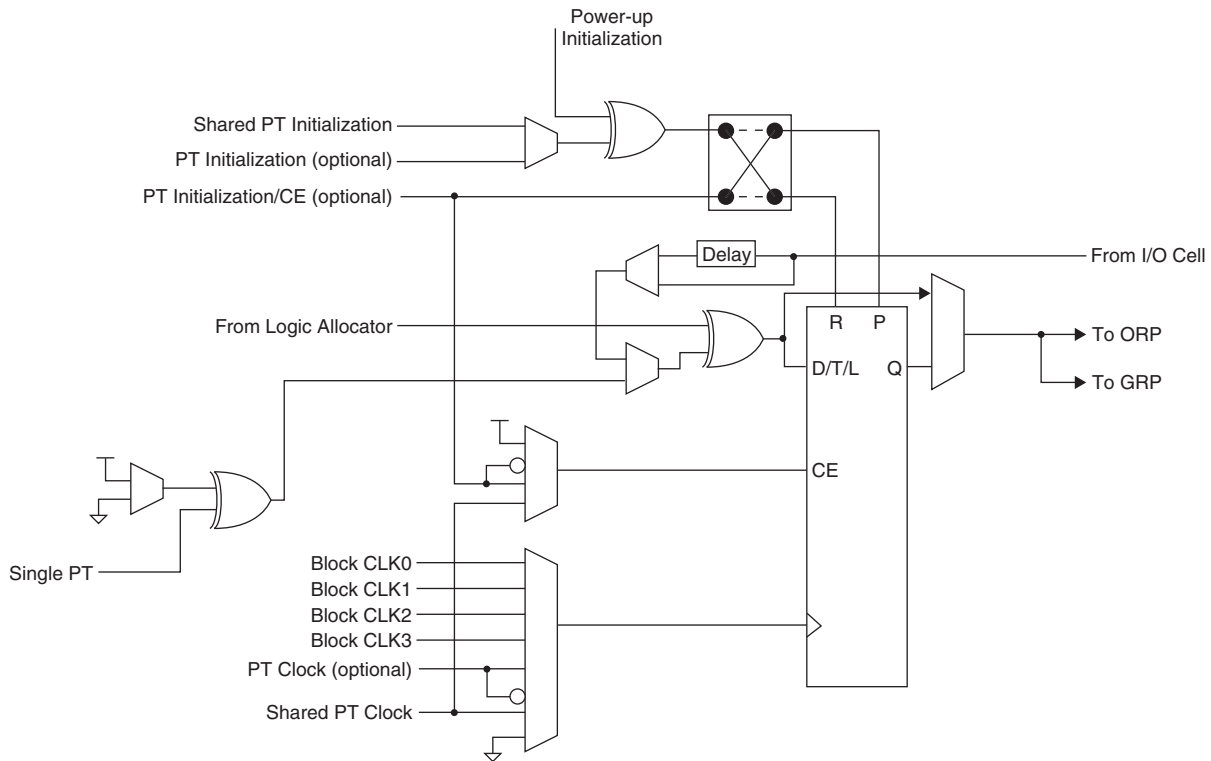

Enhanced Clock Multiplexer

The clock input to the flip-flop can select any of the four block clocks along with the shared PT clock, and true and complement forms of the optional individual term clock. An 8:1 multiplexer structure is used to select the clock. The eight sources for the clock multiplexer are as follows:

- Block CLK0
- Block CLK1

Table 7. ORP Combinations for I/O Blocks with 16 I/Os

I/O Cell	Available Macrocells
I/O 0	M0, M1, M2, M3, M4, M5, M6, M7
I/O 1	M1, M2, M3, M4, M5, M6, M7, M8
I/O 2	M2, M3, M4, M5, M6, M7, M8, M9
I/O 3	M3, M4, M5, M6, M7, M8, M9, M10
I/O 4	M4, M5, M6, M7, M8, M9, M10, M11
I/O 5	M5, M6, M7, M8, M9, M10, M11, M12
I/O 6	M6, M7, M8, M9, M10, M11, M12, M13
I/O 7	M7, M8, M9, M10, M11, M12, M13, M14
I/O 8	M8, M9, M10, M11, M12, M13, M14, M15
I/O 9	M9, M10, M11, M12, M13, M14, M15, M0
I/O 10	M10, M11, M12, M13, M14, M15, M0, M1
I/O 11	M11, M12, M13, M14, M15, M0, M1, M2
I/O 12	M12, M13, M14, M15, M0, M1, M2, M3
I/O 13	M13, M14, M15, M0, M1, M2, M3, M4
I/O 14	M14, M15, M0, M1, M2, M3, M4, M5
I/O 15	M15, M0, M1, M2, M3, M4, M5, M6

Table 8. ORP Combinations for I/O Blocks with 4 I/Os

I/O Cell	Available Macrocells
I/O 0	M0, M1, M2, M3, M4, M5, M6, M7
I/O 1	M4, M5, M6, M7, M8, M9, M10, M11
I/O 2	M8, M9, M10, M11, M12, M13, M14, M15
I/O 3	M12, M13, M14, M15, M0, M1, M2, M3

Table 9. ORP Combinations for I/O Blocks with 10 I/Os

I/O Cell	Available Macrocells
I/O 0	M0, M1, M2, M3, M4, M5, M6, M7
I/O 1	M2, M3, M4, M5, M6, M7, M8, M9
I/O 2	M4, M5, M6, M7, M8, M9, M10, M11
I/O 3	M6, M7, M8, M9, M10, M11, M12, M13
I/O 4	M8, M9, M10, M11, M12, M13, M14, M15
I/O 5	M10, M11, M12, M13, M14, M15, M0, M1
I/O 6	M12, M13, M14, M15, M0, M1, M2, M3
I/O 7	M14, M15, M0, M1, M2, M3, M4, M5
I/O 8	M2, M3, M4, M5, M6, M7, M8, M9
I/O 9	M10, M11, M12, M13, M14, M15, M0, M1

- LVTTTL
- LVC MOS 3.3
- LVC MOS 2.5
- LVC MOS 1.8
- 3.3V PCI Compatible

All of the I/Os and dedicated inputs have the capability to provide a bus-keeper latch, Pull-up Resistor or Pull-down Resistor. A fourth option is to provide none of these. The selection is done on a global basis. The default in both hardware and software is such that when the device is erased or if the user does not specify, the input structure is configured to be a Pull-up Resistor.

Each ispMACH 4000 device I/O has an individually programmable output slew rate control bit. Each output can be individually configured for fast slew or slow slew. The typical edge rate difference between fast and slow slew setting is 20%. For high-speed designs with long, unterminated traces, the slow-slew rate will introduce fewer reflections, less noise and keep ground bounce to a minimum. For designs with short traces or well terminated lines, the fast slew rate can be used to achieve the highest speed.

Global OE Generation

Most ispMACH 4000 family devices have a 4-bit wide Global OE Bus, except the ispMACH 4032 device that has a 2-bit wide Global OE Bus. This bus is derived from a 4-bit internal global OE PT bus and two dual purpose I/O or GOE pins. Each signal that drives the bus can optionally be inverted.

Each GLB has a block-level OE PT that connects to all bits of the Global OE PT bus with four fuses. Hence, for a 256-macrocell device (with 16 blocks), each line of the bus is driven from 16 OE product terms. Figures 9 and 10 show a graphical representation of the global OE generation.

Figure 9. Global OE Generation for All Devices Except ispMACH 4032



IEEE 1532-Compliant In-System Programming

Programming devices in-system provides a number of significant benefits including: rapid prototyping, lower inventory levels, higher quality and the ability to make in-field modifications. All ispMACH 4000 devices provide In-System Programming (ISP™) capability through the Boundary Scan Test Access Port. This capability has been implemented in a manner that ensures that the port remains compliant to the IEEE 1149.1 standard. By using IEEE 1149.1 as the communication interface through which ISP is achieved, users get the benefit of a standard, well-defined interface. All ispMACH 4000 devices are also compliant with the IEEE 1532 standard.

The ispMACH 4000 devices can be programmed across the commercial temperature and voltage range. The PC-based Lattice software facilitates in-system programming of ispMACH 4000 devices. The software takes the JEDEC file output produced by the design implementation software, along with information about the scan chain, and creates a set of vectors used to drive the scan chain. The software can use these vectors to drive a scan chain via the parallel port of a PC. Alternatively, the software can output files in formats understood by common automated test equipment. This equipment can then be used to program ispMACH 4000 devices during the testing of a circuit board.

User Electronic Signature

The User Electronic Signature (UES) allows the designer to include identification bits or serial numbers inside the device, stored in E²CMOS memory. The ispMACH 4000 device contains 32 UES bits that can be configured by the user to store unique data such as ID codes, revision numbers or inventory control codes.

Security Bit

A programmable security bit is provided on the ispMACH 4000 devices as a deterrent to unauthorized copying of the array configuration patterns. Once programmed, this bit defeats readback of the programmed pattern by a device programmer, securing proprietary designs from competitors. Programming and verification are also defeated by the security bit. The bit can only be reset by erasing the entire device.

Hot Socketing

The ispMACH 4000 devices are well-suited for applications that require hot socketing capability. Hot socketing a device requires that the device, during power-up and down, can tolerate active signals on the I/Os and inputs without being damaged. Additionally, it requires that the effects of I/O pin loading be minimal on active signals. The ispMACH 4000 devices provide this capability for input voltages in the range 0V to 3.0V.

Density Migration

The ispMACH 4000 family has been designed to ensure that different density devices in the same package have the same pin-out. Furthermore, the architecture ensures a high success rate when performing design migration from lower density parts to higher density parts. In many cases, it is possible to shift a lower utilization design targeted for a high density device to a lower density device. However, the exact details of the final resource utilization will impact the likely success in each case.

I/O Recommended Operating Conditions

Standard	V_{CCO} (V) ¹	
	Min.	Max.
LVTTTL	3.0	3.6
LVC MOS 3.3	3.0	3.6
Extended LVC MOS 3.3 ²	2.7	3.6
LVC MOS 2.5	2.3	2.7
LVC MOS 1.8	1.65	1.95
PCI 3.3	3.0	3.6

1. Typical values for V_{CCO} are the average of the min. and max. values.

2. ispMACH 4000Z only.

DC Electrical Characteristics

Over Recommended Operating Conditions

Symbol	Parameter	Condition	Min.	Typ.	Max.	Units
$I_{IL}, I_{IH}^{1,4}$	Input Leakage Current (ispMACH 4000Z)	$0 \leq V_{IN} < V_{CCO}$	—	0.5	1	μA
I_{IH}^1	Input High Leakage Current (ispMACH 4000Z)	$V_{CCO} < V_{IN} \leq 5.5V$	—	—	10	μA
I_{IL}, I_{IH}^1	Input Leakage Current (ispMACH 4000V/B/C)	$0 \leq V_{IN} \leq 3.6V, T_j = 105^\circ C$	—	—	10	μA
		$0 \leq V_{IN} \leq 3.6V, T_j = 130^\circ C$	—	—	15	μA
$I_{IH}^{1,2}$	Input High Leakage Current (ispMACH 4000V/B/C)	$3.6V < V_{IN} \leq 5.5V, T_j = 105^\circ C$ $3.0V \leq V_{CCO} \leq 3.6V$	—	—	20	μA
		$3.6V < V_{IN} \leq 5.5V, T_j = 130^\circ C$ $3.0V \leq V_{CCO} \leq 3.6V$	—	—	50	μA
I_{PU}	I/O Weak Pull-up Resistor Current (ispMACH 4000Z)	$0 \leq V_{IN} \leq 0.7V_{CCO}$	-30	—	-150	μA
	I/O Weak Pull-up Resistor Current (ispMACH 4000V/B/C)	$0 \leq V_{IN} \leq 0.7V_{CCO}$	-30	—	-200	μA
I_{PD}	I/O Weak Pull-down Resistor Current	$V_{IL} (MAX) \leq V_{IN} \leq V_{IH} (MIN)$	30	—	150	μA
I_{BHLS}	Bus Hold Low Sustaining Current	$V_{IN} = V_{IL} (MAX)$	30	—	—	μA
I_{BHHS}	Bus Hold High Sustaining Current	$V_{IN} = 0.7 V_{CCO}$	-30	—	—	μA
I_{BHLO}	Bus Hold Low Overdrive Current	$0V \leq V_{IN} \leq V_{BHT}$	—	—	150	μA
I_{BHHO}	Bus Hold High Overdrive Current	$V_{BHT} \leq V_{IN} \leq V_{CCO}$	—	—	-150	μA
V_{BHT}	Bus Hold Trip Points	—	$V_{CCO} * 0.35$	—	$V_{CCO} * 0.65$	V
C_1	I/O Capacitance ³	$V_{CCO} = 3.3V, 2.5V, 1.8V$	—	8	—	pf
		$V_{CC} = 1.8V, V_{IO} = 0$ to $V_{IH} (MAX)$	—		—	
C_2	Clock Capacitance ³	$V_{CCO} = 3.3V, 2.5V, 1.8V$	—	6	—	pf
		$V_{CC} = 1.8V, V_{IO} = 0$ to $V_{IH} (MAX)$	—		—	
C_3	Global Input Capacitance ³	$V_{CCO} = 3.3V, 2.5V, 1.8V$	—	6	—	pf
		$V_{CC} = 1.8V, V_{IO} = 0$ to $V_{IH} (MAX)$	—		—	

1. Input or I/O leakage current is measured with the pin configured as an input or as an I/O with the output driver tristated. It is not measured with the output driver active. Bus maintenance circuits are disabled.

2. 5V tolerant inputs and I/O should only be placed in banks where $3.0V \leq V_{CCO} \leq 3.6V$.

3. $T_A = 25^\circ C, f = 1.0MHz$

4. I_{IH} excursions of up to 1.5 μA maximum per pin above the spec limit may be observed for certain voltage conditions on no more than 10% of the device's I/O pins.

Supply Current, ispMACH 4000V/B/C (Cont.)

Over Recommended Operating Conditions

Symbol	Parameter	Condition	Min.	Typ.	Max.	Units
I _{CC} ⁴	Standby Power Supply Current	V _{CC} = 3.3V	—	13	—	mA
		V _{CC} = 2.5V	—	13	—	mA
		V _{CC} = 1.8V	—	3	—	mA

1. T_A = 25°C, frequency = 1.0 MHz.
2. Device configured with 16-bit counters.
3. I_{CC} varies with specific device configuration and operating frequency.
4. T_A = 25°C

Supply Current, ispMACH 4000Z

Over Recommended Operating Conditions

Symbol	Parameter	Condition	Min.	Typ.	Max.	Units
ispMACH 4032ZC						
ICC ^{1,2,3,5}	Operating Power Supply Current	V _{CC} = 1.8V, T _A = 25°C	—	50	—	μA
		V _{CC} = 1.9V, T _A = 70°C	—	58	—	μA
		V _{CC} = 1.9V, T _A = 85°C	—	60	—	μA
		V _{CC} = 1.9V, T _A = 125°C	—	70	—	μA
ICC ^{4,5}	Standby Power Supply Current	V _{CC} = 1.8V, T _A = 25°C	—	10	—	μA
		V _{CC} = 1.9V, T _A = 70°C	—	13	20	μA
		V _{CC} = 1.9V, T _A = 85°C	—	15	25	μA
		V _{CC} = 1.9V, T _A = 125°C	—	22	—	μA
ispMACH 4064ZC						
ICC ^{1,2,3,5}	Operating Power Supply Current	V _{CC} = 1.8V, T _A = 25°C	—	80	—	μA
		V _{CC} = 1.9V, T _A = 70°C	—	89	—	μA
		V _{CC} = 1.9V, T _A = 85°C	—	92	—	μA
		V _{CC} = 1.9V, T _A = 125°C	—	109	—	μA
ICC ^{4,5}	Standby Power Supply Current	V _{CC} = 1.8V, T _A = 25°C	—	11	—	μA
		V _{CC} = 1.9V, T _A = 70°C	—	15	25	μA
		V _{CC} = 1.9V, T _A = 85°C	—	18	35	μA
		V _{CC} = 1.9V, T _A = 125°C	—	37	—	μA
ispMACH 4128ZC						
ICC ^{1,2,3,5}	Operating Power Supply Current	V _{CC} = 1.8V, T _A = 25°C	—	168	—	μA
		V _{CC} = 1.9V, T _A = 70°C	—	190	—	μA
		V _{CC} = 1.9V, T _A = 85°C	—	195	—	μA
		V _{CC} = 1.9V, T _A = 125°C	—	212	—	μA
ICC ^{4,5}	Standby Power Supply Current	V _{CC} = 1.8V, T _A = 25°C	—	12	—	μA
		V _{CC} = 1.9V, T _A = 70°C	—	16	35	μA
		V _{CC} = 1.9V, T _A = 85°C	—	19	50	μA
		V _{CC} = 1.9V, T _A = 125°C	—	42	—	μA

I/O DC Electrical Characteristics

Over Recommended Operating Conditions

Standard	V_{IL}		V_{IH}		V_{OL} Max (V)	V_{OH} Min (V)	I_{OL}^1 (mA)	I_{OH}^1 (mA)
	Min (V)	Max (V)	Min (V)	Max (V)				
LVTTTL	-0.3	0.80	2.0	5.5	0.40	$V_{CCO} - 0.40$	8.0	-4.0
					0.20	$V_{CCO} - 0.20$	0.1	-0.1
LVCMOS 3.3	-0.3	0.80	2.0	5.5	0.40	$V_{CCO} - 0.40$	8.0	-4.0
					0.20	$V_{CCO} - 0.20$	0.1	-0.1
LVCMOS 2.5	-0.3	0.70	1.70	3.6	0.40	$V_{CCO} - 0.40$	8.0	-4.0
					0.20	$V_{CCO} - 0.20$	0.1	-0.1
LVCMOS 1.8 (4000V/B)	-0.3	0.63	1.17	3.6	0.40	$V_{CCO} - 0.45$	2.0	-2.0
					0.20	$V_{CCO} - 0.20$	0.1	-0.1
LVCMOS 1.8 (4000C/Z)	-0.3	$0.35 * V_{CC}$	$0.65 * V_{CC}$	3.6	0.40	$V_{CCO} - 0.45$	2.0	-2.0
					0.20	$V_{CCO} - 0.20$	0.1	-0.1
PCI 3.3 (4000V/B)	-0.3	1.08	1.5	5.5	$0.1 V_{CCO}$	$0.9 V_{CCO}$	1.5	-0.5
PCI 3.3 (4000C/Z)	-0.3	$0.3 * 3.3 * (V_{CC} / 1.8)$	$0.5 * 3.3 * (V_{CC} / 1.8)$	5.5	$0.1 V_{CCO}$	$0.9 V_{CCO}$	1.5	-0.5

1. The average DC current drawn by I/Os between adjacent bank GND connections, or between the last GND in an I/O bank and the end of the I/O bank, as shown in the logic signals connection table, shall not exceed $n * 8mA$. Where n is the number of I/Os between bank GND connections or between the last GND in a bank and the end of a bank.

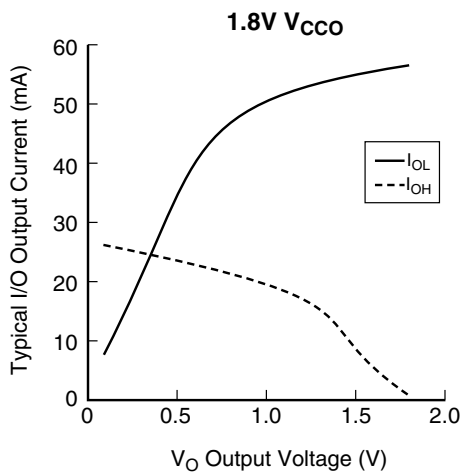
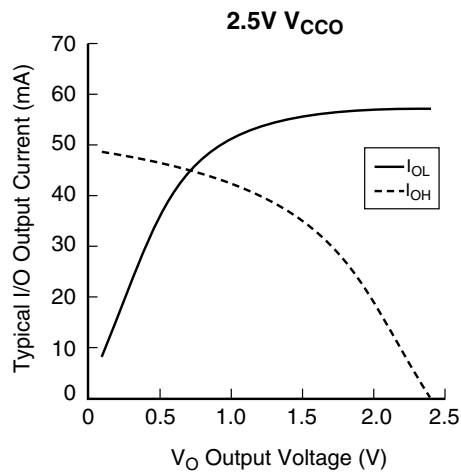
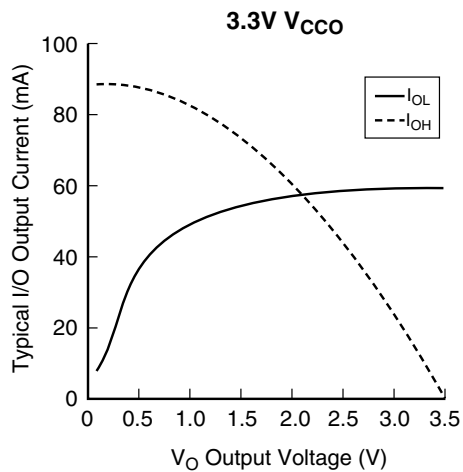

ispMACH 4000V/B/C External Switching Characteristics

Over Recommended Operating Conditions

Parameter	Description ^{1, 2, 3}	-25		-27		-3		-35		Units
		Min.	Max.	Min.	Max.	Min.	Max.	Min.	Max.	
t _{PD}	5-PT bypass combinatorial propagation delay	—	2.5	—	2.7	—	3.0	—	3.5	ns
t _{PD_MC}	20-PT combinatorial propagation delay through macrocell	—	3.2	—	3.5	—	3.8	—	4.2	ns
t _S	GLB register setup time before clock	1.8	—	1.8	—	2.0	—	2.0	—	ns
t _{ST}	GLB register setup time before clock with T-type register	2.0	—	2.0	—	2.2	—	2.2	—	ns
t _{SIR}	GLB register setup time before clock, input register path	0.7	—	1.0	—	1.0	—	1.0	—	ns
t _{SIRZ}	GLB register setup time before clock with zero hold	1.7	—	2.0	—	2.0	—	2.0	—	ns
t _H	GLB register hold time after clock	0.0	—	0.0	—	0.0	—	0.0	—	ns
t _{HT}	GLB register hold time after clock with T-type register	0.0	—	0.0	—	0.0	—	0.0	—	ns
t _{HIR}	GLB register hold time after clock, input register path	0.9	—	1.0	—	1.0	—	1.0	—	ns
t _{HIRZ}	GLB register hold time after clock, input register path with zero hold	0.0	—	0.0	—	0.0	—	0.0	—	ns
t _{CO}	GLB register clock-to-output delay	—	2.2	—	2.7	—	2.7	—	2.7	ns
t _R	External reset pin to output delay	—	3.5	—	4.0	—	4.4	—	4.5	ns
t _{RW}	External reset pulse duration	1.5	—	1.5	—	1.5	—	1.5	-	ns
t _{P_{TOE/DIS}}	Input to output local product term output enable/disable	—	4.0	—	4.5	—	5.0	—	5.5	ns
t _{G_{P_{TOE/DIS}}}	Input to output global product term output enable/disable	—	5.0	—	6.5	—	8.0	—	8.0	ns
t _{G_{OE/DIS}}	Global OE input to output enable/disable	—	3.0	—	3.5	—	4.0	—	4.5	ns
t _{CW}	Global clock width, high or low	1.1	—	1.3	—	1.3	—	1.3	—	ns
t _{GW}	Global gate width low (for low transparent) or high (for high transparent)	1.1	—	1.3	—	1.3	—	1.3	—	ns
t _{WIR}	Input register clock width, high or low	1.1	—	1.3	—	1.3	—	1.3	—	ns
f _{MAX} ⁴	Clock frequency with internal feedback	—	400	—	333	—	322	—	322	MHz
f _{MAX} (Ext.)	Clock frequency with external feedback, [1/ (t _S + t _{CO})]	—	250	—	222	—	212	—	212	MHz

1. Timing numbers are based on default LVCMOS 1.8 I/O buffers. Use timing adjusters provided to calculate other standards.

Timing v.3.2

2. Measured using standard switching circuit, assuming GRP loading of 1 and 1 output switching.

3. Pulse widths and clock widths less than minimum will cause unknown behavior.

4. Standard 16-bit counter using GRP feedback.

ispMACH 4000V/B/C External Switching Characteristics (Cont.)

Over Recommended Operating Conditions

Parameter	Description ^{1, 2, 3}	-5		-75		-10		Units
		Min.	Max.	Min.	Max.	Min.	Max.	
t _{PD}	5-PT bypass combinatorial propagation delay	—	5.0	—	7.5	—	10.0	ns
t _{PD_MC}	20-PT combinatorial propagation delay through macrocell	—	5.5	—	8.0	—	10.5	ns
t _S	GLB register setup time before clock	3.0	—	4.5	—	5.5	—	ns
t _{ST}	GLB register setup time before clock with T-type register	3.2	—	4.7	—	5.5	—	ns
t _{SIR}	GLB register setup time before clock, input register path	1.2	—	1.7	—	1.7	—	ns
t _{SIRZ}	GLB register setup time before clock with zero hold	2.2	—	2.7	—	2.7	—	ns
t _H	GLB register hold time after clock	0.0	—	0.0	—	0.0	—	ns
t _{HT}	GLB register hold time after clock with T-type register	0.0	—	0.0	—	0.0	—	ns
t _{HIR}	GLB register hold time after clock, input register path	1.0	—	1.0	—	1.0	—	ns
t _{HIRZ}	GLB register hold time after clock, input register path with zero hold	0.0	—	0.0	—	0.0	—	ns
t _{CO}	GLB register clock-to-output delay	—	3.4	—	4.5	—	6.0	ns
t _R	External reset pin to output delay	—	6.3	—	9.0	—	10.5	ns
t _{RW}	External reset pulse duration	2.0	—	4.0	—	4.0	—	ns
t _{P_{TOE/DIS}}	Input to output local product term output enable/disable	—	7.0	—	9.0	—	10.5	ns
t _{G_{P_{TOE/DIS}}}	Input to output global product term output enable/disable	—	9.0	—	10.3	—	12.0	ns
t _{GOE/DIS}	Global OE input to output enable/disable	—	5.0	—	7.0	—	8.0	ns
t _{CW}	Global clock width, high or low	2.2	—	2.8	—	4.0	—	ns
t _{GW}	Global gate width low (for low transparent) or high (for high transparent)	2.2	—	2.8	—	4.0	—	ns
t _{WIR}	Input register clock width, high or low	2.2	—	2.8	—	4.0	—	ns
f _{MAX} ⁴	Clock frequency with internal feedback	—	227	—	168	—	125	MHz
f _{MAX} (Ext.)	Clock frequency with external feedback, [1/ (t _S + t _{CO})]	—	156	—	111	—	86	MHz

1. Timing numbers are based on default LVCMOS 1.8 I/O buffers. Use timing adjusters provided to calculate other standards.

Timing v.3.2

2. Measured using standard switching circuit, assuming GRP loading of 1 and 1 output switching.

3. Pulse widths and clock widths less than minimum will cause unknown behavior.

4. Standard 16-bit counter using GRP feedback.

ispMACH 4000V/B/C Timing Adders¹ (Cont.)

Adder Type	Base Parameter	Description	-5		-75		-10		Units
			Min.	Max.	Min.	Max.	Min.	Max.	
Optional Delay Adders									
t_{INDIO}	t_{INREG}	Input register delay	—	1.00	—	1.00	—	1.00	ns
t_{EXP}	t_{MCELL}	Product term expander delay	—	0.33	—	0.33	—	0.33	ns
t_{ORP}	—	Output routing pool delay	—	0.05	—	0.05	—	0.05	ns
t_{BLA}	t_{ROUTE}	Additional block loading adder	—	0.05	—	0.05	—	0.05	ns
t_{IOI} Input Adjusters									
LVTTTL_in	$t_{IN}, t_{GCLK_IN}, t_{GOE}$	Using LVTTTL standard	—	0.60	—	0.60	—	0.60	ns
LVC MOS33_in	$t_{IN}, t_{GCLK_IN}, t_{GOE}$	Using LVC MOS 3.3 standard	—	0.60	—	0.60	—	0.60	ns
LVC MOS25_in	$t_{IN}, t_{GCLK_IN}, t_{GOE}$	Using LVC MOS 2.5 standard	—	0.60	—	0.60	—	0.60	ns
LVC MOS18_in	$t_{IN}, t_{GCLK_IN}, t_{GOE}$	Using LVC MOS 1.8 standard	—	0.00	—	0.00	—	0.00	ns
PCI_in	$t_{IN}, t_{GCLK_IN}, t_{GOE}$	Using PCI compatible input	—	0.60	—	0.60	—	0.60	ns
t_{IOO} Output Adjusters									
LVTTTL_out	t_{BUF}, t_{EN}, t_{DIS}	Output configured as TTL buffer	—	0.20	—	0.20	—	0.20	ns
LVC MOS33_out	t_{BUF}, t_{EN}, t_{DIS}	Output configured as 3.3V buffer	—	0.20	—	0.20	—	0.20	ns
LVC MOS25_out	t_{BUF}, t_{EN}, t_{DIS}	Output configured as 2.5V buffer	—	0.10	—	0.10	—	0.10	ns
LVC MOS18_out	t_{BUF}, t_{EN}, t_{DIS}	Output configured as 1.8V buffer	—	0.00	—	0.00	—	0.00	ns
PCI_out	t_{BUF}, t_{EN}, t_{DIS}	Output configured as PCI compatible buffer	—	0.20	—	0.20	—	0.20	ns
Slow Slew	t_{BUF}, t_{EN}	Output configured for slow slew rate	—	1.00	—	1.00	—	1.00	ns

Note: Open drain timing is the same as corresponding LVC MOS timing.

Timing v.3.2

1. Refer to TN1004, [ispMACH 4000 Timing Model Design and Usage Guidelines](#) for information regarding use of these adders.

**ispMACH 4032V/B/C and 4064V/B/C Logic Signal Connections:
44-Pin TQFP (Cont.)**

Pin Number	Bank Number	ispMACH 4032V/B/C		ispMACH 4064V/B/C	
		GLB/MC/Pad	ORP	GLB/MC/Pad	ORP
42	0	A2	A ²	A4	A ²
43	0	A3	A ³	A6	A ³
44	0	A4	A ⁴	A8	A ⁴

**ispMACH 4032V/B/C/Z and 4064V/B/C/Z Logic Signal Connections:
48-Pin TQFP**

Pin Number	Bank Number	ispMACH 4032V/B/C/Z		ispMACH 4064V/B/C		ispMACH 4064Z	
		GLB/MC/Pad	ORP	GLB/MC/Pad	ORP	GLB/MC/Pad	ORP
1	-	TDI	-	TDI	-	TDI	-
2	0	A5	A ⁵	A10	A ⁵	A8	A ⁵
3	0	A6	A ⁶	A12	A ⁶	A10	A ⁶
4	0	A7	A ⁷	A14	A ⁷	A11	A ⁷
5	0	GND (Bank 0)	-	GND (Bank 0)	-	GND (Bank 0)	-
6	0	VCCO (Bank 0)	-	VCCO (Bank 0)	-	VCCO (Bank 0)	-
7	0	A8	A ⁸	B0	B ⁰	B15	B ⁷
8	0	A9	A ⁹	B2	B ¹	B12	B ⁶
9	0	A10	A ¹⁰	B4	B ²	B10	B ⁵
10	0	A11	A ¹¹	B6	B ³	B8	B ⁴
11	-	TCK	-	TCK	-	TCK	-
12	-	VCC	-	VCC	-	VCC	-
13	-	GND	-	GND	-	GND	-
14	0	A12	A ¹²	B8	B ⁴	B6	B ³
15	0	A13	A ¹³	B10	B ⁵	B4	B ²
16	0	A14	A ¹⁴	B12	B ⁶	B2	B ¹
17	0	A15	A ¹⁵	B14	B ⁷	B0	B ⁰
18	0	CLK1/I	-	CLK1/I	-	CLK1/I	-
19	1	CLK2/I	-	CLK2/I	-	CLK2/I	-
20	1	B0	B ⁰	C0	C ⁰	C0	C ⁰
21	1	B1	B ¹	C2	C ¹	C1	C ¹
22	1	B2	B ²	C4	C ²	C2	C ²
23	1	B3	B ³	C6	C ³	C4	C ³
24	1	B4	B ⁴	C8	C ⁴	C6	C ⁴
25	-	TMS	-	TMS	-	TMS	-
26	1	B5	B ⁵	C10	C ⁵	C8	C ⁵
27	1	B6	B ⁶	C12	C ⁶	C10	C ⁶
28	1	B7	B ⁷	C14	C ⁷	C11	C ⁷
29	1	GND (Bank 1)	-	GND (Bank 1)	-	GND (Bank 1)	-
30	1	VCCO (Bank 1)	-	VCCO (Bank 1)	-	VCCO (Bank 1)	-
31	1	B8	B ⁸	D0	D ⁰	D15	D ⁷
32	1	B9	B ⁹	D2	D ¹	D12	D ⁶

**ispMACH 4064V/B/C/Z, 4128V/B/C/Z, 4256V/B/C/Z Logic Signal Connections:
100-Pin TQFP**

Pin Number	Bank Number	ispMACH 4064V/B/C/Z		ispMACH 4128V/B/C/Z		ispMACH 4256V/B/C/Z	
		GLB/MC/Pad	ORP	GLB/MC/Pad	ORP	GLB/MC/Pad	ORP
1	-	GND	-	GND	-	GND	-
2	-	TDI	-	TDI	-	TDI	-
3	0	A8	A^8	B0	B^0	C12	C^3
4	0	A9	A^9	B2	B^1	C10	C^2
5	0	A10	A^10	B4	B^2	C6	C^1
6	0	A11	A^11	B6	B^3	C2	C^0
7	0	GND (Bank 0)	-	GND (Bank 0)	-	GND (Bank 0)	-
8	0	A12	A^12	B8	B^4	D12	D^3
9	0	A13	A^13	B10	B^5	D10	D^2
10	0	A14	A^14	B12	B^6	D6	D^1
11	0	A15	A^15	B13	B^7	D4	D^0
12*	0	I	-	I	-	I	-
13	0	VCCO (Bank 0)	-	VCCO (Bank 0)	-	VCCO (Bank 0)	-
14	0	B15	B^15	C14	C^7	E4	E^0
15	0	B14	B^14	C12	C^6	E6	E^1
16	0	B13	B^13	C10	C^5	E10	E^2
17	0	B12	B^12	C8	C^4	E12	E^3
18	0	GND (Bank 0)	-	GND (Bank 0)	-	GND (Bank 0)	-
19	0	B11	B^11	C6	C^3	F2	F^0
20	0	B10	B^10	C5	C^2	F6	F^1
21	0	B9	B^9	C4	C^1	F10	F^2
22	0	B8	B^8	C2	C^0	F12	F^3
23*	0	I	-	I	-	I	-
24	-	TCK	-	TCK	-	TCK	-
25	-	VCC	-	VCC	-	VCC	-
26	-	GND	-	GND	-	GND	-
27*	0	I	-	I	-	I	-
28	0	B7	B^7	D13	D^7	G12	G^3
29	0	B6	B^6	D12	D^6	G10	G^2
30	0	B5	B^5	D10	D^5	G6	G^1
31	0	B4	B^4	D8	D^4	G2	G^0
32	0	GND (Bank 0)	-	GND (Bank 0)	-	GND (Bank 0)	-
33	0	VCCO (Bank 0)	-	VCCO (Bank 0)	-	VCCO (Bank 0)	-
34	0	B3	B^3	D6	D^3	H12	H^3
35	0	B2	B^2	D4	D^2	H10	H^2
36	0	B1	B^1	D2	D^1	H6	H^1
37	0	B0	B^0	D0	D^0	H2	H^0
38	0	CLK1/I	-	CLK1/I	-	CLK1/I	-
39	1	CLK2/I	-	CLK2/I	-	CLK2/I	-
40	-	VCC	-	VCC	-	VCC	-
41	1	C0	C^0	E0	E^0	I2	I^0

**ispMACH 4256V/B/C/Z, 4384V/B/C, 4512V/B/C, Logic Signal Connections:
176-Pin TQFP (Cont.)**

Pin Number	Bank Number	ispMACH 4256V/B/C/Z		ispMACH 4384V/B/C		ispMACH 4512V/B/C	
		GLB/MC/Pad	ORP	GLB/MC/Pad	ORP	GLB/MC/Pad	ORP
19	0	D4	D ²	E4	E ²	G4	G ²
20	0	D2	D ¹	E2	E ¹	G2	G ¹
21	0	D0	D ⁰	E0	E ⁰	G0	G ⁰
22	0	VCCO (Bank 0)	-	VCCO (Bank 0)	-	VCCO (Bank 0)	-
23	0	E0	E ⁰	H0	H ⁰	J0	J ⁰
24	0	E2	E ¹	H2	H ¹	J2	J ¹
25	0	E4	E ²	H4	H ²	J4	J ²
26	0	E6	E ³	H6	H ³	J6	J ³
27	0	E8	E ⁴	H8	H ⁴	J8	J ⁴
28	0	E10	E ⁵	H10	H ⁵	J10	J ⁵
29	0	E12	E ⁶	H12	H ⁶	J12	J ⁶
30	0	E14	E ⁷	H14	H ⁷	J14	J ⁷
31	0	GND (Bank 0)	-	GND (Bank 0)	-	GND (Bank 0)	-
32	0	F0	F ⁰	J0	J ⁰	N0	N ⁰
33	0	F2	F ¹	J2	J ¹	N2	N ¹
34	0	F4	F ²	J4	J ²	N4	N ²
35	0	F6	F ³	J6	J ³	N6	N ³
36	0	F8	F ⁴	J8	J ⁴	N8	N ⁴
37	0	F10	F ⁵	J10	J ⁵	N10	N ⁵
38	0	F12	F ⁶	J12	J ⁶	N12	N ⁶
39	0	F14	F ⁷	J14	J ⁷	N14	N ⁷
40	0	VCCO (Bank 0)	-	VCCO (Bank 0)	-	VCCO (Bank 0)	-
41	-	TCK	-	TCK	-	TCK	-
42	-	VCC	-	VCC	-	VCC	-
43	-	NC	-	NC	-	NC	-
44	-	NC	-	NC	-	NC	-
45	-	NC	-	NC	-	NC	-
46	-	GND	-	GND (Bank 0)	-	GND	-
47	0	G14	G ⁷	K14	K ⁷	O14	O ⁷
48	0	G12	G ⁶	K12	K ⁶	O12	O ⁶
49	0	G10	G ⁵	K10	K ⁵	O10	O ⁵
50	0	G8	G ⁴	K8	K ⁴	O8	O ⁴
51	0	G6	G ³	K6	K ³	O6	O ³
52	0	G4	G ²	K4	K ²	O4	O ²
53	0	G2	G ¹	K2	K ¹	O2	O ¹
54	0	G0	G ⁰	K0	K ⁰	O0	O ⁰
55	0	GND (Bank 0)	-	GND (Bank 0)	-	GND (Bank 0)	-
56	0	VCCO (Bank 0)	-	VCCO (Bank 0)	-	VCCO (Bank 0)	-
57	0	H14	H ⁷	L14	L ⁷	P14	P ⁷
58	0	H12	H ⁶	L12	L ⁶	P12	P ⁶
59	0	H10	H ⁵	L10	L ⁵	P10	P ⁵

**ispMACH 4256V/B/C/Z, 4384V/B/C, 4512V/B/C, Logic Signal Connections:
176-Pin TQFP (Cont.)**

Pin Number	Bank Number	ispMACH 4256V/B/C/Z		ispMACH 4384V/B/C		ispMACH 4512V/B/C	
		GLB/MC/Pad	ORP	GLB/MC/Pad	ORP	GLB/MC/Pad	ORP
101	1	GND (Bank 1)	-	GND (Bank 1)	-	GND (Bank 1)	-
102	1	L14	L^7	AX14	AX^7	GX14	GX^7
103	1	L12	L^6	AX12	AX^6	GX12	GX^6
104	1	L10	L^5	AX10	AX^5	GX10	GX^5
105	1	L8	L^4	AX8	AX^4	GX8	GX^4
106	1	L6	L^3	AX6	AX^3	GX6	GX^3
107	1	L4	L^2	AX4	AX^2	GX4	GX^2
108	1	L2	L^1	AX2	AX^1	GX2	GX^1
109	1	L0	L^0	AX0	AX^0	GX0	GX^0
110	1	VCCO (Bank 1)	-	VCCO (Bank 1)	-	VCCO (Bank 1)	-
111	1	M0	M^0	DX0	DX^0	JX0	JX^0
112	1	M2	M^1	DX2	DX^1	JX2	JX^1
113	1	M4	M^2	DX4	DX^2	JX4	JX^2
114	1	M6	M^3	DX6	DX^3	JX6	JX^3
115	1	M8	M^4	DX8	DX^4	JX8	JX^4
116	1	M10	M^5	DX10	DX^5	JX10	JX^5
117	1	M12	M^6	DX12	DX^6	JX12	JX^6
118	1	M14	M^7	DX14	DX^7	JX14	JX^7
119	1	GND (Bank 1)	-	GND (Bank 1)	-	GND (Bank 1)	-
120	1	N0	N^0	FX0	FX^0	NX0	NX^0
121	1	N2	N^1	FX2	FX^1	NX2	NX^1
122	1	N4	N^2	FX4	FX^2	NX4	NX^2
123	1	N6	N^3	FX6	FX^3	NX6	NX^3
124	1	N8	N^4	FX8	FX^4	NX8	NX^4
125	1	N10	N^5	FX10	FX^5	NX10	NX^5
126	1	N12	N^6	FX12	FX^6	NX12	NX^6
127	1	N14	N^7	FX14	FX^7	NX14	NX^7
128	1	VCCO (Bank 1)	-	VCCO (Bank 1)	-	VCCO (Bank 1)	-
129	-	TDO	-	TDO	-	TDO	-
130	-	VCC	-	VCC	-	VCC	-
131	-	NC	-	NC	-	NC	-
132	-	NC	-	NC	-	NC	-
133	-	NC	-	NC	-	NC	-
134	-	GND	-	GND	-	GND	-
135	1	O14	O^7	GX14	GX^7	OX14	OX^7
136	1	O12	O^6	GX12	GX^6	OX12	OX^6
137	1	O10	O^5	GX10	GX^5	OX10	OX^5
138	1	O8	O^4	GX8	GX^4	OX8	OX^4
139	1	O6	O^3	GX6	GX^3	OX6	OX^3
140	1	O4	O^2	GX4	GX^2	OX4	OX^2
141	1	O2	O^1	GX2	GX^1	OX2	OX^1

**ispMACH 4256V/B/C, 4384V/B/C, 4512V/B/C Logic Signal Connections:
256-Ball ftBGA/fpBGA**

Ball Number	I/O Bank	ispMACH 4256V/B/C 128-I/O		ispMACH 4256V/B/C 160-I/O		ispMACH 4384V/B/C		ispMACH 4512V/B/C	
		GLB/MC/Pad	ORP	GLB/MC/Pad	ORP	GLB/MC/Pad	ORP	GLB/MC/Pad	ORP
-	-	-	-	-	-	VCC	-	VCC	-
-	-	GND	-	GND	-	GND	-	GND	-
C3	-	TDI	-	TDI	-	TDI	-	TDI	-
-	0	VCCO (Bank 0)	-	VCCO (Bank 0)	-	VCCO (Bank 0)	-	VCCO (Bank 0)	-
B1	0	C14	C^7	C14	C^9	C14	C^7	C14	C^7
F5	0	C12	C^6	C12	C^8	C12	C^6	C12	C^6
D3	0	C10	C^5	C10	C^7	C10	C^5	C10	C^5
C1	0	C8	C^4	C9	C^6	C8	C^4	C8	C^4
C2	0	C6	C^3	C8	C^5	C6	C^3	C6	C^3
E3	0	C4	C^2	C6	C^4	C4	C^2	C4	C^2
D2	0	C2	C^1	C4	C^3	C2	C^1	C2	C^1
F6	0	C0	C^0	C2	C^2	C0	C^0	C0	C^0
D1	0	NC	-	C1	C^1	F6	F^3	H0	H^0
E2	0	NC	-	C0	C^0	F4	F^2	H4	H^1
E4	0	NC	-	NC	-	D6	D^3	F4	F^2
G5	0	NC	-	NC	-	D4	D^2	F6	F^3
E1	0	NC	-	NC	-	NC	-	F8	F^4
-	0	-	-	VCCO (Bank 0)	-	VCCO (Bank 0)	-	VCCO (Bank 0)	-
-	0	GND (Bank 0)	-	GND (Bank 0)	-	GND (Bank 0)	-	GND (Bank 0)	-
F2	0	NC	-	NC	-	NC	-	F10	F^5
F1	0	NC	-	NC	-	D2	D^1	F12	F^6
G1	0	NC	-	NC	-	D0	D^0	F14	F^7
G6	0	NC	-	D14	D^9	F2	F^1	H8	H^2
G4	0	NC	-	D12	D^8	F0	F^0	H12	H^3
H6	0	D14	D^7	D10	D^7	E14	E^7	G14	G^7
G3	0	D12	D^6	D9	D^6	E12	E^6	G12	G^6
H5	0	D10	D^5	D8	D^5	E10	E^5	G10	G^5
G2	0	D8	D^4	D6	D^4	E8	E^4	G8	G^4
H1	0	D6	D^3	D4	D^3	E6	E^3	G6	G^3
H2	0	D4	D^2	D2	D^2	E4	E^2	G4	G^2
H3	0	D2	D^1	D1	D^1	E2	E^1	G2	G^1
H4	0	D0	D^0	D0	D^0	E0	E^0	G0	G^0
-	0	VCCO (Bank 0)	-	VCCO (Bank 0)	-	VCCO (Bank 0)	-	VCCO (Bank 0)	-
-	0	-	-	GND (Bank 0)	-	GND (Bank 0)	-	GND (Bank 0)	-
J4	0	E0	E^0	E0	E^0	H0	H^0	J0	J^0
J3	0	E2	E^1	E1	E^1	H2	H^1	J2	J^1
J2	0	E4	E^2	E2	E^2	H4	H^2	J4	J^2
J1	0	E6	E^3	E4	E^3	H6	H^3	J6	J^3
K1	0	E8	E^4	E6	E^4	H8	H^4	J8	J^4
J5	0	E10	E^5	E8	E^5	H10	H^5	J10	J^5
K2	0	E12	E^6	E9	E^6	H12	H^6	J12	J^6

**ispMACH 4256V/B/C, 4384V/B/C, 4512V/B/C Logic Signal Connections:
256-Ball ftBGA/fpBGA (Cont.)**

Ball Number	I/O Bank	ispMACH 4256V/B/C 128-I/O		ispMACH 4256V/B/C 160-I/O		ispMACH 4384V/B/C		ispMACH 4512V/B/C	
		GLB/MC/Pad	ORP	GLB/MC/Pad	ORP	GLB/MC/Pad	ORP	GLB/MC/Pad	ORP
C12	1	O0	O^0	O2	O^2	GX0	GX^0	OX0	OX^0
E10	1	NC	-	O1	O^1	CX8	CX^4	MX0	MX^0
A13	1	NC	-	O0	O^0	CX10	CX^5	MX4	MX^1
D12	1	NC	-	NC	-	NC	-	LX0	LX^0
-	1	GND (Bank 1)	-	GND (Bank 1)	-	GND (Bank 1)	-	GND (Bank 1)	-
-	1	VCCO (Bank 1)	-	VCCO (Bank 1)	-	VCCO (Bank 1)	-	VCCO (Bank 1)	-
B12	1	NC	-	NC	-	NC	-	LX4	LX^1
A12	1	NC	-	NC	-	EX2	EX^1	LX8	LX^2
B11	1	NC	-	NC	-	EX0	EX^0	LX12	LX^3
A11	1	NC	-	P14	P^9	CX12	CX^6	MX8	MX^2
D10	1	NC	-	P12	P^8	CX14	CX^7	MX12	MX^3
C10	1	P14	P^7	P10	P^7	HX14	HX^7	PX14	PX^7
B10	1	P12	P^6	P9	P6	HX12	HX^6	PX12	PX^6
A10	1	P10	P^5	P8	P^5	HX10	HX^5	PX10	PX^5
A9	1	P8	P^4	P6	P^4	HX8	HX^4	PX8	PX^4
F9	1	P6	P^3	P4	P^3	HX6	HX^3	PX6	PX^3
B9	1	P4	P^2	P2	P^2	HX4	HX^2	PX4	PX^2
E9	1	P2/GOE1	P^1	P1/GOE1	P^1	HX2/GOE1	HX^1	PX2/GOE1	PX^1
C9	1	P0	P^0	P0	P^0	HX0	HX^0	PX0	PX^0
-	-	GND	-	GND	-	GND	-	GND	-
D9	1	CLK3/I	-	CLK3/I	-	CLK3/I	-	CLK3/I	-
-	0	GND (Bank 0)	-	GND (Bank 0)	-	GND (Bank 0)	-	GND (Bank 0)	-
B8	0	CLK0/I	-	CLK0/I	-	CLK0/I	-	CLK0/I	-
-	-	VCC	-	VCC	-	VCC	-	VCC	-
D8	0	A0	A^0	A0	A^0	A0	A^0	A0	A^0
C8	0	A2/GOE0	A^1	A1/GOE0	A^1	A2/GOE0	A^1	A2/GOE0	A^1
A8	0	A4	A^2	A2	A^2	A4	A^2	A4	A^2
A7	0	A6	A^3	A4	A^3	A6	A^3	A6	A^3
B7	0	A8	A^4	A6	A^4	A8	A^4	A8	A^4
E8	0	A10	A^5	A8	A^5	A10	A^5	A10	A^5
D7	0	A12	A^6	A9	A^6	A12	A^6	A12	A^6
F8	0	A14	A^7	A10	A^7	A14	A^7	A14	A^7
C7	0	NC	-	A12	A^8	F14	F^7	D0	D^0
A6	0	NC	-	A14	A^9	F12	F^6	D4	D^1
B6	0	NC	-	NC	-	D14	D^7	E0	E^0
A5	0	NC	-	NC	-	D12	D^6	E4	E^1
B5	0	NC	-	NC	-	NC	-	E8	E^2
-	0	VCCO (Bank 0)	-	VCCO (Bank 0)	-	VCCO (Bank 0)	-	VCCO (Bank 0)	-
-	0	GND (Bank 0)	-	GND (Bank 0)	-	GND (Bank 0)	-	GND (Bank 0)	-
D5	0	NC	-	NC	-	NC	-	E12	E^3
A4	0	NC	-	B0	B^0	F10	F^5	D8	D^2

ispMACH 4000V (3.3V) Commercial Devices (Cont.)

Device	Part Number	Macrocells	Voltage	t _{PD}	Package	Pin/Ball Count	I/O	Grade
LC4512V	LC4512V-35FT256C	512	3.3	3.5	ftBGA	256	208	C
	LC4512V-5FT256C	512	3.3	5	ftBGA	256	208	C
	LC4512V-75FT256C	512	3.3	7.5	ftBGA	256	208	C
	LC4512V-35F256C ¹	512	3.3	3.5	fpBGA	256	208	C
	LC4512V-5F256C ¹	512	3.3	5	fpBGA	256	208	C
	LC4512V-75F256C ¹	512	3.3	7.5	fpBGA	256	208	C
	LC4512V-35T176C	512	3.3	3.5	TQFP	176	128	C
	LC4512V-5T176C	512	3.3	5	TQFP	176	128	C
	LC4512V-75T176C	512	3.3	7.5	TQFP	176	128	C

1. Use ftBGA package. fpBGA package devices have been discontinued via PCN#14A-07.

ispMACH 4000V (3.3V) Industrial Devices

Family	Part Number	Macrocells	Voltage	t _{PD}	Package	Pin/Ball Count	I/O	Grade
LC4032V	LC4032V-5T48I	32	3.3	5	TQFP	48	32	I
	LC4032V-75T48I	32	3.3	7.5	TQFP	48	32	I
	LC4032V-10T48I	32	3.3	10	TQFP	48	32	I
	LC4032V-5T44I	32	3.3	5	TQFP	44	30	I
	LC4032V-75T44I	32	3.3	7.5	TQFP	44	30	I
	LC4032V-10T44I	32	3.3	10	TQFP	44	30	I
LC4064V	LC4064V-5T100I	64	3.3	5	TQFP	100	64	I
	LC4064V-75T100I	64	3.3	7.5	TQFP	100	64	I
	LC4064V-10T100I	64	3.3	10	TQFP	100	64	I
	LC4064V-5T48I	64	3.3	5	TQFP	48	32	I
	LC4064V-75T48I	64	3.3	7.5	TQFP	48	32	I
	LC4064V-10T48I	64	3.3	10	TQFP	48	32	I
	LC4064V-5T44I	64	3.3	5	TQFP	44	30	I
	LC4064V-75T44I	64	3.3	7.5	TQFP	44	30	I
	LC4064V-10T44I	64	3.3	10	TQFP	44	30	I
LC4128V	LC4128V-5T144I	128	3.3	5	TQFP	144	96	I
	LC4128V-75T144I	128	3.3	7.5	TQFP	144	96	I
	LC4128V-10T144I	128	3.3	10	TQFP	144	96	I
	LC4128V-5T128I	128	3.3	5	TQFP	128	92	I
	LC4128V-75T128I	128	3.3	7.5	TQFP	128	92	I
	LC4128V-10T128I	128	3.3	10	TQFP	128	92	I
	LC4128V-5T100I	128	3.3	5	TQFP	100	64	I
	LC4128V-75T100I	128	3.3	7.5	TQFP	100	64	I
	LC4128V-10T100I	128	3.3	10	TQFP	100	64	I

ispMACH 4000C (1.8V) Lead-Free Commercial Devices (Cont.)

Device	Part Number	Macrocells	Voltage	t _{PD}	Package	Pin/Ball Count	I/O	Grade
LC4064C	LC4064C-25TN100C	64	1.8	2.5	Lead-free TQFP	100	64	C
	LC4064C-5TN100C	64	1.8	5	Lead-free TQFP	100	64	C
	LC4064C-75TN100C	64	1.8	7.5	Lead-free TQFP	100	64	C
	LC4064C-25TN48C	64	1.8	2.5	Lead-free TQFP	48	32	C
	LC4064C-5TN48C	64	1.8	5	Lead-free TQFP	48	32	C
	LC4064C-75TN48C	64	1.8	7.5	Lead-free TQFP	48	32	C
	LC4064C-25TN44C	64	1.8	2.5	Lead-free TQFP	44	30	C
	LC4064C-5TN44C	64	1.8	5	Lead-free TQFP	44	30	C
LC4128C	LC4128C-27TN128C	128	1.8	2.7	Lead-free TQFP	128	92	C
	LC4128C-5TN128C	128	1.8	5	Lead-free TQFP	128	92	C
	LC4128C-75TN128C	128	1.8	7.5	Lead-free TQFP	128	92	C
	LC4128C-27TN100C	128	1.8	2.7	Lead-free TQFP	100	64	C
	LC4128C-5TN100C	128	1.8	5	Lead-free TQFP	100	64	C
	LC4128C-75TN100C	128	1.8	7.5	Lead-free TQFP	100	64	C
LC4256C	LC4256C-3FTN256AC	256	1.8	3	Lead-free ftBGA	256	128	C
	LC4256C-5FTN256AC	256	1.8	5	Lead-free ftBGA	256	128	C
	LC4256C-75FTN256AC	256	1.8	7.5	Lead-free ftBGA	256	128	C
	LC4256C-3FTN256BC	256	1.8	3	Lead-free ftBGA	256	160	C
	LC4256C-5FTN256BC	256	1.8	5	Lead-free ftBGA	256	160	C
	LC4256C-75FTN256BC	256	1.8	7.5	Lead-free ftBGA	256	160	C
	LC4256C-3FN256AC ¹	256	1.8	3	Lead-free fpBGA	256	128	C
	LC4256C-5FN256AC ¹	256	1.8	5	Lead-free fpBGA	256	128	C
	LC4256C-75FN256AC ¹	256	1.8	7.5	Lead-free fpBGA	256	128	C
	LC4256C-3FN256BC ¹	256	1.8	3	Lead-free fpBGA	256	160	C
	LC4256C-5FN256BC ¹	256	1.8	5	Lead-free fpBGA	256	160	C
	LC4256C-75FN256BC ¹	256	1.8	7.5	Lead-free fpBGA	256	160	C
	LC4256C-3TN176C	256	1.8	3	Lead-free TQFP	176	128	C
	LC4256C-5TN176C	256	1.8	5	Lead-free TQFP	176	128	C
	LC4256C-75TN176C	256	1.8	7.5	Lead-free TQFP	176	128	C
	LC4256C-3TN100C	256	1.8	3	Lead-free TQFP	100	64	C
LC4256C-5TN100C	256	1.8	5	Lead-free TQFP	100	64	C	
LC4256C-75TN100C	256	1.8	7.5	Lead-free TQFP	100	64	C	
LC4384C	LC4384C-35FTN256C	384	1.8	3.5	Lead-free ftBGA	256	192	C
	LC4384C-5FTN256C	384	1.8	5	Lead-free ftBGA	256	192	C
	LC4384C-75FTN256C	384	1.8	7.5	Lead-free ftBGA	256	192	C
	LC4384C-35FN256C ¹	384	1.8	3.5	Lead-free fpBGA	256	192	C
	LC4384C-5FN256C ¹	384	1.8	5	Lead-free fpBGA	256	192	C
	LC4384C-75FN256C ¹	384	1.8	7.5	Lead-free fpBGA	256	192	C
	LC4384C-35TN176C	384	1.8	3.5	Lead-free TQFP	176	128	C
	LC4384C-5TN176C	384	1.8	5	Lead-free TQFP	176	128	C
LC4384C-75TN176C	384	1.8	7.5	Lead-free TQFP	176	128	C	

ispMACH 4000V (3.3V) Lead-Free Industrial Devices

Device	Part Number	Macrocells	Voltage	t _{PD}	Package	Pin/Ball Count	I/O	Grade
LC4032V	LC4032V-5TN48I	32	3.3	5	Lead-free TQFP	48	32	I
	LC4032V-75TN48I	32	3.3	7.5	Lead-free TQFP	48	32	I
	LC4032V-10TN48I	32	3.3	10	Lead-free TQFP	48	32	I
	LC4032V-5TN44I	32	3.3	5	Lead-free TQFP	44	30	I
	LC4032V-75TN44I	32	3.3	7.5	Lead-free TQFP	44	30	I
	LC4032V-10TN44I	32	3.3	10	Lead-free TQFP	44	30	I
LC4064V	LC4064V-5TN100I	64	3.3	5	Lead-free TQFP	100	64	I
	LC4064V-75TN100I	64	3.3	7.5	Lead-free TQFP	100	64	I
	LC4064V-10TN100I	64	3.3	10	Lead-free TQFP	100	64	I
	LC4064V-5TN48I	64	3.3	5	Lead-free TQFP	48	32	I
	LC4064V-75TN48I	64	3.3	7.5	Lead-free TQFP	48	32	I
	LC4064V-10TN48I	64	3.3	10	Lead-free TQFP	48	32	I
	LC4064V-5TN44I	64	3.3	5	Lead-free TQFP	44	30	I
	LC4064V-75TN44I	64	3.3	7.5	Lead-free TQFP	44	30	I
LC4128V	LC4128V-5TN144I	128	3.3	5	Lead-free TQFP	144	96	I
	LC4128V-75TN144I	128	3.3	7.5	Lead-free TQFP	144	96	I
	LC4128V-10TN144I	128	3.3	10	Lead-free TQFP	144	96	I
	LC4128V-5TN128I	128	3.3	5	Lead-free TQFP	128	92	I
	LC4128V-75TN128I	128	3.3	7.5	Lead-free TQFP	128	92	I
	LC4128V-10TN128I	128	3.3	10	Lead-free TQFP	128	92	I
	LC4128V-5TN100I	128	3.3	5	Lead-free TQFP	100	64	I
	LC4128V-75TN100I	128	3.3	7.5	Lead-free TQFP	100	64	I
	LC4128V-10TN100I	128	3.3	10	Lead-free TQFP	100	64	I