

Welcome to [E-XFL.COM](https://www.e-xfl.com)

Understanding [Embedded - CPLDs \(Complex Programmable Logic Devices\)](#)

Embedded - CPLDs, or Complex Programmable Logic Devices, are highly versatile digital logic devices used in electronic systems. These programmable components are designed to perform complex logical operations and can be customized for specific applications. Unlike fixed-function ICs, CPLDs offer the flexibility to reprogram their configuration, making them an ideal choice for various embedded systems. They consist of a set of logic gates and programmable interconnects, allowing designers to implement complex logic circuits without needing custom hardware.

Applications of Embedded - CPLDs

Details

Product Status	Active
Programmable Type	In System Programmable
Delay Time tpd(1) Max	7.5 ns
Voltage Supply - Internal	1.7V ~ 1.9V
Number of Logic Elements/Blocks	4
Number of Macrocells	64
Number of Gates	-
Number of I/O	32
Operating Temperature	0°C ~ 90°C (Tj)
Mounting Type	Surface Mount
Package / Case	56-LFBGA, CSPBGA
Supplier Device Package	56-CSBGA (6x6)
Purchase URL	https://www.e-xfl.com/product-detail/lattice-semiconductor/lc4064zc-75mn56c

Figure 1. Functional Block Diagram

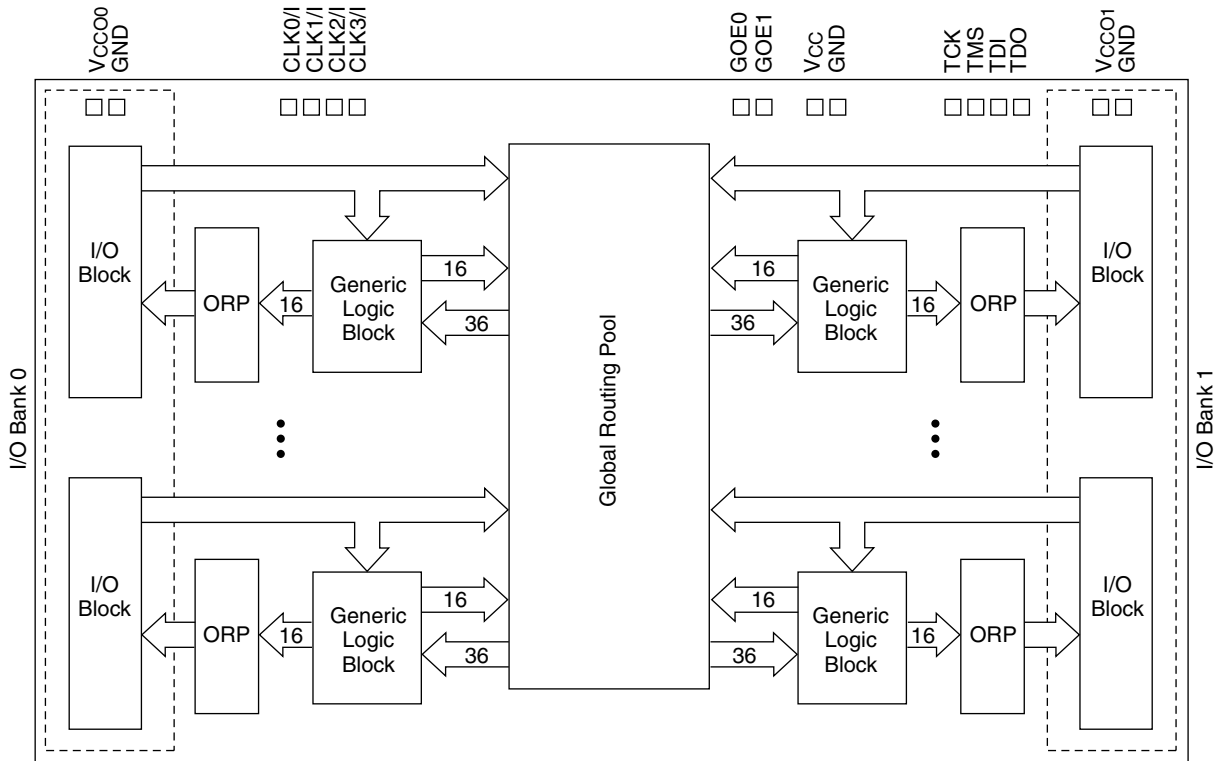

The I/Os in the ispMACH 4000 are split into two banks. Each bank has a separate I/O power supply. Inputs can support a variety of standards independent of the chip or bank power supply. Outputs support the standards compatible with the power supply provided to the bank. Support for a variety of standards helps designers implement designs in mixed voltage environments. In addition, 5V tolerant inputs are specified within an I/O bank that is connected to V_{CC0} of 3.0V to 3.6V for LVCMOS 3.3, LVTTTL and PCI interfaces.

ispMACH 4000 Architecture

There are a total of two GLBs in the ispMACH 4032, increasing to 32 GLBs in the ispMACH 4512. Each GLB has 36 inputs. All GLB inputs come from the GRP and all outputs from the GLB are brought back into the GRP to be connected to the inputs of any other GLB on the device. Even if feedback signals return to the same GLB, they still must go through the GRP. This mechanism ensures that GLBs communicate with each other with consistent and predictable delays. The outputs from the GLB are also sent to the ORP. The ORP then sends them to the associated I/O cells in the I/O block.

Generic Logic Block

The ispMACH 4000 GLB consists of a programmable AND array, logic allocator, 16 macrocells and a GLB clock generator. Macrocells are decoupled from the product terms through the logic allocator and the I/O pins are decoupled from macrocells through the ORP. Figure 2 illustrates the GLB.

Figure 2. Generic Logic Block

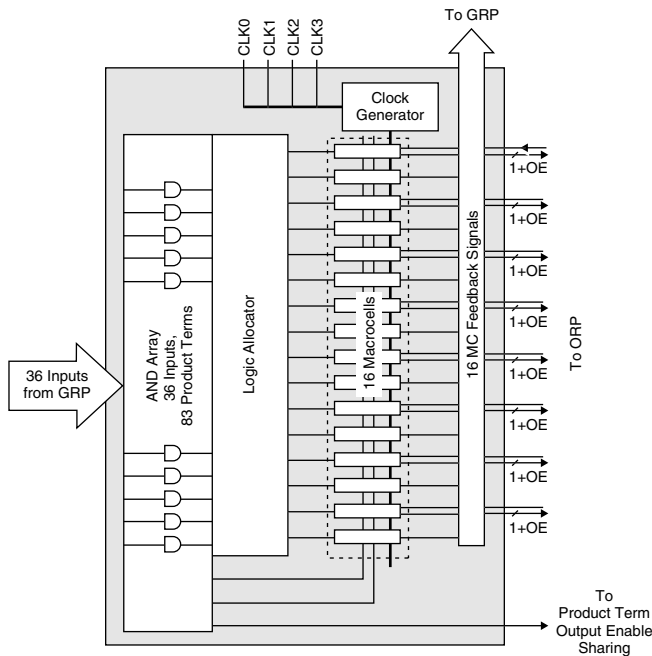

AND Array

The programmable AND Array consists of 36 inputs and 83 output product terms. The 36 inputs from the GRP are used to form 72 lines in the AND Array (true and complement of the inputs). Each line in the array can be connected to any of the 83 output product terms via a wired-AND. Each of the 80 logic product terms feed the logic allocator with the remaining three control product terms feeding the Shared PT Clock, Shared PT Initialization and Shared PT OE. The Shared PT Clock and Shared PT Initialization signals can optionally be inverted before being fed to the macrocells.

Every set of five product terms from the 80 logic product terms forms a product term cluster starting with PT0. There is one product term cluster for every macrocell in the GLB. Figure 3 is a graphical representation of the AND Array.

Figure 3. AND Array

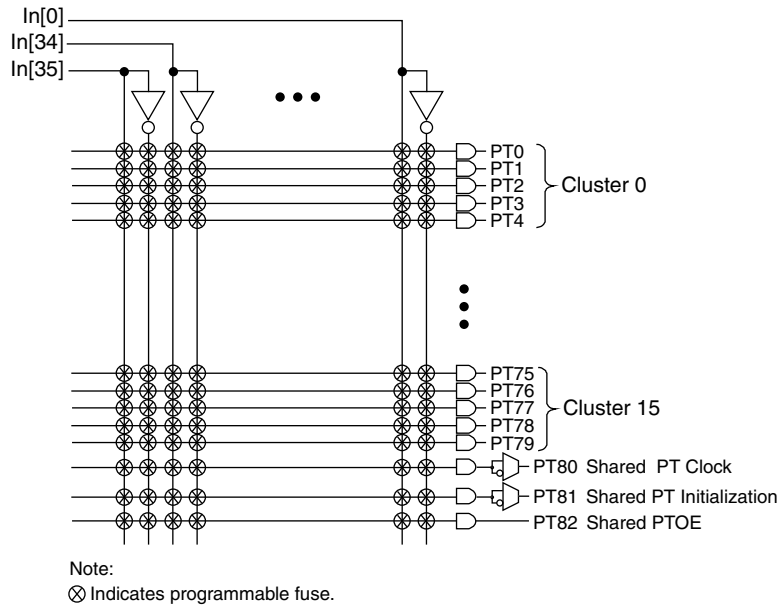

Enhanced Logic Allocator

Within the logic allocator, product terms are allocated to macrocells in product term clusters. Each product term cluster is associated with a macrocell. The cluster size for the ispMACH 4000 family is 4+1 (total 5) product terms. The software automatically considers the availability and distribution of product term clusters as it fits the functions within a GLB. The logic allocator is designed to provide three speed paths: 5-PT fast bypass path, 20-PT Speed Locking path and an up to 80-PT path. The availability of these three paths lets designers trade timing variability for increased performance.

The enhanced Logic Allocator of the ispMACH 4000 family consists of the following blocks:

- Product Term Allocator
- Cluster Allocator
- Wide Steering Logic

Figure 4 shows a macrocell slice of the Logic Allocator. There are 16 such slices in the GLB.

Figure 4. Macrocell Slice

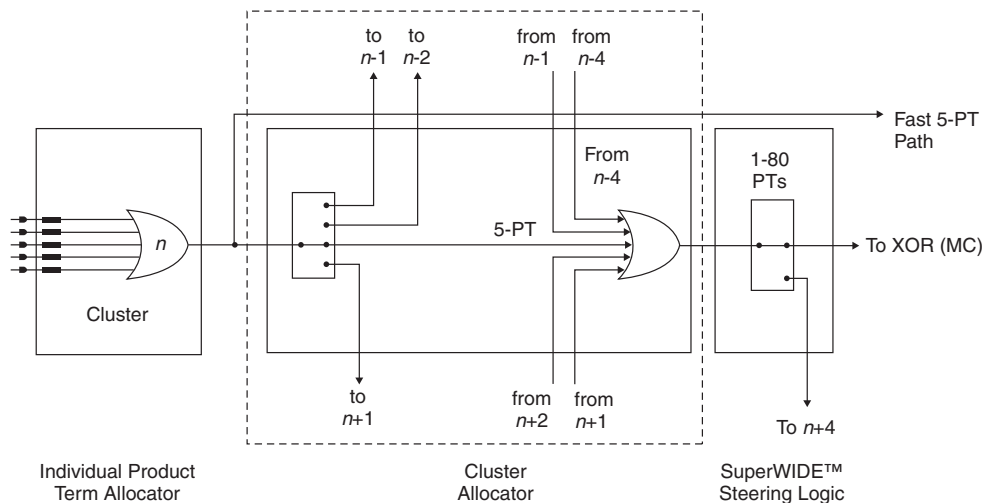

Product Term Allocator

The product term allocator assigns product terms from a cluster to either logic or control applications as required by the design being implemented. Product terms that are used as logic are steered into a 5-input OR gate associated with the cluster. Product terms that used for control are steered either to the macrocell or I/O cell associated with the cluster. Table 3 shows the available functions for each of the five product terms in the cluster. The OR gate output connects to the associated I/O cell, providing a fast path for narrow combinatorial functions, and to the logic allocator.

Table 3. Individual PT Steering

Product Term	Logic	Control
PT n	Logic PT	Single PT for XOR/OR
PT $n+1$	Logic PT	Individual Clock (PT Clock)
PT $n+2$	Logic PT	Individual Initialization or Individual Clock Enable (PT Initialization/CE)
PT $n+3$	Logic PT	Individual Initialization (PT Initialization)
PT $n+4$	Logic PT	Individual OE (PTOE)

Cluster Allocator

The cluster allocator allows clusters to be steered to neighboring macrocells, thus allowing the creation of functions with more product terms. Table 4 shows which clusters can be steered to which macrocells. Used in this manner, the cluster allocator can be used to form functions of up to 20 product terms. Additionally, the cluster allocator accepts inputs from the wide steering logic. Using these inputs, functions up to 80 product terms can be created.

Table 4. Available Clusters for Each Macrocell

Macrocell	Available Clusters			
M0	—	C0	C1	C2
M1	C0	C1	C2	C3
M2	C1	C2	C3	C4
M3	C2	C3	C4	C5
M4	C3	C4	C5	C6
M5	C4	C5	C6	C7
M6	C5	C6	C7	C8
M7	C6	C7	C8	C9
M8	C7	C8	C9	C10
M9	C8	C9	C10	C11
M10	C9	C10	C11	C12
M11	C10	C11	C12	C13
M12	C11	C12	C13	C14
M13	C12	C13	C14	C15
M14	C13	C14	C15	—
M15	C14	C15	—	—

Wide Steering Logic

The wide steering logic allows the output of the cluster allocator n to be connected to the input of the cluster allocator $n+4$. Thus, cluster chains can be formed with up to 80 product terms, supporting wide product term functions and allowing performance to be increased through a single GLB implementation. Table 5 shows the product term chains.

Table 5. Product Term Expansion Capability

Expansion Chains	Macrocells Associated with Expansion Chain (with Wrap Around)	Max PT/Macrocell
Chain-0	M0 M4 M8 M12 M0	75
Chain-1	M1 M5 M9 M13 M1	80
Chain-2	M2 M6 M10 M14 M2	75
Chain-3	M3 M7 M11 M15 M3	70

Every time the super cluster allocator is used, there is an incremental delay of t_{EXP} . When the super cluster allocator is used, all destinations other than the one being steered to, are given the value of ground (i.e., if the super cluster is steered to M (n+4), then M (n) is ground).

Macrocell

The 16 macrocells in the GLB are driven by the 16 outputs from the logic allocator. Each macrocell contains a programmable XOR gate, a programmable register/latch, along with routing for the logic and control functions. Figure 5 shows a graphical representation of the macrocell. The macrocells feed the ORP and GRP. A direct input from the I/O cell allows designers to use the macrocell to construct high-speed input registers. A programmable delay in this path allows designers to choose between the fastest possible set-up time and zero hold time.

Figure 5. Macrocell

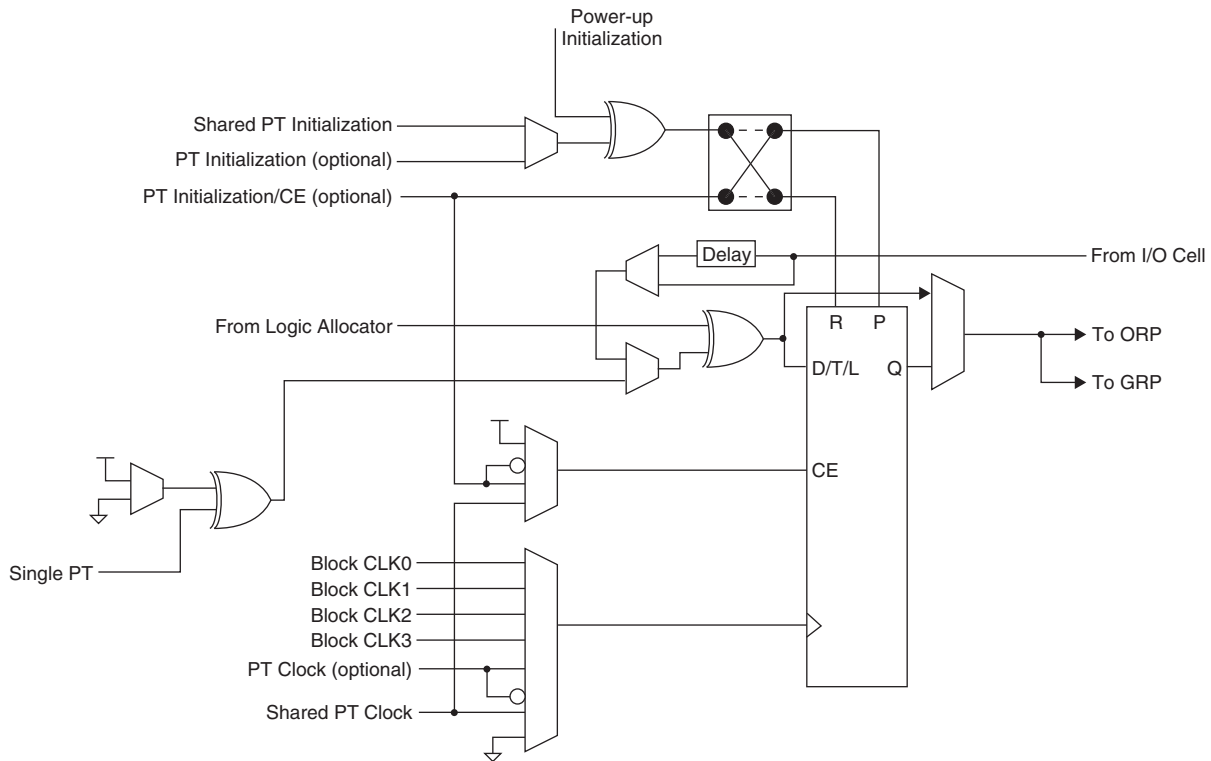

Enhanced Clock Multiplexer

The clock input to the flip-flop can select any of the four block clocks along with the shared PT clock, and true and complement forms of the optional individual term clock. An 8:1 multiplexer structure is used to select the clock. The eight sources for the clock multiplexer are as follows:

- Block CLK0
- Block CLK1

ispMACH 4000V/B/C External Switching Characteristics (Cont.)

Over Recommended Operating Conditions

Parameter	Description ^{1, 2, 3}	-5		-75		-10		Units
		Min.	Max.	Min.	Max.	Min.	Max.	
t _{PD}	5-PT bypass combinatorial propagation delay	—	5.0	—	7.5	—	10.0	ns
t _{PD_MC}	20-PT combinatorial propagation delay through macrocell	—	5.5	—	8.0	—	10.5	ns
t _S	GLB register setup time before clock	3.0	—	4.5	—	5.5	—	ns
t _{ST}	GLB register setup time before clock with T-type register	3.2	—	4.7	—	5.5	—	ns
t _{SIR}	GLB register setup time before clock, input register path	1.2	—	1.7	—	1.7	—	ns
t _{SIRZ}	GLB register setup time before clock with zero hold	2.2	—	2.7	—	2.7	—	ns
t _H	GLB register hold time after clock	0.0	—	0.0	—	0.0	—	ns
t _{HT}	GLB register hold time after clock with T-type register	0.0	—	0.0	—	0.0	—	ns
t _{HIR}	GLB register hold time after clock, input register path	1.0	—	1.0	—	1.0	—	ns
t _{HIRZ}	GLB register hold time after clock, input register path with zero hold	0.0	—	0.0	—	0.0	—	ns
t _{CO}	GLB register clock-to-output delay	—	3.4	—	4.5	—	6.0	ns
t _R	External reset pin to output delay	—	6.3	—	9.0	—	10.5	ns
t _{RW}	External reset pulse duration	2.0	—	4.0	—	4.0	—	ns
t _{P_{TOE/DIS}}	Input to output local product term output enable/disable	—	7.0	—	9.0	—	10.5	ns
t _{G_{P_{TOE/DIS}}}	Input to output global product term output enable/disable	—	9.0	—	10.3	—	12.0	ns
t _{GOE/DIS}	Global OE input to output enable/disable	—	5.0	—	7.0	—	8.0	ns
t _{CW}	Global clock width, high or low	2.2	—	2.8	—	4.0	—	ns
t _{GW}	Global gate width low (for low transparent) or high (for high transparent)	2.2	—	2.8	—	4.0	—	ns
t _{WIR}	Input register clock width, high or low	2.2	—	2.8	—	4.0	—	ns
f _{MAX} ⁴	Clock frequency with internal feedback	—	227	—	168	—	125	MHz
f _{MAX} (Ext.)	Clock frequency with external feedback, [1/ (t _S + t _{CO})]	—	156	—	111	—	86	MHz

1. Timing numbers are based on default LVCMOS 1.8 I/O buffers. Use timing adjusters provided to calculate other standards.

Timing v.3.2

2. Measured using standard switching circuit, assuming GRP loading of 1 and 1 output switching.

3. Pulse widths and clock widths less than minimum will cause unknown behavior.

4. Standard 16-bit counter using GRP feedback.

ispMACH 4000Z External Switching Characteristics (Cont.)

Over Recommended Operating Conditions

Parameter	Description ^{1, 2, 3}	-45		-5		-75		Units
		Min.	Max.	Min.	Max.	Min.	Max.	
t _{PD}	5-PT bypass combinatorial propagation delay	—	4.5	—	5.0	—	7.5	ns
t _{PD_MC}	20-PT combinatorial propagation delay through macrocell	—	5.8	—	6.0	—	8.0	ns
t _S	GLB register setup time before clock	2.9	—	3.0	—	4.5	—	ns
t _{ST}	GLB register setup time before clock with T-type register	3.1	—	3.2	—	4.7	—	ns
t _{SIR}	GLB register setup time before clock, input register path	1.3	—	1.3	—	1.4	—	ns
t _{SIRZ}	GLB register setup time before clock with zero hold	2.6	—	2.6	—	2.7	—	ns
t _H	GLB register hold time after clock	0.0	—	0.0	—	0.0	—	ns
t _{HT}	GLB register hold time after clock with T-type register	0.0	—	0.0	—	0.0	—	ns
t _{HIR}	GLB register hold time after clock, input register path	1.3	—	1.3	—	1.3	—	ns
t _{HIRZ}	GLB register hold time after clock, input register path with zero hold	0.0	—	0.0	—	0.0	—	ns
t _{CO}	GLB register clock-to-output delay	—	3.8	—	4.2	—	4.5	ns
t _R	External reset pin to output delay	—	7.5	—	7.5	—	9.0	ns
t _{RW}	External reset pulse duration	2.0	—	2.0	—	4.0	—	ns
t _{P_{TOE/DIS}}	Input to output local product term output enable/disable	—	8.2	—	8.5	—	9.0	ns
t _{G_{P_{TOE/DIS}}}	Input to output global product term output enable/disable	—	10.0	—	10.0	—	10.5	ns
t _{G_{OE/DIS}}	Global OE input to output enable/disable	—	5.5	—	6.0	—	7.0	ns
t _{CW}	Global clock width, high or low	1.8	—	2.0	—	2.8	—	ns
t _{GW}	Global gate width low (for low transparent) or high (for high transparent)	1.8	—	2.0	—	2.8	—	ns
t _{WIR}	Input register clock width, high or low	1.8	—	2.0	—	2.8	—	ns
f _{MAX} ⁴	Clock frequency with internal feedback	—	200	—	200	—	168	MHz
f _{MAX} (Ext.)	clock frequency with external feedback, [1 / (t _S + t _{CO})]	—	150	—	139	—	111	MHz

1. Timing numbers are based on default LVCMOS 1.8 I/O buffers. Use timing adjusters provided to calculate other standards.

Timing v.2.2

2. Measured using standard switching GRP loading of 1 and 1 output switching.

3. Pulse widths and clock widths less than minimum will cause unknown behavior.

4. Standard 16-bit counter using GRP feedback.

Timing Model

The task of determining the timing through the ispMACH 4000 family, like any CPLD, is relatively simple. The timing model provided in Figure 11 shows the specific delay paths. Once the implementation of a given function is determined either conceptually or from the software report file, the delay path of the function can easily be determined from the timing model. The Lattice design tools report the timing delays based on the same timing model for a particular design. Note that the internal timing parameters are given for reference only, and are not tested. The external timing parameters are tested and guaranteed for every device. For more information on the timing model and usage, refer to TN1004, [ispMACH 4000 Timing Model Design and Usage Guidelines](#).

Figure 11. ispMACH 4000 Timing Model

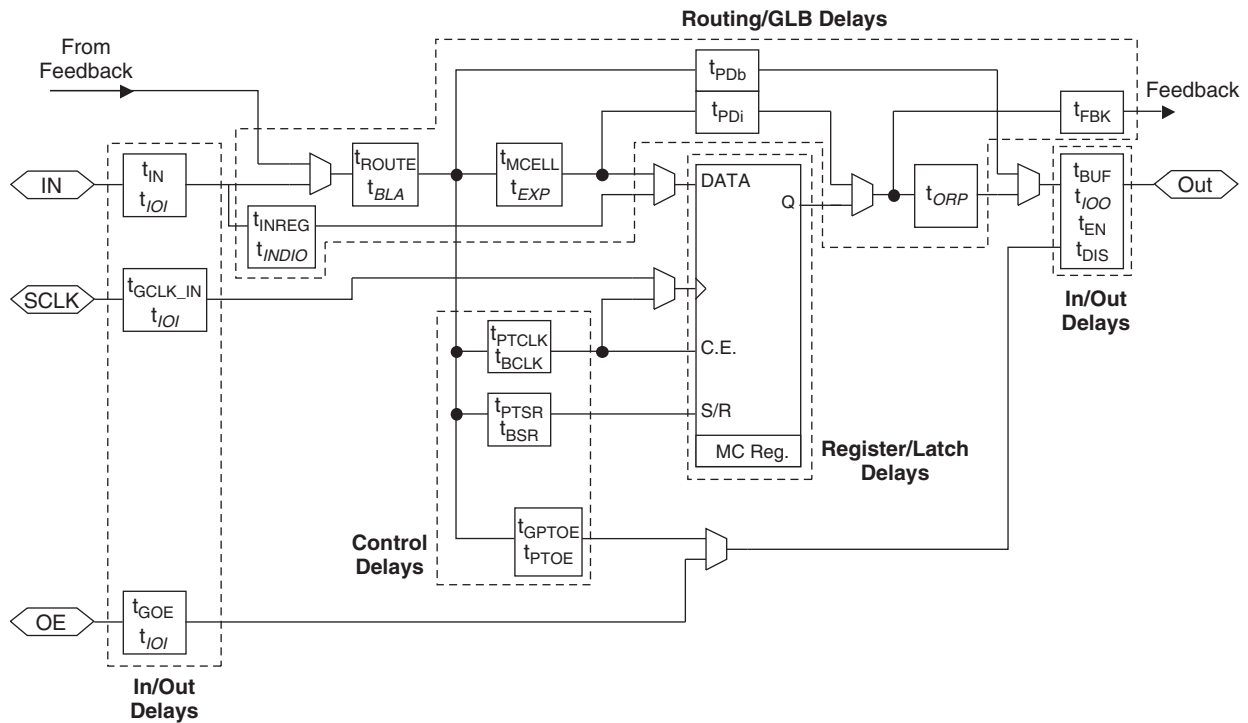

Note: Italicized items are optional delay adders.

ispMACH 4000V/B/C Internal Timing Parameters

Over Recommended Operating Conditions

Parameter	Description	-2.5	-2.7	-3	-3.5	Units
In/Out Delays						
t_{IN}	Input Buffer Delay	—	0.60	—	0.60	ns
t_{GOE}	Global OE Pin Delay	—	2.04	—	2.54	ns
t_{GCLK_IN}	Global Clock Input Buffer Delay	—	0.78	—	1.28	ns
t_{BUF}	Delay through Output Buffer	—	0.85	—	0.85	ns
t_{EN}	Output Enable Time	—	0.96	—	0.96	ns
t_{DIS}	Output Disable Time	—	0.96	—	0.96	ns
Routing/GLB Delays						
t_{ROUTE}	Delay through GRP	—	0.61	—	0.81	ns
t_{MCELL}	Macrocell Delay	—	0.45	—	0.55	ns
t_{INREG}	Input Buffer to Macrocell Register Delay	—	0.11	—	0.31	ns
t_{FBK}	Internal Feedback Delay	—	0.00	—	0.00	ns
t_{PDb}	5-PT Bypass Propagation Delay	—	0.44	—	0.44	ns
t_{PDi}	Macrocell Propagation Delay	—	0.64	—	0.64	ns
Register/Latch Delays						
t_S	D-Register Setup Time (Global Clock)	0.92	—	1.12	—	ns
t_{S_PT}	D-Register Setup Time (Product Term Clock)	1.42	—	1.32	—	ns
t_{ST}	T-Register Setup Time (Global Clock)	1.12	—	1.32	—	ns
t_{ST_PT}	T-Register Setup Time (Product Term Clock)	1.42	—	1.32	—	ns
t_H	D-Register Hold Time	0.88	—	0.68	—	ns
t_{HT}	T-Register Hold Time	0.88	—	0.68	—	ns
t_{SIR}	D-Input Register Setup Time (Global Clock)	0.82	—	1.37	—	ns
t_{SIR_PT}	D-Input Register Setup Time (Product Term Clock)	1.45	—	1.45	—	ns
t_{HIR}	D-Input Register Hold Time (Global Clock)	0.88	—	0.63	—	ns
t_{HIR_PT}	D-Input Register Hold Time (Product Term Clock)	0.88	—	0.63	—	ns
t_{COi}	Register Clock to Output/Feedback MUX Time	—	0.52	—	0.52	ns
t_{CES}	Clock Enable Setup Time	2.25	—	2.25	—	ns
t_{CEH}	Clock Enable Hold Time	1.88	—	1.88	—	ns
t_{SL}	Latch Setup Time (Global Clock)	0.92	—	1.12	—	ns
t_{SL_PT}	Latch Setup Time (Product Term Clock)	1.42	—	1.32	—	ns
t_{HL}	Latch Hold Time	1.17	—	1.17	—	ns
t_{GOi}	Latch Gate to Output/Feedback MUX Time	—	0.33	—	0.33	ns

ispMACH 4000V/B/C Internal Timing Parameters

Over Recommended Operating Conditions

Parameter	Description	-5		-75		-10		Units
		Min.	Max.	Min.	Max.	Min.	Max.	
In/Out Delays								
t _{IN}	Input Buffer Delay	—	0.95	—	1.50	—	2.00	ns
t _{GOE}	Global OE Pin Delay	—	4.04	—	6.04	—	7.04	ns
t _{GCLK_IN}	Global Clock Input Buffer Delay	—	1.83	—	2.28	—	3.28	ns
t _{BUF}	Delay through Output Buffer	—	1.00	—	1.50	—	1.50	ns
t _{EN}	Output Enable Time	—	0.96	—	0.96	—	0.96	ns
t _{DIS}	Output Disable Time	—	0.96	—	0.96	—	0.96	ns
Routing/GLB Delays								
t _{ROUTE}	Delay through GRP	—	1.51	—	2.26	—	3.26	ns
t _{MCELL}	Macrocell Delay	—	1.05	—	1.45	—	1.95	ns
t _{INREG}	Input Buffer to Macrocell Register Delay	—	0.56	—	0.96	—	1.46	ns
t _{FBK}	Internal Feedback Delay	—	0.00	—	0.00	—	0.00	ns
t _{PDb}	5-PT Bypass Propagation Delay	—	1.54	—	2.24	—	3.24	ns
t _{PDi}	Macrocell Propagation Delay	—	0.94	—	1.24	—	1.74	ns
Register/Latch Delays								
t _S	D-Register Setup Time (Global Clock)	1.32	—	1.57	—	1.57	—	ns
t _{S_PT}	D-Register Setup Time (Product Term Clock)	1.32	—	1.32	—	1.32	—	ns
t _{ST}	T-Register Setup Time (Global Clock)	1.52	—	1.77	—	1.77	—	ns
t _{ST_PT}	T-Register Setup Time (Product Term Clock)	1.32	—	1.32	—	1.32	—	ns
t _H	D-Register Hold Time	1.68	—	2.93	—	3.93	—	ns
t _{HT}	T-Register Hold Time	1.68	—	2.93	—	3.93	—	ns
t _{SIR}	D-Input Register Setup Time (Global Clock)	1.52	—	1.57	—	1.57	—	ns
t _{SIR_PT}	D-Input Register Setup Time (Product Term Clock)	1.45	—	1.45	—	1.45	—	ns
t _{HIR}	D-Input Register Hold Time (Global Clock)	0.68	—	1.18	—	1.18	—	ns
t _{HIR_PT}	D-Input Register Hold Time (Product Term Clock)	0.68	—	1.18	—	1.18	—	ns
t _{COi}	Register Clock to Output/Feedback MUX Time	—	0.52	—	0.67	—	1.17	ns
t _{CES}	Clock Enable Setup Time	2.25	—	2.25	—	2.25	—	ns
t _{CEH}	Clock Enable Hold Time	1.88	—	1.88	—	1.88	—	ns
t _{SL}	Latch Setup Time (Global Clock)	1.32	—	1.57	—	1.57	—	ns
t _{SL_PT}	Latch Setup Time (Product Term Clock)	1.32	—	1.32	—	1.32	—	ns
t _{HL}	Latch Hold Time	1.17	—	1.17	—	1.17	—	ns
t _{GOi}	Latch Gate to Output/Feedback MUX Time	—	0.33	—	0.33	—	0.33	ns
t _{PDLi}	Propagation Delay through Transparent Latch to Output/Feedback MUX	—	0.25	—	0.25	—	0.25	ns
t _{SRI}	Asynchronous Reset or Set to Output/Feedback MUX Delay	0.28	—	0.28	—	0.28	—	ns
t _{SRR}	Asynchronous Reset or Set Recovery Time	1.67	—	1.67	—	1.67	—	ns
Control Delays								
t _{BCLK}	GLB PT Clock Delay	—	1.12	—	1.12	—	0.62	ns
t _{PTCLK}	Macrocell PT Clock Delay	—	0.87	—	0.87	—	0.87	ns
t _{BSR}	GLB PT Set/Reset Delay	—	1.83	—	1.83	—	1.83	ns
t _{PTSR}	Macrocell PT Set/Reset Delay	—	2.51	—	3.41	—	3.41	ns

Signal Descriptions

Signal Names	Description	
TMS	Input – This pin is the IEEE 1149.1 Test Mode Select input, which is used to control the state machine.	
TCK	Input – This pin is the IEEE 1149.1 Test Clock input pin, used to clock through the state machine.	
TDI	Input – This pin is the IEEE 1149.1 Test Data In pin, used to load data.	
TDO	Output – This pin is the IEEE 1149.1 Test Data Out pin used to shift data out.	
GOE0/IO, GOE1/IO	These pins are configured to be either Global Output Enable Input or as general I/O pins.	
GND	Ground	
NC	Not Connected	
V _{CC}	The power supply pins for logic core and JTAG port.	
CLK0/I, CLK1/I, CLK2/I, CLK3/I	These pins are configured to be either CLK input or as an input.	
V _{CC00} , V _{CC01}	The power supply pins for each I/O bank.	
yzz	Input/Output ¹ – These are the general purpose I/O used by the logic array. y is GLB reference (alpha) and z is macrocell reference (numeric). z: 0-15.	
	ispMACH 4032	y: A-B
	ispMACH 4064	y: A-D
	ispMACH 4128	y: A-H
	ispMACH 4256	y: A-P
	ispMACH 4384	y: A-P, AX-HX
ispMACH 4512	y: A-P, AX-PX	

1. In some packages, certain I/Os are only available for use as inputs. See the signal connections table for details.

ispMACH 4000V/B/C ORP Reference Table

	4032V/B/C		4064V/B/C			4128V/B/C			4256V/B/C				4384V/B/C		4512V/B/C	
Number of I/Os	30 ¹	32	30 ²	32	64	64	92 ³	96	64	96 ⁴	128	160	128	192	128	208
Number of GLBs	2	2	4	4	4	8	8	8	16	16	16	16	16	16	16	16
Number of I/Os / GLB	16	16	8	8	16	8	12	12	4	8	8	10	8	8	8	Mixture of 8 & 4 ⁵
Reference ORP Table	16 I/Os / GLB		8 I/Os / GLB		16 I/Os / GLB	8 I/Os / GLB	12 I/Os / GLB	4 I/Os / GLB	8 I/Os / GLB	8 I/Os / GLB	10 I/Os / GLB	8 I/Os / GLB	8 I/Os / GLB	8 I/Os / GLB	8 I/Os / GLB 4 I/Os / GLB	

- 32-macrocell device, 44 TQFP: 2 GLBs have 15 out of 16 I/Os bonded out.
- 64-macrocells device, 44 TQFP: 2 GLBs have 7 out of 8 I/Os bonded out.
- 128-macrocell device, 128 TQFP: 4 GLBs have 11 out of 12 I/Os
- 256-macrocell device, 144 TQFP: 16 GLBs have 6 I/Os per
- 512-macrocell device: 20 GLBs have 8 I/Os per, 12 GLBs have 4 I/Os per

ispMACH 4000Z ORP Reference Table

	4032Z	4064Z		4128Z		4256Z		
Number of I/Os	32	32	64	64	96	64	96 ¹	128
Number of GLBs	2	4	4	8	8	16	16	16
Number of I/Os / GLB	16	8	16	8	12	4	8	8
Reference ORP Table	16 I/Os / GLB	8 I/Os / GLB	16 I/Os / GLB	8 I/Os / GLB	12 I/Os / GLB	4 I/Os / GLB	8 I/Os / GLB	8 I/Os / GLB

- 256-macrocell device, 132 csBGA: 16 GLBs have 6 I/Os per

**ispMACH 4032V/B/C and 4064V/B/C Logic Signal Connections:
44-Pin TQFP (Cont.)**

Pin Number	Bank Number	ispMACH 4032V/B/C		ispMACH 4064V/B/C	
		GLB/MC/Pad	ORP	GLB/MC/Pad	ORP
42	0	A2	A ²	A4	A ²
43	0	A3	A ³	A6	A ³
44	0	A4	A ⁴	A8	A ⁴

**ispMACH 4032V/B/C/Z and 4064V/B/C/Z Logic Signal Connections:
48-Pin TQFP**

Pin Number	Bank Number	ispMACH 4032V/B/C/Z		ispMACH 4064V/B/C		ispMACH 4064Z	
		GLB/MC/Pad	ORP	GLB/MC/Pad	ORP	GLB/MC/Pad	ORP
1	-	TDI	-	TDI	-	TDI	-
2	0	A5	A ⁵	A10	A ⁵	A8	A ⁵
3	0	A6	A ⁶	A12	A ⁶	A10	A ⁶
4	0	A7	A ⁷	A14	A ⁷	A11	A ⁷
5	0	GND (Bank 0)	-	GND (Bank 0)	-	GND (Bank 0)	-
6	0	VCCO (Bank 0)	-	VCCO (Bank 0)	-	VCCO (Bank 0)	-
7	0	A8	A ⁸	B0	B ⁰	B15	B ⁷
8	0	A9	A ⁹	B2	B ¹	B12	B ⁶
9	0	A10	A ¹⁰	B4	B ²	B10	B ⁵
10	0	A11	A ¹¹	B6	B ³	B8	B ⁴
11	-	TCK	-	TCK	-	TCK	-
12	-	VCC	-	VCC	-	VCC	-
13	-	GND	-	GND	-	GND	-
14	0	A12	A ¹²	B8	B ⁴	B6	B ³
15	0	A13	A ¹³	B10	B ⁵	B4	B ²
16	0	A14	A ¹⁴	B12	B ⁶	B2	B ¹
17	0	A15	A ¹⁵	B14	B ⁷	B0	B ⁰
18	0	CLK1/I	-	CLK1/I	-	CLK1/I	-
19	1	CLK2/I	-	CLK2/I	-	CLK2/I	-
20	1	B0	B ⁰	C0	C ⁰	C0	C ⁰
21	1	B1	B ¹	C2	C ¹	C1	C ¹
22	1	B2	B ²	C4	C ²	C2	C ²
23	1	B3	B ³	C6	C ³	C4	C ³
24	1	B4	B ⁴	C8	C ⁴	C6	C ⁴
25	-	TMS	-	TMS	-	TMS	-
26	1	B5	B ⁵	C10	C ⁵	C8	C ⁵
27	1	B6	B ⁶	C12	C ⁶	C10	C ⁶
28	1	B7	B ⁷	C14	C ⁷	C11	C ⁷
29	1	GND (Bank 1)	-	GND (Bank 1)	-	GND (Bank 1)	-
30	1	VCCO (Bank 1)	-	VCCO (Bank 1)	-	VCCO (Bank 1)	-
31	1	B8	B ⁸	D0	D ⁰	D15	D ⁷
32	1	B9	B ⁹	D2	D ¹	D12	D ⁶

**ispMACH 4064Z, 4128Z and 4256Z Logic Signal Connections:
132-Ball csBGA (Cont.)**

Ball Number	Bank Number	ispMACH 4064Z		ispMACH 4128Z		ispMACH 4256Z	
		GLB/MC/Pad	ORP	GLB/MC/Pad	ORP	GLB/MC/Pad	ORP
E3	0	NC	-	B8	B^6	D12	D^6
F2	0	A12	A^12	B9	B^7	D10	D^5
F1	0	A13	A^13	B10	B^8	D8	D^4
F3	0	A14	A^14	B12	B^9	D6	D^3
G1	0	A15	A^15	B13	B^10	D4	D^2
G2	0	I	-	B14	B^11	D2	D^1
G3	0	VCCO (Bank 0)	-	VCCO (Bank 0)	-	VCCO (Bank 0)	-
H2	0	NC	-	C14	C^11	E2	E^1
H1	0	B15	B^15	C13	C^10	E4	E^2
H3	0	B14	B^14	C12	C^9	E6	E^3
J1	0	B13	B^13	C10	C^8	E8	E^4
J2	0	B12	B^12	C9	C^7	E10	E^5
J3	0	NC	-	C8	C^6	E12	E^6
K2	0	GND (Bank 0)	-	GND (Bank 0)	-	GND (Bank 0)	-
K1	0	NC	-	C6	C^5	F2	F^1
K3	0	B11	B^11	C5	C^4	F4	F^2
L2	0	B10	B^10	C4	C^3	F6	F^3
L1	0	B9	B^9	C2	C^2	F8	F^4
L3	0	B8	B^8	C1	C^1	F10	F^5
M1	0	I	-	C0	C^0	F12	F^6
M2	0	NC	-	VCCO (Bank 0)	-	VCCO (Bank 0)	-
N1	-	TCK	-	TCK	-	TCK	-
P1	-	VCC	-	VCC	-	VCC	-
P2	-	GND	-	GND	-	GND	-
N2	0	I	-	D14	D^11	G12	G^6
P3	0	B7	B^7	D13	D^10	G10	G^5
M3	0	B6	B^6	D12	D^9	G8	G^4
N3	0	B5	B^5	D10	D^8	G6	G^3
P4	0	B4	B^4	D9	D^7	G4	G^2
M4	0	NC	-	D8	D^6	G2	G^1
N4	0	GND (Bank 0)	-	GND (Bank 0)	-	GND (Bank 0)	-
P5	0	VCCO (Bank 0)	-	VCCO (Bank 0)	-	VCCO (Bank 0)	-
N5	0	NC	-	D6	D^5	H12	H^6
M5	0	B3	B^3	D5	D^4	H10	H^5
N6	0	B2	B^2	D4	D^3	H8	H^4
P6	0	B1	B^1	D2	D^2	H6	H^3
M6	0	B0	B^0	D1	D^1	H4	H^2
P7	0	NC	-	D0	D^0	H2	H^1
N7	0	CLK1/I	-	CLK1/I	-	CLK1/I	-
M7	1	CLK2/I	-	CLK2/I	-	CLK2/I	-
N8	-	VCC	-	VCC	-	VCC	-

**ispMACH 4064Z, 4128Z and 4256Z Logic Signal Connections:
132-Ball csBGA (Cont.)**

Ball Number	Bank Number	ispMACH 4064Z		ispMACH 4128Z		ispMACH 4256Z	
		GLB/MC/Pad	ORP	GLB/MC/Pad	ORP	GLB/MC/Pad	ORP
P8	1	NC ¹	-	NC ¹	-	I ¹	-
M8	1	NC	-	E0	E ⁰	I2	I ¹
P9	1	C0	C ⁰	E1	E ¹	I4	I ²
N9	1	C1	C ¹	E2	E ²	I6	I ³
M9	1	C2	C ²	E4	E ³	I8	I ⁴
N10	1	C3	C ³	E5	E ⁴	I10	I ⁵
P10	1	NC	-	E6	E ⁵	I12	I ⁶
M10	1	VCCO (Bank 1)	-	VCCO (Bank 1)	-	VCCO (Bank 1)	-
N11	1	GND (Bank 1)	-	GND (Bank 1)	-	GND (Bank 1)	-
P11	1	NC	-	E8	E ⁶	J2	J ¹
M11	1	C4	C ⁴	E9	E ⁷	J4	J ²
P12	1	C5	C ⁵	E10	E ⁸	J6	J ³
N12	1	C6	C ⁶	E12	E ⁹	J8	J ⁴
P13	1	C7	C ⁷	E13	E ¹⁰	J10	J ⁵
P14	1	NC	-	E14	E ¹¹	J12	J ⁶
N14	-	GND	-	GND	-	GND	-
N13	-	TMS	-	TMS	-	TMS	-
M14	1	NC	-	VCCO (Bank 1)	-	VCCO (Bank 1)	-
M12	1	NC	-	F0	F ⁰	K12	K ⁶
M13	1	C8	C ⁸	F1	F ¹	K10	K ⁵
L14	1	C9	C ⁹	F2	F ²	K8	K ⁴
L12	1	C10	C ¹⁰	F4	F ³	K6	K ³
L13	1	C11	C ¹¹	F5	F ⁴	K4	K ²
K14	1	NC	-	F6	F ⁵	K2	K ¹
K13	1	GND (Bank 1)	-	GND (Bank 1)	-	GND (Bank 1)	-
K12	1	NC	-	F8	F ⁶	L12	L ⁶
J13	1	C12	C ¹²	F9	F ⁷	L10	L ⁵
J14	1	C13	C ¹³	F10	F ⁸	L8	L ⁴
J12	1	C14	C ¹⁴	F12	F ⁹	L6	L ³
H14	1	C15	C ¹⁵	F13	F ¹⁰	L4	L ²
H13	1	I	-	F14	F ¹¹	L2	L ¹
H12	1	VCCO (Bank 1)	-	VCCO (Bank 1)	-	VCCO (Bank 1)	-
G13	1	NC	-	G14	G ¹¹	M2	M ¹
G14	1	NC	-	G13	G ¹⁰	M4	M ²
G12	1	D15	D ¹⁵	G12	G ⁹	M6	M ³
F14	1	D14	D ¹⁴	G10	G ⁸	M8	M ⁴
F13	1	D13	D ¹³	G9	G ⁷	M10	M ⁵
F12	1	D12	D ¹²	G8	G ⁶	M12	M ⁶
E13	1	GND (Bank 1)	-	GND (Bank 1)	-	GND (Bank 1)	-
E14	1	NC	-	G6	G ⁵	N2	N ¹
E12	1	D11	D ¹¹	G5	G ⁴	N4	N ²

**ispMACH 4256V/B/C, 4384V/B/C, 4512V/B/C Logic Signal Connections:
256-Ball ftBGA/fpBGA**

Ball Number	I/O Bank	ispMACH 4256V/B/C 128-I/O		ispMACH 4256V/B/C 160-I/O		ispMACH 4384V/B/C		ispMACH 4512V/B/C	
		GLB/MC/Pad	ORP	GLB/MC/Pad	ORP	GLB/MC/Pad	ORP	GLB/MC/Pad	ORP
-	-	-	-	-	-	VCC	-	VCC	-
-	-	GND	-	GND	-	GND	-	GND	-
C3	-	TDI	-	TDI	-	TDI	-	TDI	-
-	0	VCCO (Bank 0)	-	VCCO (Bank 0)	-	VCCO (Bank 0)	-	VCCO (Bank 0)	-
B1	0	C14	C^7	C14	C^9	C14	C^7	C14	C^7
F5	0	C12	C^6	C12	C^8	C12	C^6	C12	C^6
D3	0	C10	C^5	C10	C^7	C10	C^5	C10	C^5
C1	0	C8	C^4	C9	C^6	C8	C^4	C8	C^4
C2	0	C6	C^3	C8	C^5	C6	C^3	C6	C^3
E3	0	C4	C^2	C6	C^4	C4	C^2	C4	C^2
D2	0	C2	C^1	C4	C^3	C2	C^1	C2	C^1
F6	0	C0	C^0	C2	C^2	C0	C^0	C0	C^0
D1	0	NC	-	C1	C^1	F6	F^3	H0	H^0
E2	0	NC	-	C0	C^0	F4	F^2	H4	H^1
E4	0	NC	-	NC	-	D6	D^3	F4	F^2
G5	0	NC	-	NC	-	D4	D^2	F6	F^3
E1	0	NC	-	NC	-	NC	-	F8	F^4
-	0	-	-	VCCO (Bank 0)	-	VCCO (Bank 0)	-	VCCO (Bank 0)	-
-	0	GND (Bank 0)	-	GND (Bank 0)	-	GND (Bank 0)	-	GND (Bank 0)	-
F2	0	NC	-	NC	-	NC	-	F10	F^5
F1	0	NC	-	NC	-	D2	D^1	F12	F^6
G1	0	NC	-	NC	-	D0	D^0	F14	F^7
G6	0	NC	-	D14	D^9	F2	F^1	H8	H^2
G4	0	NC	-	D12	D^8	F0	F^0	H12	H^3
H6	0	D14	D^7	D10	D^7	E14	E^7	G14	G^7
G3	0	D12	D^6	D9	D^6	E12	E^6	G12	G^6
H5	0	D10	D^5	D8	D^5	E10	E^5	G10	G^5
G2	0	D8	D^4	D6	D^4	E8	E^4	G8	G^4
H1	0	D6	D^3	D4	D^3	E6	E^3	G6	G^3
H2	0	D4	D^2	D2	D^2	E4	E^2	G4	G^2
H3	0	D2	D^1	D1	D^1	E2	E^1	G2	G^1
H4	0	D0	D^0	D0	D^0	E0	E^0	G0	G^0
-	0	VCCO (Bank 0)	-	VCCO (Bank 0)	-	VCCO (Bank 0)	-	VCCO (Bank 0)	-
-	0	-	-	GND (Bank 0)	-	GND (Bank 0)	-	GND (Bank 0)	-
J4	0	E0	E^0	E0	E^0	H0	H^0	J0	J^0
J3	0	E2	E^1	E1	E^1	H2	H^1	J2	J^1
J2	0	E4	E^2	E2	E^2	H4	H^2	J4	J^2
J1	0	E6	E^3	E4	E^3	H6	H^3	J6	J^3
K1	0	E8	E^4	E6	E^4	H8	H^4	J8	J^4
J5	0	E10	E^5	E8	E^5	H10	H^5	J10	J^5
K2	0	E12	E^6	E9	E^6	H12	H^6	J12	J^6

Ordering Information

Note: ispMACH 4000 devices are all dual marked except the slowest commercial speed grade ispMACH 4000Z devices. For example, the commercial speed grade LC4128C-5T100C is also marked with the industrial grade -75I. The commercial grade is always one speed grade faster than the associated dual mark industrial grade. The slowest commercial speed grade ispMACH 4000Z devices are marked as commercial grade only.

Conventional Packaging

ispMACH 4000ZC (Zero Power, 1.8V) Commercial Devices

Device	Part Number	Macrocells	Voltage	t _{PD}	Package	Pin/Ball Count	I/O	Grade
LC4032ZC	LC4032ZC-35M56C	32	1.8	3.5	csBGA	56	32	C
	LC4032ZC-5M56C	32	1.8	5	csBGA	56	32	C
	LC4032ZC-75M56C	32	1.8	7.5	csBGA	56	32	C
	LC4032ZC-35T48C	32	1.8	3.5	TQFP	48	32	C
	LC4032ZC-5T48C	32	1.8	5	TQFP	48	32	C
	LC4032ZC-75T48C	32	1.8	7.5	TQFP	48	32	C
LC4064ZC	LC4064ZC-37M132C	64	1.8	3.7	csBGA	132	64	C
	LC4064ZC-5M132C	64	1.8	5	csBGA	132	64	C
	LC4064ZC-75M132C	64	1.8	7.5	csBGA	132	64	C
	LC4064ZC-37T100C	64	1.8	3.7	TQFP	100	64	C
	LC4064ZC-5T100C	64	1.8	5	TQFP	100	64	C
	LC4064ZC-75T100C	64	1.8	7.5	TQFP	100	64	C
	LC4064ZC-37M56C	64	1.8	3.7	csBGA	56	32	C
	LC4064ZC-5M56C	64	1.8	5	csBGA	56	32	C
	LC4064ZC-75M56C	64	1.8	7.5	csBGA	56	32	C
	LC4064ZC-37T48C	64	1.8	3.7	TQFP	48	32	C
	LC4064ZC-5T48C	64	1.8	5	TQFP	48	32	C
	LC4064ZC-75T48C	64	1.8	7.5	TQFP	48	32	C
LC4128ZC	LC4128ZC-42M132C	128	1.8	4.2	csBGA	132	96	C
	LC4128ZC-75M132C	128	1.8	7.5	csBGA	132	96	C
	LC4128ZC-42T100C	128	1.8	4.2	TQFP	100	64	C
	LC4128ZC-75T100C	128	1.8	7.5	TQFP	100	64	C
LC4256ZC	LC4256ZC-45T176C	256	1.8	4.5	TQFP	176	128	C
	LC4256ZC-75T176C	256	1.8	7.5	TQFP	176	128	C
	LC4256ZC-45M132C	256	1.8	4.5	csBGA	132	96	C
	LC4256ZC-75M132C	256	1.8	7.5	csBGA	132	96	C
	LC4256ZC-45T100C	256	1.8	4.5	TQFP	100	64	C
	LC4256ZC-75T100C	256	1.8	7.5	TQFP	100	64	C

ispMACH 4000ZC (1.8V, Zero Power) Industrial Devices

Device	Part Number	Macrocells	Voltage	t _{PD}	Package	Pin/Ball Count	I/O	Grade
LC4032ZC	LC4032ZC-5M56I	32	1.8	5	csBGA	56	32	I
	LC4032ZC-75M56I	32	1.8	7.5	csBGA	56	32	I
	LC4032ZC-5T48I	32	1.8	5	TQFP	48	32	I
	LC4032ZC-75T48I	32	1.8	7.5	TQFP	48	32	I

ispMACH 4000B (2.5V) Commercial Devices (Cont.)

Device	Part Number	Macrocells	Voltage	t _{PD}	Package	Pin/Ball Count	I/O	Grade
LC4256B	LC4256B-3FT256AC	256	2.5	3	ftBGA	256	128	C
	LC4256B-5FT256AC	256	2.5	5	ftBGA	256	128	C
	LC4256B-75FT256AC	256	2.5	7.5	ftBGA	256	128	C
	LC4256B-3FT256BC	256	2.5	3	ftBGA	256	160	C
	LC4256B-5FT256BC	256	2.5	5	ftBGA	256	160	C
	LC4256B-75FT256BC	256	2.5	7.5	ftBGA	256	160	C
	LC4256B-3F256AC ¹	256	2.5	3	fpBGA	256	128	C
	LC4256B-5F256AC ¹	256	2.5	5	fpBGA	256	128	C
	LC4256B-75F256AC ¹	256	2.5	7.5	fpBGA	256	128	C
	LC4256B-3F256BC ¹	256	2.5	3	fpBGA	256	160	C
	LC4256B-5F256BC ¹	256	2.5	5	fpBGA	256	160	C
	LC4256B-75F256BC ¹	256	2.5	7.5	fpBGA	256	160	C
	LC4256B-3T176C	256	2.5	3	TQFP	176	128	C
	LC4256B-5T176C	256	2.5	5	TQFP	176	128	C
	LC4256B-75T176C	256	2.5	7.5	TQFP	176	128	C
	LC4256B-3T100C	256	2.5	3	TQFP	100	64	C
LC4256B-5T100C	256	2.5	5	TQFP	100	64	C	
LC4256B-75T100C	256	2.5	7.5	TQFP	100	64	C	
LC4384B	LC4384B-35FT256C	384	2.5	3.5	ftBGA	256	192	C
	LC4384B-5FT256C	384	2.5	5	ftBGA	256	192	C
	LC4384B-75FT256C	384	2.5	7.5	ftBGA	256	192	C
	LC4384B-35F256C ¹	384	2.5	3.5	fpBGA	256	192	C
	LC4384B-5F256C ¹	384	2.5	5	fpBGA	256	192	C
	LC4384B-75F256C ¹	384	2.5	7.5	fpBGA	256	192	C
	LC4384B-35T176C	384	2.5	3.5	TQFP	176	128	C
	LC4384B-5T176C	384	2.5	5	TQFP	176	128	C
	LC4384B-75T176C	384	2.5	7.5	TQFP	176	128	C
LC4512B	LC4512B-35FT256C	512	2.5	3.5	ftBGA	256	208	C
	LC4512B-5FT256C	512	2.5	5	ftBGA	256	208	C
	LC4512B-75FT256C	512	2.5	7.5	ftBGA	256	208	C
	LC4512B-35F256C ¹	512	2.5	3.5	fpBGA	256	208	C
	LC4512B-5F256C ¹	512	2.5	5	fpBGA	256	208	C
	LC4512B-75F256C ¹	512	2.5	7.5	fpBGA	256	208	C
	LC4512B-35T176C	512	2.5	3.5	TQFP	176	128	C
	LC4512B-5T176C	512	2.5	5	TQFP	176	128	C
	LC4512B-75T176C	512	2.5	7.5	TQFP	176	128	C

1. Use ftBGA package. fpBGA package devices have been discontinued via PCN#14A-07.

ispMACH 4000B (2.5V) Industrial Devices (Cont.)

Family	Part Number	Macrocells	Voltage	t _{PD}	Package	Pin/Ball Count	I/O	Grade
LC4384B	LC4384B-5FT256I	384	2.5	5	ftBGA	256	192	I
	LC4384B-75FT256I	384	2.5	7.5	ftBGA	256	192	I
	LC4384B-10FT256I	384	2.5	10	ftBGA	256	192	I
	LC4384B-5F256I ¹	384	2.5	5	fpBGA	256	192	I
	LC4384B-75F256I ¹	384	2.5	7.5	fpBGA	256	192	I
	LC4384B-10F256I ¹	384	2.5	10	fpBGA	256	192	I
	LC4384B-5T176I	384	2.5	5	TQFP	176	128	I
	LC4384B-75T176I	384	2.5	7.5	TQFP	176	128	I
	LC4384B-10T176I	384	2.5	10	TQFP	176	128	I
LC4512B	LC4512B-5FT256I	512	2.5	5	ftBGA	256	208	I
	LC4512B-75FT256I	512	2.5	7.5	ftBGA	256	208	I
	LC4512B-10FT256I	512	2.5	10	ftBGA	256	208	I
	LC4512B-5F256I ¹	512	2.5	5	fpBGA	256	208	I
	LC4512B-75F256I ¹	512	2.5	7.5	fpBGA	256	208	I
	LC4512B-10F256I ¹	512	2.5	10	fpBGA	256	208	I
	LC4512B-5T176I	512	2.5	5	TQFP	176	128	I
	LC4512B-75T176I	512	2.5	7.5	TQFP	176	128	I
	LC4512B-10T176I	512	2.5	10	TQFP	176	128	I

1. Use ftBGA package. fpBGA package devices have been discontinued via PCN#14A-07.

ispMACH 4000V (3.3V) Commercial Devices

Device	Part Number	Macrocells	Voltage	t _{PD}	Package	Pin/Ball Count	I/O	Grade
LC4032V	LC4032V-25T48C	32	3.3	2.5	TQFP	48	32	C
	LC4032V-5T48C	32	3.3	5	TQFP	48	32	C
	LC4032V-75T48C	32	3.3	7.5	TQFP	48	32	C
	LC4032V-25T44C	32	3.3	2.5	TQFP	44	30	C
	LC4032V-5T44C	32	3.3	5	TQFP	44	30	C
	LC4032V-75T44C	32	3.3	7.5	TQFP	44	30	C
LC4064V	LC4064V-25T100C	64	3.3	2.5	TQFP	100	64	C
	LC4064V-5T100C	64	3.3	5	TQFP	100	64	C
	LC4064V-75T100C	64	3.3	7.5	TQFP	100	64	C
	LC4064V-25T48C	64	3.3	2.5	TQFP	48	32	C
	LC4064V-5T48C	64	3.3	5	TQFP	48	32	C
	LC4064V-75T48C	64	3.3	7.5	TQFP	48	32	C
	LC4064V-25T44C	64	3.3	2.5	TQFP	44	30	C
	LC4064V-5T44C	64	3.3	5	TQFP	44	30	C
LC4064V-75T44C	64	3.3	7.5	TQFP	44	30	C	

ispMACH 4000B (2.5V) Lead-Free Commercial Devices (Cont.)

Device	Part Number	Macrocells	Voltage	t _{PD}	Package	Pin/Ball Count	I/O	Grade
LC4384B	LC4384B-35FTN256C	384	2.5	3.5	Lead-Free ftBGA	256	192	C
	LC4384B-5FTN256C	384	2.5	5	Lead-Free ftBGA	256	192	C
	LC4384B-75FTN256C	384	2.5	7.5	Lead-Free ftBGA	256	192	C
	LC4384B-35FN256C ¹	384	2.5	3.5	Lead-Free fpBGA	256	192	C
	LC4384B-5FN256C ¹	384	2.5	5	Lead-Free fpBGA	256	192	C
	LC4384B-75FN256C ¹	384	2.5	7.5	Lead-Free fpBGA	256	192	C
	LC4384B-35TN176C	384	2.5	3.5	Lead-Free TQFP	176	128	C
	LC4384B-5TN176C	384	2.5	5	Lead-Free TQFP	176	128	C
LC4512B	LC4512B-35FTN256C	512	2.5	3.5	Lead-Free ftBGA	256	208	C
	LC4512B-5FTN256C	512	2.5	5	Lead-Free ftBGA	256	208	C
	LC4512B-75FTN256C	512	2.5	7.5	Lead-Free ftBGA	256	208	C
	LC4512B-35FN256C ¹	512	2.5	3.5	Lead-Free fpBGA	256	208	C
	LC4512B-5FN256C ¹	512	2.5	5	Lead-Free fpBGA	256	208	C
	LC4512B-75FN256C ¹	512	2.5	7.5	Lead-Free fpBGA	256	208	C
	LC4512B-35TN176C	512	2.5	3.5	Lead-Free TQFP	176	128	C
	LC4512B-5TN176C	512	2.5	5	Lead-Free TQFP	176	128	C
	LC4512B-75TN176C	512	2.5	7.5	Lead-Free TQFP	176	128	C

1. Use ftBGA package. fpBGA package devices have been discontinued via PCN#14A-07.

ispMACH 4000B (2.5V) Lead-Free Industrial Devices

Device	Part Number	Macrocells	Voltage	t _{PD}	Package	Pin/Ball Count	I/O	Grade
LC4032B	LC4032B-5TN48I	32	2.5	5	Lead-Free TQFP	48	32	I
	LC4032B-75TN48I	32	2.5	7.5	Lead-Free TQFP	48	32	I
	LC4032B-10TN48I	32	2.5	10	Lead-Free TQFP	48	32	I
	LC4032B-5TN44I	32	2.5	5	Lead-Free TQFP	44	30	I
	LC4032B-75TN44I	32	2.5	7.5	Lead-Free TQFP	44	30	I
	LC4032B-10TN44I	32	2.5	10	Lead-Free TQFP	44	30	I
LC4064B	LC4064B-5TN100I	64	2.5	5	Lead-Free TQFP	100	64	I
	LC4064B-75TN100I	64	2.5	7.5	Lead-Free TQFP	100	64	I
	LC4064B-10TN100I	64	2.5	10	Lead-Free TQFP	100	64	I
	LC4064B-5TN48I	64	2.5	5	Lead-Free TQFP	48	32	I
	LC4064B-75TN48I	64	2.5	7.5	Lead-Free TQFP	48	32	I
	LC4064B-10TN48I	64	2.5	10	Lead-Free TQFP	48	32	I
	LC4064B-5TN44I	64	2.5	5	Lead-Free TQFP	44	30	I
	LC4064B-75TN44I	64	2.5	7.5	Lead-Free TQFP	44	30	I
	LC4064B-10TN44I	64	2.5	10	Lead-Free TQFP	44	30	I

ispMACH 4000V (3.3V) Lead-Free Industrial Devices

Device	Part Number	Macrocells	Voltage	t _{PD}	Package	Pin/Ball Count	I/O	Grade
LC4032V	LC4032V-5TN48I	32	3.3	5	Lead-free TQFP	48	32	I
	LC4032V-75TN48I	32	3.3	7.5	Lead-free TQFP	48	32	I
	LC4032V-10TN48I	32	3.3	10	Lead-free TQFP	48	32	I
	LC4032V-5TN44I	32	3.3	5	Lead-free TQFP	44	30	I
	LC4032V-75TN44I	32	3.3	7.5	Lead-free TQFP	44	30	I
	LC4032V-10TN44I	32	3.3	10	Lead-free TQFP	44	30	I
LC4064V	LC4064V-5TN100I	64	3.3	5	Lead-free TQFP	100	64	I
	LC4064V-75TN100I	64	3.3	7.5	Lead-free TQFP	100	64	I
	LC4064V-10TN100I	64	3.3	10	Lead-free TQFP	100	64	I
	LC4064V-5TN48I	64	3.3	5	Lead-free TQFP	48	32	I
	LC4064V-75TN48I	64	3.3	7.5	Lead-free TQFP	48	32	I
	LC4064V-10TN48I	64	3.3	10	Lead-free TQFP	48	32	I
	LC4064V-5TN44I	64	3.3	5	Lead-free TQFP	44	30	I
	LC4064V-75TN44I	64	3.3	7.5	Lead-free TQFP	44	30	I
LC4128V	LC4128V-5TN144I	128	3.3	5	Lead-free TQFP	144	96	I
	LC4128V-75TN144I	128	3.3	7.5	Lead-free TQFP	144	96	I
	LC4128V-10TN144I	128	3.3	10	Lead-free TQFP	144	96	I
	LC4128V-5TN128I	128	3.3	5	Lead-free TQFP	128	92	I
	LC4128V-75TN128I	128	3.3	7.5	Lead-free TQFP	128	92	I
	LC4128V-10TN128I	128	3.3	10	Lead-free TQFP	128	92	I
	LC4128V-5TN100I	128	3.3	5	Lead-free TQFP	100	64	I
	LC4128V-75TN100I	128	3.3	7.5	Lead-free TQFP	100	64	I
	LC4128V-10TN100I	128	3.3	10	Lead-free TQFP	100	64	I