



Welcome to [E-XFL.COM](http://E-XFL.COM)

## Understanding **Embedded - CPLDs (Complex Programmable Logic Devices)**

Embedded - CPLDs, or Complex Programmable Logic Devices, are highly versatile digital logic devices used in electronic systems. These programmable components are designed to perform complex logical operations and can be customized for specific applications. Unlike fixed-function ICs, CPLDs offer the flexibility to reprogram their configuration, making them an ideal choice for various embedded systems. They consist of a set of logic gates and programmable interconnects, allowing designers to implement complex logic circuits without needing custom hardware.

## Applications of Embedded - CPLDs

### Details

Product Status	Active
Programmable Type	In System Programmable
Delay Time tpd(1) Max	10 ns
Voltage Supply - Internal	3V ~ 3.6V
Number of Logic Elements/Blocks	8
Number of Macrocells	128
Number of Gates	-
Number of I/O	64
Operating Temperature	-40°C ~ 105°C (TJ)
Mounting Type	Surface Mount
Package / Case	100-LQFP
Supplier Device Package	100-TQFP (14x14)
Purchase URL	<a href="https://www.e-xfl.com/product-detail/lattice-semiconductor/lc4128v-10tn100i">https://www.e-xfl.com/product-detail/lattice-semiconductor/lc4128v-10tn100i</a>

Figure 2. Generic Logic Block

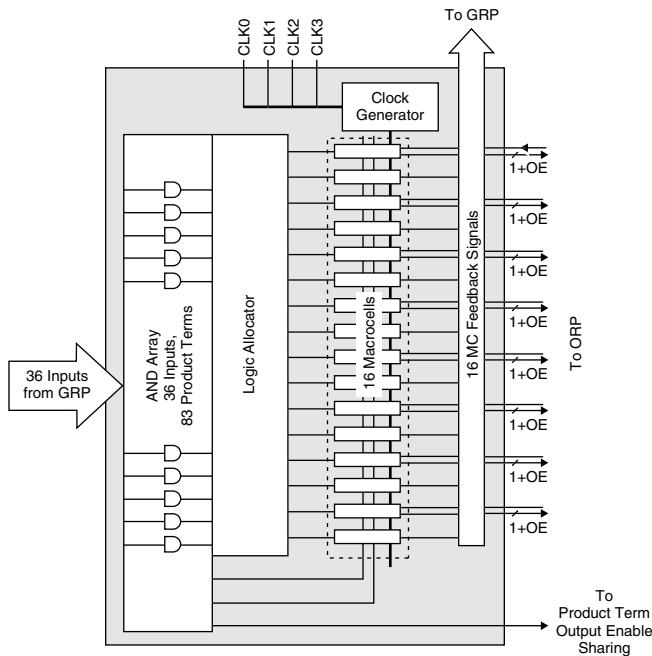

**AND Array**

The programmable AND Array consists of 36 inputs and 83 output product terms. The 36 inputs from the GRP are used to form 72 lines in the AND Array (true and complement of the inputs). Each line in the array can be connected to any of the 83 output product terms via a wired-AND. Each of the 80 logic product terms feed the logic allocator with the remaining three control product terms feeding the Shared PT Clock, Shared PT Initialization and Shared PT OE. The Shared PT Clock and Shared PT Initialization signals can optionally be inverted before being fed to the macrocells.

Every set of five product terms from the 80 logic product terms forms a product term cluster starting with PT0. There is one product term cluster for every macrocell in the GLB. Figure 3 is a graphical representation of the AND Array.

## I/O Recommended Operating Conditions

Standard	$V_{CCO}$ (V) <sup>1</sup>	
	Min.	Max.
LVTTTL	3.0	3.6
LVC MOS 3.3	3.0	3.6
Extended LVC MOS 3.3 <sup>2</sup>	2.7	3.6
LVC MOS 2.5	2.3	2.7
LVC MOS 1.8	1.65	1.95
PCI 3.3	3.0	3.6

1. Typical values for  $V_{CCO}$  are the average of the min. and max. values.

2. ispMACH 4000Z only.

## DC Electrical Characteristics

### Over Recommended Operating Conditions

Symbol	Parameter	Condition	Min.	Typ.	Max.	Units
$I_{IL}, I_{IH}^{1,4}$	Input Leakage Current (ispMACH 4000Z)	$0 \leq V_{IN} < V_{CCO}$	—	0.5	1	$\mu A$
$I_{IH}^1$	Input High Leakage Current (ispMACH 4000Z)	$V_{CCO} < V_{IN} \leq 5.5V$	—	—	10	$\mu A$
$I_{IL}, I_{IH}^1$	Input Leakage Current (ispMACH 4000V/B/C)	$0 \leq V_{IN} \leq 3.6V, T_j = 105^\circ C$	—	—	10	$\mu A$
		$0 \leq V_{IN} \leq 3.6V, T_j = 130^\circ C$	—	—	15	$\mu A$
$I_{IH}^{1,2}$	Input High Leakage Current (ispMACH 4000V/B/C)	$3.6V < V_{IN} \leq 5.5V, T_j = 105^\circ C$ $3.0V \leq V_{CCO} \leq 3.6V$	—	—	20	$\mu A$
		$3.6V < V_{IN} \leq 5.5V, T_j = 130^\circ C$ $3.0V \leq V_{CCO} \leq 3.6V$	—	—	50	$\mu A$
$I_{PU}$	I/O Weak Pull-up Resistor Current (ispMACH 4000Z)	$0 \leq V_{IN} \leq 0.7V_{CCO}$	-30	—	-150	$\mu A$
	I/O Weak Pull-up Resistor Current (ispMACH 4000V/B/C)	$0 \leq V_{IN} \leq 0.7V_{CCO}$	-30	—	-200	$\mu A$
$I_{PD}$	I/O Weak Pull-down Resistor Current	$V_{IL} (MAX) \leq V_{IN} \leq V_{IH} (MIN)$	30	—	150	$\mu A$
$I_{BHLS}$	Bus Hold Low Sustaining Current	$V_{IN} = V_{IL} (MAX)$	30	—	—	$\mu A$
$I_{BHHS}$	Bus Hold High Sustaining Current	$V_{IN} = 0.7 V_{CCO}$	-30	—	—	$\mu A$
$I_{BHLO}$	Bus Hold Low Overdrive Current	$0V \leq V_{IN} \leq V_{BHT}$	—	—	150	$\mu A$
$I_{BHHO}$	Bus Hold High Overdrive Current	$V_{BHT} \leq V_{IN} \leq V_{CCO}$	—	—	-150	$\mu A$
$V_{BHT}$	Bus Hold Trip Points	—	$V_{CCO} * 0.35$	—	$V_{CCO} * 0.65$	V
$C_1$	I/O Capacitance <sup>3</sup>	$V_{CCO} = 3.3V, 2.5V, 1.8V$	—	8	—	pf
		$V_{CC} = 1.8V, V_{IO} = 0$ to $V_{IH} (MAX)$	—		—	
$C_2$	Clock Capacitance <sup>3</sup>	$V_{CCO} = 3.3V, 2.5V, 1.8V$	—	6	—	pf
		$V_{CC} = 1.8V, V_{IO} = 0$ to $V_{IH} (MAX)$	—		—	
$C_3$	Global Input Capacitance <sup>3</sup>	$V_{CCO} = 3.3V, 2.5V, 1.8V$	—	6	—	pf
		$V_{CC} = 1.8V, V_{IO} = 0$ to $V_{IH} (MAX)$	—		—	

1. Input or I/O leakage current is measured with the pin configured as an input or as an I/O with the output driver tristated. It is not measured with the output driver active. Bus maintenance circuits are disabled.

2. 5V tolerant inputs and I/O should only be placed in banks where  $3.0V \leq V_{CCO} \leq 3.6V$ .

3.  $T_A = 25^\circ C, f = 1.0MHz$

4.  $I_{IH}$  excursions of up to 1.5 $\mu A$  maximum per pin above the spec limit may be observed for certain voltage conditions on no more than 10% of the device's I/O pins.

## Supply Current, ispMACH 4000V/B/C

## Over Recommended Operating Conditions

Symbol	Parameter	Condition	Min.	Typ.	Max.	Units
<b>ispMACH 4032V/B/C</b>						
ICC <sup>1,2,3</sup>	Operating Power Supply Current	V <sub>CC</sub> = 3.3V	—	11.8	—	mA
		V <sub>CC</sub> = 2.5V	—	11.8	—	mA
		V <sub>CC</sub> = 1.8V	—	1.8	—	mA
ICC <sup>4</sup>	Standby Power Supply Current	V <sub>CC</sub> = 3.3V	—	11.3	—	mA
		V <sub>CC</sub> = 2.5V	—	11.3	—	mA
		V <sub>CC</sub> = 1.8V	—	1.3	—	mA
<b>ispMACH 4064V/B/C</b>						
ICC <sup>1,2,3</sup>	Operating Power Supply Current	V <sub>CC</sub> = 3.3V	—	12	—	mA
		V <sub>CC</sub> = 2.5V	—	12	—	mA
		V <sub>CC</sub> = 1.8V	—	2	—	mA
ICC <sup>5</sup>	Standby Power Supply Current	V <sub>CC</sub> = 3.3V	—	11.5	—	mA
		V <sub>CC</sub> = 2.5V	—	11.5	—	mA
		V <sub>CC</sub> = 1.8V	—	1.5	—	mA
<b>ispMACH 4128V/B/C</b>						
ICC <sup>1,2,3</sup>	Operating Power Supply Current	V <sub>CC</sub> = 3.3V	—	12	—	mA
		V <sub>CC</sub> = 2.5V	—	12	—	mA
		V <sub>CC</sub> = 1.8V	—	2	—	mA
ICC <sup>4</sup>	Standby Power Supply Current	V <sub>CC</sub> = 3.3V	—	11.5	—	mA
		V <sub>CC</sub> = 2.5V	—	11.5	—	mA
		V <sub>CC</sub> = 1.8V	—	1.5	—	mA
<b>ispMACH 4256V/B/C</b>						
I <sub>CC</sub> <sup>1,2,3</sup>	Operating Power Supply Current	V <sub>CC</sub> = 3.3V	—	12.5	—	mA
		V <sub>CC</sub> = 2.5V	—	12.5	—	mA
		V <sub>CC</sub> = 1.8V	—	2.5	—	mA
I <sub>CC</sub> <sup>4</sup>	Standby Power Supply Current	V <sub>CC</sub> = 3.3V	—	12	—	mA
		V <sub>CC</sub> = 2.5V	—	12	—	mA
		V <sub>CC</sub> = 1.8V	—	2	—	mA
<b>ispMACH 4384V/B/C</b>						
I <sub>CC</sub> <sup>1,2,3</sup>	Operating Power Supply Current	V <sub>CC</sub> = 3.3V	—	13.5	—	mA
		V <sub>CC</sub> = 2.5V	—	13.5	—	mA
		V <sub>CC</sub> = 1.8V	—	3.5	—	mA
I <sub>CC</sub> <sup>4</sup>	Standby Power Supply Current	V <sub>CC</sub> = 3.3V	—	12.5	—	mA
		V <sub>CC</sub> = 2.5V	—	12.5	—	mA
		V <sub>CC</sub> = 1.8V	—	2.5	—	mA
<b>ispMACH 4512V/B/C</b>						
I <sub>CC</sub> <sup>1,2,3</sup>	Operating Power Supply Current	V <sub>CC</sub> = 3.3V	—	14	—	mA
		V <sub>CC</sub> = 2.5V	—	14	—	mA
		V <sub>CC</sub> = 1.8V	—	4	—	mA



## ispMACH 4000V/B/C External Switching Characteristics

Over Recommended Operating Conditions

Parameter	Description <sup>1, 2, 3</sup>	-25		-27		-3		-35		Units
		Min.	Max.	Min.	Max.	Min.	Max.	Min.	Max.	
t <sub>PD</sub>	5-PT bypass combinatorial propagation delay	—	2.5	—	2.7	—	3.0	—	3.5	ns
t <sub>PD_MC</sub>	20-PT combinatorial propagation delay through macrocell	—	3.2	—	3.5	—	3.8	—	4.2	ns
t <sub>S</sub>	GLB register setup time before clock	1.8	—	1.8	—	2.0	—	2.0	—	ns
t <sub>ST</sub>	GLB register setup time before clock with T-type register	2.0	—	2.0	—	2.2	—	2.2	—	ns
t <sub>SIR</sub>	GLB register setup time before clock, input register path	0.7	—	1.0	—	1.0	—	1.0	—	ns
t <sub>SIRZ</sub>	GLB register setup time before clock with zero hold	1.7	—	2.0	—	2.0	—	2.0	—	ns
t <sub>H</sub>	GLB register hold time after clock	0.0	—	0.0	—	0.0	—	0.0	—	ns
t <sub>HT</sub>	GLB register hold time after clock with T-type register	0.0	—	0.0	—	0.0	—	0.0	—	ns
t <sub>HIR</sub>	GLB register hold time after clock, input register path	0.9	—	1.0	—	1.0	—	1.0	—	ns
t <sub>HIRZ</sub>	GLB register hold time after clock, input register path with zero hold	0.0	—	0.0	—	0.0	—	0.0	—	ns
t <sub>CO</sub>	GLB register clock-to-output delay	—	2.2	—	2.7	—	2.7	—	2.7	ns
t <sub>R</sub>	External reset pin to output delay	—	3.5	—	4.0	—	4.4	—	4.5	ns
t <sub>RW</sub>	External reset pulse duration	1.5	—	1.5	—	1.5	—	1.5	-	ns
t <sub>P<sub>TOE/DIS</sub></sub>	Input to output local product term output enable/disable	—	4.0	—	4.5	—	5.0	—	5.5	ns
t <sub>G<sub>P<sub>TOE/DIS</sub></sub></sub>	Input to output global product term output enable/disable	—	5.0	—	6.5	—	8.0	—	8.0	ns
t <sub>G<sub>OE/DIS</sub></sub>	Global OE input to output enable/disable	—	3.0	—	3.5	—	4.0	—	4.5	ns
t <sub>CW</sub>	Global clock width, high or low	1.1	—	1.3	—	1.3	—	1.3	—	ns
t <sub>GW</sub>	Global gate width low (for low transparent) or high (for high transparent)	1.1	—	1.3	—	1.3	—	1.3	—	ns
t <sub>WIR</sub>	Input register clock width, high or low	1.1	—	1.3	—	1.3	—	1.3	—	ns
f <sub>MAX</sub> <sup>4</sup>	Clock frequency with internal feedback	—	400	—	333	—	322	—	322	MHz
f <sub>MAX</sub> (Ext.)	Clock frequency with external feedback, [1/ (t <sub>S</sub> + t <sub>CO</sub> )]	—	250	—	222	—	212	—	212	MHz

1. Timing numbers are based on default LVCMOS 1.8 I/O buffers. Use timing adjusters provided to calculate other standards.

Timing v.3.2

2. Measured using standard switching circuit, assuming GRP loading of 1 and 1 output switching.

3. Pulse widths and clock widths less than minimum will cause unknown behavior.

4. Standard 16-bit counter using GRP feedback.

**ispMACH 4000V/B/C Timing Adders<sup>1</sup> (Cont.)**

Adder Type	Base Parameter	Description	-5		-75		-10		Units
			Min.	Max.	Min.	Max.	Min.	Max.	
<b>Optional Delay Adders</b>									
t <sub>INDIO</sub>	t <sub>INREG</sub>	Input register delay	—	1.00	—	1.00	—	1.00	ns
t <sub>EXP</sub>	t <sub>MCELL</sub>	Product term expander delay	—	0.33	—	0.33	—	0.33	ns
t <sub>ORP</sub>	—	Output routing pool delay	—	0.05	—	0.05	—	0.05	ns
t <sub>BLA</sub>	t <sub>ROUTE</sub>	Additional block loading adder	—	0.05	—	0.05	—	0.05	ns
<b>t<sub>IOI</sub> Input Adjusters</b>									
LVTTTL_in	t <sub>IN</sub> , t <sub>GCLK_IN</sub> , t <sub>GOE</sub>	Using LVTTTL standard	—	0.60	—	0.60	—	0.60	ns
LVC MOS33_in	t <sub>IN</sub> , t <sub>GCLK_IN</sub> , t <sub>GOE</sub>	Using LVC MOS 3.3 standard	—	0.60	—	0.60	—	0.60	ns
LVC MOS25_in	t <sub>IN</sub> , t <sub>GCLK_IN</sub> , t <sub>GOE</sub>	Using LVC MOS 2.5 standard	—	0.60	—	0.60	—	0.60	ns
LVC MOS18_in	t <sub>IN</sub> , t <sub>GCLK_IN</sub> , t <sub>GOE</sub>	Using LVC MOS 1.8 standard	—	0.00	—	0.00	—	0.00	ns
PCI_in	t <sub>IN</sub> , t <sub>GCLK_IN</sub> , t <sub>GOE</sub>	Using PCI compatible input	—	0.60	—	0.60	—	0.60	ns
<b>t<sub>IOO</sub> Output Adjusters</b>									
LVTTTL_out	t <sub>BUF</sub> , t <sub>EN</sub> , t <sub>DIS</sub>	Output configured as TTL buffer	—	0.20	—	0.20	—	0.20	ns
LVC MOS33_out	t <sub>BUF</sub> , t <sub>EN</sub> , t <sub>DIS</sub>	Output configured as 3.3V buffer	—	0.20	—	0.20	—	0.20	ns
LVC MOS25_out	t <sub>BUF</sub> , t <sub>EN</sub> , t <sub>DIS</sub>	Output configured as 2.5V buffer	—	0.10	—	0.10	—	0.10	ns
LVC MOS18_out	t <sub>BUF</sub> , t <sub>EN</sub> , t <sub>DIS</sub>	Output configured as 1.8V buffer	—	0.00	—	0.00	—	0.00	ns
PCI_out	t <sub>BUF</sub> , t <sub>EN</sub> , t <sub>DIS</sub>	Output configured as PCI compatible buffer	—	0.20	—	0.20	—	0.20	ns
Slow Slew	t <sub>BUF</sub> , t <sub>EN</sub>	Output configured for slow slew rate	—	1.00	—	1.00	—	1.00	ns

Note: Open drain timing is the same as corresponding LVC MOS timing.

Timing v.3.2

1. Refer to TN1004, [ispMACH 4000 Timing Model Design and Usage Guidelines](#) for information regarding use of these adders.

ispMACH 4000Z Timing Adders (Cont.)<sup>1</sup>

Adder Type	Base Parameter	Description	-45		-5		-75		Units
			Min.	Max.	Min.	Max.	Min.	Max.	
<b>Optional Delay Adders</b>									
t <sub>INDIO</sub>	t <sub>INREG</sub>	Input register delay	—	1.30	—	1.30	—	1.30	ns
t <sub>EXP</sub>	t <sub>MCELL</sub>	Product term expander delay	—	0.45	—	0.45	—	0.50	ns
t <sub>ORP</sub>	—	Output routing pool delay	—	0.40	—	0.40	—	0.40	ns
t <sub>BLA</sub>	t <sub>ROUTE</sub>	Additional block loading adder	—	0.05	—	0.05	—	0.05	ns
<b>t<sub>IOI</sub> Input Adjusters</b>									
LVTTTL_in	t <sub>IN</sub> , t <sub>GCLK_IN</sub> , t <sub>GOE</sub>	Using LVTTTL standard	—	0.60	—	0.60	—	0.60	ns
LVC MOS33_in	t <sub>IN</sub> , t <sub>GCLK_IN</sub> , t <sub>GOE</sub>	Using LVC MOS 3.3 standard	—	0.60	—	0.60	—	0.60	ns
LVC MOS25_in	t <sub>IN</sub> , t <sub>GCLK_IN</sub> , t <sub>GOE</sub>	Using LVC MOS 2.5 standard	—	0.60	—	0.60	—	0.60	ns
LVC MOS18_in	t <sub>IN</sub> , t <sub>GCLK_IN</sub> , t <sub>GOE</sub>	Using LVC MOS 1.8 standard	—	0.00	—	0.00	—	0.00	ns
PCI_in	t <sub>IN</sub> , t <sub>GCLK_IN</sub> , t <sub>GOE</sub>	Using PCI compatible input	—	0.60	—	0.60	—	0.60	ns
<b>t<sub>IOO</sub> Output Adjusters</b>									
LVTTTL_out	t <sub>BUF</sub> , t <sub>EN</sub> , t <sub>DIS</sub>	Output configured as TTL buffer	—	0.20	—	0.20	—	0.20	ns
LVC MOS33_out	t <sub>BUF</sub> , t <sub>EN</sub> , t <sub>DIS</sub>	Output configured as 3.3V buffer	—	0.20	—	0.20	—	0.20	ns
LVC MOS25_out	t <sub>BUF</sub> , t <sub>EN</sub> , t <sub>DIS</sub>	Output configured as 2.5V buffer	—	0.10	—	0.10	—	0.10	ns
LVC MOS18_out	t <sub>BUF</sub> , t <sub>EN</sub> , t <sub>DIS</sub>	Output configured as 1.8V buffer	—	0.00	—	0.00	—	0.00	ns
PCI_out	t <sub>BUF</sub> , t <sub>EN</sub> , t <sub>DIS</sub>	Output configured as PCI compatible buffer	—	0.20	—	0.20	—	0.20	ns
Slow Slew	t <sub>BUF</sub> , t <sub>EN</sub>	Output configured for slow slew rate	—	1.00	—	1.00	—	1.00	ns

Note: Open drain timing is the same as corresponding LVC MOS timing.

Timing v.2.2

1. Refer to TN1004, [ispMACH 4000 Timing Model Design and Usage Guidelines](#) for information regarding use of these adders.



---

**Boundary Scan Waveforms and Timing Specifications**

Symbol	Parameter	Min.	Max.	Units
$t_{\text{BTCP}}$	TCK [BSCAN test] clock cycle	40	—	ns
$t_{\text{BTCH}}$	TCK [BSCAN test] pulse width high	20	—	ns
$t_{\text{BTCL}}$	TCK [BSCAN test] pulse width low	20	—	ns
$t_{\text{BTSU}}$	TCK [BSCAN test] setup time	8	—	ns
$t_{\text{BTH}}$	TCK [BSCAN test] hold time	10	—	ns
$t_{\text{BRF}}$	TCK [BSCAN test] rise and fall time	50	—	mV/ns
$t_{\text{BTCO}}$	TAP controller falling edge of clock to valid output	—	10	ns
$t_{\text{BTOZ}}$	TAP controller falling edge of clock to data output disable	—	10	ns
$t_{\text{BTVO}}$	TAP controller falling edge of clock to data output enable	—	10	ns
$t_{\text{BTCPSU}}$	BSCAN test Capture register setup time	8	—	ns
$t_{\text{BTCPH}}$	BSCAN test Capture register hold time	10	—	ns
$t_{\text{BTUCO}}$	BSCAN test Update reg, falling edge of clock to valid output	—	25	ns
$t_{\text{BTUOZ}}$	BSCAN test Update reg, falling edge of clock to output disable	—	25	ns
$t_{\text{BTUOV}}$	BSCAN test Update reg, falling edge of clock to output enable	—	25	ns

### Switching Test Conditions

Figure 12 shows the output test load that is used for AC testing. The specific values for resistance, capacitance, voltage, and other test conditions are shown in Table 11.

**Figure 12. Output Test Load, LVTTTL and LVCMOS Standards**

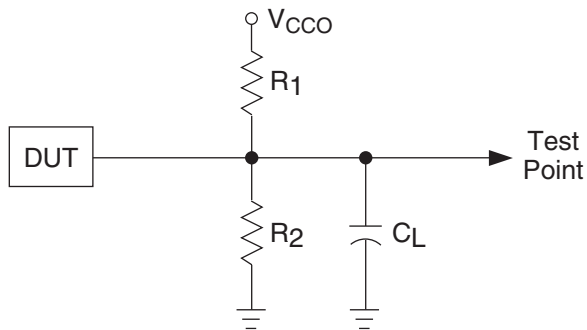

0213A/ispM4k

**Table 11. Test Fixture Required Components**

Test Condition	R <sub>1</sub>	R <sub>2</sub>	C <sub>L</sub> <sup>1</sup>	Timing Ref.	V <sub>CCO</sub>
LVCMOS I/O, (L -> H, H -> L)	106Ω	106Ω	35pF	LVCMOS 3.3 = 1.5V	LVCMOS 3.3 = 3.0V
				LVCMOS 2.5 = V <sub>CCO</sub> /2	LVCMOS 2.5 = 2.3V
				LVCMOS 1.8 = V <sub>CCO</sub> /2	LVCMOS 1.8 = 1.65V
LVCMOS I/O (Z -> H)	∞	106Ω	35pF	1.5V	3.0V
LVCMOS I/O (Z -> L)	106Ω	∞	35pF	1.5V	3.0V
LVCMOS I/O (H -> Z)	∞	106Ω	5pF	V <sub>OH</sub> - 0.3	3.0V
LVCMOS I/O (L -> Z)	106Ω	∞	5pF	V <sub>OL</sub> + 0.3	3.0V

1. C<sub>L</sub> includes test fixtures and probe capacitance.

**ispMACH 4032V/B/C/Z and 4064V/B/C/Z Logic Signal Connections:  
48-Pin TQFP (Cont.)**

Pin Number	Bank Number	ispMACH 4032V/B/C/Z		ispMACH 4064V/B/C		ispMACH 4064Z	
		GLB/MC/Pad	ORP	GLB/MC/Pad	ORP	GLB/MC/Pad	ORP
33	1	B10	B <sup>^</sup> 10	D4	D <sup>^</sup> 2	D10	D <sup>^</sup> 5
34	1	B11	B <sup>^</sup> 11	D6	D <sup>^</sup> 3	D8	D <sup>^</sup> 4
35	-	TDO	-	TDO	-	TDO	-
36	-	VCC	-	VCC	-	VCC	-
37	-	GND	-	GND	-	GND	-
38	1	B12	B <sup>^</sup> 12	D8	D <sup>^</sup> 4	D6	D <sup>^</sup> 3
39	1	B13	B <sup>^</sup> 13	D10	D <sup>^</sup> 5	D4	D <sup>^</sup> 2
40	1	B14	B <sup>^</sup> 14	D12	D <sup>^</sup> 6	D2	D <sup>^</sup> 1
41	1	B15/GOE1	B <sup>^</sup> 15	D14/GOE1	D <sup>^</sup> 7	D0/GOE1	D <sup>^</sup> 0
42	1	CLK3/I	-	CLK3/I	-	CLK3/I	-
43	0	CLK0/I	-	CLK0/I	-	CLK0/I	-
44	0	A0/GOE0	A <sup>^</sup> 0	A0/GOE0	A <sup>^</sup> 0	A0/GOE0	A <sup>^</sup> 0
45	0	A1	A <sup>^</sup> 1	A2	A <sup>^</sup> 1	A1	A <sup>^</sup> 1
46	0	A2	A <sup>^</sup> 2	A4	A <sup>^</sup> 2	A2	A <sup>^</sup> 2
47	0	A3	A <sup>^</sup> 3	A6	A <sup>^</sup> 3	A4	A <sup>^</sup> 3
48	0	A4	A <sup>^</sup> 4	A8	A <sup>^</sup> 4	A6	A <sup>^</sup> 4

**ispMACH 4032Z and 4064Z Logic Signal Connections: 56-Ball csBGA**

Ball Number	Bank Number	ispMACH 4032Z		ispMACH 4064Z	
		GLB/MC/Pad	ORP	GLB/MC/Pad	ORP
B1	-	TDI	-	TDI	-
C3	0	A5	A <sup>^</sup> 5	A8	A <sup>^</sup> 5
C1	0	A6	A <sup>^</sup> 6	A10	A <sup>^</sup> 6
D1	0	A7	A <sup>^</sup> 7	A11	A <sup>^</sup> 7
D3	0	GND (Bank 0)	-	GND (Bank 0)	-
E3	0	NC <sup>1</sup>	-	I <sup>1</sup>	-
E1	0	NC <sup>1</sup>	-	I <sup>1</sup>	-
F3	0	VCCO (Bank 0)	-	VCCO (Bank 0)	-
F1	0	A8	A <sup>^</sup> 8	B15	B <sup>^</sup> 7
G3	0	A9	A <sup>^</sup> 9	B12	B <sup>^</sup> 6
G1	0	A10	A <sup>^</sup> 10	B10	B <sup>^</sup> 5
H1	0	A11	A <sup>^</sup> 11	B8	B <sup>^</sup> 4
J1	0	NC	-	I	-
K1	-	TCK	-	TCK	-
K2	-	VCC	-	VCC	-
H3	-	GND	-	GND	-
K3	-	NC <sup>1</sup>	-	I <sup>1</sup>	-
K4	0	A12	A <sup>^</sup> 12	B6	B <sup>^</sup> 3
H4	0	A13	A <sup>^</sup> 13	B4	B <sup>^</sup> 2
H5	0	A14	A <sup>^</sup> 14	B2	B <sup>^</sup> 1

**ispMACH 4032Z and 4064Z Logic Signal Connections: 56-Ball csBGA (Cont.)**

Ball Number	Bank Number	ispMACH 4032Z		ispMACH 4064Z	
		GLB/MC/Pad	ORP	GLB/MC/Pad	ORP
K5	0	A15	A <sup>15</sup>	B0	B <sup>0</sup>
H6	0	CLK1/I	-	CLK1/I	-
K6	1	CLK2/I	-	CLK2/I	-
H7	1	B0	B <sup>0</sup>	C0	C <sup>0</sup>
K7	1	B1	B <sup>1</sup>	C1	C <sup>1</sup>
K8	1	B2	B <sup>2</sup>	C2	C <sup>2</sup>
K9	1	B3	B <sup>3</sup>	C4	C <sup>3</sup>
K10	1	B4	B <sup>4</sup>	C6	C <sup>4</sup>
J10	-	TMS	-	TMS	-
H8	1	B5	B <sup>5</sup>	C8	C <sup>5</sup>
H10	1	B6	B <sup>6</sup>	C10	C <sup>6</sup>
G10	1	B7	B <sup>7</sup>	C11	C <sup>7</sup>
G8	1	GND (Bank 1)	-	GND (Bank 1)	-
F8	1	NC <sup>1</sup>	-	I <sup>1</sup>	-
F10	1	NC <sup>1</sup>	-	I <sup>1</sup>	-
E8	1	VCCO (Bank 1)	-	VCCO (Bank 1)	-
E10	1	B8	B <sup>8</sup>	D15	D <sup>7</sup>
D8	1	B9	B <sup>9</sup>	D12	D <sup>6</sup>
D10	1	B10	B <sup>10</sup>	D10	D <sup>5</sup>
C10	1	B11	B <sup>11</sup>	D8	D <sup>4</sup>
B10	1	NC <sup>1</sup>	-	I <sup>1</sup>	-
A10	-	TDO	-	TDO	-
A9	-	VCC	-	VCC	-
C8	-	GND	-	GND	-
A8	1	NC <sup>1</sup>	-	I <sup>1</sup>	-
A7	1	B12	B <sup>12</sup>	D6	D <sup>3</sup>
C7	1	B13	B <sup>13</sup>	D4	D <sup>2</sup>
C6	1	B14	B <sup>14</sup>	D2	D <sup>1</sup>
A6	1	B15/GOE1	B <sup>15</sup>	D0/GOE1	D <sup>0</sup>
C5	1	CLK3/I	-	CLK3/I	-
A5	0	CLK0/I	-	CLK0/I	-
C4	0	A0/GOE0	A <sup>0</sup>	A0/GOE0	A <sup>0</sup>
A4	0	A1	A <sup>1</sup>	A1	A <sup>1</sup>
A3	0	A2	A <sup>2</sup>	A2	A <sup>2</sup>
A2	0	A3	A <sup>3</sup>	A4	A <sup>3</sup>
A1	0	A4	A <sup>4</sup>	A6	A <sup>4</sup>

1. For device migration considerations, these NC pins are input signal pins in ispMACH 4064Z devices.

**ispMACH 4064Z, 4128Z and 4256Z Logic Signal Connections:  
132-Ball csBGA (Cont.)**

Ball Number	Bank Number	ispMACH 4064Z		ispMACH 4128Z		ispMACH 4256Z	
		GLB/MC/Pad	ORP	GLB/MC/Pad	ORP	GLB/MC/Pad	ORP
D13	1	D10	D <sup>10</sup>	G4	G <sup>3</sup>	N6	N <sup>3</sup>
D14	1	D9	D <sup>9</sup>	G2	G <sup>2</sup>	N8	N <sup>4</sup>
D12	1	D8	D <sup>8</sup>	G1	G <sup>1</sup>	N10	N <sup>5</sup>
C14	1	I	-	G0	G <sup>0</sup>	N12	N <sup>6</sup>
C13	1	NC	-	VCCO (Bank 1)	-	VCCO (Bank 1)	-
B14	-	TDO	-	TDO	-	TDO	-
A14	-	VCC	-	VCC	-	VCC	-
A13	-	GND	-	GND	-	GND	-
B13	1	NC	-	H14	H <sup>11</sup>	O12	O <sup>6</sup>
A12	1	I	-	H13	H <sup>10</sup>	O10	O <sup>5</sup>
C12	1	D7	D <sup>7</sup>	H12	H <sup>9</sup>	O8	O <sup>4</sup>
B12	1	D6	D <sup>6</sup>	H10	H <sup>8</sup>	O6	O <sup>3</sup>
A11	1	D5	D <sup>5</sup>	H9	H <sup>7</sup>	O4	O <sup>2</sup>
C11	1	D4	D <sup>4</sup>	H8	H <sup>6</sup>	O2	O <sup>1</sup>
B11	1	GND (Bank 1)	-	GND (Bank 1)	-	GND (Bank 1)	-
A10	1	VCCO (Bank 1)	-	VCCO (Bank 1)	-	VCCO (Bank 1)	-
B10	1	NC	-	H6	H <sup>5</sup>	P12	P <sup>6</sup>
C10	1	NC	-	H5	H <sup>4</sup>	P10	P <sup>5</sup>
B9	1	D3	D <sup>3</sup>	H4	H <sup>3</sup>	P8	P <sup>4</sup>
A9	1	D2	D <sup>2</sup>	H2	H <sup>2</sup>	P6	P <sup>3</sup>
C9	1	D1	D <sup>1</sup>	H1	H <sup>1</sup>	P4	P <sup>2</sup>
A8	1	D0/GOE1	D <sup>0</sup>	H0/GOE1	H <sup>0</sup>	P2/GOE1	P <sup>1</sup>
B8	1	CLK3/I	-	CLK3/I	-	CLK3/I	-
C8	0	CLK0/I	-	CLK0/I	-	CLK0/I	-
B7	-	VCC	-	VCC	-	VCC	-
A7	0	NC <sup>1</sup>	-	NC <sup>1</sup>	-	I <sup>1</sup>	-
C7	0	A0/GOE0	A <sup>0</sup>	A0/GOE0	A <sup>0</sup>	A2/GOE0	A <sup>1</sup>
A6	0	A1	A <sup>1</sup>	A1	A <sup>1</sup>	A4	A <sup>2</sup>
B6	0	A2	A <sup>2</sup>	A2	A <sup>2</sup>	A6	A <sup>3</sup>
C6	0	A3	A <sup>3</sup>	A4	A <sup>3</sup>	A8	A <sup>4</sup>
B5	0	NC	-	A5	A <sup>4</sup>	A10	A <sup>5</sup>
A5	0	NC	-	A6	A <sup>5</sup>	A12	A <sup>6</sup>
C5	0	VCCO (Bank 0)	-	VCCO (Bank 0)	-	VCCO (Bank 0)	-
B4	0	GND (Bank 0)	-	GND (Bank 0)	-	GND (Bank 0)	-
A4	0	NC	-	A8	A <sup>6</sup>	B2	B <sup>1</sup>
C4	0	A4	A <sup>4</sup>	A9	A <sup>7</sup>	B4	B <sup>2</sup>
A3	0	A5	A <sup>5</sup>	A10	A <sup>8</sup>	B6	B <sup>3</sup>
B3	0	A6	A <sup>6</sup>	A12	A <sup>9</sup>	B8	B <sup>4</sup>
A2	0	A7	A <sup>7</sup>	A13	A <sup>10</sup>	B10	B <sup>5</sup>
A1	0	NC	-	A14	A <sup>11</sup>	B12	B <sup>6</sup>

1. For device migration considerations, these NC pins are input signal pins in ispMACH 4256Z device.

**ispMACH 4128V and 4256V Logic Signal Connections: 144-Pin TQFP (Cont.)**

Pin Number	Bank Number	ispMACH 4128V		ispMACH 4256V	
		GLB/MC/Pad	ORP	GLB/MC/Pad	ORP
129	-	VCC	-	VCC	-
130	0	A0/GOE0	A^0	A2/GOE0	A^1
131	0	A1	A^1	A4	A^2
132	0	A2	A^2	A6	A^3
133	0	A4	A^3	A8	A^4
134	0	A5	A^4	A10	A^5
135	0	A6	A^5	A12	A^6
136	0	VCCO (Bank 0)	-	VCCO (Bank 0)	-
137	0	GND (Bank 0)	-	GND (Bank 0)	-
138	0	A8	A^6	B2	B^1
139	0	A9	A^7	B4	B^2
140	0	A10	A^8	B6	B^3
141	0	A12	A^9	B8	B^4
142	0	A13	A^10	B10	B^5
143	0	A14	A^11	B12	B^6
144	0	NC <sup>2</sup>	-	I <sup>2</sup>	-

1. For device migration considerations, these NC pins are GND pins for I/O banks in ispMACH 4128V devices.
2. For device migration considerations, these NC pins are input signal pins in ispMACH 4256V devices.

**ispMACH 4256V/B/C/Z, 4384V/B/C, 4512V/B/C, Logic Signal Connections: 176-Pin TQFP**

Pin Number	Bank Number	ispMACH 4256V/B/C/Z		ispMACH 4384V/B/C		ispMACH 4512V/B/C	
		GLB/MC/Pad	ORP	GLB/MC/Pad	ORP	GLB/MC/Pad	ORP
1	-	NC	-	NC	-	NC	-
2	-	GND	-	GND	-	GND	-
3	-	TDI	-	TDI	-	TDI	-
4	0	VCCO (Bank 0)	-	VCCO (Bank 0)	-	VCCO (Bank 0)	-
5	0	C14	C^7	C14	C^7	C14	C^7
6	0	C12	C^6	C12	C^6	C12	C^6
7	0	C10	C^5	C10	C^5	C10	C^5
8	0	C8	C^4	C8	C^4	C8	C^4
9	0	C6	C^3	C6	C^3	C6	C^3
10	0	C4	C^2	C4	C^2	C4	C^2
11	0	C2	C^1	C2	C^1	C2	C^1
12	0	C0	C^0	C0	C^0	C0	C^0
13	0	GND (Bank 0)	-	GND (Bank 0)	-	GND (Bank 0)	-
14	0	D14	D^7	E14	E^7	G14	G^7
15	0	D12	D^6	E12	E^6	G12	G^6
16	0	D10	D^5	E10	E^5	G10	G^5
17	0	D8	D^4	E8	E^4	G8	G^4
18	0	D6	D^3	E6	E^3	G6	G^3

**ispMACH 4256V/B/C, 4384V/B/C, 4512V/B/C Logic Signal Connections:  
256-Ball ftBGA/fpBGA**

Ball Number	I/O Bank	ispMACH 4256V/B/C 128-I/O		ispMACH 4256V/B/C 160-I/O		ispMACH 4384V/B/C		ispMACH 4512V/B/C	
		GLB/MC/Pad	ORP	GLB/MC/Pad	ORP	GLB/MC/Pad	ORP	GLB/MC/Pad	ORP
-	-	-	-	-	-	VCC	-	VCC	-
-	-	GND	-	GND	-	GND	-	GND	-
C3	-	TDI	-	TDI	-	TDI	-	TDI	-
-	0	VCCO (Bank 0)	-	VCCO (Bank 0)	-	VCCO (Bank 0)	-	VCCO (Bank 0)	-
B1	0	C14	C^7	C14	C^9	C14	C^7	C14	C^7
F5	0	C12	C^6	C12	C^8	C12	C^6	C12	C^6
D3	0	C10	C^5	C10	C^7	C10	C^5	C10	C^5
C1	0	C8	C^4	C9	C^6	C8	C^4	C8	C^4
C2	0	C6	C^3	C8	C^5	C6	C^3	C6	C^3
E3	0	C4	C^2	C6	C^4	C4	C^2	C4	C^2
D2	0	C2	C^1	C4	C^3	C2	C^1	C2	C^1
F6	0	C0	C^0	C2	C^2	C0	C^0	C0	C^0
D1	0	NC	-	C1	C^1	F6	F^3	H0	H^0
E2	0	NC	-	C0	C^0	F4	F^2	H4	H^1
E4	0	NC	-	NC	-	D6	D^3	F4	F^2
G5	0	NC	-	NC	-	D4	D^2	F6	F^3
E1	0	NC	-	NC	-	NC	-	F8	F^4
-	0	-	-	VCCO (Bank 0)	-	VCCO (Bank 0)	-	VCCO (Bank 0)	-
-	0	GND (Bank 0)	-	GND (Bank 0)	-	GND (Bank 0)	-	GND (Bank 0)	-
F2	0	NC	-	NC	-	NC	-	F10	F^5
F1	0	NC	-	NC	-	D2	D^1	F12	F^6
G1	0	NC	-	NC	-	D0	D^0	F14	F^7
G6	0	NC	-	D14	D^9	F2	F^1	H8	H^2
G4	0	NC	-	D12	D^8	F0	F^0	H12	H^3
H6	0	D14	D^7	D10	D^7	E14	E^7	G14	G^7
G3	0	D12	D^6	D9	D^6	E12	E^6	G12	G^6
H5	0	D10	D^5	D8	D^5	E10	E^5	G10	G^5
G2	0	D8	D^4	D6	D^4	E8	E^4	G8	G^4
H1	0	D6	D^3	D4	D^3	E6	E^3	G6	G^3
H2	0	D4	D^2	D2	D^2	E4	E^2	G4	G^2
H3	0	D2	D^1	D1	D^1	E2	E^1	G2	G^1
H4	0	D0	D^0	D0	D^0	E0	E^0	G0	G^0
-	0	VCCO (Bank 0)	-	VCCO (Bank 0)	-	VCCO (Bank 0)	-	VCCO (Bank 0)	-
-	0	-	-	GND (Bank 0)	-	GND (Bank 0)	-	GND (Bank 0)	-
J4	0	E0	E^0	E0	E^0	H0	H^0	J0	J^0
J3	0	E2	E^1	E1	E^1	H2	H^1	J2	J^1
J2	0	E4	E^2	E2	E^2	H4	H^2	J4	J^2
J1	0	E6	E^3	E4	E^3	H6	H^3	J6	J^3
K1	0	E8	E^4	E6	E^4	H8	H^4	J8	J^4
J5	0	E10	E^5	E8	E^5	H10	H^5	J10	J^5
K2	0	E12	E^6	E9	E^6	H12	H^6	J12	J^6

**ispMACH 4256V/B/C, 4384V/B/C, 4512V/B/C Logic Signal Connections:  
256-Ball ftBGA/fpBGA (Cont.)**

Ball Number	I/O Bank	ispMACH 4256V/B/C 128-I/O		ispMACH 4256V/B/C 160-I/O		ispMACH 4384V/B/C		ispMACH 4512V/B/C	
		GLB/MC/Pad	ORP	GLB/MC/Pad	ORP	GLB/MC/Pad	ORP	GLB/MC/Pad	ORP
H15	1	M2	M^1	M1	M^1	DX2	DX^1	JX2	JX^1
H14	1	M4	M^2	M2	M^2	DX4	DX^2	JX4	JX^2
H13	1	M6	M^3	M4	M^3	DX6	DX^3	JX6	JX^3
G16	1	M8	M^4	M6	M^4	DX8	DX^4	JX8	JX^4
H12	1	M10	M^5	M8	M^5	DX10	DX^5	JX10	JX^5
G15	1	M12	M^6	M9	M^6	DX12	DX^6	JX12	JX^6
H11	1	M14	M^7	M10	M^7	DX14	DX^7	JX14	JX^7
F16	1	NC	-	M12	M^8	CX0	CX^0	IX0	IX^0
G13	1	NC	-	M14	M^9	CX2	CX^1	IX4	IX^1
G14	1	NC	-	NC	-	EX14	EX^7	KX0	KX^0
F15	1	NC	-	NC	-	EX12	EX^6	KX2	KX^1
E16	1	NC	-	NC	-	NC	-	KX4	KX^2
-	1	GND (Bank 1)	-	GND (Bank 1)	-	GND (Bank 1)	-	GND (Bank 1)	-
-	1	-	-	VCCO (Bank 1)	-	VCCO (Bank 1)	-	VCCO (Bank 1)	-
E15	1	NC	-	NC	-	NC	-	KX6	KX^3
G12	1	NC	-	NC	-	EX10	EX^5	KX8	KX^4
E13	1	NC	-	NC	-	EX8	EX^4	KX10	KX^5
D16	1	NC	-	N0	N^0	CX4	CX^2	IX8	IX^2
E14	1	NC	-	N1	N^1	CX6	CX^3	IX12	IX^3
G11	1	N0	N^0	N2	N^2	FX0	FX^0	NX0	NX^0
D15	1	N2	N^1	N4	N^3	FX2	FX^1	NX2	NX^1
F11	1	N4	N^2	N6	N^4	FX4	FX^2	NX4	NX^2
C16	1	N6	N^3	N8	N^5	FX6	FX^3	NX6	NX^3
F12	1	N8	N^4	N9	N^6	FX8	FX^4	NX8	NX^4
D14	1	N10	N^5	N10	N^7	FX10	FX^5	NX10	NX^5
C15	1	N12	N^6	N12	N^8	FX12	FX^6	NX12	NX^6
B16	1	N14	N^7	N14	N^9	FX14	FX^7	NX14	NX^7
-	1	VCCO (Bank 1)	-	VCCO (Bank 1)	-	VCCO (Bank 1)	-	VCCO (Bank 1)	-
C14	-	TDO	-	TDO	-	TDO	-	TDO	-
-	-	VCC	-	VCC	-	VCC	-	VCC	-
-	-	GND	-	GND	-	GND	-	GND	-
-	1	-	-	GND (Bank 1)	-	GND (Bank 1)	-	GND (Bank 1)	-
A15	1	NC	-	NC	-	EX6	EX^3	KX12	KX^6
B14	1	NC	-	NC	-	EX4	EX^2	KX14	KX^7
E12	1	O14	O^7	O14	O^9	GX14	GX^7	OX14	OX^7
A14	1	O12	O^6	O12	O^8	GX12	GX^6	OX12	OX^6
C13	1	O10	O^5	O10	O^7	GX10	GX^5	OX10	OX^5
D13	1	O8	O^4	O9	O^6	GX8	GX^4	OX8	OX^4
E11	1	O6	O^3	O8	O^5	GX6	GX^3	OX6	OX^3
B13	1	O4	O^2	O6	O^4	GX4	GX^2	OX4	OX^2
F10	1	O2	O^1	O4	O^3	GX2	GX^1	OX2	OX^1



**ispMACH 4256V/B/C, 4384V/B/C, 4512V/B/C Logic Signal Connections:  
256-Ball ftBGA/fpBGA (Cont.)**

Ball Number	I/O Bank	ispMACH 4256V/B/C 128-I/O		ispMACH 4256V/B/C 160-I/O		ispMACH 4384V/B/C		ispMACH 4512V/B/C	
		GLB/MC/Pad	ORP	GLB/MC/Pad	ORP	GLB/MC/Pad	ORP	GLB/MC/Pad	ORP
E7	0	NC	-	B1	B^1	F8	F^4	D12	D^3
A3	0	B0	B^0	B2	B^2	B0	B^0	B0	B^0
F7	0	B2	B^1	B4	B^3	B2	B^1	B2	B^1
B4	0	B4	B^2	B6	B^4	B4	B^2	B4	B^2
C5	0	B6	B^3	B8	B^5	B6	B^3	B6	B^3
A2	0	B8	B^4	B9	B^6	B8	B^4	B8	B^4
E6	0	B10	B^5	B10	B^7	B10	B^5	B10	B^5
B3	0	B12	B^6	B12	B^8	B12	B^6	B12	B^6
C4	0	B14	B^7	B14	B^9	B14	B^7	B14	B^7
D4	0	NC	-	NC	-	D10	D^5	F0	F^0
E5	0	NC	-	NC	-	D8	D^4	F2	F^1
-	-	VCC	-	VCC	-	VCC	-	VCC	-
-	-	-	-	-	-	GND	-	GND	-
-	0	-	-	-	-	GND (Bank 0)	-	GND (Bank 0)	-

Note: VCC, VCCO and GND are tied together to their respective common signal on the package substrate. See Power Supply and NC Connections table for VCC/ VCCO/GND pin definitions.

## ispMACH 4000C (1.8V) Commercial Devices (Cont.)

Device	Part Number	Macrocells	Voltage	t <sub>PD</sub>	Package	Pin/Ball Count	I/O	Grade
LC4128C	LC4128C-27T128C	128	1.8	2.7	TQFP	128	92	C
	LC4128C-5T128C	128	1.8	5	TQFP	128	92	C
	LC4128C-75T128C	128	1.8	7.5	TQFP	128	92	C
	LC4128C-27T100C	128	1.8	2.7	TQFP	100	64	C
	LC4128C-5T100C	128	1.8	5	TQFP	100	64	C
	LC4128C-75T100C	128	1.8	7.5	TQFP	100	64	C
LC4256C	LC4256C-3FT256AC	256	1.8	3	ftBGA	256	128	C
	LC4256C-5FT256AC	256	1.8	5	ftBGA	256	128	C
	LC4256C-75FT256AC	256	1.8	7.5	ftBGA	256	128	C
	LC4256C-3FT256BC	256	1.8	3	ftBGA	256	160	C
	LC4256C-5FT256BC	256	1.8	5	ftBGA	256	160	C
	LC4256C-75FT256BC	256	1.8	7.5	ftBGA	256	160	C
	LC4256C-3F256AC <sup>1</sup>	256	1.8	3	fpBGA	256	128	C
	LC4256C-5F256AC <sup>1</sup>	256	1.8	5	fpBGA	256	128	C
	LC4256C-75F256AC <sup>1</sup>	256	1.8	7.5	fpBGA	256	128	C
	LC4256C-3F256BC <sup>1</sup>	256	1.8	3	fpBGA	256	160	C
	LC4256C-5F256BC <sup>1</sup>	256	1.8	5	fpBGA	256	160	C
	LC4256C-75F256BC <sup>1</sup>	256	1.8	7.5	fpBGA	256	160	C
	LC4256C-3T176C	256	1.8	3	TQFP	176	128	C
	LC4256C-5T176C	256	1.8	5	TQFP	176	128	C
	LC4256C-75T176C	256	1.8	7.5	TQFP	176	128	C
	LC4256C-3T100C	256	1.8	3	TQFP	100	64	C
LC4256C-5T100C	256	1.8	5	TQFP	100	64	C	
LC4256C-75T100C	256	1.8	7.5	TQFP	100	64	C	
LC4384C	LC4384C-35FT256C	384	1.8	3.5	ftBGA	256	192	C
	LC4384C-5FT256C	384	1.8	5	ftBGA	256	192	C
	LC4384C-75FT256C	384	1.8	7.5	ftBGA	256	192	C
	LC4384C-35F256C <sup>1</sup>	384	1.8	3.5	fpBGA	256	192	C
	LC4384C-5F256C <sup>1</sup>	384	1.8	5	fpBGA	256	192	C
	LC4384C-75F256C <sup>1</sup>	384	1.8	7.5	fpBGA	256	192	C
	LC4384C-35T176C	384	1.8	3.5	TQFP	176	128	C
	LC4384C-5T176C	384	1.8	5	TQFP	176	128	C
	LC4384C-75T176C	384	1.8	7.5	TQFP	176	128	C
LC4512C	LC4512C-35FT256C	512	1.8	3.5	ftBGA	256	208	C
	LC4512C-5FT256C	512	1.8	5	ftBGA	256	208	C
	LC4512C-75FT256C	512	1.8	7.5	ftBGA	256	208	C
	LC4512C-35F256C <sup>1</sup>	512	1.8	3.5	fpBGA	256	208	C
	LC4512C-5F256C <sup>1</sup>	512	1.8	5	fpBGA	256	208	C
	LC4512C-75F256C <sup>1</sup>	512	1.8	7.5	fpBGA	256	208	C
	LC4512C-35T176C	512	1.8	3.5	TQFP	176	128	C
	LC4512C-5T176C	512	1.8	5	TQFP	176	128	C
	LC4512C-75T176C	512	1.8	7.5	TQFP	176	128	C

1. Use ftBGA package. fpBGA package devices have been discontinued via PCN#14A-07.

## ispMACH 4000C (1.8V) Industrial Devices

Family	Part Number	Macrocells	Voltage	t <sub>PD</sub>	Package	Pin/Ball Count	I/O	Grade
LC4032C	LC4032C-5T48I	32	1.8	5	TQFP	48	32	I
	LC4032C-75T48I	32	1.8	7.5	TQFP	48	32	I
	LC4032C-10T48I	32	1.8	10	TQFP	48	32	I
	LC4032C-5T44I	32	1.8	5	TQFP	44	30	I
	LC4032C-75T44I	32	1.8	7.5	TQFP	44	30	I
	LC4032C-10T44I	32	1.8	10	TQFP	44	30	I
LC4064C	LC4064C-5T100I	64	1.8	5	TQFP	100	64	I
	LC4064C-75T100I	64	1.8	7.5	TQFP	100	64	I
	LC4064C-10T100I	64	1.8	10	TQFP	100	64	I
	LC4064C-5T48I	64	1.8	5	TQFP	48	32	I
	LC4064C-75T48I	64	1.8	7.5	TQFP	48	32	I
	LC4064C-10T48I	64	1.8	10	TQFP	48	32	I
	LC4064C-5T44I	64	1.8	5	TQFP	44	30	I
	LC4064C-75T44I	64	1.8	7.5	TQFP	44	30	I
LC4128C	LC4128C-5T128I	128	1.8	5	TQFP	128	92	I
	LC4128C-75T128I	128	1.8	7.5	TQFP	128	92	I
	LC4128C-10T128I	128	1.8	10	TQFP	128	92	I
	LC4128C-5T100I	128	1.8	5	TQFP	100	64	I
	LC4128C-75T100I	128	1.8	7.5	TQFP	100	64	I
	LC4128C-10T100I	128	1.8	10	TQFP	100	64	I
LC4256C	LC4256C-5FT256AI	256	1.8	5	ftBGA	256	128	I
	LC4256C-75FT256AI	256	1.8	7.5	ftBGA	256	128	I
	LC4256C-10FT256AI	256	1.8	10	ftBGA	256	128	I
	LC4256C-5FT256BI	256	1.8	5	ftBGA	256	160	I
	LC4256C-75FT256BI	256	1.8	7.5	ftBGA	256	160	I
	LC4256C-10FT256BI	256	1.8	10	ftBGA	256	160	I
	LC4256C-5F256AI <sup>1</sup>	256	1.8	5	fpBGA	256	128	I
	LC4256C-75F256AI <sup>1</sup>	256	1.8	7.5	fpBGA	256	128	I
	LC4256C-10F256AI <sup>1</sup>	256	1.8	10	fpBGA	256	128	I
	LC4256C-5F256BI <sup>1</sup>	256	1.8	5	fpBGA	256	160	I
	LC4256C-75F256BI <sup>1</sup>	256	1.8	7.5	fpBGA	256	160	I
	LC4256C-10F256BI <sup>1</sup>	256	1.8	10	fpBGA	256	160	I
	LC4256C-5T176I	256	1.8	5	TQFP	176	128	I
	LC4256C-75T176I	256	1.8	7.5	TQFP	176	128	I
	LC4256C-10T176I	256	1.8	10	TQFP	176	128	I
	LC4256C-5T100I	256	1.8	5	TQFP	100	64	I
	LC4256C-75T100I	256	1.8	7.5	TQFP	100	64	I
	LC4256C-10T100I	256	1.8	10	TQFP	100	64	I

## ispMACH 4000V (3.3V) Lead-Free Commercial Devices (Cont.)

Device	Part Number	Macrocells	Voltage	t <sub>PD</sub>	Package	Pin/Ball Count	I/O	Grade
LC4256V	LC4256V-3FTN256AC	256	3.3	3	Lead-free ftBGA	256	128	C
	LC4256V-5FTN256AC	256	3.3	5	Lead-free ftBGA	256	128	C
	LC4256V-75FTN256AC	256	3.3	7.5	Lead-free ftBGA	256	128	C
	LC4256V-3FTN256BC	256	3.3	3	Lead-free ftBGA	256	160	C
	LC4256V-5FTN256BC	256	3.3	5	Lead-free ftBGA	256	160	C
	LC4256V-75FTN256BC	256	3.3	7.5	Lead-free ftBGA	256	160	C
	LC4256V-3FN256AC <sup>1</sup>	256	3.3	3	Lead-free fpBGA	256	128	C
	LC4256V-5FN256AC <sup>1</sup>	256	3.3	5	Lead-free fpBGA	256	128	C
	LC4256V-75FN256AC <sup>1</sup>	256	3.3	7.5	Lead-free fpBGA	256	128	C
	LC4256V-3FN256BC <sup>1</sup>	256	3.3	3	Lead-free fpBGA	256	160	C
	LC4256V-5FN256BC <sup>1</sup>	256	3.3	5	Lead-free fpBGA	256	160	C
	LC4256V-75FN256BC <sup>1</sup>	256	3.3	7.5	Lead-free fpBGA	256	160	C
	LC4256V-3TN176C	256	3.3	3	Lead-free TQFP	176	128	C
	LC4256V-5TN176C	256	3.3	5	Lead-free TQFP	176	128	C
	LC4256V-75TN176C	256	3.3	7.5	Lead-free TQFP	176	128	C
	LC4256V-3TN144C	256	3.3	3	Lead-free TQFP	144	96	C
	LC4256V-5TN144C	256	3.3	5	Lead-free TQFP	144	96	C
	LC4256V-75TN144C	256	3.3	7.5	Lead-free TQFP	144	96	C
	LC4256V-3TN100C	256	3.3	3	Lead-free TQFP	100	64	C
	LC4256V-5TN100C	256	3.3	5	Lead-free TQFP	100	64	C
LC4256V-75TN100C	256	3.3	7.5	Lead-free TQFP	100	64	C	
LC4384V	LC4384V-35FTN256C	384	3.3	3.5	Lead-free ftBGA	256	192	C
	LC4384V-5FTN256C	384	3.3	5	Lead-free ftBGA	256	192	C
	LC4384V-75FTN256C	384	3.3	7.5	Lead-free ftBGA	256	192	C
	LC4384V-35FN256C <sup>1</sup>	384	3.3	3.5	Lead-free fpBGA	256	192	C
	LC4384V-5FN256C <sup>1</sup>	384	3.3	5	Lead-free fpBGA	256	192	C
	LC4384V-75FN256C <sup>1</sup>	384	3.3	7.5	Lead-free fpBGA	256	192	C
	LC4384V-35TN176C	384	3.3	3.5	Lead-free TQFP	176	128	C
	LC4384V-5TN176C	384	3.3	5	Lead-free TQFP	176	128	C
LC4384V-75TN176C	384	3.3	7.5	Lead-free TQFP	176	128	C	
LC4512V	LC4512V-35FTN256C	512	3.3	3.5	Lead-free ftBGA	256	208	C
	LC4512V-5FTN256C	512	3.3	5	Lead-free ftBGA	256	208	C
	LC4512V-75FTN256C	512	3.3	7.5	Lead-free ftBGA	256	208	C
	LC4512V-35FN256C <sup>1</sup>	512	3.3	3.5	Lead-free fpBGA	256	208	C
	LC4512V-5FN256C <sup>1</sup>	512	3.3	5	Lead-free fpBGA	256	208	C
	LC4512V-75FN256C <sup>1</sup>	512	3.3	7.5	Lead-free fpBGA	256	208	C
	LC4512V-35TN176C	512	3.3	3.5	Lead-free TQFP	176	128	C
	LC4512V-5TN176C	512	3.3	5	Lead-free TQFP	176	128	C
	LC4512V-75TN176C	512	3.3	7.5	Lead-free TQFP	176	128	C

1. Use ftBGA package. fpBGA package devices have been discontinued via PCN#14A-07.

## ispMACH 4000V (3.3V) Lead-Free Industrial Devices (Cont.)

Device	Part Number	Macrocells	Voltage	t <sub>PD</sub>	Package	Pin/Ball Count	I/O	Grade
LC4256V	LC4256V-5FTN256AI	256	3.3	5	Lead-free ftBGA	256	128	I
	LC4256V-75FTN256AI	256	3.3	7.5	Lead-free ftBGA	256	128	I
	LC4256V-10FTN256AI	256	3.3	10	Lead-free ftBGA	256	128	I
	LC4256V-5FTN256BI	256	3.3	5	Lead-free ftBGA	256	160	I
	LC4256V-75FTN256BI	256	3.3	7.5	Lead-free ftBGA	256	160	I
	LC4256V-10FTN256BI	256	3.3	10	Lead-free ftBGA	256	160	I
	LC4256V-5FN256AI <sup>1</sup>	256	3.3	5	Lead-free fpBGA	256	128	I
	LC4256V-75FN256AI <sup>1</sup>	256	3.3	7.5	Lead-free fpBGA	256	128	I
	LC4256V-10FN256AI <sup>1</sup>	256	3.3	10	Lead-free fpBGA	256	128	I
	LC4256V-5FN256BI <sup>1</sup>	256	3.3	5	Lead-free fpBGA	256	160	I
	LC4256V-75FN256BI <sup>1</sup>	256	3.3	7.5	Lead-free fpBGA	256	160	I
	LC4256V-10FN256BI <sup>1</sup>	256	3.3	10	Lead-free fpBGA	256	160	I
	LC4256V-5TN176I	256	3.3	5	Lead-free TQFP	176	128	I
	LC4256V-75TN176I	256	3.3	7.5	Lead-free TQFP	176	128	I
	LC4256V-10TN176I	256	3.3	10	Lead-free TQFP	176	128	I
	LC4256V-5TN144I	256	3.3	5	Lead-free TQFP	144	96	I
	LC4256V-75TN144I	256	3.3	7.5	Lead-free TQFP	144	96	I
	LC4256V-10TN144I	256	3.3	10	Lead-free TQFP	144	96	I
	LC4256V-5TN100I	256	3.3	5	Lead-free TQFP	100	64	I
	LC4256V-75TN100I	256	3.3	7.5	Lead-free TQFP	100	64	I
LC4256V-10TN100I	256	3.3	10	Lead-free TQFP	100	64	I	
LC4384V	LC4384V-5FTN256I	384	3.3	5	Lead-free ftBGA	256	192	I
	LC4384V-75FTN256I	384	3.3	7.5	Lead-free ftBGA	256	192	I
	LC4384V-10FTN256I	384	3.3	10	Lead-free ftBGA	256	192	I
	LC4384V-5FN256I <sup>1</sup>	384	3.3	5	Lead-free fpBGA	256	192	I
	LC4384V-75FN256I <sup>1</sup>	384	3.3	7.5	Lead-free fpBGA	256	192	I
	LC4384V-10FN256I <sup>1</sup>	384	3.3	10	Lead-free fpBGA	256	192	I
	LC4384V-5TN176I	384	3.3	5	Lead-free TQFP	176	128	I
	LC4384V-75TN176I	384	3.3	7.5	Lead-free TQFP	176	128	I
LC4384V-10TN176I	384	3.3	10	Lead-free TQFP	176	128	I	
LC4512V	LC4512V-5FTN256I	512	3.3	5	Lead-free ftBGA	256	208	I
	LC4512V-75FTN256I	512	3.3	7.5	Lead-free ftBGA	256	208	I
	LC4512V-10FTN256I	512	3.3	10	Lead-free ftBGA	256	208	I
	LC4512V-5FN256I <sup>1</sup>	512	3.3	5	Lead-free fpBGA	256	208	I
	LC4512V-75FN256I <sup>1</sup>	512	3.3	7.5	Lead-free fpBGA	256	208	I
	LC4512V-10FN256I <sup>1</sup>	512	3.3	10	Lead-free fpBGA	256	208	I
	LC4512V-5TN176I	512	3.3	5	Lead-free TQFP	176	128	I
	LC4512V-75TN176I	512	3.3	7.5	Lead-free TQFP	176	128	I
	LC4512V-10TN176I	512	3.3	10	Lead-free TQFP	176	128	I

1. Use ftBGA package. fpBGA package devices have been discontinued via PCN#14A-07.