

Welcome to [E-XFL.COM](https://www.e-xfl.com)

Understanding [Embedded - CPLDs \(Complex Programmable Logic Devices\)](#)

Embedded - CPLDs, or Complex Programmable Logic Devices, are highly versatile digital logic devices used in electronic systems. These programmable components are designed to perform complex logical operations and can be customized for specific applications. Unlike fixed-function ICs, CPLDs offer the flexibility to reprogram their configuration, making them an ideal choice for various embedded systems. They consist of a set of logic gates and programmable interconnects, allowing designers to implement complex logic circuits without needing custom hardware.

Applications of Embedded - CPLDs

Details

Product Status	Active
Programmable Type	In System Programmable
Delay Time tpd(1) Max	7.5 ns
Voltage Supply - Internal	1.7V ~ 1.9V
Number of Logic Elements/Blocks	8
Number of Macrocells	128
Number of Gates	-
Number of I/O	96
Operating Temperature	0°C ~ 90°C (TJ)
Mounting Type	Surface Mount
Package / Case	132-LFBGA, CSPBGA
Supplier Device Package	132-CSBGA (8x8)
Purchase URL	https://www.e-xfl.com/product-detail/lattice-semiconductor/lc4128zc-75mn132c

Figure 3. AND Array

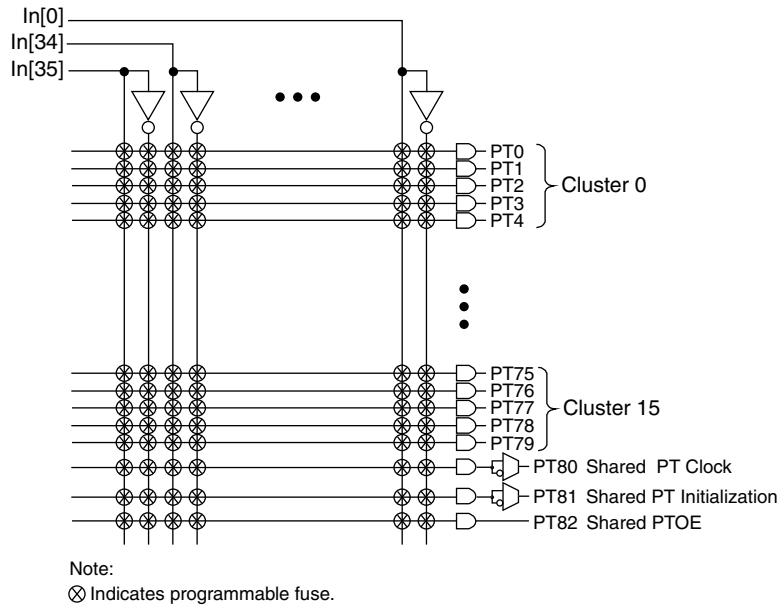

Enhanced Logic Allocator

Within the logic allocator, product terms are allocated to macrocells in product term clusters. Each product term cluster is associated with a macrocell. The cluster size for the ispMACH 4000 family is 4+1 (total 5) product terms. The software automatically considers the availability and distribution of product term clusters as it fits the functions within a GLB. The logic allocator is designed to provide three speed paths: 5-PT fast bypass path, 20-PT Speed Locking path and an up to 80-PT path. The availability of these three paths lets designers trade timing variability for increased performance.

The enhanced Logic Allocator of the ispMACH 4000 family consists of the following blocks:

- Product Term Allocator
- Cluster Allocator
- Wide Steering Logic

Figure 4 shows a macrocell slice of the Logic Allocator. There are 16 such slices in the GLB.

Figure 4. Macrocell Slice

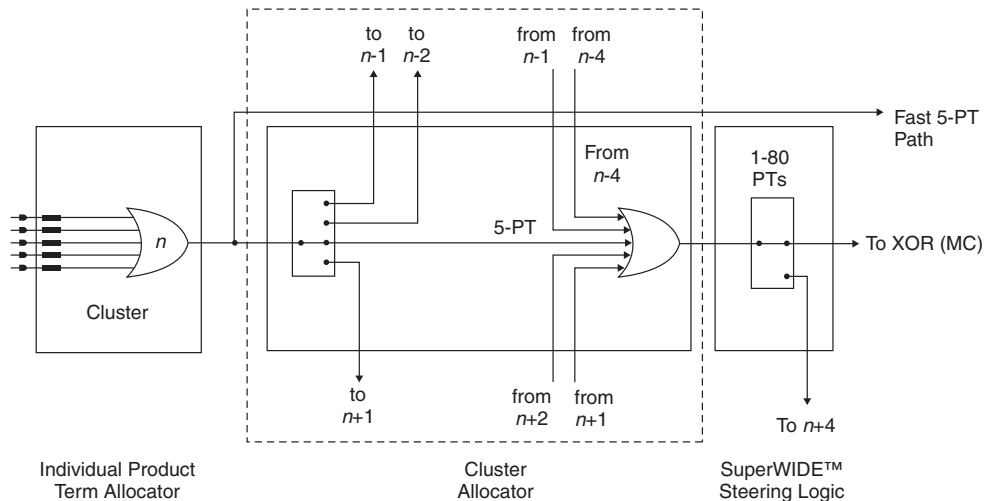

Product Term Allocator

The product term allocator assigns product terms from a cluster to either logic or control applications as required by the design being implemented. Product terms that are used as logic are steered into a 5-input OR gate associated with the cluster. Product terms that used for control are steered either to the macrocell or I/O cell associated with the cluster. Table 3 shows the available functions for each of the five product terms in the cluster. The OR gate output connects to the associated I/O cell, providing a fast path for narrow combinatorial functions, and to the logic allocator.

Table 3. Individual PT Steering

Product Term	Logic	Control
PT n	Logic PT	Single PT for XOR/OR
PT $n+1$	Logic PT	Individual Clock (PT Clock)
PT $n+2$	Logic PT	Individual Initialization or Individual Clock Enable (PT Initialization/CE)
PT $n+3$	Logic PT	Individual Initialization (PT Initialization)
PT $n+4$	Logic PT	Individual OE (PTOE)

Cluster Allocator

The cluster allocator allows clusters to be steered to neighboring macrocells, thus allowing the creation of functions with more product terms. Table 4 shows which clusters can be steered to which macrocells. Used in this manner, the cluster allocator can be used to form functions of up to 20 product terms. Additionally, the cluster allocator accepts inputs from the wide steering logic. Using these inputs, functions up to 80 product terms can be created.

Table 4. Available Clusters for Each Macrocell

Macrocell	Available Clusters			
M0	—	C0	C1	C2
M1	C0	C1	C2	C3
M2	C1	C2	C3	C4
M3	C2	C3	C4	C5
M4	C3	C4	C5	C6
M5	C4	C5	C6	C7
M6	C5	C6	C7	C8
M7	C6	C7	C8	C9
M8	C7	C8	C9	C10
M9	C8	C9	C10	C11
M10	C9	C10	C11	C12
M11	C10	C11	C12	C13
M12	C11	C12	C13	C14
M13	C12	C13	C14	C15
M14	C13	C14	C15	—
M15	C14	C15	—	—

Wide Steering Logic

The wide steering logic allows the output of the cluster allocator n to be connected to the input of the cluster allocator $n+4$. Thus, cluster chains can be formed with up to 80 product terms, supporting wide product term functions and allowing performance to be increased through a single GLB implementation. Table 5 shows the product term chains.

Table 7. ORP Combinations for I/O Blocks with 16 I/Os

I/O Cell	Available Macrocells
I/O 0	M0, M1, M2, M3, M4, M5, M6, M7
I/O 1	M1, M2, M3, M4, M5, M6, M7, M8
I/O 2	M2, M3, M4, M5, M6, M7, M8, M9
I/O 3	M3, M4, M5, M6, M7, M8, M9, M10
I/O 4	M4, M5, M6, M7, M8, M9, M10, M11
I/O 5	M5, M6, M7, M8, M9, M10, M11, M12
I/O 6	M6, M7, M8, M9, M10, M11, M12, M13
I/O 7	M7, M8, M9, M10, M11, M12, M13, M14
I/O 8	M8, M9, M10, M11, M12, M13, M14, M15
I/O 9	M9, M10, M11, M12, M13, M14, M15, M0
I/O 10	M10, M11, M12, M13, M14, M15, M0, M1
I/O 11	M11, M12, M13, M14, M15, M0, M1, M2
I/O 12	M12, M13, M14, M15, M0, M1, M2, M3
I/O 13	M13, M14, M15, M0, M1, M2, M3, M4
I/O 14	M14, M15, M0, M1, M2, M3, M4, M5
I/O 15	M15, M0, M1, M2, M3, M4, M5, M6

Table 8. ORP Combinations for I/O Blocks with 4 I/Os

I/O Cell	Available Macrocells
I/O 0	M0, M1, M2, M3, M4, M5, M6, M7
I/O 1	M4, M5, M6, M7, M8, M9, M10, M11
I/O 2	M8, M9, M10, M11, M12, M13, M14, M15
I/O 3	M12, M13, M14, M15, M0, M1, M2, M3

Table 9. ORP Combinations for I/O Blocks with 10 I/Os

I/O Cell	Available Macrocells
I/O 0	M0, M1, M2, M3, M4, M5, M6, M7
I/O 1	M2, M3, M4, M5, M6, M7, M8, M9
I/O 2	M4, M5, M6, M7, M8, M9, M10, M11
I/O 3	M6, M7, M8, M9, M10, M11, M12, M13
I/O 4	M8, M9, M10, M11, M12, M13, M14, M15
I/O 5	M10, M11, M12, M13, M14, M15, M0, M1
I/O 6	M12, M13, M14, M15, M0, M1, M2, M3
I/O 7	M14, M15, M0, M1, M2, M3, M4, M5
I/O 8	M2, M3, M4, M5, M6, M7, M8, M9
I/O 9	M10, M11, M12, M13, M14, M15, M0, M1

Figure 10. Global OE Generation for ispMACH 4032



Zero Power/Low Power and Power Management

The ispMACH 4000 family is designed with high speed low power design techniques to offer both high speed and low power. With an advanced E^2 low power cell and non sense-amplifier design approach (full CMOS logic approach), the ispMACH 4000 family offers SuperFAST pin-to-pin speeds, while simultaneously delivering low standby power without needing any “turbo bits” or other power management schemes associated with a traditional sense-amplifier approach.

The zero power ispMACH 4000Z is based on the 1.8V ispMACH 4000C family. With innovative circuit design changes, the ispMACH 4000Z family is able to achieve the industry’s “lowest static power”.

IEEE 1149.1-Compliant Boundary Scan Testability

All ispMACH 4000 devices have boundary scan cells and are compliant to the IEEE 1149.1 standard. This allows functional testing of the circuit board on which the device is mounted through a serial scan path that can access all critical logic nodes. Internal registers are linked internally, allowing test data to be shifted in and loaded directly onto test nodes, or test node data to be captured and shifted out for verification. In addition, these devices can be linked into a board-level serial scan path for more board-level testing. The test access port operates with an LVCMOS interface that corresponds to the power supply voltage.

I/O Quick Configuration

To facilitate the most efficient board test, the physical nature of the I/O cells must be set before running any continuity tests. As these tests are fast, by nature, the overhead and time that is required for configuration of the I/Os’ physical nature should be minimal so that board test time is minimized. The ispMACH 4000 family of devices allows this by offering the user the ability to quickly configure the physical nature of the I/O cells. This quick configuration takes milliseconds to complete, whereas it takes seconds for the entire device to be programmed. Lattice’s ispVM[®] System programming software can either perform the quick configuration through the PC parallel port, or can generate the ATE or test vectors necessary for a third-party test system.

Supply Current, ispMACH 4000V/B/C

Over Recommended Operating Conditions

Symbol	Parameter	Condition	Min.	Typ.	Max.	Units
ispMACH 4032V/B/C						
ICC ^{1,2,3}	Operating Power Supply Current	V _{CC} = 3.3V	—	11.8	—	mA
		V _{CC} = 2.5V	—	11.8	—	mA
		V _{CC} = 1.8V	—	1.8	—	mA
ICC ⁴	Standby Power Supply Current	V _{CC} = 3.3V	—	11.3	—	mA
		V _{CC} = 2.5V	—	11.3	—	mA
		V _{CC} = 1.8V	—	1.3	—	mA
ispMACH 4064V/B/C						
ICC ^{1,2,3}	Operating Power Supply Current	V _{CC} = 3.3V	—	12	—	mA
		V _{CC} = 2.5V	—	12	—	mA
		V _{CC} = 1.8V	—	2	—	mA
ICC ⁵	Standby Power Supply Current	V _{CC} = 3.3V	—	11.5	—	mA
		V _{CC} = 2.5V	—	11.5	—	mA
		V _{CC} = 1.8V	—	1.5	—	mA
ispMACH 4128V/B/C						
ICC ^{1,2,3}	Operating Power Supply Current	V _{CC} = 3.3V	—	12	—	mA
		V _{CC} = 2.5V	—	12	—	mA
		V _{CC} = 1.8V	—	2	—	mA
ICC ⁴	Standby Power Supply Current	V _{CC} = 3.3V	—	11.5	—	mA
		V _{CC} = 2.5V	—	11.5	—	mA
		V _{CC} = 1.8V	—	1.5	—	mA
ispMACH 4256V/B/C						
I _{CC} ^{1,2,3}	Operating Power Supply Current	V _{CC} = 3.3V	—	12.5	—	mA
		V _{CC} = 2.5V	—	12.5	—	mA
		V _{CC} = 1.8V	—	2.5	—	mA
I _{CC} ⁴	Standby Power Supply Current	V _{CC} = 3.3V	—	12	—	mA
		V _{CC} = 2.5V	—	12	—	mA
		V _{CC} = 1.8V	—	2	—	mA
ispMACH 4384V/B/C						
I _{CC} ^{1,2,3}	Operating Power Supply Current	V _{CC} = 3.3V	—	13.5	—	mA
		V _{CC} = 2.5V	—	13.5	—	mA
		V _{CC} = 1.8V	—	3.5	—	mA
I _{CC} ⁴	Standby Power Supply Current	V _{CC} = 3.3V	—	12.5	—	mA
		V _{CC} = 2.5V	—	12.5	—	mA
		V _{CC} = 1.8V	—	2.5	—	mA
ispMACH 4512V/B/C						
I _{CC} ^{1,2,3}	Operating Power Supply Current	V _{CC} = 3.3V	—	14	—	mA
		V _{CC} = 2.5V	—	14	—	mA
		V _{CC} = 1.8V	—	4	—	mA

ispMACH 4000V/B/C External Switching Characteristics

Over Recommended Operating Conditions

Parameter	Description ^{1, 2, 3}	-25		-27		-3		-35		Units
		Min.	Max.	Min.	Max.	Min.	Max.	Min.	Max.	
t _{PD}	5-PT bypass combinatorial propagation delay	—	2.5	—	2.7	—	3.0	—	3.5	ns
t _{PD_MC}	20-PT combinatorial propagation delay through macrocell	—	3.2	—	3.5	—	3.8	—	4.2	ns
t _S	GLB register setup time before clock	1.8	—	1.8	—	2.0	—	2.0	—	ns
t _{ST}	GLB register setup time before clock with T-type register	2.0	—	2.0	—	2.2	—	2.2	—	ns
t _{SIR}	GLB register setup time before clock, input register path	0.7	—	1.0	—	1.0	—	1.0	—	ns
t _{SIRZ}	GLB register setup time before clock with zero hold	1.7	—	2.0	—	2.0	—	2.0	—	ns
t _H	GLB register hold time after clock	0.0	—	0.0	—	0.0	—	0.0	—	ns
t _{HT}	GLB register hold time after clock with T-type register	0.0	—	0.0	—	0.0	—	0.0	—	ns
t _{HIR}	GLB register hold time after clock, input register path	0.9	—	1.0	—	1.0	—	1.0	—	ns
t _{HIRZ}	GLB register hold time after clock, input register path with zero hold	0.0	—	0.0	—	0.0	—	0.0	—	ns
t _{CO}	GLB register clock-to-output delay	—	2.2	—	2.7	—	2.7	—	2.7	ns
t _R	External reset pin to output delay	—	3.5	—	4.0	—	4.4	—	4.5	ns
t _{RW}	External reset pulse duration	1.5	—	1.5	—	1.5	—	1.5	-	ns
t _{P_{TOE/DIS}}	Input to output local product term output enable/disable	—	4.0	—	4.5	—	5.0	—	5.5	ns
t _{G_{P_{TOE/DIS}}}	Input to output global product term output enable/disable	—	5.0	—	6.5	—	8.0	—	8.0	ns
t _{G_{OE/DIS}}	Global OE input to output enable/disable	—	3.0	—	3.5	—	4.0	—	4.5	ns
t _{CW}	Global clock width, high or low	1.1	—	1.3	—	1.3	—	1.3	—	ns
t _{GW}	Global gate width low (for low transparent) or high (for high transparent)	1.1	—	1.3	—	1.3	—	1.3	—	ns
t _{WIR}	Input register clock width, high or low	1.1	—	1.3	—	1.3	—	1.3	—	ns
f _{MAX} ⁴	Clock frequency with internal feedback	—	400	—	333	—	322	—	322	MHz
f _{MAX} (Ext.)	Clock frequency with external feedback, [1/ (t _S + t _{CO})]	—	250	—	222	—	212	—	212	MHz

1. Timing numbers are based on default LVCMOS 1.8 I/O buffers. Use timing adjusters provided to calculate other standards.

Timing v.3.2

2. Measured using standard switching circuit, assuming GRP loading of 1 and 1 output switching.

3. Pulse widths and clock widths less than minimum will cause unknown behavior.

4. Standard 16-bit counter using GRP feedback.

ispMACH 4000Z External Switching Characteristics (Cont.)

Over Recommended Operating Conditions

Parameter	Description ^{1, 2, 3}	-45		-5		-75		Units
		Min.	Max.	Min.	Max.	Min.	Max.	
t _{PD}	5-PT bypass combinatorial propagation delay	—	4.5	—	5.0	—	7.5	ns
t _{PD_MC}	20-PT combinatorial propagation delay through macrocell	—	5.8	—	6.0	—	8.0	ns
t _S	GLB register setup time before clock	2.9	—	3.0	—	4.5	—	ns
t _{ST}	GLB register setup time before clock with T-type register	3.1	—	3.2	—	4.7	—	ns
t _{SIR}	GLB register setup time before clock, input register path	1.3	—	1.3	—	1.4	—	ns
t _{SIRZ}	GLB register setup time before clock with zero hold	2.6	—	2.6	—	2.7	—	ns
t _H	GLB register hold time after clock	0.0	—	0.0	—	0.0	—	ns
t _{HT}	GLB register hold time after clock with T-type register	0.0	—	0.0	—	0.0	—	ns
t _{HIR}	GLB register hold time after clock, input register path	1.3	—	1.3	—	1.3	—	ns
t _{HIRZ}	GLB register hold time after clock, input register path with zero hold	0.0	—	0.0	—	0.0	—	ns
t _{CO}	GLB register clock-to-output delay	—	3.8	—	4.2	—	4.5	ns
t _R	External reset pin to output delay	—	7.5	—	7.5	—	9.0	ns
t _{RW}	External reset pulse duration	2.0	—	2.0	—	4.0	—	ns
t _{P_{TOE/DIS}}	Input to output local product term output enable/disable	—	8.2	—	8.5	—	9.0	ns
t _{G_{P_{TOE/DIS}}}	Input to output global product term output enable/disable	—	10.0	—	10.0	—	10.5	ns
t _{G_{OE/DIS}}	Global OE input to output enable/disable	—	5.5	—	6.0	—	7.0	ns
t _{CW}	Global clock width, high or low	1.8	—	2.0	—	2.8	—	ns
t _{GW}	Global gate width low (for low transparent) or high (for high transparent)	1.8	—	2.0	—	2.8	—	ns
t _{WIR}	Input register clock width, high or low	1.8	—	2.0	—	2.8	—	ns
f _{MAX} ⁴	Clock frequency with internal feedback	—	200	—	200	—	168	MHz
f _{MAX} (Ext.)	clock frequency with external feedback, [1 / (t _S + t _{CO})]	—	150	—	139	—	111	MHz

1. Timing numbers are based on default LVCMOS 1.8 I/O buffers. Use timing adjusters provided to calculate other standards.

Timing v.2.2

2. Measured using standard switching GRP loading of 1 and 1 output switching.

3. Pulse widths and clock widths less than minimum will cause unknown behavior.

4. Standard 16-bit counter using GRP feedback.

Timing Model

The task of determining the timing through the ispMACH 4000 family, like any CPLD, is relatively simple. The timing model provided in Figure 11 shows the specific delay paths. Once the implementation of a given function is determined either conceptually or from the software report file, the delay path of the function can easily be determined from the timing model. The Lattice design tools report the timing delays based on the same timing model for a particular design. Note that the internal timing parameters are given for reference only, and are not tested. The external timing parameters are tested and guaranteed for every device. For more information on the timing model and usage, refer to TN1004, [ispMACH 4000 Timing Model Design and Usage Guidelines](#).

Figure 11. ispMACH 4000 Timing Model

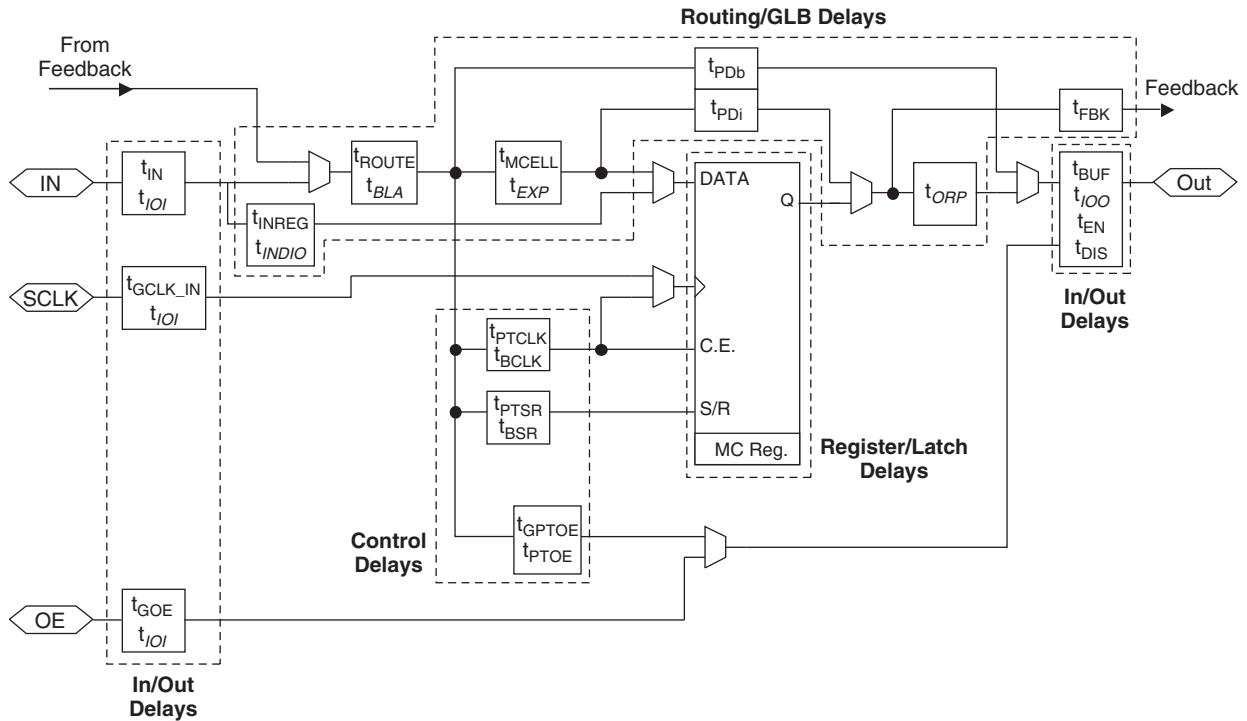

Note: Italicized items are optional delay adders.

ispMACH 4000V/B/C Internal Timing Parameters

Over Recommended Operating Conditions

Parameter	Description	-5		-75		-10		Units
		Min.	Max.	Min.	Max.	Min.	Max.	
In/Out Delays								
t _{IN}	Input Buffer Delay	—	0.95	—	1.50	—	2.00	ns
t _{GOE}	Global OE Pin Delay	—	4.04	—	6.04	—	7.04	ns
t _{GCLK_IN}	Global Clock Input Buffer Delay	—	1.83	—	2.28	—	3.28	ns
t _{BUF}	Delay through Output Buffer	—	1.00	—	1.50	—	1.50	ns
t _{EN}	Output Enable Time	—	0.96	—	0.96	—	0.96	ns
t _{DIS}	Output Disable Time	—	0.96	—	0.96	—	0.96	ns
Routing/GLB Delays								
t _{ROUTE}	Delay through GRP	—	1.51	—	2.26	—	3.26	ns
t _{MCELL}	Macrocell Delay	—	1.05	—	1.45	—	1.95	ns
t _{INREG}	Input Buffer to Macrocell Register Delay	—	0.56	—	0.96	—	1.46	ns
t _{FBK}	Internal Feedback Delay	—	0.00	—	0.00	—	0.00	ns
t _{PDb}	5-PT Bypass Propagation Delay	—	1.54	—	2.24	—	3.24	ns
t _{PDi}	Macrocell Propagation Delay	—	0.94	—	1.24	—	1.74	ns
Register/Latch Delays								
t _S	D-Register Setup Time (Global Clock)	1.32	—	1.57	—	1.57	—	ns
t _{S_PT}	D-Register Setup Time (Product Term Clock)	1.32	—	1.32	—	1.32	—	ns
t _{ST}	T-Register Setup Time (Global Clock)	1.52	—	1.77	—	1.77	—	ns
t _{ST_PT}	T-Register Setup Time (Product Term Clock)	1.32	—	1.32	—	1.32	—	ns
t _H	D-Register Hold Time	1.68	—	2.93	—	3.93	—	ns
t _{HT}	T-Register Hold Time	1.68	—	2.93	—	3.93	—	ns
t _{SIR}	D-Input Register Setup Time (Global Clock)	1.52	—	1.57	—	1.57	—	ns
t _{SIR_PT}	D-Input Register Setup Time (Product Term Clock)	1.45	—	1.45	—	1.45	—	ns
t _{HIR}	D-Input Register Hold Time (Global Clock)	0.68	—	1.18	—	1.18	—	ns
t _{HIR_PT}	D-Input Register Hold Time (Product Term Clock)	0.68	—	1.18	—	1.18	—	ns
t _{COi}	Register Clock to Output/Feedback MUX Time	—	0.52	—	0.67	—	1.17	ns
t _{CES}	Clock Enable Setup Time	2.25	—	2.25	—	2.25	—	ns
t _{CEH}	Clock Enable Hold Time	1.88	—	1.88	—	1.88	—	ns
t _{SL}	Latch Setup Time (Global Clock)	1.32	—	1.57	—	1.57	—	ns
t _{SL_PT}	Latch Setup Time (Product Term Clock)	1.32	—	1.32	—	1.32	—	ns
t _{HL}	Latch Hold Time	1.17	—	1.17	—	1.17	—	ns
t _{GOi}	Latch Gate to Output/Feedback MUX Time	—	0.33	—	0.33	—	0.33	ns
t _{PDLi}	Propagation Delay through Transparent Latch to Output/Feedback MUX	—	0.25	—	0.25	—	0.25	ns
t _{SRI}	Asynchronous Reset or Set to Output/Feedback MUX Delay	0.28	—	0.28	—	0.28	—	ns
t _{SRR}	Asynchronous Reset or Set Recovery Time	1.67	—	1.67	—	1.67	—	ns
Control Delays								
t _{BCLK}	GLB PT Clock Delay	—	1.12	—	1.12	—	0.62	ns
t _{PTCLK}	Macrocell PT Clock Delay	—	0.87	—	0.87	—	0.87	ns
t _{BSR}	GLB PT Set/Reset Delay	—	1.83	—	1.83	—	1.83	ns
t _{PTSR}	Macrocell PT Set/Reset Delay	—	2.51	—	3.41	—	3.41	ns

ispMACH 4000Z Timing Adders (Cont.)¹

Adder Type	Base Parameter	Description	-45		-5		-75		Units
			Min.	Max.	Min.	Max.	Min.	Max.	
Optional Delay Adders									
t _{INDIO}	t _{INREG}	Input register delay	—	1.30	—	1.30	—	1.30	ns
t _{EXP}	t _{MCELL}	Product term expander delay	—	0.45	—	0.45	—	0.50	ns
t _{ORP}	—	Output routing pool delay	—	0.40	—	0.40	—	0.40	ns
t _{BLA}	t _{ROUTE}	Additional block loading adder	—	0.05	—	0.05	—	0.05	ns
t_{IOI} Input Adjusters									
LVTTTL_in	t _{IN} , t _{GCLK_IN} , t _{GOE}	Using LVTTTL standard	—	0.60	—	0.60	—	0.60	ns
LVC MOS33_in	t _{IN} , t _{GCLK_IN} , t _{GOE}	Using LVC MOS 3.3 standard	—	0.60	—	0.60	—	0.60	ns
LVC MOS25_in	t _{IN} , t _{GCLK_IN} , t _{GOE}	Using LVC MOS 2.5 standard	—	0.60	—	0.60	—	0.60	ns
LVC MOS18_in	t _{IN} , t _{GCLK_IN} , t _{GOE}	Using LVC MOS 1.8 standard	—	0.00	—	0.00	—	0.00	ns
PCI_in	t _{IN} , t _{GCLK_IN} , t _{GOE}	Using PCI compatible input	—	0.60	—	0.60	—	0.60	ns
t_{IOO} Output Adjusters									
LVTTTL_out	t _{BUF} , t _{EN} , t _{DIS}	Output configured as TTL buffer	—	0.20	—	0.20	—	0.20	ns
LVC MOS33_out	t _{BUF} , t _{EN} , t _{DIS}	Output configured as 3.3V buffer	—	0.20	—	0.20	—	0.20	ns
LVC MOS25_out	t _{BUF} , t _{EN} , t _{DIS}	Output configured as 2.5V buffer	—	0.10	—	0.10	—	0.10	ns
LVC MOS18_out	t _{BUF} , t _{EN} , t _{DIS}	Output configured as 1.8V buffer	—	0.00	—	0.00	—	0.00	ns
PCI_out	t _{BUF} , t _{EN} , t _{DIS}	Output configured as PCI compatible buffer	—	0.20	—	0.20	—	0.20	ns
Slow Slew	t _{BUF} , t _{EN}	Output configured for slow slew rate	—	1.00	—	1.00	—	1.00	ns

Note: Open drain timing is the same as corresponding LVC MOS timing.

Timing v.2.2

1. Refer to TN1004, [ispMACH 4000 Timing Model Design and Usage Guidelines](#) for information regarding use of these adders.

Boundary Scan Waveforms and Timing Specifications

Symbol	Parameter	Min.	Max.	Units
t_{BTCP}	TCK [BSCAN test] clock cycle	40	—	ns
t_{BTCH}	TCK [BSCAN test] pulse width high	20	—	ns
t_{BTCL}	TCK [BSCAN test] pulse width low	20	—	ns
t_{BTSU}	TCK [BSCAN test] setup time	8	—	ns
t_{BTH}	TCK [BSCAN test] hold time	10	—	ns
t_{BRF}	TCK [BSCAN test] rise and fall time	50	—	mV/ns
t_{BTO}	TAP controller falling edge of clock to valid output	—	10	ns
t_{BTOZ}	TAP controller falling edge of clock to data output disable	—	10	ns
t_{BTVO}	TAP controller falling edge of clock to data output enable	—	10	ns
t_{BTCPSU}	BSCAN test Capture register setup time	8	—	ns
t_{BTCPH}	BSCAN test Capture register hold time	10	—	ns
t_{BTUCO}	BSCAN test Update reg, falling edge of clock to valid output	—	25	ns
t_{BTUOZ}	BSCAN test Update reg, falling edge of clock to output disable	—	25	ns
t_{BTUOV}	BSCAN test Update reg, falling edge of clock to output enable	—	25	ns

Power Consumption

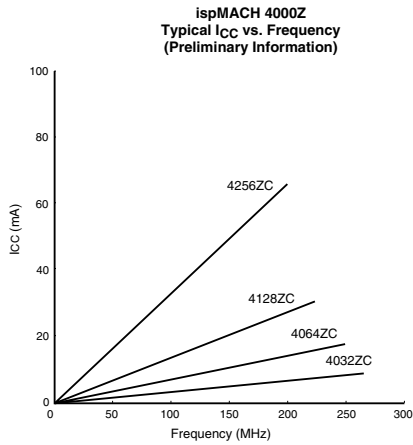

Note: The devices are configured with maximum number of 16-bit counters, typical current at 1.8V, 25°C.

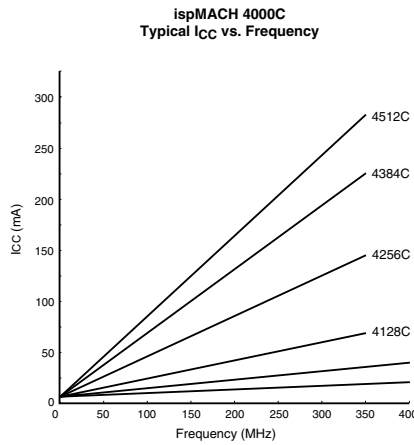

Note: The devices are configured with maximum number of 16-bit counters, typical current at 1.8V, 25°C.

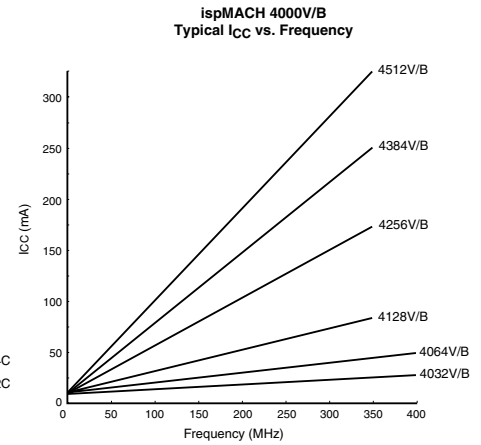

Note: The devices are configured with maximum number of 16-bit counters, typical current at 3.3V, 2.5V, 25°C.

Power Estimation Coefficients¹

Device	A	B
ispMACH 4032V/B	11.3	0.010
ispMACH 4032C	1.3	0.010
ispMACH 4064V/B	11.5	0.010
ispMACH 4064C	1.5	0.010
ispMACH 4128V/B	11.5	0.011
ispMACH 4128C	1.5	0.011
ispMACH 4256V/B	12	0.011
ispMACH 4256C	2	0.011
ispMACH 4384V/B	12.5	0.013
ispMACH 4384C	2.5	0.013
ispMACH 4512V/B	13	0.013
ispMACH 4512C	3	0.013
ispMACH 4032ZC	0.010	0.010
ispMACH 4064ZC	0.011	0.010
ispMACH 4128ZC	0.012	0.010
ispMACH 4256ZC	0.013	0.010

1. For further information about the use of these coefficients, refer to TN1005, [Power Estimation in ispMACH 4000V/B/C/Z Devices](#).

**ispMACH 4032V/B/C/Z and 4064V/B/C/Z Logic Signal Connections:
48-Pin TQFP (Cont.)**

Pin Number	Bank Number	ispMACH 4032V/B/C/Z		ispMACH 4064V/B/C		ispMACH 4064Z	
		GLB/MC/Pad	ORP	GLB/MC/Pad	ORP	GLB/MC/Pad	ORP
33	1	B10	B [^] 10	D4	D [^] 2	D10	D [^] 5
34	1	B11	B [^] 11	D6	D [^] 3	D8	D [^] 4
35	-	TDO	-	TDO	-	TDO	-
36	-	VCC	-	VCC	-	VCC	-
37	-	GND	-	GND	-	GND	-
38	1	B12	B [^] 12	D8	D [^] 4	D6	D [^] 3
39	1	B13	B [^] 13	D10	D [^] 5	D4	D [^] 2
40	1	B14	B [^] 14	D12	D [^] 6	D2	D [^] 1
41	1	B15/GOE1	B [^] 15	D14/GOE1	D [^] 7	D0/GOE1	D [^] 0
42	1	CLK3/I	-	CLK3/I	-	CLK3/I	-
43	0	CLK0/I	-	CLK0/I	-	CLK0/I	-
44	0	A0/GOE0	A [^] 0	A0/GOE0	A [^] 0	A0/GOE0	A [^] 0
45	0	A1	A [^] 1	A2	A [^] 1	A1	A [^] 1
46	0	A2	A [^] 2	A4	A [^] 2	A2	A [^] 2
47	0	A3	A [^] 3	A6	A [^] 3	A4	A [^] 3
48	0	A4	A [^] 4	A8	A [^] 4	A6	A [^] 4

ispMACH 4032Z and 4064Z Logic Signal Connections: 56-Ball csBGA

Ball Number	Bank Number	ispMACH 4032Z		ispMACH 4064Z	
		GLB/MC/Pad	ORP	GLB/MC/Pad	ORP
B1	-	TDI	-	TDI	-
C3	0	A5	A [^] 5	A8	A [^] 5
C1	0	A6	A [^] 6	A10	A [^] 6
D1	0	A7	A [^] 7	A11	A [^] 7
D3	0	GND (Bank 0)	-	GND (Bank 0)	-
E3	0	NC ¹	-	I ¹	-
E1	0	NC ¹	-	I ¹	-
F3	0	VCCO (Bank 0)	-	VCCO (Bank 0)	-
F1	0	A8	A [^] 8	B15	B [^] 7
G3	0	A9	A [^] 9	B12	B [^] 6
G1	0	A10	A [^] 10	B10	B [^] 5
H1	0	A11	A [^] 11	B8	B [^] 4
J1	0	NC	-	I	-
K1	-	TCK	-	TCK	-
K2	-	VCC	-	VCC	-
H3	-	GND	-	GND	-
K3	-	NC ¹	-	I ¹	-
K4	0	A12	A [^] 12	B6	B [^] 3
H4	0	A13	A [^] 13	B4	B [^] 2
H5	0	A14	A [^] 14	B2	B [^] 1

**ispMACH 4064Z, 4128Z and 4256Z Logic Signal Connections:
132-Ball csBGA (Cont.)**

Ball Number	Bank Number	ispMACH 4064Z		ispMACH 4128Z		ispMACH 4256Z	
		GLB/MC/Pad	ORP	GLB/MC/Pad	ORP	GLB/MC/Pad	ORP
E3	0	NC	-	B8	B^6	D12	D^6
F2	0	A12	A^12	B9	B^7	D10	D^5
F1	0	A13	A^13	B10	B^8	D8	D^4
F3	0	A14	A^14	B12	B^9	D6	D^3
G1	0	A15	A^15	B13	B^10	D4	D^2
G2	0	I	-	B14	B^11	D2	D^1
G3	0	VCCO (Bank 0)	-	VCCO (Bank 0)	-	VCCO (Bank 0)	-
H2	0	NC	-	C14	C^11	E2	E^1
H1	0	B15	B^15	C13	C^10	E4	E^2
H3	0	B14	B^14	C12	C^9	E6	E^3
J1	0	B13	B^13	C10	C^8	E8	E^4
J2	0	B12	B^12	C9	C^7	E10	E^5
J3	0	NC	-	C8	C^6	E12	E^6
K2	0	GND (Bank 0)	-	GND (Bank 0)	-	GND (Bank 0)	-
K1	0	NC	-	C6	C^5	F2	F^1
K3	0	B11	B^11	C5	C^4	F4	F^2
L2	0	B10	B^10	C4	C^3	F6	F^3
L1	0	B9	B^9	C2	C^2	F8	F^4
L3	0	B8	B^8	C1	C^1	F10	F^5
M1	0	I	-	C0	C^0	F12	F^6
M2	0	NC	-	VCCO (Bank 0)	-	VCCO (Bank 0)	-
N1	-	TCK	-	TCK	-	TCK	-
P1	-	VCC	-	VCC	-	VCC	-
P2	-	GND	-	GND	-	GND	-
N2	0	I	-	D14	D^11	G12	G^6
P3	0	B7	B^7	D13	D^10	G10	G^5
M3	0	B6	B^6	D12	D^9	G8	G^4
N3	0	B5	B^5	D10	D^8	G6	G^3
P4	0	B4	B^4	D9	D^7	G4	G^2
M4	0	NC	-	D8	D^6	G2	G^1
N4	0	GND (Bank 0)	-	GND (Bank 0)	-	GND (Bank 0)	-
P5	0	VCCO (Bank 0)	-	VCCO (Bank 0)	-	VCCO (Bank 0)	-
N5	0	NC	-	D6	D^5	H12	H^6
M5	0	B3	B^3	D5	D^4	H10	H^5
N6	0	B2	B^2	D4	D^3	H8	H^4
P6	0	B1	B^1	D2	D^2	H6	H^3
M6	0	B0	B^0	D1	D^1	H4	H^2
P7	0	NC	-	D0	D^0	H2	H^1
N7	0	CLK1/I	-	CLK1/I	-	CLK1/I	-
M7	1	CLK2/I	-	CLK2/I	-	CLK2/I	-
N8	-	VCC	-	VCC	-	VCC	-

ispMACH 4128V and 4256V Logic Signal Connections: 144-Pin TQFP

Pin Number	Bank Number	ispMACH 4128V		ispMACH 4256V	
		GLB/MC/Pad	ORP	GLB/MC/Pad	ORP
1	-	GND	-	GND	-
2	-	TDI	-	TDI	-
3	0	VCCO (Bank 0)	-	VCCO (Bank 0)	-
4	0	B0	B^0	C12	C^6
5	0	B1	B^1	C10	C^5
6	0	B2	B^2	C8	C^4
7	0	B4	B^3	C6	C^3
8	0	B5	B^4	C4	C^2
9	0	B6	B^5	C2	C^1
10	0	GND (Bank 0)	-	GND (Bank 0)	-
11	0	B8	B^6	D14	D^7
12	0	B9	B^7	D12	D^6
13	0	B10	B^8	D10	D^5
14	0	B12	B^9	D8	D^4
15	0	B13	B^10	D6	D^3
16	0	B14	B^11	D4	D^2
17	-	NC ²	-	I ²	-
18	0	GND (Bank 0) ¹	-	NC ¹	-
19	0	VCCO (Bank 0)	-	VCCO (Bank 0)	-
20	0	NC ²	-	I ²	-
21	0	C14	C^11	E2	E^1
22	0	C13	C^10	E4	E^2
23	0	C12	C^9	E6	E^3
24	0	C10	C^8	E8	E^4
25	0	C9	C^7	E10	E^5
26	0	C8	C^6	E12	E^6
27	0	GND (Bank 0)	-	GND (Bank 0)	-
28	0	C6	C^5	F2	F^1
29	0	C5	C^4	F4	F^2
30	0	C4	C^3	F6	F^3
31	0	C2	C^2	F8	F^4
32	0	C1	C^1	F10	F^5
33	0	C0	C^0	F12	F^6
34	0	VCCO (Bank 0)	-	VCCO (Bank 0)	-
35	-	TCK	-	TCK	-
36	-	VCC	-	VCC	-
37	-	GND	-	GND	-
38	0	NC ²	-	I ²	-
39	0	D14	D^11	G12	G^6
40	0	D13	D^10	G10	G^5
41	0	D12	D^9	G8	G^4
42	0	D10	D^8	G6	G^3

**ispMACH 4256V/B/C/Z, 4384V/B/C, 4512V/B/C, Logic Signal Connections:
176-Pin TQFP (Cont.)**

Pin Number	Bank Number	ispMACH 4256V/B/C/Z		ispMACH 4384V/B/C		ispMACH 4512V/B/C	
		GLB/MC/Pad	ORP	GLB/MC/Pad	ORP	GLB/MC/Pad	ORP
19	0	D4	D ²	E4	E ²	G4	G ²
20	0	D2	D ¹	E2	E ¹	G2	G ¹
21	0	D0	D ⁰	E0	E ⁰	G0	G ⁰
22	0	VCCO (Bank 0)	-	VCCO (Bank 0)	-	VCCO (Bank 0)	-
23	0	E0	E ⁰	H0	H ⁰	J0	J ⁰
24	0	E2	E ¹	H2	H ¹	J2	J ¹
25	0	E4	E ²	H4	H ²	J4	J ²
26	0	E6	E ³	H6	H ³	J6	J ³
27	0	E8	E ⁴	H8	H ⁴	J8	J ⁴
28	0	E10	E ⁵	H10	H ⁵	J10	J ⁵
29	0	E12	E ⁶	H12	H ⁶	J12	J ⁶
30	0	E14	E ⁷	H14	H ⁷	J14	J ⁷
31	0	GND (Bank 0)	-	GND (Bank 0)	-	GND (Bank 0)	-
32	0	F0	F ⁰	J0	J ⁰	N0	N ⁰
33	0	F2	F ¹	J2	J ¹	N2	N ¹
34	0	F4	F ²	J4	J ²	N4	N ²
35	0	F6	F ³	J6	J ³	N6	N ³
36	0	F8	F ⁴	J8	J ⁴	N8	N ⁴
37	0	F10	F ⁵	J10	J ⁵	N10	N ⁵
38	0	F12	F ⁶	J12	J ⁶	N12	N ⁶
39	0	F14	F ⁷	J14	J ⁷	N14	N ⁷
40	0	VCCO (Bank 0)	-	VCCO (Bank 0)	-	VCCO (Bank 0)	-
41	-	TCK	-	TCK	-	TCK	-
42	-	VCC	-	VCC	-	VCC	-
43	-	NC	-	NC	-	NC	-
44	-	NC	-	NC	-	NC	-
45	-	NC	-	NC	-	NC	-
46	-	GND	-	GND (Bank 0)	-	GND	-
47	0	G14	G ⁷	K14	K ⁷	O14	O ⁷
48	0	G12	G ⁶	K12	K ⁶	O12	O ⁶
49	0	G10	G ⁵	K10	K ⁵	O10	O ⁵
50	0	G8	G ⁴	K8	K ⁴	O8	O ⁴
51	0	G6	G ³	K6	K ³	O6	O ³
52	0	G4	G ²	K4	K ²	O4	O ²
53	0	G2	G ¹	K2	K ¹	O2	O ¹
54	0	G0	G ⁰	K0	K ⁰	O0	O ⁰
55	0	GND (Bank 0)	-	GND (Bank 0)	-	GND (Bank 0)	-
56	0	VCCO (Bank 0)	-	VCCO (Bank 0)	-	VCCO (Bank 0)	-
57	0	H14	H ⁷	L14	L ⁷	P14	P ⁷
58	0	H12	H ⁶	L12	L ⁶	P12	P ⁶
59	0	H10	H ⁵	L10	L ⁵	P10	P ⁵

**ispMACH 4256V/B/C, 4384V/B/C, 4512V/B/C Logic Signal Connections:
256-Ball ftBGA/fpBGA (Cont.)**

Ball Number	I/O Bank	ispMACH 4256V/B/C 128-I/O		ispMACH 4256V/B/C 160-I/O		ispMACH 4384V/B/C		ispMACH 4512V/B/C	
		GLB/MC/Pad	ORP	GLB/MC/Pad	ORP	GLB/MC/Pad	ORP	GLB/MC/Pad	ORP
J6	0	E14	E ⁷	E10	E ⁷	H14	H ⁷	J14	J ⁷
K3	0	NC	-	E12	E ⁸	G0	G ⁰	I0	I ⁰
K4	0	NC	-	E14	E ⁹	G2	G ¹	I4	I ¹
L1	0	NC	-	NC	-	I14	I ⁷	K0	K ⁰
L2	0	NC	-	NC	-	I12	I ⁶	K2	K ¹
M1	0	NC	-	NC	-	NC	-	K4	K ²
-	0	GND (Bank 0)	-	GND (Bank 0)	-	GND (Bank 0)	-	GND (Bank 0)	-
-	0	-	-	VCCO (Bank 0)	-	VCCO (Bank 0)	-	VCCO (Bank 0)	-
M2	0	NC	-	NC	-	NC	-	K6	K ³
N1	0	NC	-	NC	-	I10	I ⁵	K8	K ⁴
M3	0	NC	-	NC	-	I8	I ⁴	K10	K ⁵
M4	0	NC	-	F0	F ⁰	G4	G ²	I8	I ²
N2	0	NC	-	F1	F ¹	G6	G ³	I12	I ³
K5	0	F0	F ⁰	F2	F ²	J0	J ⁰	N0	N ⁰
P1	0	F2	F ¹	F4	F ³	J2	J ¹	N2	N ¹
K6	0	F4	F ²	F6	F ⁴	J4	J ²	N4	N ²
N3	0	F6	F ³	F8	F ⁵	J6	J ³	N6	N ³
L5	0	F8	F ⁴	F9	F ⁶	J8	J ⁴	N8	N ⁴
P2	0	F10	F ⁵	F10	F ⁷	J10	J ⁵	N10	N ⁵
L6	0	F12	F ⁶	F12	F ⁸	J12	J ⁶	N12	N ⁶
R1	0	F14	F ⁷	F14	F ⁹	J14	J ⁷	N14	N ⁷
-	0	VCCO (Bank 0)	-	VCCO (Bank 0)	-	VCCO (Bank 0)	-	VCCO (Bank 0)	-
P3	-	TCK	-	TCK	-	TCK	-	TCK	-
-	-	VCC	-	VCC	-	VCC	-	VCC	-
-	-	GND	-	GND	-	GND	-	GND	-
-	0	-	-	GND (Bank 0)	-	GND (Bank 0)	-	GND (Bank 0)	-
T2	0	NC	-	G14	G ⁹	I6	I ³	K12	K ⁶
M5	0	NC	-	G12	G ⁸	I4	I ²	K14	K ⁷
N4	0	G14	G ⁷	G10	G ⁷	K14	K ⁷	O14	O ⁷
T3	0	G12	G ⁶	G9	G ⁶	K12	K ⁶	O12	O ⁶
R3	0	G10	G ⁵	G8	G ⁵	K10	K ⁵	O10	O ⁵
M6	0	G8	G ⁴	G6	G ⁴	K8	K ⁴	O8	O ⁴
P4	0	G6	G ³	G4	G ³	K6	K ³	O6	O ³
L7	0	G4	G ²	G2	G ²	K4	K ²	O4	O ²
N5	0	G2	G ¹	G1	G ¹	K2	K ¹	O2	O ¹
M7	0	G0	G ⁰	G0	G ⁰	K0	K ⁰	O0	O ⁰
P5	0	NC	-	NC	-	G8	G ⁴	M0	M ⁰
R4	0	NC	-	NC	-	G10	G ⁵	M4	M ¹
T4	0	NC	-	NC	-	NC	-	L0	L ⁰
-	0	GND (Bank 0)	-	GND (Bank 0)	-	GND (Bank 0)	-	GND (Bank 0)	-
-	0	VCCO (Bank 0)	-	VCCO (Bank 0)	-	VCCO (Bank 0)	-	VCCO (Bank 0)	-

**ispMACH 4256V/B/C, 4384V/B/C, 4512V/B/C Logic Signal Connections:
256-Ball ftBGA/fpBGA (Cont.)**

Ball Number	I/O Bank	ispMACH 4256V/B/C 128-I/O		ispMACH 4256V/B/C 160-I/O		ispMACH 4384V/B/C		ispMACH 4512V/B/C	
		GLB/MC/Pad	ORP	GLB/MC/Pad	ORP	GLB/MC/Pad	ORP	GLB/MC/Pad	ORP
H15	1	M2	M^1	M1	M^1	DX2	DX^1	JX2	JX^1
H14	1	M4	M^2	M2	M^2	DX4	DX^2	JX4	JX^2
H13	1	M6	M^3	M4	M^3	DX6	DX^3	JX6	JX^3
G16	1	M8	M^4	M6	M^4	DX8	DX^4	JX8	JX^4
H12	1	M10	M^5	M8	M^5	DX10	DX^5	JX10	JX^5
G15	1	M12	M^6	M9	M^6	DX12	DX^6	JX12	JX^6
H11	1	M14	M^7	M10	M^7	DX14	DX^7	JX14	JX^7
F16	1	NC	-	M12	M^8	CX0	CX^0	IX0	IX^0
G13	1	NC	-	M14	M^9	CX2	CX^1	IX4	IX^1
G14	1	NC	-	NC	-	EX14	EX^7	KX0	KX^0
F15	1	NC	-	NC	-	EX12	EX^6	KX2	KX^1
E16	1	NC	-	NC	-	NC	-	KX4	KX^2
-	1	GND (Bank 1)	-	GND (Bank 1)	-	GND (Bank 1)	-	GND (Bank 1)	-
-	1	-	-	VCCO (Bank 1)	-	VCCO (Bank 1)	-	VCCO (Bank 1)	-
E15	1	NC	-	NC	-	NC	-	KX6	KX^3
G12	1	NC	-	NC	-	EX10	EX^5	KX8	KX^4
E13	1	NC	-	NC	-	EX8	EX^4	KX10	KX^5
D16	1	NC	-	N0	N^0	CX4	CX^2	IX8	IX^2
E14	1	NC	-	N1	N^1	CX6	CX^3	IX12	IX^3
G11	1	N0	N^0	N2	N^2	FX0	FX^0	NX0	NX^0
D15	1	N2	N^1	N4	N^3	FX2	FX^1	NX2	NX^1
F11	1	N4	N^2	N6	N^4	FX4	FX^2	NX4	NX^2
C16	1	N6	N^3	N8	N^5	FX6	FX^3	NX6	NX^3
F12	1	N8	N^4	N9	N^6	FX8	FX^4	NX8	NX^4
D14	1	N10	N^5	N10	N^7	FX10	FX^5	NX10	NX^5
C15	1	N12	N^6	N12	N^8	FX12	FX^6	NX12	NX^6
B16	1	N14	N^7	N14	N^9	FX14	FX^7	NX14	NX^7
-	1	VCCO (Bank 1)	-	VCCO (Bank 1)	-	VCCO (Bank 1)	-	VCCO (Bank 1)	-
C14	-	TDO	-	TDO	-	TDO	-	TDO	-
-	-	VCC	-	VCC	-	VCC	-	VCC	-
-	-	GND	-	GND	-	GND	-	GND	-
-	1	-	-	GND (Bank 1)	-	GND (Bank 1)	-	GND (Bank 1)	-
A15	1	NC	-	NC	-	EX6	EX^3	KX12	KX^6
B14	1	NC	-	NC	-	EX4	EX^2	KX14	KX^7
E12	1	O14	O^7	O14	O^9	GX14	GX^7	OX14	OX^7
A14	1	O12	O^6	O12	O^8	GX12	GX^6	OX12	OX^6
C13	1	O10	O^5	O10	O^7	GX10	GX^5	OX10	OX^5
D13	1	O8	O^4	O9	O^6	GX8	GX^4	OX8	OX^4
E11	1	O6	O^3	O8	O^5	GX6	GX^3	OX6	OX^3
B13	1	O4	O^2	O6	O^4	GX4	GX^2	OX4	OX^2
F10	1	O2	O^1	O4	O^3	GX2	GX^1	OX2	OX^1

ispMACH 4000C (1.8V) Commercial Devices (Cont.)

Device	Part Number	Macrocells	Voltage	t _{PD}	Package	Pin/Ball Count	I/O	Grade
LC4128C	LC4128C-27T128C	128	1.8	2.7	TQFP	128	92	C
	LC4128C-5T128C	128	1.8	5	TQFP	128	92	C
	LC4128C-75T128C	128	1.8	7.5	TQFP	128	92	C
	LC4128C-27T100C	128	1.8	2.7	TQFP	100	64	C
	LC4128C-5T100C	128	1.8	5	TQFP	100	64	C
	LC4128C-75T100C	128	1.8	7.5	TQFP	100	64	C
LC4256C	LC4256C-3FT256AC	256	1.8	3	ftBGA	256	128	C
	LC4256C-5FT256AC	256	1.8	5	ftBGA	256	128	C
	LC4256C-75FT256AC	256	1.8	7.5	ftBGA	256	128	C
	LC4256C-3FT256BC	256	1.8	3	ftBGA	256	160	C
	LC4256C-5FT256BC	256	1.8	5	ftBGA	256	160	C
	LC4256C-75FT256BC	256	1.8	7.5	ftBGA	256	160	C
	LC4256C-3F256AC ¹	256	1.8	3	fpBGA	256	128	C
	LC4256C-5F256AC ¹	256	1.8	5	fpBGA	256	128	C
	LC4256C-75F256AC ¹	256	1.8	7.5	fpBGA	256	128	C
	LC4256C-3F256BC ¹	256	1.8	3	fpBGA	256	160	C
	LC4256C-5F256BC ¹	256	1.8	5	fpBGA	256	160	C
	LC4256C-75F256BC ¹	256	1.8	7.5	fpBGA	256	160	C
	LC4256C-3T176C	256	1.8	3	TQFP	176	128	C
	LC4256C-5T176C	256	1.8	5	TQFP	176	128	C
	LC4256C-75T176C	256	1.8	7.5	TQFP	176	128	C
	LC4256C-3T100C	256	1.8	3	TQFP	100	64	C
LC4256C-5T100C	256	1.8	5	TQFP	100	64	C	
LC4256C-75T100C	256	1.8	7.5	TQFP	100	64	C	
LC4384C	LC4384C-35FT256C	384	1.8	3.5	ftBGA	256	192	C
	LC4384C-5FT256C	384	1.8	5	ftBGA	256	192	C
	LC4384C-75FT256C	384	1.8	7.5	ftBGA	256	192	C
	LC4384C-35F256C ¹	384	1.8	3.5	fpBGA	256	192	C
	LC4384C-5F256C ¹	384	1.8	5	fpBGA	256	192	C
	LC4384C-75F256C ¹	384	1.8	7.5	fpBGA	256	192	C
	LC4384C-35T176C	384	1.8	3.5	TQFP	176	128	C
	LC4384C-5T176C	384	1.8	5	TQFP	176	128	C
	LC4384C-75T176C	384	1.8	7.5	TQFP	176	128	C
LC4512C	LC4512C-35FT256C	512	1.8	3.5	ftBGA	256	208	C
	LC4512C-5FT256C	512	1.8	5	ftBGA	256	208	C
	LC4512C-75FT256C	512	1.8	7.5	ftBGA	256	208	C
	LC4512C-35F256C ¹	512	1.8	3.5	fpBGA	256	208	C
	LC4512C-5F256C ¹	512	1.8	5	fpBGA	256	208	C
	LC4512C-75F256C ¹	512	1.8	7.5	fpBGA	256	208	C
	LC4512C-35T176C	512	1.8	3.5	TQFP	176	128	C
	LC4512C-5T176C	512	1.8	5	TQFP	176	128	C
LC4512C-75T176C	512	1.8	7.5	TQFP	176	128	C	

1. Use ftBGA package. fpBGA package devices have been discontinued via PCN#14A-07.

ispMACH 4000V (3.3V) Extended Temperature Devices

Device	Part Number	Macrocells	Voltage	t _{PD}	Package	Pin/Ball Count	I/O	Grade
LC4032V	LC4032V-75T48E	32	3.3	7.5	TQFP	48	32	E
	LC4032V-75T44E	32	3.3	7.5	TQFP	44	30	E
LC4064V	LC4064V-75T100E	64	3.3	7.5	TQFP	100	64	E
	LC4064V-75T48E	64	3.3	7.5	TQFP	48	32	E
	LC4064V-75T44E	64	3.3	7.5	TQFP	44	30	E
LC4128V	LC4128V-75T144E	128	3.3	7.5	TQFP	144	96	E
	LC4128V-75T128E	128	3.3	7.5	TQFP	128	92	E
	LC4128V-75T100E	128	3.3	7.5	TQFP	100	64	E
LC4256V	LC4256V-75T176E	256	3.3	7.5	TQFP	176	128	E
	LC4256V-75T144E	256	3.3	7.5	TQFP	144	96	E
	LC4256V-75T100E	256	3.3	7.5	TQFP	100	64	E