



Welcome to [E-XFL.COM](https://www.e-xfl.com)

Understanding [Embedded - CPLDs \(Complex Programmable Logic Devices\)](#)

Embedded - CPLDs, or Complex Programmable Logic Devices, are highly versatile digital logic devices used in electronic systems. These programmable components are designed to perform complex logical operations and can be customized for specific applications. Unlike fixed-function ICs, CPLDs offer the flexibility to reprogram their configuration, making them an ideal choice for various embedded systems. They consist of a set of logic gates and programmable interconnects, allowing designers to implement complex logic circuits without needing custom hardware.

Applications of Embedded - CPLDs

Details

Product Status	Obsolete
Programmable Type	In System Programmable
Delay Time tpd(1) Max	5 ns
Voltage Supply - Internal	2.3V ~ 2.7V
Number of Logic Elements/Blocks	16
Number of Macrocells	256
Number of Gates	-
Number of I/O	128
Operating Temperature	0°C ~ 90°C (TJ)
Mounting Type	Surface Mount
Package / Case	176-LQFP
Supplier Device Package	176-TQFP (24x24)
Purchase URL	https://www.e-xfl.com/product-detail/lattice-semiconductor/lc4256b-5t176c

Table 2. ispMACH 4000Z Family Selection Guide

	ispMACH 4032ZC	ispMACH 4064ZC	ispMACH 4128ZC	ispMACH 4256ZC
Macrocells	32	64	128	256
I/O + Dedicated Inputs	32+4/32+4	32+4/32+12/ 64+10/64+10	64+10/96+4	64+10/96+6/ 128+4
t _{PD} (ns)	3.5	3.7	4.2	4.5
t _S (ns)	2.2	2.5	2.7	2.9
t _{CO} (ns)	3.0	3.2	3.5	3.8
f _{MAX} (MHz)	267	250	220	200
Supply Voltage (V)	1.8	1.8	1.8	1.8
Max. Standby I _{CC} (μA)	20	25	35	55
Pins/Package	48 TQFP 56 csBGA	48 TQFP 56 csBGA 100 TQFP 132 csBGA	100 TQFP 132csBGA	100 TQFP 132 csBGA 176 TQFP

ispMACH 4000 Introduction

The high performance ispMACH 4000 family from Lattice offers a SuperFAST CPLD solution. The family is a blend of Lattice's two most popular architectures: the ispLSI® 2000 and ispMACH 4A. Retaining the best of both families, the ispMACH 4000 architecture focuses on significant innovations to combine the highest performance with low power in a flexible CPLD family.

The ispMACH 4000 combines high speed and low power with the flexibility needed for ease of design. With its robust Global Routing Pool and Output Routing Pool, this family delivers excellent First-Time-Fit, timing predictability, routing, pin-out retention and density migration.

The ispMACH 4000 family offers densities ranging from 32 to 512 macrocells. There are multiple density-I/O combinations in Thin Quad Flat Pack (TQFP), Chip Scale BGA (csBGA) and Fine Pitch Thin BGA (ftBGA) packages ranging from 44 to 256 pins/balls. Table 1 shows the macrocell, package and I/O options, along with other key parameters.

The ispMACH 4000 family has enhanced system integration capabilities. It supports 3.3V (4000V), 2.5V (4000B) and 1.8V (4000C/Z) supply voltages and 3.3V, 2.5V and 1.8V interface voltages. Additionally, inputs can be safely driven up to 5.5V when an I/O bank is configured for 3.3V operation, making this family 5V tolerant. The ispMACH 4000 also offers enhanced I/O features such as slew rate control, PCI compatibility, bus-keeper latches, pull-up resistors, pull-down resistors, open drain outputs and hot socketing. The ispMACH 4000 family members are 3.3V/2.5V/1.8V in-system programmable through the IEEE Standard 1532 interface. IEEE Standard 1149.1 boundary scan testing capability also allows product testing on automated test equipment. The 1532 interface signals TCK, TMS, TDI and TDO are referenced to V_{CC} (logic core).

Overview

The ispMACH 4000 devices consist of multiple 36-input, 16-macrocell Generic Logic Blocks (GLBs) interconnected by a Global Routing Pool (GRP). Output Routing Pools (ORPs) connect the GLBs to the I/O Blocks (IOBs), which contain multiple I/O cells. This architecture is shown in Figure 1.

Table 7. ORP Combinations for I/O Blocks with 16 I/Os

I/O Cell	Available Macrocells
I/O 0	M0, M1, M2, M3, M4, M5, M6, M7
I/O 1	M1, M2, M3, M4, M5, M6, M7, M8
I/O 2	M2, M3, M4, M5, M6, M7, M8, M9
I/O 3	M3, M4, M5, M6, M7, M8, M9, M10
I/O 4	M4, M5, M6, M7, M8, M9, M10, M11
I/O 5	M5, M6, M7, M8, M9, M10, M11, M12
I/O 6	M6, M7, M8, M9, M10, M11, M12, M13
I/O 7	M7, M8, M9, M10, M11, M12, M13, M14
I/O 8	M8, M9, M10, M11, M12, M13, M14, M15
I/O 9	M9, M10, M11, M12, M13, M14, M15, M0
I/O 10	M10, M11, M12, M13, M14, M15, M0, M1
I/O 11	M11, M12, M13, M14, M15, M0, M1, M2
I/O 12	M12, M13, M14, M15, M0, M1, M2, M3
I/O 13	M13, M14, M15, M0, M1, M2, M3, M4
I/O 14	M14, M15, M0, M1, M2, M3, M4, M5
I/O 15	M15, M0, M1, M2, M3, M4, M5, M6

Table 8. ORP Combinations for I/O Blocks with 4 I/Os

I/O Cell	Available Macrocells
I/O 0	M0, M1, M2, M3, M4, M5, M6, M7
I/O 1	M4, M5, M6, M7, M8, M9, M10, M11
I/O 2	M8, M9, M10, M11, M12, M13, M14, M15
I/O 3	M12, M13, M14, M15, M0, M1, M2, M3

Table 9. ORP Combinations for I/O Blocks with 10 I/Os

I/O Cell	Available Macrocells
I/O 0	M0, M1, M2, M3, M4, M5, M6, M7
I/O 1	M2, M3, M4, M5, M6, M7, M8, M9
I/O 2	M4, M5, M6, M7, M8, M9, M10, M11
I/O 3	M6, M7, M8, M9, M10, M11, M12, M13
I/O 4	M8, M9, M10, M11, M12, M13, M14, M15
I/O 5	M10, M11, M12, M13, M14, M15, M0, M1
I/O 6	M12, M13, M14, M15, M0, M1, M2, M3
I/O 7	M14, M15, M0, M1, M2, M3, M4, M5
I/O 8	M2, M3, M4, M5, M6, M7, M8, M9
I/O 9	M10, M11, M12, M13, M14, M15, M0, M1

Table 10. ORP Combinations for I/O Blocks with 12 I/Os

I/O Cell	Available Macrocells
I/O 0	M0, M1, M2, M3, M4, M5, M6, M7
I/O 1	M1, M2, M3, M4, M5, M6, M7, M8
I/O 2	M2, M3, M4, M5, M6, M7, M8, M9
I/O 3	M4, M5, M6, M7, M8, M9, M10, M11
I/O 4	M5, M6, M7, M8, M9, M10, M11, M12
I/O 5	M6, M7, M8, M9, M10, M11, M12, M13
I/O 6	M8, M9, M10, M11, M12, M13, M14, M15
I/O 7	M9, M10, M11, M12, M13, M14, M15, M0
I/O 8	M10, M11, M12, M13, M14, M15, M0, M1
I/O 9	M12, M13, M14, M15, M0, M1, M2, M3
I/O 10	M13, M14, M15, M0, M1, M2, M3, M4
I/O 11	M14, M15, M0, M1, M2, M3, M4, M5

ORP Bypass and Fast Output Multiplexers

The ORP bypass and fast-path output multiplexer is a 4:1 multiplexer and allows the 5-PT fast path to bypass the ORP and be connected directly to the pin with either the regular output or the inverted output. This multiplexer also allows the register output to bypass the ORP to achieve faster t_{CO} .

Output Enable Routing Multiplexers

The OE Routing Pool provides the corresponding local output enable (OE) product term to the I/O cell.

I/O Cell

The I/O cell contains the following programmable elements: output buffer, input buffer, OE multiplexer and bus maintenance circuitry. Figure 8 details the I/O cell.

Figure 8. I/O Cell

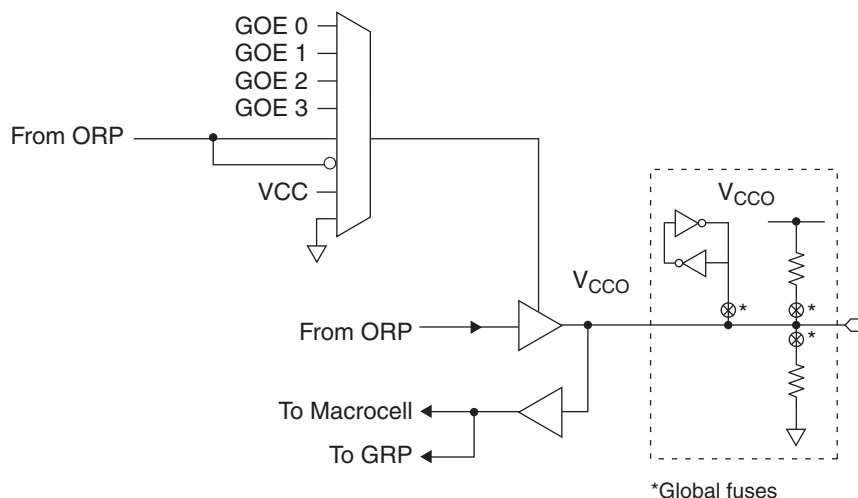

Each output supports a variety of output standards dependent on the V_{CC0} supplied to its I/O bank. Outputs can also be configured for open drain operation. Each input can be programmed to support a variety of standards, independent of the V_{CC0} supplied to its I/O bank. The I/O standards supported are:

- LVTTTL
- LVC MOS 3.3
- LVC MOS 2.5
- LVC MOS 1.8
- 3.3V PCI Compatible

All of the I/Os and dedicated inputs have the capability to provide a bus-keeper latch, Pull-up Resistor or Pull-down Resistor. A fourth option is to provide none of these. The selection is done on a global basis. The default in both hardware and software is such that when the device is erased or if the user does not specify, the input structure is configured to be a Pull-up Resistor.

Each ispMACH 4000 device I/O has an individually programmable output slew rate control bit. Each output can be individually configured for fast slew or slow slew. The typical edge rate difference between fast and slow slew setting is 20%. For high-speed designs with long, unterminated traces, the slow-slew rate will introduce fewer reflections, less noise and keep ground bounce to a minimum. For designs with short traces or well terminated lines, the fast slew rate can be used to achieve the highest speed.

Global OE Generation

Most ispMACH 4000 family devices have a 4-bit wide Global OE Bus, except the ispMACH 4032 device that has a 2-bit wide Global OE Bus. This bus is derived from a 4-bit internal global OE PT bus and two dual purpose I/O or GOE pins. Each signal that drives the bus can optionally be inverted.

Each GLB has a block-level OE PT that connects to all bits of the Global OE PT bus with four fuses. Hence, for a 256-macrocell device (with 16 blocks), each line of the bus is driven from 16 OE product terms. Figures 9 and 10 show a graphical representation of the global OE generation.

Figure 9. Global OE Generation for All Devices Except ispMACH 4032

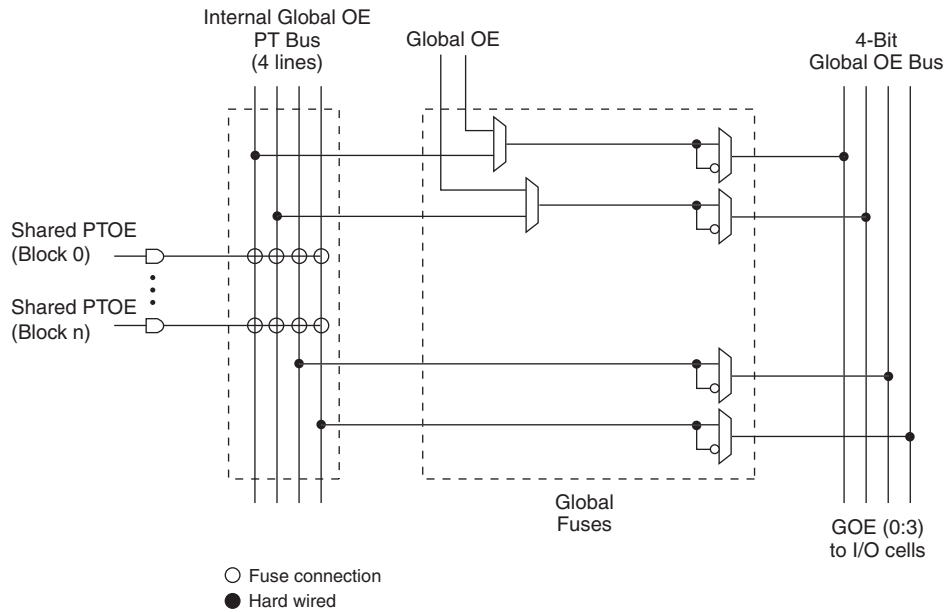

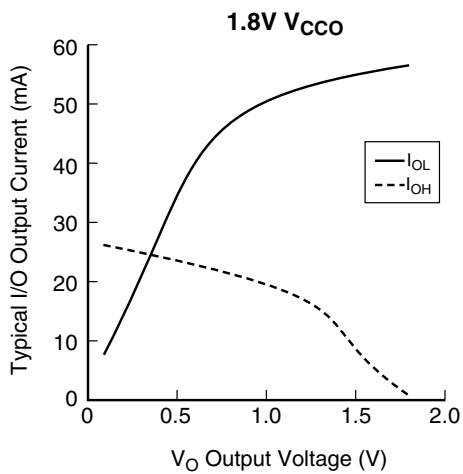
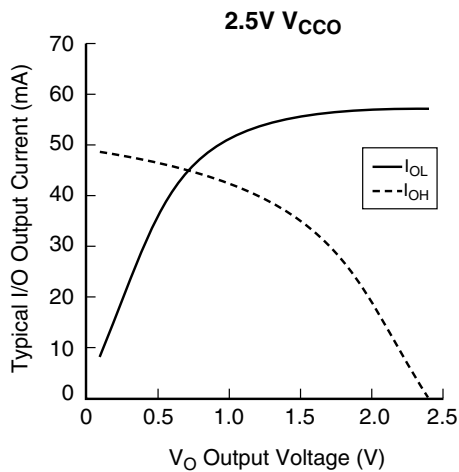
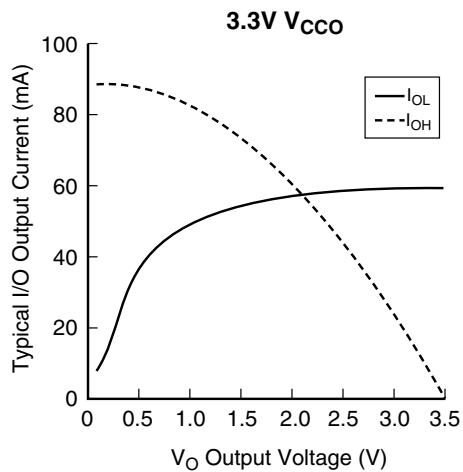

Timing Model

The task of determining the timing through the ispMACH 4000 family, like any CPLD, is relatively simple. The timing model provided in Figure 11 shows the specific delay paths. Once the implementation of a given function is determined either conceptually or from the software report file, the delay path of the function can easily be determined from the timing model. The Lattice design tools report the timing delays based on the same timing model for a particular design. Note that the internal timing parameters are given for reference only, and are not tested. The external timing parameters are tested and guaranteed for every device. For more information on the timing model and usage, refer to TN1004, [ispMACH 4000 Timing Model Design and Usage Guidelines](#).

Figure 11. ispMACH 4000 Timing Model

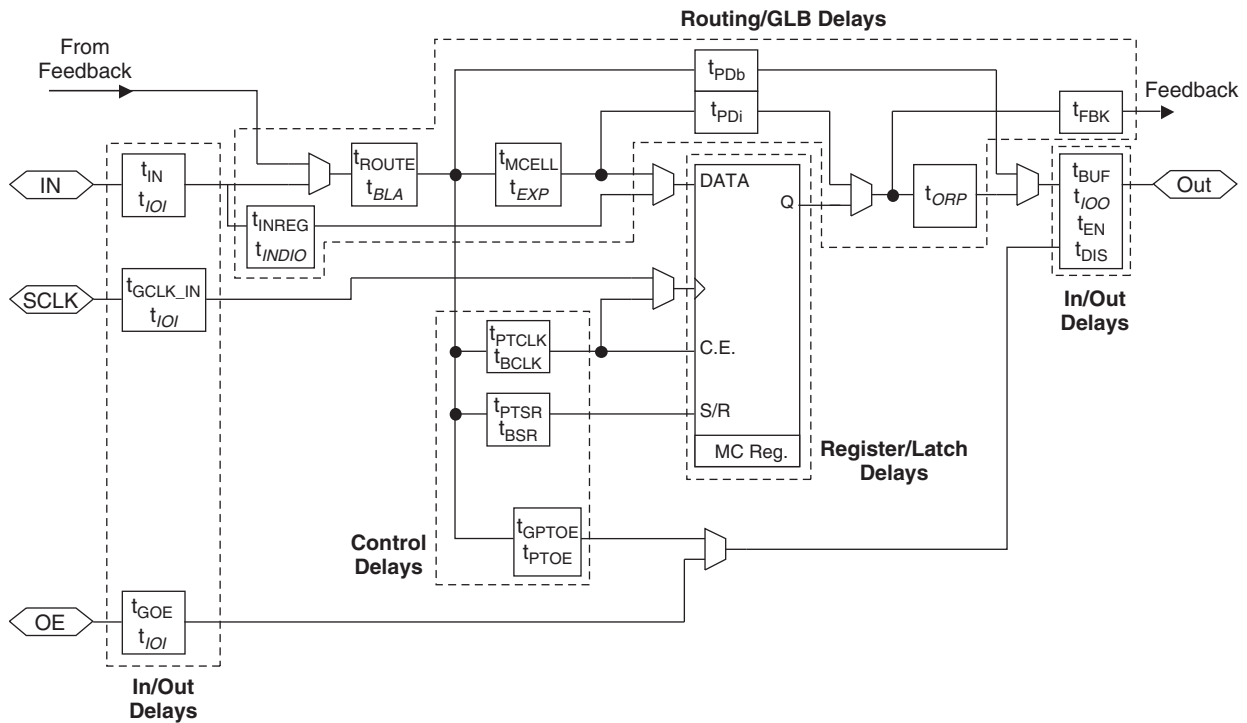

Note: Italicized items are optional delay adders.

ispMACH 4000V/B/C Internal Timing Parameters

Over Recommended Operating Conditions

Parameter	Description	-5		-75		-10		Units
		Min.	Max.	Min.	Max.	Min.	Max.	
In/Out Delays								
t _{IN}	Input Buffer Delay	—	0.95	—	1.50	—	2.00	ns
t _{GOE}	Global OE Pin Delay	—	4.04	—	6.04	—	7.04	ns
t _{GCLK_IN}	Global Clock Input Buffer Delay	—	1.83	—	2.28	—	3.28	ns
t _{BUF}	Delay through Output Buffer	—	1.00	—	1.50	—	1.50	ns
t _{EN}	Output Enable Time	—	0.96	—	0.96	—	0.96	ns
t _{DIS}	Output Disable Time	—	0.96	—	0.96	—	0.96	ns
Routing/GLB Delays								
t _{ROUTE}	Delay through GRP	—	1.51	—	2.26	—	3.26	ns
t _{MCELL}	Macrocell Delay	—	1.05	—	1.45	—	1.95	ns
t _{INREG}	Input Buffer to Macrocell Register Delay	—	0.56	—	0.96	—	1.46	ns
t _{FBK}	Internal Feedback Delay	—	0.00	—	0.00	—	0.00	ns
t _{PDb}	5-PT Bypass Propagation Delay	—	1.54	—	2.24	—	3.24	ns
t _{PDi}	Macrocell Propagation Delay	—	0.94	—	1.24	—	1.74	ns
Register/Latch Delays								
t _S	D-Register Setup Time (Global Clock)	1.32	—	1.57	—	1.57	—	ns
t _{S_PT}	D-Register Setup Time (Product Term Clock)	1.32	—	1.32	—	1.32	—	ns
t _{ST}	T-Register Setup Time (Global Clock)	1.52	—	1.77	—	1.77	—	ns
t _{ST_PT}	T-Register Setup Time (Product Term Clock)	1.32	—	1.32	—	1.32	—	ns
t _H	D-Register Hold Time	1.68	—	2.93	—	3.93	—	ns
t _{HT}	T-Register Hold Time	1.68	—	2.93	—	3.93	—	ns
t _{SIR}	D-Input Register Setup Time (Global Clock)	1.52	—	1.57	—	1.57	—	ns
t _{SIR_PT}	D-Input Register Setup Time (Product Term Clock)	1.45	—	1.45	—	1.45	—	ns
t _{HIR}	D-Input Register Hold Time (Global Clock)	0.68	—	1.18	—	1.18	—	ns
t _{HIR_PT}	D-Input Register Hold Time (Product Term Clock)	0.68	—	1.18	—	1.18	—	ns
t _{COi}	Register Clock to Output/Feedback MUX Time	—	0.52	—	0.67	—	1.17	ns
t _{CES}	Clock Enable Setup Time	2.25	—	2.25	—	2.25	—	ns
t _{CEH}	Clock Enable Hold Time	1.88	—	1.88	—	1.88	—	ns
t _{SL}	Latch Setup Time (Global Clock)	1.32	—	1.57	—	1.57	—	ns
t _{SL_PT}	Latch Setup Time (Product Term Clock)	1.32	—	1.32	—	1.32	—	ns
t _{HL}	Latch Hold Time	1.17	—	1.17	—	1.17	—	ns
t _{GOi}	Latch Gate to Output/Feedback MUX Time	—	0.33	—	0.33	—	0.33	ns
t _{PDLi}	Propagation Delay through Transparent Latch to Output/Feedback MUX	—	0.25	—	0.25	—	0.25	ns
t _{SRI}	Asynchronous Reset or Set to Output/Feedback MUX Delay	0.28	—	0.28	—	0.28	—	ns
t _{SRR}	Asynchronous Reset or Set Recovery Time	1.67	—	1.67	—	1.67	—	ns
Control Delays								
t _{BCLK}	GLB PT Clock Delay	—	1.12	—	1.12	—	0.62	ns
t _{PTCLK}	Macrocell PT Clock Delay	—	0.87	—	0.87	—	0.87	ns
t _{BSR}	GLB PT Set/Reset Delay	—	1.83	—	1.83	—	1.83	ns
t _{PTSR}	Macrocell PT Set/Reset Delay	—	2.51	—	3.41	—	3.41	ns

ispMACH 4000V/B/C Internal Timing Parameters (Cont.)

Over Recommended Operating Conditions

Parameter	Description	-5		-75		-10		Units
		Min.	Max.	Min.	Max.	Min.	Max.	
t _{GP} TOE	Global PT OE Delay	—	5.58	—	5.58	—	5.78	ns
t _P TOE	Macrocell PT OE Delay	—	3.58	—	4.28	—	4.28	ns

Timing v.3.2

Note: Internal Timing Parameters are not tested and are for reference only. Refer to the Timing Model in this data sheet for further details.

ispMACH 4000Z Internal Timing Parameters (Cont.)

Over Recommended Operating Conditions

Parameter	Description	-45		-5		-75		Units
		Min.	Max.	Min.	Max.	Min.	Max.	
t _{P_{TOE}}	Macrocell PT OE Delay	—	2.50	—	2.70	—	2.00	ns

Note: Internal Timing Parameters are not tested and are for reference only. Refer to the timing model in this data sheet for further details. Timing v.2.2

Boundary Scan Waveforms and Timing Specifications

Symbol	Parameter	Min.	Max.	Units
t_{BTCP}	TCK [BSCAN test] clock cycle	40	—	ns
t_{BTCH}	TCK [BSCAN test] pulse width high	20	—	ns
t_{BTCL}	TCK [BSCAN test] pulse width low	20	—	ns
t_{BTSU}	TCK [BSCAN test] setup time	8	—	ns
t_{BTH}	TCK [BSCAN test] hold time	10	—	ns
t_{BRF}	TCK [BSCAN test] rise and fall time	50	—	mV/ns
t_{BTCO}	TAP controller falling edge of clock to valid output	—	10	ns
t_{BTOZ}	TAP controller falling edge of clock to data output disable	—	10	ns
t_{BTVO}	TAP controller falling edge of clock to data output enable	—	10	ns
t_{BTCPSU}	BSCAN test Capture register setup time	8	—	ns
t_{BTCPH}	BSCAN test Capture register hold time	10	—	ns
t_{BTUCO}	BSCAN test Update reg, falling edge of clock to valid output	—	25	ns
t_{BTUOZ}	BSCAN test Update reg, falling edge of clock to output disable	—	25	ns
t_{BTUOV}	BSCAN test Update reg, falling edge of clock to output enable	—	25	ns

ispMACH 4000V/B/C/Z Power Supply and NC Connections¹

Signal	44-pin TQFP ²	48-pin TQFP ²	56-ball csBGA ³	100-pin TQFP ²	128-pin TQFP ²
VCC	11, 33	12, 36	K2, A9	25, 40, 75, 90	32, 51, 96, 115
VCCO0 VCCO (Bank 0)	6	6	F3	13, 33, 95	3, 17, 30, 41, 122
VCCO1 VCCO (Bank 1)	28	30	E8	45, 63, 83	58, 67, 81, 94, 105
GND	12, 34	13, 37	H3, C8	1, 26, 51, 76	1, 33, 65, 97
GND (Bank 0)	5	5	D3	7, 18, 32, 96	10, 24, 40, 113, 123
GND (Bank 1)	27	29	G8	46, 57, 68, 82	49, 59, 74, 88, 104
NC	—	—	4032Z: A8, B10, E1, E3, F8, F10, J1, K3	—	—

1. All grounds must be electrically connected at the board level. However, for the purposes of I/O current loading, grounds are associated with the bank shown.
2. Pin orientation follows the conventional order from pin 1 marking of the top side view and counter-clockwise.
3. Pin orientation A1 starts from the upper left corner of the top side view with alphabetical order ascending vertically and numerical order ascending horizontally.

**ispMACH 4064V/B/C/Z, 4128V/B/C/Z, 4256V/B/C/Z Logic Signal Connections:
100-Pin TQFP (Cont.)**

Pin Number	Bank Number	ispMACH 4064V/B/C/Z		ispMACH 4128V/B/C/Z		ispMACH 4256V/B/C/Z	
		GLB/MC/Pad	ORP	GLB/MC/Pad	ORP	GLB/MC/Pad	ORP
83	1	VCCO (Bank 1)	-	VCCO (Bank 1)	-	VCCO (Bank 1)	-
84	1	D3	D ³	H6	H ³	P12	P ³
85	1	D2	D ²	H4	H ²	P10	P ²
86	1	D1	D ¹	H2	H ¹	P6	P ¹
87	1	D0/GOE1	D ⁰	H0/GOE1	H ⁰	P2/OE1	P ⁰
88	1	CLK3/I	-	CLK3/I	-	CLK3/I	-
89	0	CLK0/I	-	CLK0/I	-	CLK0/I	-
90	-	VCC	-	VCC	-	VCC	-
91	0	A0/GOE0	A ⁰	A0/GOE0	A ⁰	A2/GOE0	A ⁰
92	0	A1	A ¹	A2	A ¹	A6	A ¹
93	0	A2	A ²	A4	A ²	A10	A ²
94	0	A3	A ³	A6	A ³	A12	A ³
95	0	VCCO (Bank 0)	-	VCCO (Bank 0)	-	VCCO (Bank 0)	-
96	0	GND (Bank 0)	-	GND (Bank 0)	-	GND (Bank 0)	-
97	0	A4	A ⁴	A8	A ⁴	B2	B ⁰
98	0	A5	A ⁵	A10	A ⁵	B6	B ¹
99	0	A6	A ⁶	A12	A ⁶	B10	B ²
100	0	A7	A ⁷	A14	A ⁷	B12	B ³

*This pin is input only.

ispMACH 4128V/B/C Logic Signal Connections: 128-Pin TQFP

Pin Number	Bank Number	ispMACH 4128V/B/C	
		GLB/MC/Pad	ORP
1	0	GND	-
2	0	TDI	-
3	0	VCCO (Bank 0)	-
4	0	B0	B ⁰
5	0	B1	B ¹
6	0	B2	B ²
7	0	B4	B ³
8	0	B5	B ⁴
9	0	B6	B ⁵
10	0	GND (Bank 0)	-
11	0	B8	B ⁶
12	0	B9	B ⁷
13	0	B10	B ⁸
14	0	B12	B ⁹
15	0	B13	B ¹⁰
16	0	B14	B ¹¹
17	0	VCCO (Bank 0)	-
18	0	C14	C ¹¹

ispMACH 4128V/B/C Logic Signal Connections: 128-Pin TQFP (Cont.)

Pin Number	Bank Number	ispMACH 4128V/B/C	
		GLB/MC/Pad	ORP
19	0	C13	C^10
20	0	C12	C^9
21	0	C10	C^8
22	0	C9	C^7
23	0	C8	C^6
24	0	GND (Bank 0)	-
25	0	C6	C^5
26	0	C5	C^4
27	0	C4	C^3
28	0	C2	C^2
29	0	C0	C^0
30	0	VCCO (Bank 0)	-
31	0	TCK	-
32	0	VCC	-
33	0	GND	-
34	0	D14	D^11
35	0	D13	D^10
36	0	D12	D^9
37	0	D10	D^8
38	0	D9	D^7
39	0	D8	D^6
40	0	GND (Bank 0)	-
41	0	VCCO (Bank 0)	-
42	0	D6	D^5
43	0	D5	D^4
44	0	D4	D^3
45	0	D2	D^2
46	0	D1	D^1
47	0	D0	D^0
48	0	CLK1/I	-
49	1	GND (Bank 1)	-
50	1	CLK2/I	-
51	1	VCC	-
52	1	E0	E^0
53	1	E1	E^1
54	1	E2	E^2
55	1	E4	E^3
56	1	E5	E^4
57	1	E6	E^5
58	1	VCCO (Bank 1)	-
59	1	GND (Bank 1)	-
60	1	E8	E^6
61	1	E9	E^7

ispMACH 4128V and 4256V Logic Signal Connections: 144-Pin TQFP (Cont.)

Pin Number	Bank Number	ispMACH 4128V		ispMACH 4256V	
		GLB/MC/Pad	ORP	GLB/MC/Pad	ORP
43	0	D9	D [^] 7	G4	G [^] 2
44	0	D8	D [^] 6	G2	G [^] 1
45	0	NC ²	-	I ²	-
46	0	GND (Bank 0)	-	GND (Bank 0)	-
47	0	VCCO (Bank 0)	-	VCCO (Bank 0)	-
48	0	D6	D [^] 5	H12	H [^] 6
49	0	D5	D [^] 4	H10	H [^] 5
50	0	D4	D [^] 3	H8	H [^] 4
51	0	D2	D [^] 2	H6	H [^] 3
52	0	D1	D [^] 1	H4	H [^] 2
53	0	D0	D [^] 0	H2	H [^] 1
54	0	CLK1/I	-	CLK1/I	-
55	1	GND (Bank 1)	-	GND (Bank 1)	-
56	1	CLK2/I	-	CLK2/I	-
57	-	VCC	-	VCC	-
58	1	E0	E [^] 0	I2	I [^] 1
59	1	E1	E [^] 1	I4	I [^] 2
60	1	E2	E [^] 2	I6	I [^] 3
61	1	E4	E [^] 3	I8	I [^] 4
62	1	E5	E [^] 4	I10	I [^] 5
63	1	E6	E [^] 5	I12	I [^] 6
64	1	VCCO (Bank 1)	-	VCCO (Bank 1)	-
65	1	GND (Bank 1)	-	GND (Bank 1)	-
66	1	E8	E [^] 6	J2	J [^] 1
67	1	E9	E [^] 7	J4	J [^] 2
68	1	E10	E [^] 8	J6	J [^] 3
69	1	E12	E [^] 9	J8	J [^] 4
70	1	E13	E [^] 10	J10	J [^] 5
71	1	E14	E [^] 11	J12	J [^] 6
72	1	NC ²	-	I ²	-
73	-	GND	-	GND	-
74	-	TMS	-	TMS	-
75	1	VCCO (Bank 1)	-	VCCO (Bank 1)	-
76	1	F0	F [^] 0	K12	K [^] 6
77	1	F1	F [^] 1	K10	K [^] 5
78	1	F2	F [^] 2	K8	K [^] 4
79	1	F4	F [^] 3	K6	K [^] 3
80	1	F5	F [^] 4	K4	K [^] 2
81	1	F6	F [^] 5	K2	K [^] 1
82	1	GND (Bank 1)	-	GND (Bank 1)	-
83	1	F8	F [^] 6	L14	L [^] 7
84	1	F9	F [^] 7	L12	L [^] 6
85	1	F10	F [^] 8	L10	L [^] 5

**ispMACH 4256V/B/C/Z, 4384V/B/C, 4512V/B/C, Logic Signal Connections:
176-Pin TQFP (Cont.)**

Pin Number	Bank Number	ispMACH 4256V/B/C/Z		ispMACH 4384V/B/C		ispMACH 4512V/B/C	
		GLB/MC/Pad	ORP	GLB/MC/Pad	ORP	GLB/MC/Pad	ORP
19	0	D4	D ²	E4	E ²	G4	G ²
20	0	D2	D ¹	E2	E ¹	G2	G ¹
21	0	D0	D ⁰	E0	E ⁰	G0	G ⁰
22	0	VCCO (Bank 0)	-	VCCO (Bank 0)	-	VCCO (Bank 0)	-
23	0	E0	E ⁰	H0	H ⁰	J0	J ⁰
24	0	E2	E ¹	H2	H ¹	J2	J ¹
25	0	E4	E ²	H4	H ²	J4	J ²
26	0	E6	E ³	H6	H ³	J6	J ³
27	0	E8	E ⁴	H8	H ⁴	J8	J ⁴
28	0	E10	E ⁵	H10	H ⁵	J10	J ⁵
29	0	E12	E ⁶	H12	H ⁶	J12	J ⁶
30	0	E14	E ⁷	H14	H ⁷	J14	J ⁷
31	0	GND (Bank 0)	-	GND (Bank 0)	-	GND (Bank 0)	-
32	0	F0	F ⁰	J0	J ⁰	N0	N ⁰
33	0	F2	F ¹	J2	J ¹	N2	N ¹
34	0	F4	F ²	J4	J ²	N4	N ²
35	0	F6	F ³	J6	J ³	N6	N ³
36	0	F8	F ⁴	J8	J ⁴	N8	N ⁴
37	0	F10	F ⁵	J10	J ⁵	N10	N ⁵
38	0	F12	F ⁶	J12	J ⁶	N12	N ⁶
39	0	F14	F ⁷	J14	J ⁷	N14	N ⁷
40	0	VCCO (Bank 0)	-	VCCO (Bank 0)	-	VCCO (Bank 0)	-
41	-	TCK	-	TCK	-	TCK	-
42	-	VCC	-	VCC	-	VCC	-
43	-	NC	-	NC	-	NC	-
44	-	NC	-	NC	-	NC	-
45	-	NC	-	NC	-	NC	-
46	-	GND	-	GND (Bank 0)	-	GND	-
47	0	G14	G ⁷	K14	K ⁷	O14	O ⁷
48	0	G12	G ⁶	K12	K ⁶	O12	O ⁶
49	0	G10	G ⁵	K10	K ⁵	O10	O ⁵
50	0	G8	G ⁴	K8	K ⁴	O8	O ⁴
51	0	G6	G ³	K6	K ³	O6	O ³
52	0	G4	G ²	K4	K ²	O4	O ²
53	0	G2	G ¹	K2	K ¹	O2	O ¹
54	0	G0	G ⁰	K0	K ⁰	O0	O ⁰
55	0	GND (Bank 0)	-	GND (Bank 0)	-	GND (Bank 0)	-
56	0	VCCO (Bank 0)	-	VCCO (Bank 0)	-	VCCO (Bank 0)	-
57	0	H14	H ⁷	L14	L ⁷	P14	P ⁷
58	0	H12	H ⁶	L12	L ⁶	P12	P ⁶
59	0	H10	H ⁵	L10	L ⁵	P10	P ⁵

**ispMACH 4256V/B/C, 4384V/B/C, 4512V/B/C Logic Signal Connections:
256-Ball ftBGA/fpBGA**

Ball Number	I/O Bank	ispMACH 4256V/B/C 128-I/O		ispMACH 4256V/B/C 160-I/O		ispMACH 4384V/B/C		ispMACH 4512V/B/C	
		GLB/MC/Pad	ORP	GLB/MC/Pad	ORP	GLB/MC/Pad	ORP	GLB/MC/Pad	ORP
-	-	-	-	-	-	VCC	-	VCC	-
-	-	GND	-	GND	-	GND	-	GND	-
C3	-	TDI	-	TDI	-	TDI	-	TDI	-
-	0	VCCO (Bank 0)	-	VCCO (Bank 0)	-	VCCO (Bank 0)	-	VCCO (Bank 0)	-
B1	0	C14	C^7	C14	C^9	C14	C^7	C14	C^7
F5	0	C12	C^6	C12	C^8	C12	C^6	C12	C^6
D3	0	C10	C^5	C10	C^7	C10	C^5	C10	C^5
C1	0	C8	C^4	C9	C^6	C8	C^4	C8	C^4
C2	0	C6	C^3	C8	C^5	C6	C^3	C6	C^3
E3	0	C4	C^2	C6	C^4	C4	C^2	C4	C^2
D2	0	C2	C^1	C4	C^3	C2	C^1	C2	C^1
F6	0	C0	C^0	C2	C^2	C0	C^0	C0	C^0
D1	0	NC	-	C1	C^1	F6	F^3	H0	H^0
E2	0	NC	-	C0	C^0	F4	F^2	H4	H^1
E4	0	NC	-	NC	-	D6	D^3	F4	F^2
G5	0	NC	-	NC	-	D4	D^2	F6	F^3
E1	0	NC	-	NC	-	NC	-	F8	F^4
-	0	-	-	VCCO (Bank 0)	-	VCCO (Bank 0)	-	VCCO (Bank 0)	-
-	0	GND (Bank 0)	-	GND (Bank 0)	-	GND (Bank 0)	-	GND (Bank 0)	-
F2	0	NC	-	NC	-	NC	-	F10	F^5
F1	0	NC	-	NC	-	D2	D^1	F12	F^6
G1	0	NC	-	NC	-	D0	D^0	F14	F^7
G6	0	NC	-	D14	D^9	F2	F^1	H8	H^2
G4	0	NC	-	D12	D^8	F0	F^0	H12	H^3
H6	0	D14	D^7	D10	D^7	E14	E^7	G14	G^7
G3	0	D12	D^6	D9	D^6	E12	E^6	G12	G^6
H5	0	D10	D^5	D8	D^5	E10	E^5	G10	G^5
G2	0	D8	D^4	D6	D^4	E8	E^4	G8	G^4
H1	0	D6	D^3	D4	D^3	E6	E^3	G6	G^3
H2	0	D4	D^2	D2	D^2	E4	E^2	G4	G^2
H3	0	D2	D^1	D1	D^1	E2	E^1	G2	G^1
H4	0	D0	D^0	D0	D^0	E0	E^0	G0	G^0
-	0	VCCO (Bank 0)	-	VCCO (Bank 0)	-	VCCO (Bank 0)	-	VCCO (Bank 0)	-
-	0	-	-	GND (Bank 0)	-	GND (Bank 0)	-	GND (Bank 0)	-
J4	0	E0	E^0	E0	E^0	H0	H^0	J0	J^0
J3	0	E2	E^1	E1	E^1	H2	H^1	J2	J^1
J2	0	E4	E^2	E2	E^2	H4	H^2	J4	J^2
J1	0	E6	E^3	E4	E^3	H6	H^3	J6	J^3
K1	0	E8	E^4	E6	E^4	H8	H^4	J8	J^4
J5	0	E10	E^5	E8	E^5	H10	H^5	J10	J^5
K2	0	E12	E^6	E9	E^6	H12	H^6	J12	J^6

ispMACH 4000B (2.5V) Commercial Devices (Cont.)

Device	Part Number	Macrocells	Voltage	t _{PD}	Package	Pin/Ball Count	I/O	Grade
LC4256B	LC4256B-3FT256AC	256	2.5	3	ftBGA	256	128	C
	LC4256B-5FT256AC	256	2.5	5	ftBGA	256	128	C
	LC4256B-75FT256AC	256	2.5	7.5	ftBGA	256	128	C
	LC4256B-3FT256BC	256	2.5	3	ftBGA	256	160	C
	LC4256B-5FT256BC	256	2.5	5	ftBGA	256	160	C
	LC4256B-75FT256BC	256	2.5	7.5	ftBGA	256	160	C
	LC4256B-3F256AC ¹	256	2.5	3	fpBGA	256	128	C
	LC4256B-5F256AC ¹	256	2.5	5	fpBGA	256	128	C
	LC4256B-75F256AC ¹	256	2.5	7.5	fpBGA	256	128	C
	LC4256B-3F256BC ¹	256	2.5	3	fpBGA	256	160	C
	LC4256B-5F256BC ¹	256	2.5	5	fpBGA	256	160	C
	LC4256B-75F256BC ¹	256	2.5	7.5	fpBGA	256	160	C
	LC4256B-3T176C	256	2.5	3	TQFP	176	128	C
	LC4256B-5T176C	256	2.5	5	TQFP	176	128	C
	LC4256B-75T176C	256	2.5	7.5	TQFP	176	128	C
	LC4256B-3T100C	256	2.5	3	TQFP	100	64	C
	LC4256B-5T100C	256	2.5	5	TQFP	100	64	C
LC4256B-75T100C	256	2.5	7.5	TQFP	100	64	C	
LC4384B	LC4384B-35FT256C	384	2.5	3.5	ftBGA	256	192	C
	LC4384B-5FT256C	384	2.5	5	ftBGA	256	192	C
	LC4384B-75FT256C	384	2.5	7.5	ftBGA	256	192	C
	LC4384B-35F256C ¹	384	2.5	3.5	fpBGA	256	192	C
	LC4384B-5F256C ¹	384	2.5	5	fpBGA	256	192	C
	LC4384B-75F256C ¹	384	2.5	7.5	fpBGA	256	192	C
	LC4384B-35T176C	384	2.5	3.5	TQFP	176	128	C
	LC4384B-5T176C	384	2.5	5	TQFP	176	128	C
	LC4384B-75T176C	384	2.5	7.5	TQFP	176	128	C
LC4512B	LC4512B-35FT256C	512	2.5	3.5	ftBGA	256	208	C
	LC4512B-5FT256C	512	2.5	5	ftBGA	256	208	C
	LC4512B-75FT256C	512	2.5	7.5	ftBGA	256	208	C
	LC4512B-35F256C ¹	512	2.5	3.5	fpBGA	256	208	C
	LC4512B-5F256C ¹	512	2.5	5	fpBGA	256	208	C
	LC4512B-75F256C ¹	512	2.5	7.5	fpBGA	256	208	C
	LC4512B-35T176C	512	2.5	3.5	TQFP	176	128	C
	LC4512B-5T176C	512	2.5	5	TQFP	176	128	C
	LC4512B-75T176C	512	2.5	7.5	TQFP	176	128	C

1. Use ftBGA package. fpBGA package devices have been discontinued via PCN#14A-07.

ispMACH 4000V (3.3V) Industrial Devices (Cont.)

Family	Part Number	Macrocells	Voltage	t _{PD}	Package	Pin/Ball Count	I/O	Grade
LC4256V	LC4256V-5FT256AI	256	3.3	5	ftBGA	256	128	I
	LC4256V-75FT256AI	256	3.3	7.5	ftBGA	256	128	I
	LC4256V-10FT256AI	256	3.3	10	ftBGA	256	128	I
	LC4256V-5FT256BI	256	3.3	5	ftBGA	256	160	I
	LC4256V-75FT256BI	256	3.3	7.5	ftBGA	256	160	I
	LC4256V-10FT256BI	256	3.3	10	ftBGA	256	160	I
	LC4256V-5F256AI ¹	256	3.3	5	fpBGA	256	128	I
	LC4256V-75F256AI ¹	256	3.3	7.5	fpBGA	256	128	I
	LC4256V-10F256AI ¹	256	3.3	10	fpBGA	256	128	I
	LC4256V-5F256BI ¹	256	3.3	5	fpBGA	256	160	I
	LC4256V-75F256BI ¹	256	3.3	7.5	fpBGA	256	160	I
	LC4256V-10F256BI ¹	256	3.3	10	fpBGA	256	160	I
	LC4256V-5T176I	256	3.3	5	TQFP	176	128	I
	LC4256V-75T176I	256	3.3	7.5	TQFP	176	128	I
	LC4256V-10T176I	256	3.3	10	TQFP	176	128	I
	LC4256V-5T144I	256	3.3	5	TQFP	144	96	I
	LC4256V-75T144I	256	3.3	7.5	TQFP	144	96	I
	LC4256V-10T144I	256	3.3	10	TQFP	144	96	I
	LC4256V-5T100I	256	3.3	5	TQFP	100	64	I
	LC4256V-75T100I	256	3.3	7.5	TQFP	100	64	I
LC4256V-10T100I	256	3.3	10	TQFP	100	64	I	
LC4384V	LC4384V-5FT256I	384	3.3	5	ftBGA	256	192	I
	LC4384V-75FT256I	384	3.3	7.5	ftBGA	256	192	I
	LC4384V-10FT256I	384	3.3	10	ftBGA	256	192	I
	LC4384V-5F256I ¹	384	3.3	5	fpBGA	256	192	I
	LC4384V-75F256I ¹	384	3.3	7.5	fpBGA	256	192	I
	LC4384V-10F256I ¹	384	3.3	10	fpBGA	256	192	I
	LC4384V-5T176I	384	3.3	5	TQFP	176	128	I
	LC4384V-75T176I	384	3.3	7.5	TQFP	176	128	I
	LC4384V-10T176I	384	3.3	10	TQFP	176	128	I
LC4512V	LC4512V-5FT256I	512	3.3	5	ftBGA	256	208	I
	LC4512V-75FT256I	512	3.3	7.5	ftBGA	256	208	I
	LC4512V-10FT256I	512	3.3	10	ftBGA	256	208	I
	LC4512V-5F256I ¹	512	3.3	5	fpBGA	256	208	I
	LC4512V-75F256I ¹	512	3.3	7.5	fpBGA	256	208	I
	LC4512V-10F256I ¹	512	3.3	10	fpBGA	256	208	I
	LC4512V-5T176I	512	3.3	5	TQFP	176	128	I
	LC4512V-75T176I	512	3.3	7.5	TQFP	176	128	I
	LC4512V-10T176I	512	3.3	10	TQFP	176	128	I

1. Use ftBGA package. fpBGA package devices have been discontinued via PCN#14A-07.

ispMACH 4000V (3.3V) Extended Temperature Devices

Device	Part Number	Macrocells	Voltage	t _{PD}	Package	Pin/Ball Count	I/O	Grade
LC4032V	LC4032V-75T48E	32	3.3	7.5	TQFP	48	32	E
	LC4032V-75T44E	32	3.3	7.5	TQFP	44	30	E
LC4064V	LC4064V-75T100E	64	3.3	7.5	TQFP	100	64	E
	LC4064V-75T48E	64	3.3	7.5	TQFP	48	32	E
	LC4064V-75T44E	64	3.3	7.5	TQFP	44	30	E
LC4128V	LC4128V-75T144E	128	3.3	7.5	TQFP	144	96	E
	LC4128V-75T128E	128	3.3	7.5	TQFP	128	92	E
	LC4128V-75T100E	128	3.3	7.5	TQFP	100	64	E
LC4256V	LC4256V-75T176E	256	3.3	7.5	TQFP	176	128	E
	LC4256V-75T144E	256	3.3	7.5	TQFP	144	96	E
	LC4256V-75T100E	256	3.3	7.5	TQFP	100	64	E

ispMACH 4000Z (Zero Power, 1.8V) Lead-Free Industrial Devices (Cont.)

Device	Part Number	Macrocells	Voltage	t _{PD}	Package	Pin/Ball Count	I/O	Grade
LC4064ZC	LC4064ZC-5MN132I	64	1.8	5	Lead-free csBGA	132	64	I
	LC4064ZC-75MN132I	64	1.8	7.5	Lead-free csBGA	132	64	I
	LC4064ZC-5TN100I	64	1.8	5	Lead-free TQFP	100	64	I
	LC4064ZC-75TN100I	64	1.8	7.5	Lead-free TQFP	100	64	I
	LC4064ZC-5MN56I	64	1.8	5	Lead-free csBGA	56	32	I
	LC4064ZC-75MN56I	64	1.8	7.5	Lead-free csBGA	56	32	I
	LC4064ZC-5TN48I	64	1.8	5	Lead-free TQFP	48	32	I
	LC4064ZC-75TN48I	64	1.8	7.5	Lead-free TQFP	48	32	I
LC4128ZC	LC4128ZC-75MN132I	128	1.8	7.5	Lead-free csBGA	132	96	I
	LC4128ZC-75TN100I	128	1.8	7.5	Lead-free TQFP	100	64	I
LC4256ZC	LC4256ZC-75TN176I	256	1.8	7.5	Lead-free TQFP	176	128	I
	LC4256ZC-75MN132I	256	1.8	7.5	Lead-free csBGA	132	96	I
	LC4256ZC-75TN100I	256	1.8	7.5	Lead-free TQFP	100	64	I

ispMACH 4000Z (Zero Power, 1.8V) Lead-Free Extended Temperature Devices

Device	Part Number	Macrocells	Voltage	t _{PD}	Package	Pin/Ball Count	I/O	Grade
LC4032ZC	LC4032ZC-75TN48E	32	1.8	7.5	Lead-free TQFP	48	32	E
LC4064ZC	LC4064ZC-75TN100E	64	1.8	7.5	Lead-free TQFP	100	64	E
	LC4064ZC-75TN48E	64	1.8	7.5	Lead-free TQFP	48	32	E
LC4128ZC	LC4128ZC-75TN100E	128	1.8	7.5	Lead-free TQFP	100	64	E
LC4256ZC	LC4256ZC-75TN176E	256	1.8	7.5	Lead-free TQFP	176	128	E
	LC4256ZC-75TN100E	256	1.8	7.5	Lead-free TQFP	100	64	E

ispMACH 4000C (1.8V) Lead-Free Commercial Devices

Device	Part Number	Macrocells	Voltage	t _{PD}	Package	Pin/Ball Count	I/O	Grade
LC4032C	LC4032C-25TN48C	32	1.8	2.5	Lead-free TQFP	48	32	C
	LC4032C-5TN48C	32	1.8	5	Lead-free TQFP	48	32	C
	LC4032C-75TN48C	32	1.8	7.5	Lead-free TQFP	48	32	C
	LC4032C-25TN44C	32	1.8	2.5	Lead-free TQFP	44	30	C
	LC4032C-5TN44C	32	1.8	5	Lead-free TQFP	44	30	C
	LC4032C-75TN44C	32	1.8	7.5	Lead-free TQFP	44	30	C