



Welcome to [E·XFL.COM](https://www.e-xfl.com)

Understanding [Embedded - FPGAs \(Field Programmable Gate Array\)](#)

Embedded - FPGAs, or Field Programmable Gate Arrays, are advanced integrated circuits that offer unparalleled flexibility and performance for digital systems. Unlike traditional fixed-function logic devices, FPGAs can be programmed and reprogrammed to execute a wide array of logical operations, enabling customized functionality tailored to specific applications. This reprogrammability allows developers to iterate designs quickly and implement complex functions without the need for custom hardware.

Applications of Embedded - FPGAs

The versatility of Embedded - FPGAs makes them indispensable in numerous fields. In telecommunications,

Details

Product Status	Active
Number of LABs/CLBs	150
Number of Logic Elements/Cells	1200
Total RAM Bits	9421
Number of I/O	73
Number of Gates	-
Voltage - Supply	1.71V ~ 3.465V
Mounting Type	Surface Mount
Operating Temperature	0°C ~ 85°C (TJ)
Package / Case	100-LQFP
Supplier Device Package	100-TQFP (14x14)
Purchase URL	https://www.e-xfl.com/product-detail/lattice-semiconductor/lcmxo1200c-4tn100c

Figure 2-6. Distributed Memory Primitives

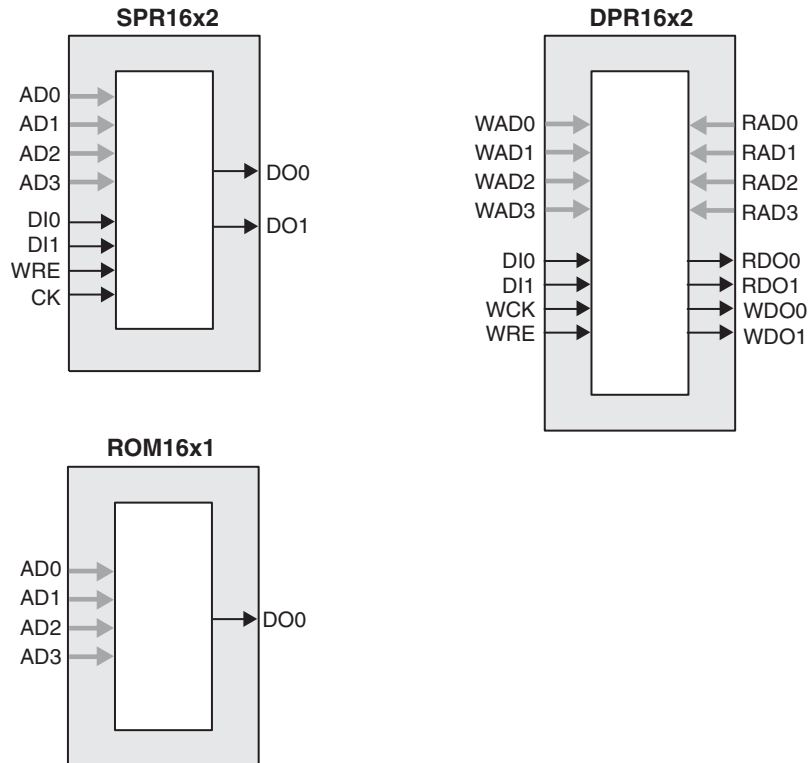

ROM Mode: The ROM mode uses the same principal as the RAM modes, but without the Write port. Pre-loading is accomplished through the programming interface during configuration.

PFU Modes of Operation

Slices can be combined within a PFU to form larger functions. Table 2-4 tabulates these modes and documents the functionality possible at the PFU level.

Table 2-4. PFU Modes of Operation

Logic	Ripple	RAM	ROM
LUT 4x8 or MUX 2x1 x 8	2-bit Add x 4	SPR16x2 x 4 DPR16x2 x 2	ROM16x1 x 8
LUT 5x4 or MUX 4x1 x 4	2-bit Sub x 4	SPR16x4 x 2 DPR16x4 x 1	ROM16x2 x 4
LUT 6x 2 or MUX 8x1 x 2	2-bit Counter x 4	SPR16x8 x 1	ROM16x4 x 2
LUT 7x1 or MUX 16x1 x 1	2-bit Comp x 4		ROM16x8 x 1

Routing

There are many resources provided in the MachXO devices to route signals individually or as buses with related control signals. The routing resources consist of switching circuitry, buffers and metal interconnect (routing) segments.

The inter-PFU connections are made with three different types of routing resources: x1 (spans two PFUs), x2 (spans three PFUs) and x6 (spans seven PFUs). The x1, x2, and x6 connections provide fast and efficient connections in the horizontal and vertical directions.

The EBR memory supports three forms of write behavior for single or dual port operation:

1. **Normal** – data on the output appears only during the read cycle. During a write cycle, the data (at the current address) does not appear on the output. This mode is supported for all data widths.
2. **Write Through** – a copy of the input data appears at the output of the same port. This mode is supported for all data widths.
3. **Read-Before-Write** – when new data is being written, the old contents of the address appears at the output. This mode is supported for x9, x18 and x36 data widths.

FIFO Configuration

The FIFO has a write port with Data-in, CEW, WE and CLKW signals. There is a separate read port with Data-out, RCE, RE and CLKR signals. The FIFO internally generates Almost Full, Full, Almost Empty and Empty Flags. The Full and Almost Full flags are registered with CLKW. The Empty and Almost Empty flags are registered with CLKR. The range of programming values for these flags are in Table 2-7.

Table 2-7. Programmable FIFO Flag Ranges

Flag Name	Programming Range
Full (FF)	1 to (up to 2^N-1)
Almost Full (AF)	1 to Full-1
Almost Empty (AE)	1 to Full-1
Empty (EF)	0

N = Address bit width

The FIFO state machine supports two types of reset signals: RSTA and RSTB. The RSTA signal is a global reset that clears the contents of the FIFO by resetting the read/write pointer and puts the FIFO flags in their initial reset state. The RSTB signal is used to reset the read pointer. The purpose of this reset is to retransmit the data that is in the FIFO. In these applications it is important to keep careful track of when a packet is written into or read from the FIFO.

Memory Core Reset

The memory array in the EBR utilizes latches at the A and B output ports. These latches can be reset asynchronously. RSTA and RSTB are local signals, which reset the output latches associated with Port A and Port B respectively. The Global Reset (GSRN) signal resets both ports. The output data latches and associated resets for both ports are as shown in Figure 2-13.

Figure 2-18. MachXO2280 Banks

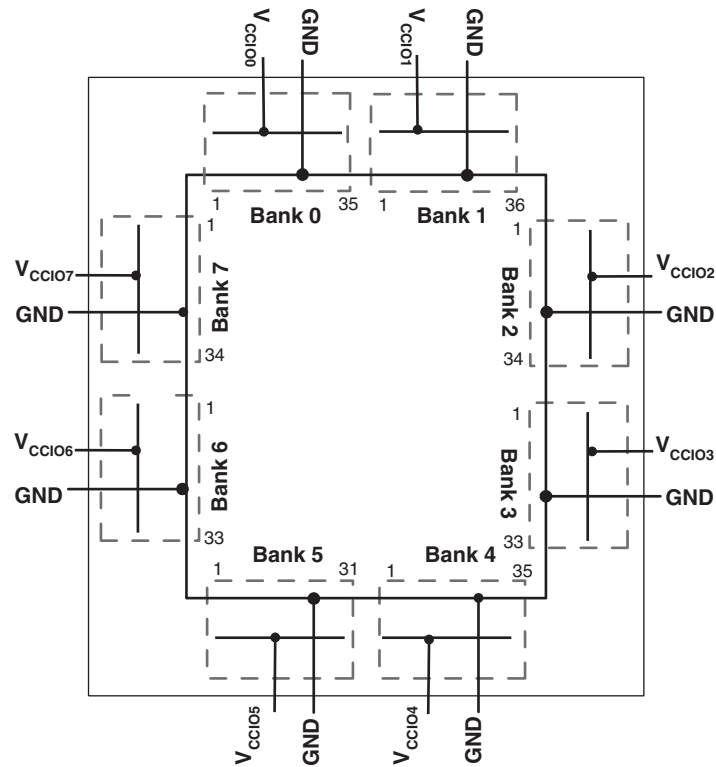
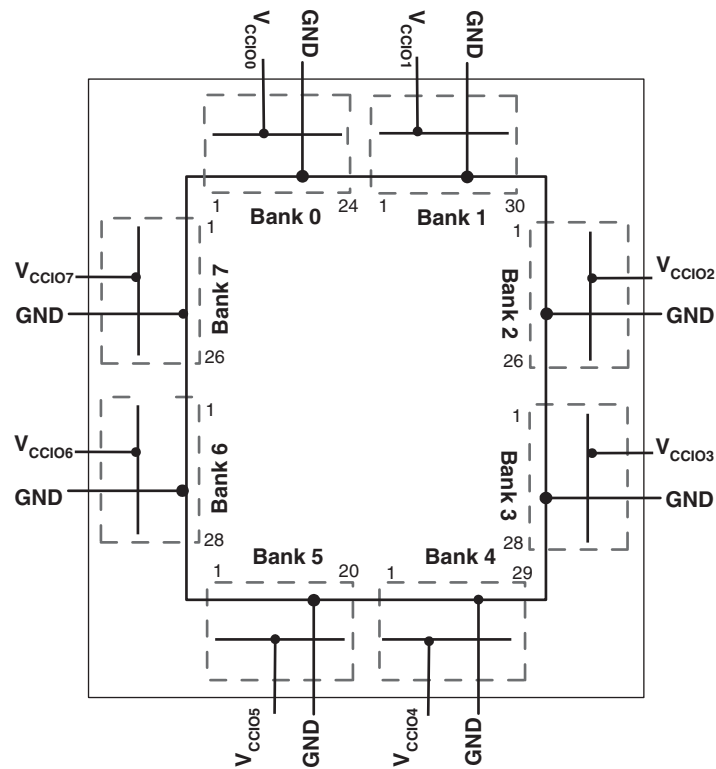

Figure 2-19. MachXO1200 Banks



Device Configuration

All MachXO devices contain a test access port that can be used for device configuration and programming.

The non-volatile memory in the MachXO can be configured in two different modes:

- In IEEE 1532 mode via the IEEE 1149.1 port. In this mode, the device is off-line and I/Os are controlled by BSCAN registers.
- In background mode via the IEEE 1149.1 port. This allows the device to remain operational in user mode while reprogramming takes place.

The SRAM configuration memory can be configured in three different ways:

- At power-up via the on-chip non-volatile memory.
- After a refresh command is issued via the IEEE 1149.1 port.
- In IEEE 1532 mode via the IEEE 1149.1 port.

Figure 2-22 provides a pictorial representation of the different programming modes available in the MachXO devices. On power-up, the SRAM is ready to be configured with IEEE 1149.1 serial TAP port using IEEE 1532 protocols.

Leave Alone I/O

When using IEEE 1532 mode for non-volatile memory programming, SRAM configuration, or issuing a refresh command, users may specify I/Os as high, low, tristated or held at current value. This provides excellent flexibility for implementing systems where reconfiguration or reprogramming occurs on-the-fly.

TransFR (Transparent Field Reconfiguration)

TransFR (TFR) is a unique Lattice technology that allows users to update their logic in the field without interrupting system operation using a single ispVM command. See TN1087, [Minimizing System Interruption During Configuration Using TransFR Technology](#) for details.

Security

The MachXO devices contain security bits that, when set, prevent the readback of the SRAM configuration and non-volatile memory spaces. Once set, the only way to clear the security bits is to erase the memory space.

For more information on device configuration, please see details of additional technical documentation at the end of this data sheet.

Figure 2-22. MachXO Configuration and Programming

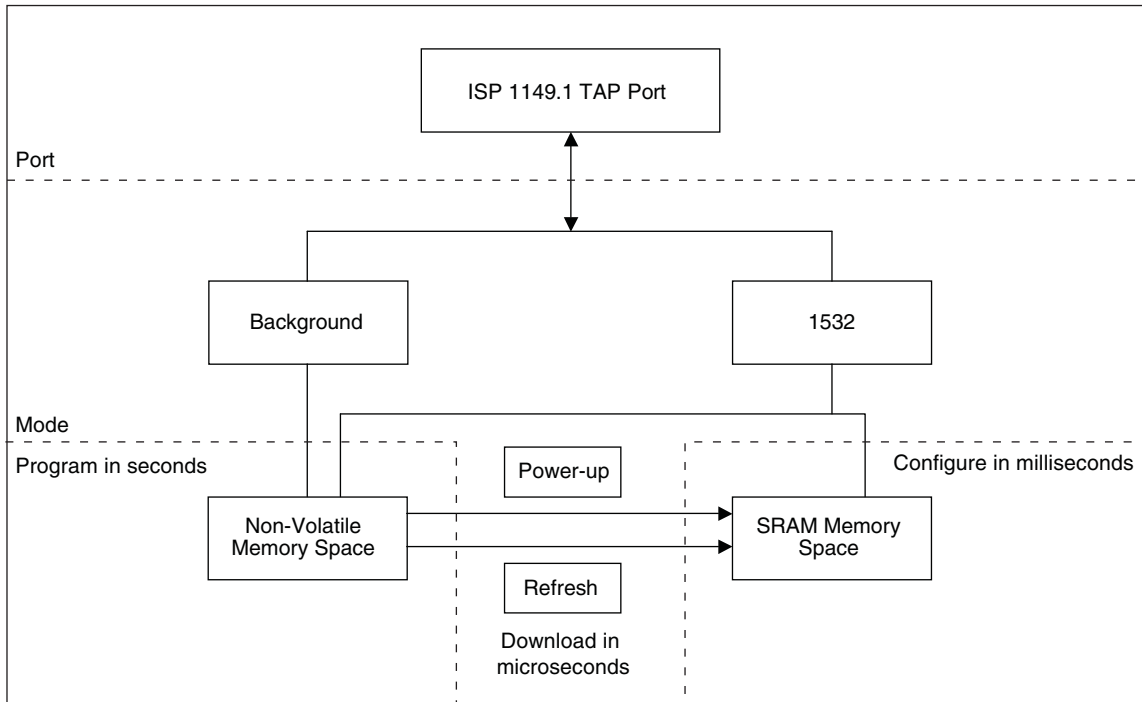

Density Shifting

The MachXO family has been designed to enable density migration in the same package. Furthermore, the architecture ensures a high success rate when performing design migration from lower density parts to higher density parts. In many cases, it is also possible to shift a lower utilization design targeted for a high-density device to a lower density device. However, the exact details of the final resource utilization will impact the likely success in each case.

Initialization Supply Current^{1, 2, 3, 4}

Over Recommended Operating Conditions

Symbol	Parameter	Device	Typ. ⁵	Units
I _{CC}	Core Power Supply	LCMXO256C	13	mA
		LCMXO640C	17	mA
		LCMXO1200C	21	mA
		LCMXO2280C	23	mA
		LCMXO256E	10	mA
		LCMXO640E	14	mA
		LCMXO1200E	18	mA
		LCMXO2280E	20	mA
I _{CCAUX}	Auxiliary Power Supply V _{CCAUX} = 3.3V	LCMXO256E/C	10	mA
		LCMXO640E/C	13	mA
		LCMXO1200E/C	24	mA
		LCMXO2280E/C	25	mA
I _{CCIO}	Bank Power Supply ⁶	All devices	2	mA

- For further information on supply current, please see details of additional technical documentation at the end of this data sheet.
- Assumes all I/O pins are held at V_{CCIO} or GND.
- Frequency = 0MHz.
- Typical user pattern.
- T_J = 25°C, power supplies at nominal voltage.
- Per Bank, V_{CCIO} = 2.5V. Does not include pull-up/pull-down.

Programming and Erase Flash Supply Current^{1, 2, 3, 4}

Symbol	Parameter	Device	Typ. ⁵	Units
I _{CC}	Core Power Supply	LCMXO256C	9	mA
		LCMXO640C	11	mA
		LCMXO1200C	16	mA
		LCMXO2280C	22	mA
		LCMXO256E	6	mA
		LCMXO640E	8	mA
		LCMXO1200E	12	mA
		LCMXO2280E	14	mA
I _{CCAUX}	Auxiliary Power Supply V _{CCAUX} = 3.3V	LCMXO256C/E	8	mA
		LCMXO640C/E	10	mA
		LCMXO1200E	15	mA
		LCMXO2280C/E	16	mA
I _{CCIO}	Bank Power Supply ⁶	All devices	2	mA

- For further information on supply current, please see details of additional technical documentation at the end of this data sheet.
- Assumes all I/O pins are held at V_{CCIO} or GND.
- Typical user pattern.
- JTAG programming is at 25MHz.
- T_J = 25°C, power supplies at nominal voltage.
- Per Bank, V_{CCIO} = 2.5V. Does not include pull-up/pull-down.

Table 3-1. LVDS DC Conditions

Over Recommended Operating Conditions

Parameter	Description	Typical	Units
Z_{OUT}	Output impedance	20	Ω
R_S	Driver series resistor	294	Ω
R_P	Driver parallel resistor	121	Ω
R_T	Receiver termination	100	Ω
V_{OH}	Output high voltage	1.43	V
V_{OL}	Output low voltage	1.07	V
V_{OD}	Output differential voltage	0.35	V
V_{CM}	Output common mode voltage	1.25	V
Z_{BACK}	Back impedance	100	Ω
I_{DC}	DC output current	3.66	mA

BLVDS

The MachXO family supports the BLVDS standard through emulation. The output is emulated using complementary LVCMOS outputs in conjunction with a parallel external resistor across the driver outputs. The input standard is supported by the LVDS differential input buffer on certain devices. BLVDS is intended for use when multi-drop and bi-directional multi-point differential signaling is required. The scheme shown in Figure 3-2 is one possible solution for bi-directional multi-point differential signals.

Figure 3-2. BLVDS Multi-point Output Example

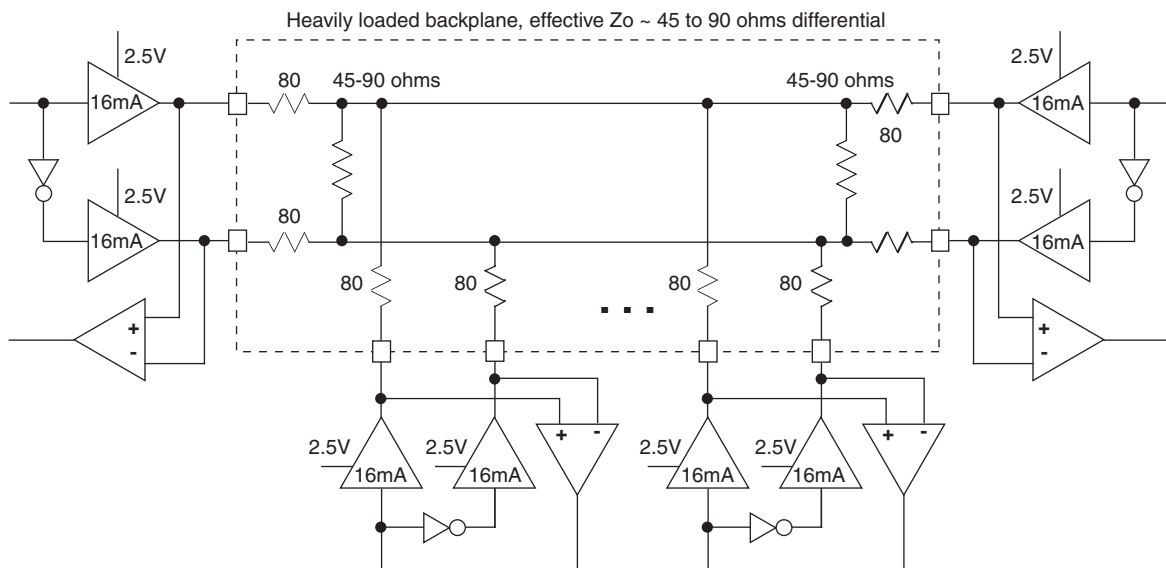

Typical Building Block Function Performance¹

Pin-to-Pin Performance (LVCMOS25 12mA Drive)

Function	-5 Timing	Units
Basic Functions		
16-bit decoder	6.7	ns
4:1 MUX	4.5	ns
16:1 MUX	5.1	ns

Register-to-Register Performance

Function	-5 Timing	Units
Basic Functions		
16:1 MUX	487	MHz
16-bit adder	292	MHz
16-bit counter	388	MHz
64-bit counter	200	MHz
Embedded Memory Functions (1200 and 2280 Devices Only)		
256x36 Single Port RAM	284	MHz
512x18 True-Dual Port RAM	284	MHz
Distributed Memory Functions		
16x2 Single Port RAM	434	MHz
64x2 Single Port RAM	320	MHz
128x4 Single Port RAM	261	MHz
32x2 Pseudo-Dual Port RAM	314	MHz
64x4 Pseudo-Dual Port RAM	271	MHz

1. The above timing numbers are generated using the ispLEVER design tool. Exact performance may vary with device and tool version. The tool uses internal parameters that have been characterized but are not tested on every device.

Rev. A 0.19

Derating Logic Timing

Logic Timing provided in the following sections of the data sheet and the ispLEVER design tools are worst case numbers in the operating range. Actual delays may be much faster. The ispLEVER design tool from Lattice can provide logic timing numbers at a particular temperature and voltage.

MachXO External Switching Characteristics¹

Over Recommended Operating Conditions

Parameter	Description	Device	-5		-4		-3		Units
			Min.	Max.	Min.	Max.	Min.	Max.	
General I/O Pin Parameters (Using Global Clock without PLL)¹									
t _{PD}	Best Case t _{PD} Through 1 LUT	LCMXO256	—	3.5	—	4.2	—	4.9	ns
		LCMXO640	—	3.5	—	4.2	—	4.9	ns
		LCMXO1200	—	3.6	—	4.4	—	5.1	ns
		LCMXO2280	—	3.6	—	4.4	—	5.1	ns
t _{CO}	Best Case Clock to Output - From PFU	LCMXO256	—	4.0	—	4.8	—	5.6	ns
		LCMXO640	—	4.0	—	4.8	—	5.7	ns
		LCMXO1200	—	4.3	—	5.2	—	6.1	ns
		LCMXO2280	—	4.3	—	5.2	—	6.1	ns
t _{SU}	Clock to Data Setup - To PFU	LCMXO256	1.3	—	1.6	—	1.8	—	ns
		LCMXO640	1.1	—	1.3	—	1.5	—	ns
		LCMXO1200	1.1	—	1.3	—	1.6	—	ns
		LCMXO2280	1.1	—	1.3	—	1.5	—	ns
t _H	Clock to Data Hold - To PFU	LCMXO256	-0.3	—	-0.3	—	-0.3	—	ns
		LCMXO640	-0.1	—	-0.1	—	-0.1	—	ns
		LCMXO1200	0.0	—	0.0	—	0.0	—	ns
		LCMXO2280	-0.4	—	-0.4	—	-0.4	—	ns
f _{MAX_IO}	Clock Frequency of I/O and PFU Register	LCMXO256	—	600	—	550	—	500	MHz
		LCMXO640	—	600	—	550	—	500	MHz
		LCMXO1200	—	600	—	550	—	500	MHz
		LCMXO2280	—	600	—	550	—	500	MHz
t _{SKEW_PRI}	Global Clock Skew Across Device	LCMXO256	—	200	—	220	—	240	ps
		LCMXO640	—	200	—	220	—	240	ps
		LCMXO1200	—	220	—	240	—	260	ps
		LCMXO2280	—	220	—	240	—	260	ps

1. General timing numbers based on LVCMOS2.5V, 12 mA.
Rev. A 0.19

MachXO Family Timing Adders^{1, 2, 3}
Over Recommended Operating Conditions

Buffer Type	Description	-5	-4	-3	Units
Input Adjusters					
LVDS25 ⁴	LVDS	0.44	0.53	0.61	ns
BLVDS25 ⁴	BLVDS	0.44	0.53	0.61	ns
LVPECL33 ⁴	LVPECL	0.42	0.50	0.59	ns
LVTTTL33	LVTTTL	0.01	0.01	0.01	ns
LVC MOS33	LVC MOS 3.3	0.01	0.01	0.01	ns
LVC MOS25	LVC MOS 2.5	0.00	0.00	0.00	ns
LVC MOS18	LVC MOS 1.8	0.07	0.08	0.10	ns
LVC MOS15	LVC MOS 1.5	0.14	0.17	0.19	ns
LVC MOS12	LVC MOS 1.2	0.40	0.48	0.56	ns
PCI33 ⁴	PCI	0.01	0.01	0.01	ns
Output Adjusters					
LVDS25E	LVDS 2.5 E	-0.13	-0.15	-0.18	ns
LVDS25 ⁴	LVDS 2.5	-0.21	-0.26	-0.30	ns
BLVDS25	BLVDS 2.5	-0.03	-0.03	-0.04	ns
LVPECL33	LVPECL 3.3	0.04	0.04	0.05	ns
LVTTTL33_4mA	LVTTTL 4mA drive	0.04	0.04	0.05	ns
LVTTTL33_8mA	LVTTTL 8mA drive	0.06	0.07	0.08	ns
LVTTTL33_12mA	LVTTTL 12mA drive	-0.01	-0.01	-0.01	ns
LVTTTL33_16mA	LVTTTL 16mA drive	0.50	0.60	0.70	ns
LVC MOS33_4mA	LVC MOS 3.3 4mA drive	0.04	0.04	0.05	ns
LVC MOS33_8mA	LVC MOS 3.3 8mA drive	0.06	0.07	0.08	ns
LVC MOS33_12mA	LVC MOS 3.3 12mA drive	-0.01	-0.01	-0.01	ns
LVC MOS33_14mA	LVC MOS 3.3 14mA drive	0.50	0.60	0.70	ns
LVC MOS25_4mA	LVC MOS 2.5 4mA drive	0.05	0.06	0.07	ns
LVC MOS25_8mA	LVC MOS 2.5 8mA drive	0.10	0.12	0.13	ns
LVC MOS25_12mA	LVC MOS 2.5 12mA drive	0.00	0.00	0.00	ns
LVC MOS25_14mA	LVC MOS 2.5 14mA drive	0.34	0.40	0.47	ns
LVC MOS18_4mA	LVC MOS 1.8 4mA drive	0.11	0.13	0.15	ns
LVC MOS18_8mA	LVC MOS 1.8 8mA drive	0.05	0.06	0.06	ns
LVC MOS18_12mA	LVC MOS 1.8 12mA drive	-0.06	-0.07	-0.08	ns
LVC MOS18_14mA	LVC MOS 1.8 14mA drive	0.06	0.07	0.09	ns
LVC MOS15_4mA	LVC MOS 1.5 4mA drive	0.15	0.19	0.22	ns
LVC MOS15_8mA	LVC MOS 1.5 8mA drive	0.05	0.06	0.07	ns
LVC MOS12_2mA	LVC MOS 1.2 2mA drive	0.26	0.31	0.36	ns
LVC MOS12_6mA	LVC MOS 1.2 6mA drive	0.05	0.06	0.07	ns
PCI33 ⁴	PCI33	1.85	2.22	2.59	ns

1. Timing adders are characterized but not tested on every device.
 2. LVC MOS timing is measured with the load specified in Switching Test Conditions table.
 3. All other standards tested according to the appropriate specifications.
 4. I/O standard only available in LCMXO1200 and LCMXO2280 devices.
- Rev. A 0.19

Signal Descriptions

Signal Name	I/O	Descriptions
General Purpose		
P[Edge] [Row/Column Number]_[A/B/C/D/E/F]	I/O	<p>[Edge] indicates the edge of the device on which the pad is located. Valid edge designations are L (Left), B (Bottom), R (Right), T (Top).</p> <p>[Row/Column Number] indicates the PFU row or the column of the device on which the PIO Group exists. When Edge is T (Top) or (Bottom), only need to specify Row Number. When Edge is L (Left) or R (Right), only need to specify Column Number.</p> <p>[A/B/C/D/E/F] indicates the PIO within the group to which the pad is connected.</p> <p>Some of these user programmable pins are shared with special function pins. When not used as special function pins, these pins can be programmed as I/Os for user logic.</p> <p>During configuration of the user-programmable I/Os, the user has an option to tri-state the I/Os and enable an internal pull-up resistor. This option also applies to unused pins (or those not bonded to a package pin). The default during configuration is for user-programmable I/Os to be tri-stated with an internal pull-up resistor enabled. When the device is erased, I/Os will be tri-stated with an internal pull-up resistor enabled.</p>
GSRN	I	Global RESET signal (active low). Dedicated pad, when not in use it can be used as an I/O pin.
TSALL	I	TSALL is a dedicated pad for the global output enable signal. When TSALL is high all the outputs are tristated. It is a dual function pin. When not in use, it can be used as an I/O pin.
NC	—	No connect.
GND	—	GND - Ground. Dedicated pins.
V _{CC}	—	VCC - The power supply pins for core logic. Dedicated pins.
V _{CCAUX}	—	VCCAUX - the Auxiliary power supply pin. This pin powers up a variety of internal circuits including all the differential and referenced input buffers. Dedicated pins.
V _{CCIOx}	—	VCCIO - The power supply pins for I/O Bank x. Dedicated pins.
SLEEPN ¹	I	Sleep Mode pin - Active low sleep pin. When this pin is held high, the device operates normally. This pin has a weak internal pull-up, but when unused, an external pull-up to V _{CC} is recommended. When driven low, the device moves into Sleep mode after a specified time.
PLL and Clock Functions (Used as user programmable I/O pins when not used for PLL or clock pins)		
[LOC][0]_PLL[T, C]_IN	—	Reference clock (PLL) input Pads: [LOC] indicates location. Valid designations are ULM (Upper PLL) and LLM (Lower PLL). T = true and C = complement.
[LOC][0]_PLL[T, C]_FB	—	Optional feedback (PLL) input Pads: [LOC] indicates location. Valid designations are ULM (Upper PLL) and LLM (Lower PLL). T = true and C = complement.
PCLK [n]_[1:0]	—	Primary Clock Pads, n per side.
Test and Programming (Dedicated pins)		
TMS	I	Test Mode Select input pin, used to control the 1149.1 state machine.
TCK	I	Test Clock input pin, used to clock the 1149.1 state machine.
TDI	I	Test Data input pin, used to load data into the device using an 1149.1 state machine.
TDO	O	Output pin -Test Data output pin used to shift data out of the device using 1149.1.

1. Applies to MachXO “C” devices only. NC for “E” devices.

LCMXO1200 and LCMXO2280 Logic Signal Connections: 100 TQFP (Cont.)

Pin Number	LCMXO1200				LCMXO2280			
	Ball Function	Bank	Dual Function	Differential	Ball Function	Bank	Dual Function	Differential
42	PB9A	4		T	PB12A	4		T
43	PB9B	4		C	PB12B	4		C
44	VCCIO4	4			VCCIO4	4		
45	PB10A	4		T	PB13A	4		T
46	PB10B	4		C	PB13B	4		C
47***	SLEEPN	-	SLEEPN		SLEEPN	-	SLEEPN	
48	PB11A	4		T	PB16A	4		T
49	PB11B	4		C	PB16B	4		C
50**	GNDIO3 GNDIO4	-			GNDIO3 GNDIO4	-		
51	PR16B	3			PR19B	3		
52	PR15B	3		C*	PR18B	3		C*
53	PR15A	3		T*	PR18A	3		T*
54	PR14B	3		C*	PR17B	3		C*
55	PR14A	3		T*	PR17A	3		T*
56	VCCIO3	3			VCCIO3	3		
57	PR12B	3		C*	PR15B	3		C*
58	PR12A	3		T*	PR15A	3		T*
59	GND	-			GND	-		
60	PR10B	3		C*	PR13B	3		C*
61	PR10A	3		T*	PR13A	3		T*
62	PR9B	3		C*	PR11B	3		C*
63	PR9A	3		T*	PR11A	3		T*
64	PR8B	2		C*	PR10B	2		C*
65	PR8A	2		T*	PR10A	2		T*
66	VCC	-			VCC	-		
67	PR6C	2			PR8C	2		
68	PR6B	2		C*	PR8B	2		C*
69	PR6A	2		T*	PR8A	2		T*
70	VCCIO2	2			VCCIO2	2		
71	PR4D	2			PR5D	2		
72	PR4B	2		C*	PR5B	2		C*
73	PR4A	2		T*	PR5A	2		T*
74	PR2B	2		C	PR3B	2		C*
75	PR2A	2		T	PR3A	2		T*
76**	GNDIO1 GNDIO2	-			GNDIO1 GNDIO2	-		
77	PT11C	1			PT15C	1		
78	PT11B	1		C	PT14B	1		C
79	PT11A	1		T	PT14A	1		T
80	VCCIO1	1			VCCIO1	1		
81	PT9E	1			PT12D	1		C

**LCMXO640, LCMXO1200 and LCMXO2280 Logic Signal Connections:
 256 caBGA / 256 ftBGA (Cont.)**

LCMXO640					LCMXO1200					LCMXO2280				
Ball Number	Ball Function	Bank	Dual Function	Differential	Ball Number	Ball Function	Bank	Dual Function	Differential	Ball Number	Ball Function	Bank	Dual Function	Differential
J13	PR8C	1		T	J13	PR11A	3		T*	J13	PR14A	3		T*
GND	GND	-			GND	GND	-			GND	GND	-		
K14	PR8B	1		C	K14	PR10D	3		C	K14	PR13D	3		C
J14	PR8A	1		T	J14	PR10C	3		T	J14	PR13C	3		T
K15	PR7D	1		C	K15	PR10B	3		C*	K15	PR13B	3		C*
J15	PR7C	1		T	J15	PR10A	3		T*	J15	PR13A	3		T*
-	-	-			GND	GNDIO3	3			GND	GNDIO3	3		
-	-	-			VCCIO3	VCCIO3	3			VCCIO3	VCCIO3	3		
K12	NC				K12	PR9D	3		C	K12	PR11D	3		C
J12	NC				J12	PR9C	3		T	J12	PR11C	3		T
J16	PR7B	1		C	J16	PR9B	3		C*	J16	PR11B	3		C*
H16	PR7A	1		T	H16	PR9A	3		T*	H16	PR11A	3		T*
H15	PR6B	1		C	H15	PR8D	2		C	H15	PR10D	2		C
G15	PR6A	1		T	G15	PR8C	2		T	G15	PR10C	2		T
H14	PR5D	1		C	H14	PR8B	2		C*	H14	PR10B	2		C*
G14	PR5C	1		T	G14	PR8A	2		T*	G14	PR10A	2		T*
GND	GNDIO1	1			GND	GNDIO2	2			GND	GNDIO2	2		
VCCIO1	VCCIO1	1			VCCIO2	VCCIO2	2			VCCIO2	VCCIO2	2		
H13	PR6D	1		C	H13	PR7D	2		C	H13	PR9D	2		C
H12	PR6C	1		T	H12	PR7C	2		T	H12	PR9C	2		T
G13	PR4D	1		C	G13	PR7B	2		C*	G13	PR9B	2		C*
G12	PR4C	1		T	G12	PR7A	2		T*	G12	PR9A	2		T*
G16	PR5B	1		C	G16	PR6D	2		C	G16	PR7D	2		C
F16	PR5A	1		T	F16	PR6C	2		T	F16	PR7C	2		T
F15	PR4B	1		C	F15	PR6B	2		C*	F15	PR7B	2		C*
E15	PR4A	1		T	E15	PR6A	2		T*	E15	PR7A	2		T*
E16	PR3B	1		C	E16	PR5D	2		C	E16	PR6D	2		C
D16	PR3A	1		T	D16	PR5C	2		T	D16	PR6C	2		T
VCCIO1	VCCIO1	1			VCCIO2	VCCIO2	2			VCCIO2	VCCIO2	2		
GND	GNDIO1	1			GND	GNDIO2	2			GND	GNDIO2	2		
D15	PR2D	1		C	D15	PR5B	2		C*	D15	PR6B	2		C*
C15	PR2C	1		T	C15	PR5A	2		T*	C15	PR6A	2		T*
C16	PR2B	1		C	C16	PR4D	2		C	C16	PR5D	2		C
B16	PR2A	1		T	B16	PR4C	2		T	B16	PR5C	2		T
F14	PR3D	1		C	F14	PR4B	2		C*	F14	PR5B	2		C*
E14	PR3C	1		T	E14	PR4A	2		T*	E14	PR5A	2		T*
-	-	-			-	-	-			GND	GND	-		
F12	NC				F12	PR3D	2		C	F12	PR4D	2		C
F13	NC				F13	PR3C	2		T	F13	PR4C	2		T
E12	NC				E12	PR3B	2		C*	E12	PR4B	2		C*
E13	NC				E13	PR3A	2		T*	E13	PR4A	2		T*
D13	NC				D13	PR2B	2		C	D13	PR3B	2		C*
D14	NC				D14	PR2A	2		T	D14	PR3A	2		T*
VCCIO0	VCCIO0	0			VCCIO2	VCCIO2	2			VCCIO2	VCCIO2	2		
GND	GNDIO0	0			GND	GNDIO2	2			GND	GNDIO2	2		
GND	GNDIO0	0			GND	GNDIO1	1			GND	GNDIO1	1		
VCCIO0	VCCIO0	0			VCCIO1	VCCIO1	1			VCCIO1	VCCIO1	1		
B15	NC				B15	PT11D	1		C	B15	PT16D	1		C
A15	NC				A15	PT11C	1		T	A15	PT16C	1		T
C14	NC				C14	PT11B	1		C	C14	PT16B	1		C
B14	NC				B14	PT11A	1		T	B14	PT16A	1		T
C13	PT9F	0		C	C13	PT10F	1		C	C13	PT15D	1		C
B13	PT9E	0		T	B13	PT10E	1		T	B13	PT15C	1		T

LCMXO2280 Logic Signal Connections: 324 ftBGA (Cont.)

LCMXO2280				
Ball Number	Ball Function	Bank	Dual Function	Differential
A10	PT8E	0		T
VCCIO0	VCCIO0	0		
GND	GNDIO0	0		
A9	PT8D	0		C
C9	PT8C	0		T
B9	PT8B	0		C
F9	VCCAUX	-		
A8	PT8A	0		T
B8	PT7D	0		C
C8	PT7C	0		T
VCC	VCC	-		
A7	PT7B	0		C
B7	PT7A	0		T
A6	PT6A	0		T
B6	PT6B	0		C
D8	PT6C	0		T
F8	PT6D	0		C
C7	PT6E	0		T
E8	PT6F	0		C
D7	PT5D	0		C
VCCIO0	VCCIO0	0		
GND	GNDIO0	0		
E7	PT5C	0		T
A5	PT5B	0		C
C6	PT5A	0		T
B5	PT4A	0		T
A4	PT4B	0		C
D6	PT4C	0		T
F7	PT4D	0		C
B4	PT4E	0		T
GND	GND	-		
C5	PT4F	0		C
F6	PT3D	0		C
E5	PT3C	0		T
E6	PT3B	0		C
D5	PT3A	0		T
A3	PT2D	0		C
C4	PT2C	0		T
A2	PT2B	0		C
B2	PT2A	0		T
VCCIO0	VCCIO0	0		
GND	GNDIO0	0		
E14	GND	-		

Thermal Management

Thermal management is recommended as part of any sound FPGA design methodology. To assess the thermal characteristics of a system, Lattice specifies a maximum allowable junction temperature in all device data sheets. Designers must complete a thermal analysis of their specific design to ensure that the device and package do not exceed the junction temperature limits. Refer to the [Thermal Management](#) document to find the device/package specific thermal values.

For Further Information

For further information regarding Thermal Management, refer to the following:

- [Thermal Management](#) document
- TN1090 - [Power Estimation and Management for MachXO Devices](#)
- Power Calculator tool included with the Lattice ispLEVER design tool, or as a standalone download from www.latticesemi.com/software

Part Number Description

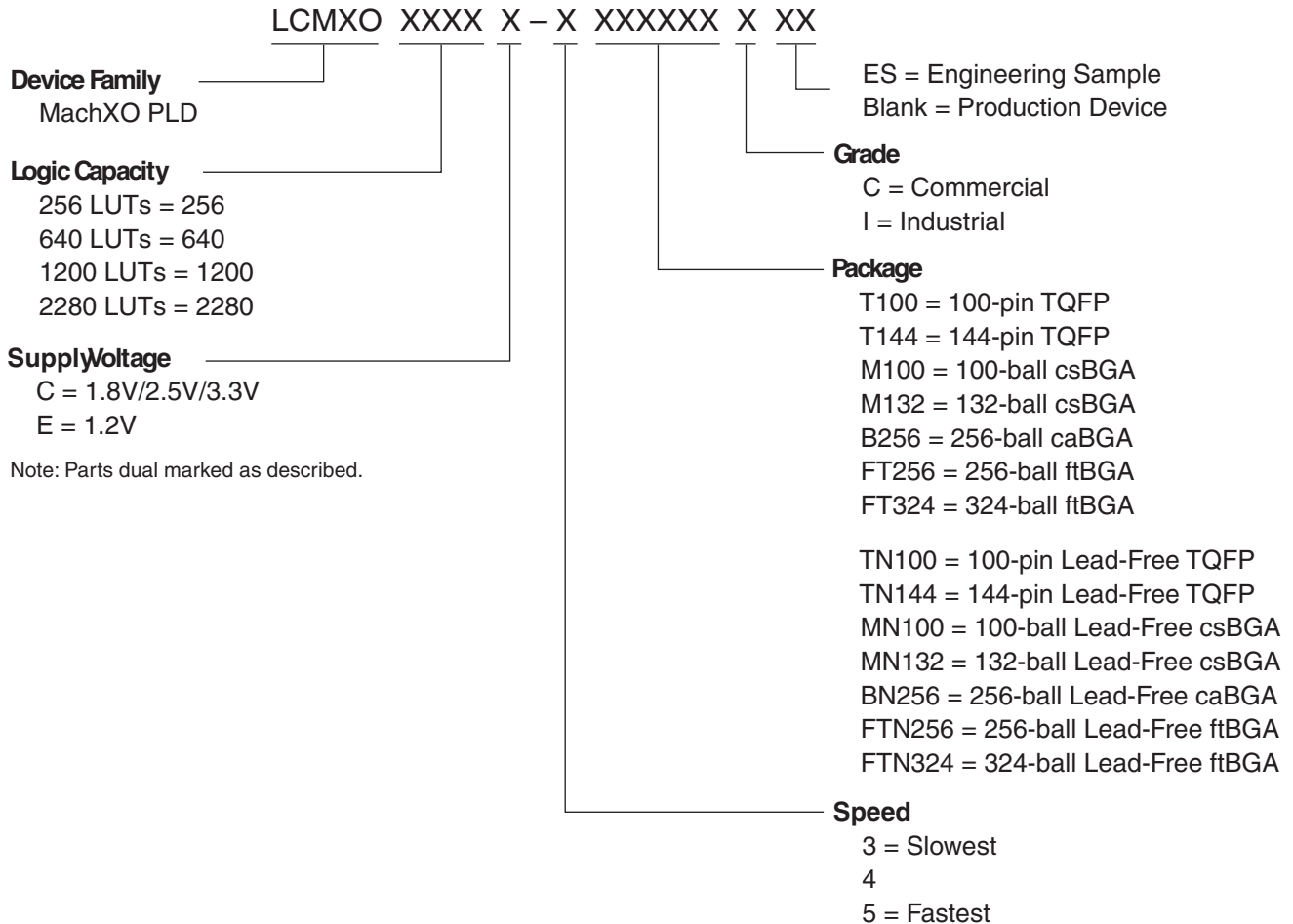

Ordering Information

Note: MachXO devices are dual marked except the slowest commercial speed grade device. For example the commercial speed grade LCMXO640E-4F256C is also marked with industrial grade -3I grade. The slowest commercial speed grade does not have industrial markings. The markings appears as follows:

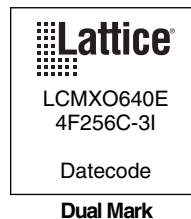

Part Number	LUTs	Supply Voltage	I/Os	Grade	Package	Pins	Temp.
LCMXO2280C-3TN100C	2280	1.8V/2.5V/3.3V	73	-3	Lead-Free TQFP	100	COM
LCMXO2280C-4TN100C	2280	1.8V/2.5V/3.3V	73	-4	Lead-Free TQFP	100	COM
LCMXO2280C-5TN100C	2280	1.8V/2.5V/3.3V	73	-5	Lead-Free TQFP	100	COM
LCMXO2280C-3TN144C	2280	1.8V/2.5V/3.3V	113	-3	Lead-Free TQFP	144	COM
LCMXO2280C-4TN144C	2280	1.8V/2.5V/3.3V	113	-4	Lead-Free TQFP	144	COM
LCMXO2280C-5TN144C	2280	1.8V/2.5V/3.3V	113	-5	Lead-Free TQFP	144	COM
LCMXO2280C-3MN132C	2280	1.8V/2.5V/3.3V	101	-3	Lead-Free csBGA	132	COM
LCMXO2280C-4MN132C	2280	1.8V/2.5V/3.3V	101	-4	Lead-Free csBGA	132	COM
LCMXO2280C-5MN132C	2280	1.8V/2.5V/3.3V	101	-5	Lead-Free csBGA	132	COM
LCMXO2280C-3BN256C	2280	1.8V/2.5V/3.3V	211	-3	Lead-Free caBGA	256	COM
LCMXO2280C-4BN256C	2280	1.8V/2.5V/3.3V	211	-4	Lead-Free caBGA	256	COM
LCMXO2280C-5BN256C	2280	1.8V/2.5V/3.3V	211	-5	Lead-Free caBGA	256	COM
LCMXO2280C-3FTN256C	2280	1.8V/2.5V/3.3V	211	-3	Lead-Free ftBGA	256	COM
LCMXO2280C-4FTN256C	2280	1.8V/2.5V/3.3V	211	-4	Lead-Free ftBGA	256	COM
LCMXO2280C-5FTN256C	2280	1.8V/2.5V/3.3V	211	-5	Lead-Free ftBGA	256	COM
LCMXO2280C-3FTN324C	2280	1.8V/2.5V/3.3V	271	-3	Lead-Free ftBGA	324	COM
LCMXO2280C-4FTN324C	2280	1.8V/2.5V/3.3V	271	-4	Lead-Free ftBGA	324	COM
LCMXO2280C-5FTN324C	2280	1.8V/2.5V/3.3V	271	-5	Lead-Free ftBGA	324	COM

Part Number	LUTs	Supply Voltage	I/Os	Grade	Package	Pins	Temp.
LCMXO256E-3TN100C	256	1.2V	78	-3	Lead-Free TQFP	100	COM
LCMXO256E-4TN100C	256	1.2V	78	-4	Lead-Free TQFP	100	COM
LCMXO256E-5TN100C	256	1.2V	78	-5	Lead-Free TQFP	100	COM
LCMXO256E-3MN100C	256	1.2V	78	-3	Lead-Free csBGA	100	COM
LCMXO256E-4MN100C	256	1.2V	78	-4	Lead-Free csBGA	100	COM
LCMXO256E-5MN100C	256	1.2V	78	-5	Lead-Free csBGA	100	COM

Part Number	LUTs	Supply Voltage	I/Os	Grade	Package	Pins	Temp.
LCMXO640E-3TN100C	640	1.2V	74	-3	Lead-Free TQFP	100	COM
LCMXO640E-4TN100C	640	1.2V	74	-4	Lead-Free TQFP	100	COM
LCMXO640E-5TN100C	640	1.2V	74	-5	Lead-Free TQFP	100	COM
LCMXO640E-3MN100C	640	1.2V	74	-3	Lead-Free csBGA	100	COM
LCMXO640E-4MN100C	640	1.2V	74	-4	Lead-Free csBGA	100	COM
LCMXO640E-5MN100C	640	1.2V	74	-5	Lead-Free csBGA	100	COM
LCMXO640E-3TN144C	640	1.2V	113	-3	Lead-Free TQFP	144	COM
LCMXO640E-4TN144C	640	1.2V	113	-4	Lead-Free TQFP	144	COM
LCMXO640E-5TN144C	640	1.2V	113	-5	Lead-Free TQFP	144	COM
LCMXO640E-3MN132C	640	1.2V	101	-3	Lead-Free csBGA	132	COM
LCMXO640E-4MN132C	640	1.2V	101	-4	Lead-Free csBGA	132	COM
LCMXO640E-5MN132C	640	1.2V	101	-5	Lead-Free csBGA	132	COM
LCMXO640E-3BN256C	640	1.2V	159	-3	Lead-Free caBGA	256	COM
LCMXO640E-4BN256C	640	1.2V	159	-4	Lead-Free caBGA	256	COM
LCMXO640E-5BN256C	640	1.2V	159	-5	Lead-Free caBGA	256	COM
LCMXO640E-3FTN256C	640	1.2V	159	-3	Lead-Free ftBGA	256	COM
LCMXO640E-4FTN256C	640	1.2V	159	-4	Lead-Free ftBGA	256	COM
LCMXO640E-5FTN256C	640	1.2V	159	-5	Lead-Free ftBGA	256	COM

Lead-Free Packaging
Industrial

Part Number	LUTs	Supply Voltage	I/Os	Grade	Package	Pins	Temp.
LCMXO256C-3TN100I	256	1.8V/2.5V/3.3V	78	-3	Lead-Free TQFP	100	IND
LCMXO256C-4TN100I	256	1.8V/2.5V/3.3V	78	-4	Lead-Free TQFP	100	IND
LCMXO256C-3MN100I	256	1.8V/2.5V/3.3V	78	-3	Lead-Free csBGA	100	IND
LCMXO256C-4MN100I	256	1.8V/2.5V/3.3V	78	-4	Lead-Free csBGA	100	IND

Part Number	LUTs	Supply Voltage	I/Os	Grade	Package	Pins	Temp.
LCMXO640C-3TN100I	640	1.8V/2.5V/3.3V	74	-3	Lead-Free TQFP	100	IND
LCMXO640C-4TN100I	640	1.8V/2.5V/3.3V	74	-4	Lead-Free TQFP	100	IND
LCMXO640C-3MN100I	640	1.8V/2.5V/3.3V	74	-3	Lead-Free csBGA	100	IND
LCMXO640C-4MN100I	640	1.8V/2.5V/3.3V	74	-4	Lead-Free csBGA	100	IND
LCMXO640C-3TN144I	640	1.8V/2.5V/3.3V	113	-3	Lead-Free TQFP	144	IND
LCMXO640C-4TN144I	640	1.8V/2.5V/3.3V	113	-4	Lead-Free TQFP	144	IND
LCMXO640C-3MN132I	640	1.8V/2.5V/3.3V	101	-3	Lead-Free csBGA	132	IND
LCMXO640C-4MN132I	640	1.8V/2.5V/3.3V	101	-4	Lead-Free csBGA	132	IND
LCMXO640C-3BN256I	640	1.8V/2.5V/3.3V	159	-3	Lead-Free caBGA	256	IND
LCMXO640C-4BN256I	640	1.8V/2.5V/3.3V	159	-4	Lead-Free caBGA	256	IND
LCMXO640C-3FTN256I	640	1.8V/2.5V/3.3V	159	-3	Lead-Free ftBGA	256	IND
LCMXO640C-4FTN256I	640	1.8V/2.5V/3.3V	159	-4	Lead-Free ftBGA	256	IND

Part Number	LUTs	Supply Voltage	I/Os	Grade	Package	Pins	Temp.
LCMXO1200C-3TN100I	1200	1.8V/2.5V/3.3V	73	-3	Lead-Free TQFP	100	IND
LCMXO1200C-4TN100I	1200	1.8V/2.5V/3.3V	73	-4	Lead-Free TQFP	100	IND
LCMXO1200C-3TN144I	1200	1.8V/2.5V/3.3V	113	-3	Lead-Free TQFP	144	IND
LCMXO1200C-4TN144I	1200	1.8V/2.5V/3.3V	113	-4	Lead-Free TQFP	144	IND
LCMXO1200C-3MN132I	1200	1.8V/2.5V/3.3V	101	-3	Lead-Free csBGA	132	IND
LCMXO1200C-4MN132I	1200	1.8V/2.5V/3.3V	101	-4	Lead-Free csBGA	132	IND
LCMXO1200C-3BN256I	1200	1.8V/2.5V/3.3V	211	-3	Lead-Free caBGA	256	IND
LCMXO1200C-4BN256I	1200	1.8V/2.5V/3.3V	211	-4	Lead-Free caBGA	256	IND
LCMXO1200C-3FTN256I	1200	1.8V/2.5V/3.3V	211	-3	Lead-Free ftBGA	256	IND
LCMXO1200C-4FTN256I	1200	1.8V/2.5V/3.3V	211	-4	Lead-Free ftBGA	256	IND

Part Number	LUTs	Supply Voltage	I/Os	Grade	Package	Pins	Temp.
LCMXO2280C-3TN100I	2280	1.8V/2.5V/3.3V	73	-3	Lead-Free TQFP	100	IND
LCMXO2280C-4TN100I	2280	1.8V/2.5V/3.3V	73	-4	Lead-Free TQFP	100	IND
LCMXO2280C-3TN144I	2280	1.8V/2.5V/3.3V	113	-3	Lead-Free TQFP	144	IND
LCMXO2280C-4TN144I	2280	1.8V/2.5V/3.3V	113	-4	Lead-Free TQFP	144	IND
LCMXO2280C-3MN132I	2280	1.8V/2.5V/3.3V	101	-3	Lead-Free csBGA	132	IND
LCMXO2280C-4MN132I	2280	1.8V/2.5V/3.3V	101	-4	Lead-Free csBGA	132	IND
LCMXO2280C-3BN256I	2280	1.8V/2.5V/3.3V	211	-3	Lead-Free caBGA	256	IND
LCMXO2280C-4BN256I	2280	1.8V/2.5V/3.3V	211	-4	Lead-Free caBGA	256	IND
LCMXO2280C-3FTN256I	2280	1.8V/2.5V/3.3V	211	-3	Lead-Free ftBGA	256	IND
LCMXO2280C-4FTN256I	2280	1.8V/2.5V/3.3V	211	-4	Lead-Free ftBGA	256	IND
LCMXO2280C-3FTN324I	2280	1.8V/2.5V/3.3V	271	-3	Lead-Free ftBGA	324	IND
LCMXO2280C-4FTN324I	2280	1.8V/2.5V/3.3V	271	-4	Lead-Free ftBGA	324	IND

Part Number	LUTs	Supply Voltage	I/Os	Grade	Package	Pins	Temp.
LCMXO256E-3TN100I	256	1.2V	78	-3	Lead-Free TQFP	100	IND
LCMXO256E-4TN100I	256	1.2V	78	-4	Lead-Free TQFP	100	IND
LCMXO256E-3MN100I	256	1.2V	78	-3	Lead-Free csBGA	100	IND
LCMXO256E-4MN100I	256	1.2V	78	-4	Lead-Free csBGA	100	IND

Part Number	LUTs	Supply Voltage	I/Os	Grade	Package	Pins	Temp.
LCMXO640E-3TN100I	640	1.2V	74	-3	Lead-Free TQFP	100	IND
LCMXO640E-4TN100I	640	1.2V	74	-4	Lead-Free TQFP	100	IND
LCMXO640E-3MN100I	640	1.2V	74	-3	Lead-Free csBGA	100	IND
LCMXO640E-4MN100I	640	1.2V	74	-4	Lead-Free csBGA	100	IND
LCMXO640E-3TN144I	640	1.2V	113	-3	Lead-Free TQFP	144	IND
LCMXO640E-4TN144I	640	1.2V	113	-4	Lead-Free TQFP	144	IND
LCMXO640E-3MN132I	640	1.2V	101	-3	Lead-Free csBGA	132	IND
LCMXO640E-4MN132I	640	1.2V	101	-4	Lead-Free csBGA	132	IND
LCMXO640E-3BN256I	640	1.2V	159	-3	Lead-Free caBGA	256	IND
LCMXO640E-4BN256I	640	1.2V	159	-4	Lead-Free caBGA	256	IND
LCMXO640E-3FTN256I	640	1.2V	159	-3	Lead-Free ftBGA	256	IND
LCMXO640E-4FTN256I	640	1.2V	159	-4	Lead-Free ftBGA	256	IND

Part Number	LUTs	Supply Voltage	I/Os	Grade	Package	Pins	Temp.
LCMXO1200E-3TN100I	1200	1.2V	73	-3	Lead-Free TQFP	100	IND
LCMXO1200E-4TN100I	1200	1.2V	73	-4	Lead-Free TQFP	100	IND
LCMXO1200E-3TN144I	1200	1.2V	113	-3	Lead-Free TQFP	144	IND
LCMXO1200E-4TN144I	1200	1.2V	113	-4	Lead-Free TQFP	144	IND
LCMXO1200E-3MN132I	1200	1.2V	101	-3	Lead-Free csBGA	132	IND
LCMXO1200E-4MN132I	1200	1.2V	101	-4	Lead-Free csBGA	132	IND
LCMXO1200E-3BN256I	1200	1.2V	211	-3	Lead-Free caBGA	256	IND
LCMXO1200E-4BN256I	1200	1.2V	211	-4	Lead-Free caBGA	256	IND
LCMXO1200E-3FTN256I	1200	1.2V	211	-3	Lead-Free ftBGA	256	IND
LCMXO1200E-4FTN256I	1200	1.2V	211	-4	Lead-Free ftBGA	256	IND

Part Number	LUTs	Supply Voltage	I/Os	Grade	Package	Pins	Temp.
LCMXO2280E-3TN100I	2280	1.2V	73	-3	Lead-Free TQFP	100	IND
LCMXO2280E-4TN100I	2280	1.2V	73	-4	Lead-Free TQFP	100	IND
LCMXO2280E-3TN144I	2280	1.2V	113	-3	Lead-Free TQFP	144	IND
LCMXO2280E-4TN144I	2280	1.2V	113	-4	Lead-Free TQFP	144	IND
LCMXO2280E-3MN132I	2280	1.2V	101	-3	Lead-Free csBGA	132	IND
LCMXO2280E-4MN132I	2280	1.2V	101	-4	Lead-Free csBGA	132	IND
LCMXO2280E-3BN256I	2280	1.2V	211	-3	Lead-Free caBGA	256	IND
LCMXO2280E-4BN256I	2280	1.2V	211	-4	Lead-Free caBGA	256	IND
LCMXO2280E-3FTN256I	2280	1.2V	211	-3	Lead-Free ftBGA	256	IND
LCMXO2280E-4FTN256I	2280	1.2V	211	-4	Lead-Free ftBGA	256	IND
LCMXO2280E-3FTN324I	2280	1.2V	271	-3	Lead-Free ftBGA	324	IND
LCMXO2280E-4FTN324I	2280	1.2V	271	-4	Lead-Free ftBGA	324	IND

Revision History

Date	Version	Section	Change Summary
February 2005	01.0	—	Initial release.
October 2005	01.1	Introduction	Distributed RAM information in family table updated. Added footnote 1 - fpBGA packaging to the family selection guide.
		Architecture	sysIO Buffer section updated.
			Hot Socketing section updated.
			Sleep Mode section updated.
			SLEEP Pin Characteristics section updated.
			Oscillator section updated.
			Security section updated.
		DC and Switching Characteristics	Recommended Operating Conditions table updated.
			DC Electrical Characteristics table updated.
			Supply Current (Sleep Mode) table added with LCMXO256/640 data.
			Supply Current (Standby) table updated with LCMXO256/640 data.
			Initialization Supply Current table updated with LCMXO256/640 data.
			Programming and Erase Flash Supply Current table updated with LCMXO256/640 data.
			Register-to-Register Performance table updated (rev. A 0.16).
			External Switching Characteristics table updated (rev. A 0.16).
			Internal Timing Parameter table updated (rev. A 0.16).
			Family Timing Adders updated (rev. A 0.16).
			sysCLOCK Timing updated (rev. A 0.16).
			MachXO "C" Sleep Mode Timing updated (A 0.16).
			JTAG Port Timing Specification updated (rev. A 0.16).
		Pinout Information	SLEEPIN description updated.
			Pin Information Summary updated.
			Power Supply and NC Connection table has been updated.
Logic Signal Connection section has been updated to include all devices/packages.			
Ordering Information	Part Number Description section has been updated.		
	Ordering Part Number section has been updated (added LCMXO256C/LCMXO640C "4W").		
Supplemental Information	MachXO Density Migration Technical Note (TN1097) added.		
November 2005	01.2	Pinout Information	Added "Power Supply and NC Connections" summary information for LCMXO1200 and LCMXO2280 in 100 TQFP package.
December 2005	01.3	DC and Switching Characteristics	Supply Current (Standby) table updated with LCMXO1200/2280 data.
		Ordering Information	Ordering Part Number section updated (added LCMXO2280C "4W").
April 2006	02.0	Introduction	Introduction paragraphs updated.
		Architecture	Architecture Overview paragraphs updated.