



Welcome to [E-XFL.COM](http://E-XFL.COM)

## Understanding [Embedded - FPGAs \(Field Programmable Gate Array\)](#)

Embedded - FPGAs, or Field Programmable Gate Arrays, are advanced integrated circuits that offer unparalleled flexibility and performance for digital systems. Unlike traditional fixed-function logic devices, FPGAs can be programmed and reprogrammed to execute a wide array of logical operations, enabling customized functionality tailored to specific applications. This reprogrammability allows developers to iterate designs quickly and implement complex functions without the need for custom hardware.

## Applications of Embedded - FPGAs

The versatility of Embedded - FPGAs makes them indispensable in numerous fields. In telecommunications.

### Details

Product Status	Obsolete
Number of LABs/CLBs	285
Number of Logic Elements/Cells	2280
Total RAM Bits	28262
Number of I/O	113
Number of Gates	-
Voltage - Supply	1.14V ~ 1.26V
Mounting Type	Surface Mount
Operating Temperature	-40°C ~ 100°C (Tj)
Package / Case	144-LQFP
Supplier Device Package	144-TQFP (20x20)
Purchase URL	<a href="https://www.e-xfl.com/product-detail/lattice-semiconductor/lcmxo2280e-3t144i">https://www.e-xfl.com/product-detail/lattice-semiconductor/lcmxo2280e-3t144i</a>

**Figure 2-3. Top View of the MachXO256 Device**

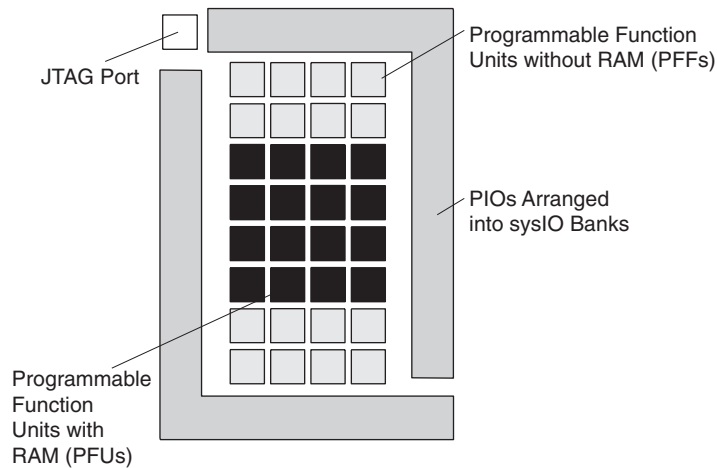

**PFU Blocks**

The core of the MachXO devices consists of PFU and PFF blocks. The PFUs can be programmed to perform Logic, Arithmetic, Distributed RAM, and Distributed ROM functions. PFF blocks can be programmed to perform Logic, Arithmetic, and Distributed ROM functions. Except where necessary, the remainder of this data sheet will use the term PFU to refer to both PFU and PFF blocks.

Each PFU block consists of four interconnected Slices, numbered 0-3 as shown in Figure 2-4. There are 53 inputs and 25 outputs associated with each PFU block.

**Figure 2-4. PFU Diagram**

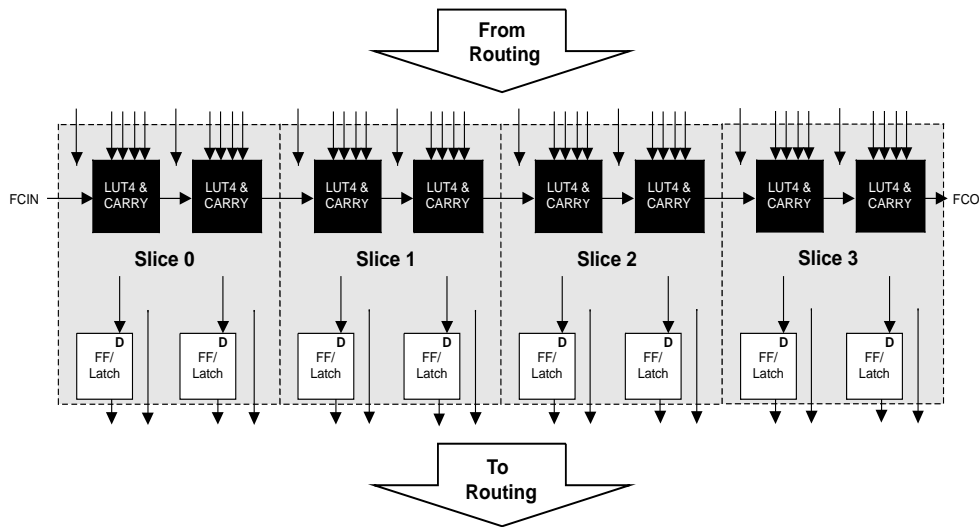

**Slice**

Each Slice contains two LUT4 lookup tables feeding two registers (programmed to be in FF or Latch mode), and some associated logic that allows the LUTs to be combined to perform functions such as LUT5, LUT6, LUT7, and LUT8. There is control logic to perform set/reset functions (programmable as synchronous/asynchronous), clock select, chip-select, and wider RAM/ROM functions. Figure 2-5 shows an overview of the internal logic of the Slice. The registers in the Slice can be configured for positive/negative and edge/level clocks.

There are 14 input signals: 13 signals from routing and one from the carry-chain (from the adjacent Slice/PFU). There are 7 outputs: 6 to the routing and one to the carry-chain (to the adjacent Slice/PFU). Table 2-1 lists the signals associated with each Slice.

**Figure 2-5. Slice Diagram**

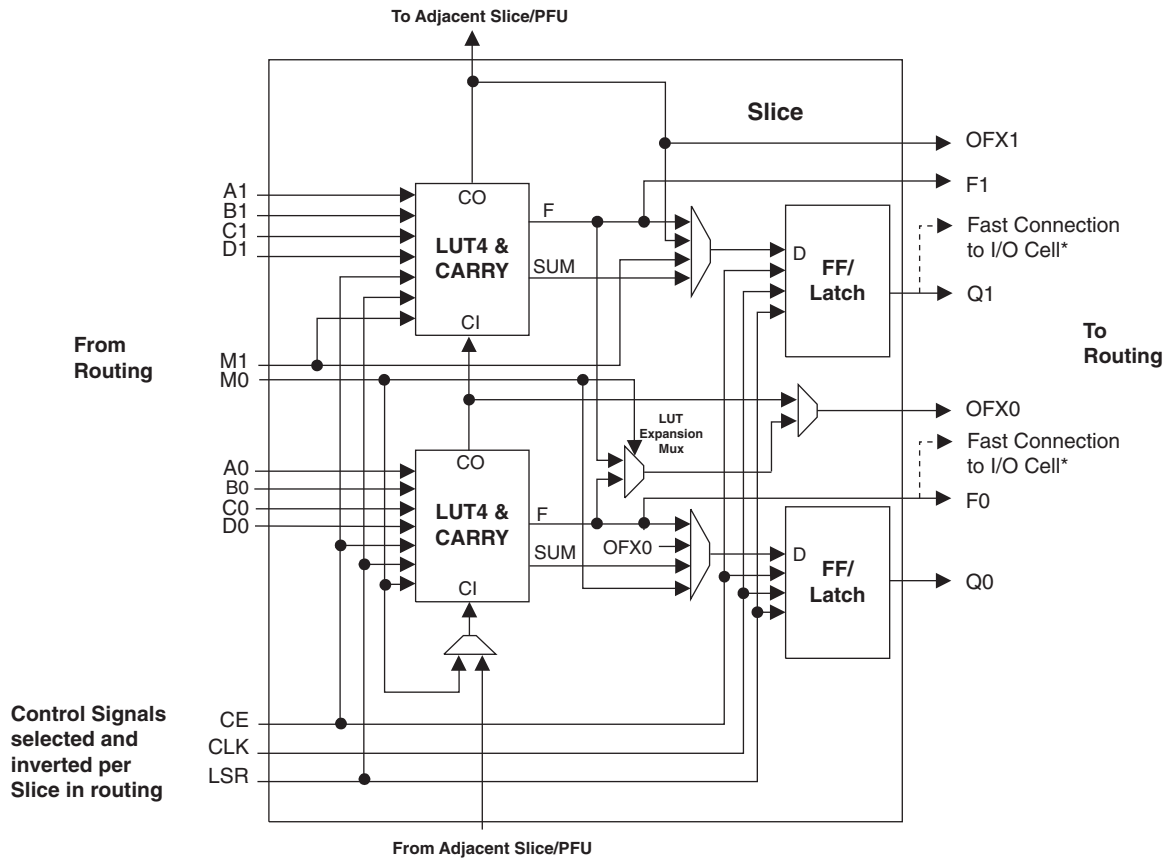

Notes:  
 Some inter-Slice signals are not shown.  
 \* Only PFUs at the edges have fast connections to the I/O cell.

**Table 2-1. Slice Signal Descriptions**

Function	Type	Signal Names	Description
Input	Data signal	A0, B0, C0, D0	Inputs to LUT4
Input	Data signal	A1, B1, C1, D1	Inputs to LUT4
Input	Multi-purpose	M0/M1	Multipurpose Input
Input	Control signal	CE	Clock Enable
Input	Control signal	LSR	Local Set/Reset
Input	Control signal	CLK	System Clock
Input	Inter-PFU signal	FCIN	Fast Carry In <sup>1</sup>
Output	Data signals	F0, F1	LUT4 output register bypass signals
Output	Data signals	Q0, Q1	Register Outputs
Output	Data signals	OFX0	Output of a LUT5 MUX
Output	Data signals	OFX1	Output of a LUT6, LUT7, LUT8 <sup>2</sup> MUX depending on the Slice
Output	Inter-PFU signal	FCO	Fast Carry Out <sup>1</sup>

1. See Figure 2-4 for connection details.  
 2. Requires two PFUs.

**Figure 2-6. Distributed Memory Primitives**

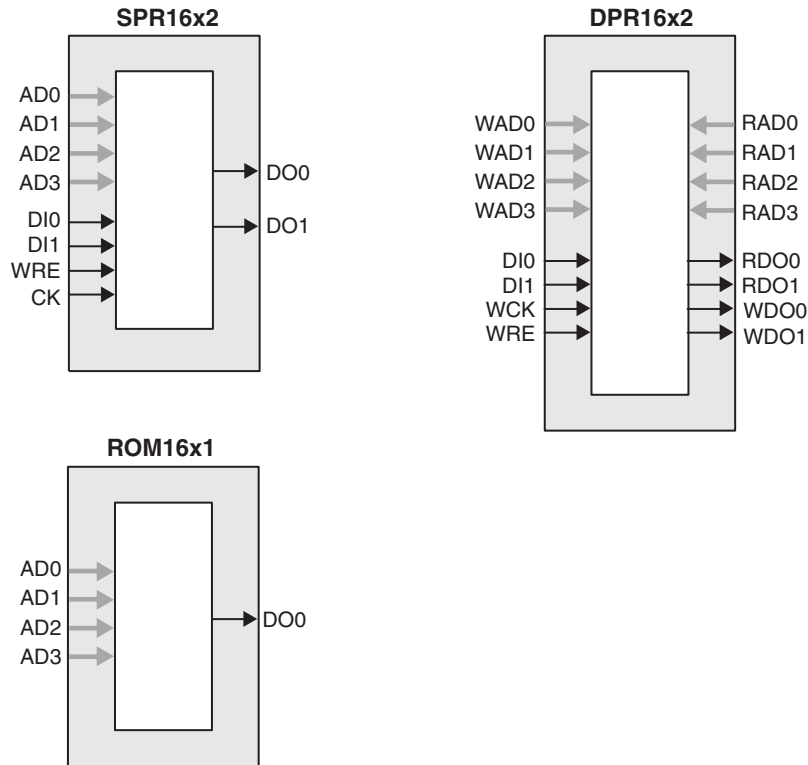

**ROM Mode:** The ROM mode uses the same principal as the RAM modes, but without the Write port. Pre-loading is accomplished through the programming interface during configuration.

**PFU Modes of Operation**

Slices can be combined within a PFU to form larger functions. Table 2-4 tabulates these modes and documents the functionality possible at the PFU level.

**Table 2-4. PFU Modes of Operation**

Logic	Ripple	RAM	ROM
LUT 4x8 or MUX 2x1 x 8	2-bit Add x 4	SPR16x2 x 4 DPR16x2 x 2	ROM16x1 x 8
LUT 5x4 or MUX 4x1 x 4	2-bit Sub x 4	SPR16x4 x 2 DPR16x4 x 1	ROM16x2 x 4
LUT 6x 2 or MUX 8x1 x 2	2-bit Counter x 4	SPR16x8 x 1	ROM16x4 x 2
LUT 7x1 or MUX 16x1 x 1	2-bit Comp x 4		ROM16x8 x 1

**Routing**

There are many resources provided in the MachXO devices to route signals individually or as buses with related control signals. The routing resources consist of switching circuitry, buffers and metal interconnect (routing) segments.

The inter-PFU connections are made with three different types of routing resources: x1 (spans two PFUs), x2 (spans three PFUs) and x6 (spans seven PFUs). The x1, x2, and x6 connections provide fast and efficient connections in the horizontal and vertical directions.

Figure 2-8. Primary Clocks for MachXO1200 and MachXO2280 Devices

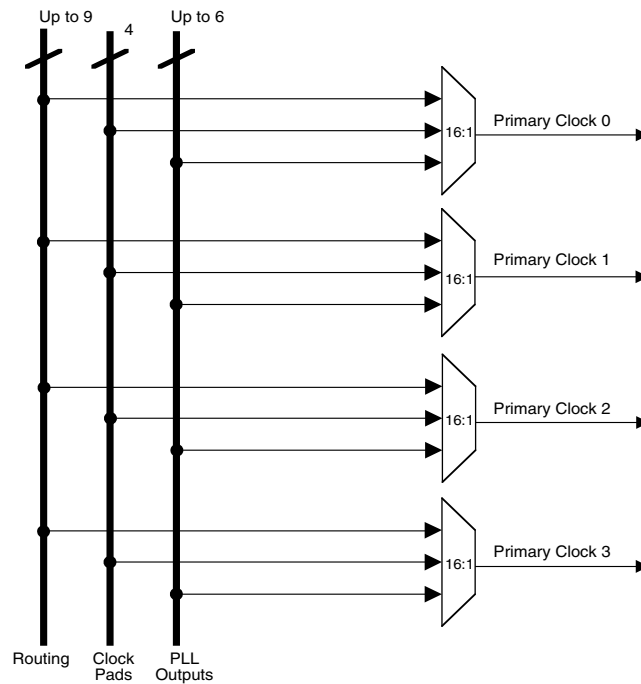

Four secondary clocks are generated from four 16:1 muxes as shown in Figure 2-9. Four of the secondary clock sources come from dual function clock pins and 12 come from internal routing.

Figure 2-9. Secondary Clocks for MachXO Devices

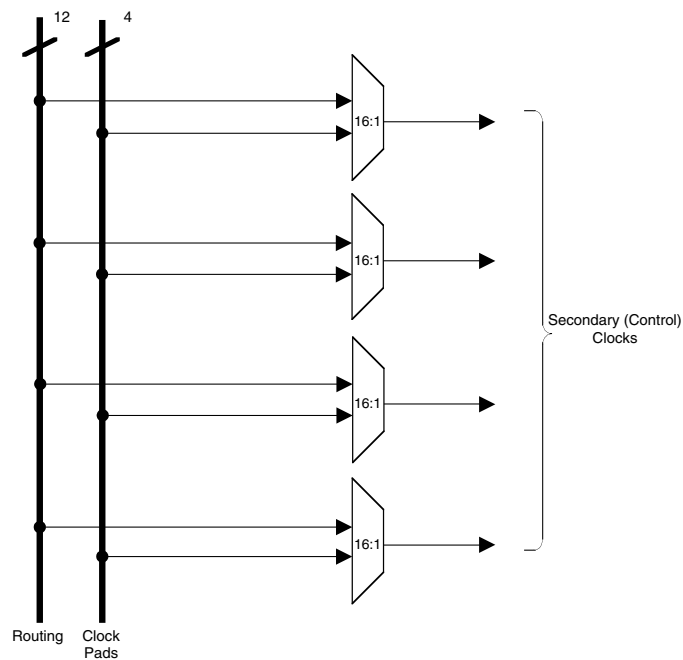

**Table 2-8. I/O Support Device by Device**

	MachXO256	MachXO640	MachXO1200	MachXO2280
Number of I/O Banks	2	4	8	8
Type of Input Buffers	Single-ended (all I/O Banks)	Single-ended (all I/O Banks)	Single-ended (all I/O Banks) Differential Receivers (all I/O Banks)	Single-ended (all I/O Banks) Differential Receivers (all I/O Banks)
Types of Output Buffers	Single-ended buffers with complementary outputs (all I/O Banks)	Single-ended buffers with complementary outputs (all I/O Banks)	Single-ended buffers with complementary outputs (all I/O Banks) Differential buffers with true LVDS outputs (50% on left and right side)	Single-ended buffers with complementary outputs (all I/O Banks) Differential buffers with true LVDS outputs (50% on left and right side)
Differential Output Emulation Capability	All I/O Banks	All I/O Banks	All I/O Banks	All I/O Banks
PCI Support	No	No	Top side only	Top side only

**Table 2-9. Supported Input Standards**

Input Standard	VCCIO (Typ.)				
	3.3V	2.5V	1.8V	1.5V	1.2V
<b>Single Ended Interfaces</b>					
LVTTTL	Yes	Yes	Yes	Yes	Yes
LVC MOS33	Yes	Yes	Yes	Yes	Yes
LVC MOS25	Yes	Yes	Yes	Yes	Yes
LVC MOS18			Yes		
LVC MOS15				Yes	
LVC MOS12	Yes	Yes	Yes	Yes	Yes
PCI <sup>1</sup>	Yes				
<b>Differential Interfaces</b>					
BLVDS <sup>2</sup> , LVDS <sup>2</sup> , LVPECL <sup>2</sup> , RSDS <sup>2</sup>	Yes	Yes	Yes	Yes	Yes

1. Top Banks of MachXO1200 and MachXO2280 devices only.

2. MachXO1200 and MachXO2280 devices only.

the system. These capabilities make the MachXO ideal for many multiple power supply and hot-swap applications.

## Sleep Mode

The MachXO “C” devices ( $V_{CC} = 1.8/2.5/3.3V$ ) have a sleep mode that allows standby current to be reduced dramatically during periods of system inactivity. Entry and exit to Sleep mode is controlled by the SLEEPN pin.

During Sleep mode, the logic is non-operational, registers and EBR contents are not maintained, and I/Os are tri-stated. Do not enter Sleep mode during device programming or configuration operation. In Sleep mode, power supplies are in their normal operating range, eliminating the need for external switching of power supplies. Table 2-11 compares the characteristics of Normal, Off and Sleep modes.

**Table 2-11. Characteristics of Normal, Off and Sleep Modes**

Characteristic	Normal	Off	Sleep
SLEEPN Pin	High	—	Low
Static Icc	Typical <10mA	0	Typical <100uA
I/O Leakage	<10μA	<1mA	<10μA
Power Supplies VCC/VCCIO/VCCAUX	Normal Range	0	Normal Range
Logic Operation	User Defined	Non Operational	Non operational
I/O Operation	User Defined	Tri-state	Tri-state
JTAG and Programming circuitry	Operational	Non-operational	Non-operational
EBR Contents and Registers	Maintained	Non-maintained	Non-maintained

## SLEEPN Pin Characteristics

The SLEEPN pin behaves as an LVCMOS input with the voltage standard appropriate to the VCC supply for the device. This pin also has a weak pull-up, along with a Schmidt trigger and glitch filter to prevent false triggering. An external pull-up to VCC is recommended when Sleep Mode is not used to ensure the device stays in normal operation mode. Typically, the device enters sleep mode several hundred nanoseconds after SLEEPN is held at a valid low and restarts normal operation as specified in the Sleep Mode Timing table. The AC and DC specifications portion of this data sheet shows a detailed timing diagram.

## Oscillator

Every MachXO device has an internal CMOS oscillator. The oscillator can be routed as an input clock to the clock tree or to general routing resources. The oscillator frequency can be divided by internal logic. There is a dedicated programming bit to enable/disable the oscillator. The oscillator frequency ranges from 18MHz to 26MHz.

## Configuration and Testing

The following section describes the configuration and testing features of the MachXO family of devices.

### IEEE 1149.1-Compliant Boundary Scan Testability

All MachXO devices have boundary scan cells that are accessed through an IEEE 1149.1 compliant test access port (TAP). This allows functional testing of the circuit board, on which the device is mounted, through a serial scan path that can access all critical logic nodes. Internal registers are linked internally, allowing test data to be shifted in and loaded directly onto test nodes, or test data to be captured and shifted out for verification. The test access port consists of dedicated I/Os: TDI, TDO, TCK and TMS. The test access port shares its power supply with one of the VCCIO Banks (MachXO256:  $V_{CCIO1}$ ; MachXO640:  $V_{CCIO2}$ ; MachXO1200 and MachXO2280:  $V_{CCIO5}$ ) and can operate with LVCMOS3.3, 2.5, 1.8, 1.5, and 1.2 standards.

For more details on boundary scan test, please see information regarding additional technical documentation at the end of this data sheet.

### Supply Current (Sleep Mode)<sup>1, 2</sup>

Symbol	Parameter	Device	Typ. <sup>3</sup>	Max.	Units
I <sub>CC</sub>	Core Power Supply	LCMXO256C	12	25	μA
		LCMXO640C	12	25	μA
		LCMXO1200C	12	25	μA
		LCMXO2280C	12	25	μA
I <sub>CCAUX</sub>	Auxiliary Power Supply	LCMXO256C	1	15	μA
		LCMXO640C	1	25	μA
		LCMXO1200C	1	45	μA
		LCMXO2280C	1	85	μA
I <sub>CCIO</sub>	Bank Power Supply <sup>4</sup>	All LCMXO 'C' Devices	2	30	μA

1. Assumes all inputs are configured as LVCMOS and held at the V<sub>CCIO</sub> or GND.
2. Frequency = 0MHz.
3. T<sub>A</sub> = 25°C, power supplies at nominal voltage.
4. Per Bank.

### Supply Current (Standby)<sup>1, 2, 3, 4</sup>

#### Over Recommended Operating Conditions

Symbol	Parameter	Device	Typ. <sup>5</sup>	Units
I <sub>CC</sub>	Core Power Supply	LCMXO256C	7	mA
		LCMXO640C	9	mA
		LCMXO1200C	14	mA
		LCMXO2280C	20	mA
		LCMXO256E	4	mA
		LCMXO640E	6	mA
		LCMXO1200E	10	mA
		LCMXO2280E	12	mA
I <sub>CCAUX</sub>	Auxiliary Power Supply V <sub>CCAUX</sub> = 3.3V	LCMXO256E/C	5	mA
		LCMXO640E/C	7	mA
		LCMXO1200E/C	12	mA
		LCMXO2280E/C	13	mA
I <sub>CCIO</sub>	Bank Power Supply <sup>6</sup>	All devices	2	mA

1. For further information on supply current, please see details of additional technical documentation at the end of this data sheet.
2. Assumes all outputs are tristated, all inputs are configured as LVCMOS and held at V<sub>CCIO</sub> or GND.
3. Frequency = 0MHz.
4. User pattern = blank.
5. T<sub>J</sub> = 25°C, power supplies at nominal voltage.
6. Per Bank. V<sub>CCIO</sub> = 2.5V. Does not include pull-up/pull-down.



For further information on LVPECL, BLVDS and other differential interfaces please see details of additional technical documentation at the end of the data sheet.

## RSDS

The MachXO family supports the differential RSDS standard. The output standard is emulated using complementary LVCMOS outputs in conjunction with a parallel resistor across the driver outputs on all the devices. The RSDS input standard is supported by the LVDS differential input buffer on certain devices. The scheme shown in Figure 3-4 is one possible solution for RSDS standard implementation. Use LVDS25E mode with suggested resistors for RSDS operation. Resistor values in Figure 3-4 are industry standard values for 1% resistors.

**Figure 3-4. RSDS (Reduced Swing Differential Standard)**

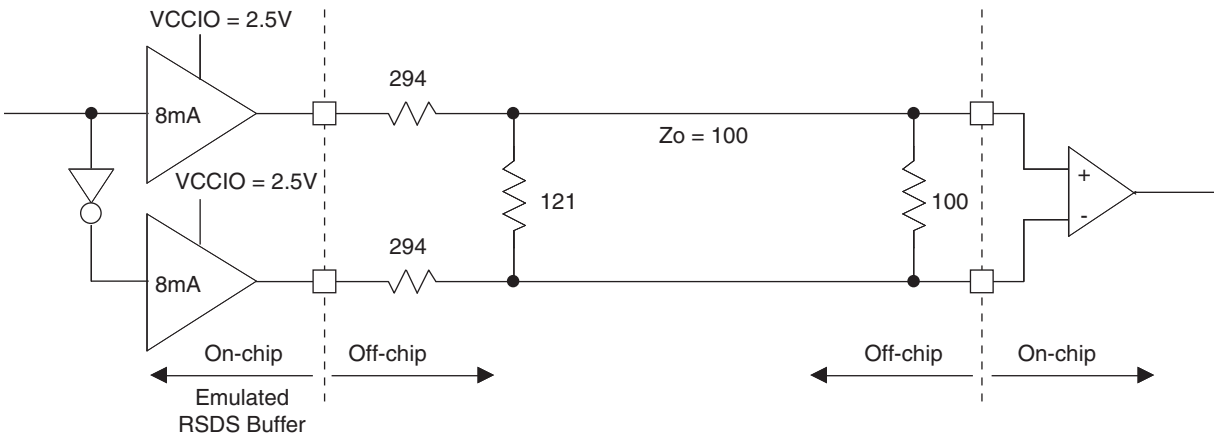

**Table 3-4. RSDS DC Conditions**

Parameter	Description	Typical	Units
$Z_{OUT}$	Output impedance	20	Ohms
$R_S$	Driver series resistor	294	Ohms
$R_P$	Driver parallel resistor	121	Ohms
$R_T$	Receiver termination	100	Ohms
$V_{OH}$	Output high voltage	1.35	V
$V_{OL}$	Output low voltage	1.15	V
$V_{OD}$	Output differential voltage	0.20	V
$V_{CM}$	Output common mode voltage	1.25	V
$Z_{BACK}$	Back impedance	101.5	Ohms
$I_{DC}$	DC output current	3.66	mA

## MachXO Internal Timing Parameters<sup>1</sup>

Over Recommended Operating Conditions

Parameter	Description	-5		-4		-3		Units
		Min.	Max.	Min.	Max.	Min.	Max.	
<b>PFU/PFF Logic Mode Timing</b>								
t <sub>LUT4_PFU</sub>	LUT4 delay (A to D inputs to F output)	—	0.28	—	0.34	—	0.39	ns
t <sub>LUT6_PFU</sub>	LUT6 delay (A to D inputs to OFX output)	—	0.44	—	0.53	—	0.62	ns
t <sub>LSR_PFU</sub>	Set/Reset to output of PFU	—	0.90	—	1.08	—	1.26	ns
t <sub>SUM_PFU</sub>	Clock to Mux (M0,M1) input setup time	0.10	—	0.13	—	0.15	—	ns
t <sub>HM_PFU</sub>	Clock to Mux (M0,M1) input hold time	-0.05	—	-0.06	—	-0.07	—	ns
t <sub>SUD_PFU</sub>	Clock to D input setup time	0.13	—	0.16	—	0.18	—	ns
t <sub>HD_PFU</sub>	Clock to D input hold time	-0.03	—	-0.03	—	-0.04	—	ns
t <sub>CK2Q_PFU</sub>	Clock to Q delay, D-type register configuration	—	0.40	—	0.48	—	0.56	ns
t <sub>LE2Q_PFU</sub>	Clock to Q delay latch configuration	—	0.53	—	0.64	—	0.74	ns
t <sub>LD2Q_PFU</sub>	D to Q throughput delay when latch is enabled	—	0.55	—	0.66	—	0.77	ns
<b>PFU Dual Port Memory Mode Timing</b>								
t <sub>CORAM_PFU</sub>	Clock to Output	—	0.40	—	0.48	—	0.56	ns
t <sub>SUDATA_PFU</sub>	Data Setup Time	-0.18	—	-0.22	—	-0.25	—	ns
t <sub>HDATA_PFU</sub>	Data Hold Time	0.28	—	0.34	—	0.39	—	ns
t <sub>SUADDR_PFU</sub>	Address Setup Time	-0.46	—	-0.56	—	-0.65	—	ns
t <sub>HADDR_PFU</sub>	Address Hold Time	0.71	—	0.85	—	0.99	—	ns
t <sub>SUWREN_PFU</sub>	Write/Read Enable Setup Time	-0.22	—	-0.26	—	-0.30	—	ns
t <sub>HWREN_PFU</sub>	Write/Read Enable Hold Time	0.33	—	0.40	—	0.47	—	ns
<b>PIO Input/Output Buffer Timing</b>								
t <sub>IN_PIO</sub>	Input Buffer Delay	—	0.75	—	0.90	—	1.06	ns
t <sub>OUT_PIO</sub>	Output Buffer Delay	—	1.29	—	1.54	—	1.80	ns
<b>EBR Timing (1200 and 2280 Devices Only)</b>								
t <sub>CO_EBR</sub>	Clock to output from Address or Data with no output register	—	2.24	—	2.69	—	3.14	ns
t <sub>COO_EBR</sub>	Clock to output from EBR output Register	—	0.54	—	0.64	—	0.75	ns
t <sub>SUDATA_EBR</sub>	Setup Data to EBR Memory	-0.26	—	-0.31	—	-0.37	—	ns
t <sub>HDATA_EBR</sub>	Hold Data to EBR Memory	0.41	—	0.49	—	0.57	—	ns
t <sub>SUADDR_EBR</sub>	Setup Address to EBR Memory	-0.26	—	-0.31	—	-0.37	—	ns
t <sub>HADDR_EBR</sub>	Hold Address to EBR Memory	0.41	—	0.49	—	0.57	—	ns
t <sub>SUWREN_EBR</sub>	Setup Write/Read Enable to EBR Memory	-0.17	—	-0.20	—	-0.23	—	ns
t <sub>HWREN_EBR</sub>	Hold Write/Read Enable to EBR Memory	0.26	—	0.31	—	0.36	—	ns
t <sub>SUCE_EBR</sub>	Clock Enable Setup Time to EBR Output Register	0.19	—	0.23	—	0.27	—	ns
t <sub>HCE_EBR</sub>	Clock Enable Hold Time to EBR Output Register	-0.13	—	-0.16	—	-0.18	—	ns
t <sub>RSTO_EBR</sub>	Reset To Output Delay Time from EBR Output Register	—	1.03	—	1.23	—	1.44	ns
<b>PLL Parameters (1200 and 2280 Devices Only)</b>								
t <sub>RSTREC</sub>	Reset Recovery to Rising Clock	1.00	—	1.00	—	1.00	—	ns
t <sub>RSTSU</sub>	Reset Signal Setup Time	1.00	—	1.00	—	1.00	—	ns

1. Internal parameters are characterized but not tested on every device.

Rev. A 0.19

## sysCLOCK PLL Timing

### Over Recommended Operating Conditions

Parameter	Descriptions	Conditions	Min.	Max.	Units
f <sub>IN</sub>	Input Clock Frequency (CLKI, CLKFB)		25	420	MHz
		Input Divider (M) = 1; Feedback Divider (N) <= 4 <sup>5,6</sup>	18	25	MHz
f <sub>OUT</sub>	Output Clock Frequency (CLKOP, CLKOS)		25	420	MHz
f <sub>OUT2</sub>	K-Divider Output Frequency (CLKOK)		0.195	210	MHz
f <sub>VCO</sub>	PLL VCO Frequency		420	840	MHz
f <sub>PDF</sub>	Phase Detector Input Frequency		25	—	MHz
		Input Divider (M) = 1; Feedback Divider (N) <= 4 <sup>5,6</sup>	18	25	MHz
<b>AC Characteristics</b>					
t <sub>DT</sub>	Output Clock Duty Cycle	Default duty cycle selected <sup>3</sup>	45	55	%
t <sub>PH</sub> <sup>4</sup>	Output Phase Accuracy		—	0.05	UI
t <sub>OPJIT</sub> <sup>1</sup>	Output Clock Period Jitter	f <sub>OUT</sub> ≥ 100 MHz	—	+/-120	ps
		f <sub>OUT</sub> < 100 MHz	—	0.02	UIPP
t <sub>SK</sub>	Input Clock to Output Clock Skew	Divider ratio = integer	—	+/-200	ps
t <sub>W</sub>	Output Clock Pulse Width	At 90% or 10% <sup>3</sup>	1	—	ns
t <sub>LOCK</sub> <sup>2</sup>	PLL Lock-in Time		—	150	μs
t <sub>PA</sub>	Programmable Delay Unit		100	450	ps
t <sub>IPJIT</sub>	Input Clock Period Jitter	f <sub>OUT</sub> ≥ 100 MHz	—	+/-200	ps
		f <sub>OUT</sub> < 100 MHz	—	0.02	UI
t <sub>FBKDLY</sub>	External Feedback Delay		—	10	ns
t <sub>HI</sub>	Input Clock High Time	90% to 90%	0.5	—	ns
t <sub>LO</sub>	Input Clock Low Time	10% to 10%	0.5	—	ns
t <sub>RST</sub>	RST Pulse Width		10	—	ns

1. Jitter sample is taken over 10,000 samples of the primary PLL output with a clean reference clock.

2. Output clock is valid after t<sub>LOCK</sub> for PLL reset and dynamic delay adjustment.

3. Using LVDS output buffers.

4. CLKOS as compared to CLKOP output.

5. When using an input frequency less than 25 MHz the output frequency must be less than or equal to 4 times the input frequency.

6. The on-chip oscillator can be used to provide reference clock input to the PLL provided the output frequency restriction for clock inputs below 25 MHz are followed.

Rev. A 0.19

**LCMX0256 and LCMX0640 Logic Signal Connections: 100 csBGA**

LCMX0256					LCMX0640				
Ball Number	Ball Function	Bank	Dual Function	Differential	Ball Number	Ball Function	Bank	Dual Function	Differential
B1	PL2A	1		T	B1	PL2A	3		T
C1	PL2B	1		C	C1	PL2C	3		T
D2	PL3A	1		T	D2	PL2B	3		C
D1	PL3B	1		C	D1	PL2D	3		C
C2	PL3C	1		T	C2	PL3A	3		T
E1	PL3D	1		C	E1	PL3B	3		C
E2	PL4A	1		T	E2	PL3C	3		T
F1	PL4B	1		C	F1	PL3D	3		C
F2	PL5A	1		T	F2	PL4A	3		
G2	PL5B	1		C	G2	PL4C	3		T
H1	GNDIO1	1			H1	GNDIO3	3		
H2	PL5C	1		T	H2	PL4D	3		C
J1	PL5D	1	GSRN	C	J1	PL5B	3	GSRN	
J2	PL6A	1		T	J2	PL7B	3		
K1	PL6B	1	TSALL	C	K1	PL8C	3	TSALL	T
K2	PL7A	1		T	K2	PL8D	3		C
L1	PL7B	1		C	L1	PL9A	3		
L2	PL7C	1		T	L2	PL9C	3		
M1	PL7D	1		C	M1	PL10A	3		
M2	PL8A	1		T	M2	PL10C	3		
N1	PL8B	1		C	N1	PL11A	3		
M3	PL9A	1		T	M3	PL11C	3		
N2	GNDIO1	1			N2	GNDIO3	3		
P2	TMS	1	TMS		P2	TMS	2	TMS	
P3	PL9B	1		C	P3	PB2C	2		
N4	TCK	1	TCK		N4	TCK	2	TCK	
P4	PB2A	1		T	P4	VCCIO2	2		
N3	PB2B	1		C	N3	GNDIO2	2		
P5	TDO	1	TDO		P5	TDO	2	TDO	
N5	PB2C	1		T	N5	PB4C	2		
P6	TDI	1	TDI		P6	TDI	2	TDI	
N6	PB2D	1		C	N6	PB4E	2		
P7	VCC	-			P7	VCC	-		
N7	PB3A	1	PCLK1_1**	T	N7	PB5B	2	PCLK2_1**	
P8	PB3B	1		C	P8	PB5D	2		
N8	PB3C	1	PCLK1_0**	T	N8	PB6B	2	PCLK2_0**	
P9	PB3D	1		C	P9	PB6C	2		
N10	GNDIO1	1			N10	GNDIO2	2		
P11	PB4A	1		T	P11	PB8B	2		
N11	PB4B	1		C	N11	PB8C	2		T
P12	PB4C	1		T	P12	PB8D	2		C
N12	PB4D	1		C	N12	PB9A	2		

## LCMXO640, LCMXO1200 and LCMXO2280 Logic Signal Connections: 132 csBGA

LCMXO640					LCMXO1200					LCMXO2280				
Ball #	Ball Function	Bank	Dual Function	Differential	Ball #	Ball Function	Bank	Dual Function	Differential	Ball #	Ball Function	Bank	Dual Function	Differential
B1	PL2A	3		T	B1	PL2A	7		T	B1	PL2A	7	LUM0_PLLT_FB_A	T
C1	PL2B	3		C	C1	PL3C	7		T	C1	PL3C	7	LUM0_PLLT_IN_A	T
B2	PL2C	3		T	B2	PL2B	7		C	B2	PL2B	7	LUM0_PLLC_FB_A	C
C2	PL2D	3		C	C2	PL4A	7		T*	C2	PL4A	7		T*
C3	PL3A	3		T	C3	PL3D	7		C	C3	PL3D	7	LUM0_PLLC_IN_A	C
D1	PL3B	3		C	D1	PL4B	7		C*	D1	PL4B	7		C*
D3	PL3D	3			D3	PL4C	7			D3	PL4C	7		
E1	GNDIO3	3			E1	GNDIO7	7			E1	GNDIO7	7		
E2	PL5A	3		T	E2	PL6A	7		T*	E2	PL7A	7		T*
E3	PL5B	3	GSRN	C	E3	PL6B	7	GSRN	C*	E3	PL7B	7	GSRN	C*
F2	PL5D	3			F2	PL6D	7			F2	PL7D	7		
F3	PL6B	3			F3	PL7C	7		T	F3	PL9C	7		T
G1	PL6C	3		T	G1	PL7D	7		C	G1	PL9D	7		C
G2	PL6D	3		C	G2	PL8C	7		T	G2	PL10C	7		T
G3	PL7A	3		T	G3	PL8D	7		C	G3	PL10D	7		C
H2	PL7B	3		C	H2	PL10A	6		T*	H2	PL12A	6		T*
H1	PL7C	3			H1	PL10B	6		C*	H1	PL12B	6		C*
H3	VCC	-			H3	VCC	-			H3	VCC	-		
J1	PL8A	3			J1	PL11B	6			J1	PL14D	6		C
J2	PL8C	3	TSALL		J2	PL11C	6	TSALL	T	J2	PL14C	6	TSALL	T
J3	PL9A	3		T	J3	PL11D	6		C	J3	PL14B	6		
K2	PL9B	3		C	K2	PL12A	6		T*	K2	PL15A	6		T*
K1	PL9C	3			K1	PL12B	6		C*	K1	PL15B	6		C*
L2	GNDIO3	3			L2	GNDIO6	6			L2	GNDIO6	6		
L1	PL10A	3		T	L1	PL14A	6	LLM0_PLLT_FB_A	T*	L1	PL17A	6	LLM0_PLLT_FB_A	T*
L3	PL10B	3		C	L3	PL14B	6	LLM0_PLLC_FB_A	C*	L3	PL17B	6	LLM0_PLLC_FB_A	C*
M1	PL11A	3		T	M1	PL15A	6	LLM0_PLLT_IN_A	T*	M1	PL18A	6	LLM0_PLLT_IN_A	T*
N1	PL11B	3		C	N1	PL16A	6		T	N1	PL19A	6		T
M2	PL11C	3		T	M2	PL15B	6	LLM0_PLLC_IN_A	C*	M2	PL18B	6	LLM0_PLLC_IN_A	C*
P1	PL11D	3		C	P1	PL16B	6		C	P1	PL19B	6		C
P2	GNDIO2	2			P2	GNDIO5	5			P2	GNDIO5	5		
P3	TMS	2	TMS		P3	TMS	5	TMS		P3	TMS	5	TMS	
M3	PB2C	2		T	M3	PB2C	5		T	M3	PB2A	5		T
N3	PB2D	2		C	N3	PB2D	5		C	N3	PB2B	5		C
P4	TCK	2	TCK		P4	TCK	5	TCK		P4	TCK	5	TCK	
M4	PB3B	2			M4	PB3B	5			M4	PB3B	5		
N4	PB3C	2		T	N4	PB4A	5		T	N4	PB4A	5		T
P5	PB3D	2		C	P5	PB4B	5		C	P5	PB4B	5		C
N5	TDO	2	TDO		N5	TDO	5	TDO		N5	TDO	5	TDO	
M5	TDI	2	TDI		M5	TDI	5	TDI		M5	TDI	5	TDI	
N6	PB4E	2		T	N6	PB5C	5			N6	PB6C	5		
P6	VCC	-			P6	VCC	-			P6	VCC	-		
M6	PB4F	2		C	M6	PB6A	5			M6	PB8A	5		
P7	VCCAUX	-			P7	VCCAUX	-			P7	VCCAUX	-		
N7	PB5A	2		T	N7	PB6F	5			N7	PB8F	5		
M7	PB5B	2	PCLK2_1***	C	M7	PB7B	4	PCLK4_1***		M7	PB10F	4	PCLK4_1***	
N8	PB5D	2			N8	PB7C	4		T	N8	PB10C	4		T
P8	PB6A	2		T	P8	PB7D	4		C	P8	PB10D	4		C
M8	PB6B	2	PCLK2_0***	C	M8	PB7F	4	PCLK4_0***		M8	PB10B	4	PCLK4_0***	
N9	PB7A	2		T	N9	PB9A	4		T	N9	PB12A	4		T

## LCMXO640, LCMXO1200 and LCMXO2280 Logic Signal Connections: 256 caBGA / 256 ftBGA (Cont.)

LCMXO640					LCMXO1200					LCMXO2280				
Ball Number	Ball Function	Bank	Dual Function	Differential	Ball Number	Ball Function	Bank	Dual Function	Differential	Ball Number	Ball Function	Bank	Dual Function	Differential
J4	PL8A	3		T	J4	PL13A	6		T*	J4	PL16A	6		T*
J5	PL8B	3		C	J5	PL13B	6		C*	J5	PL16B	6		C*
R1	PL11A	3		T	R1	PL13C	6		T	R1	PL16C	6		T
R2	PL11B	3		C	R2	PL13D	6		C	R2	PL16D	6		C
-	-	-			-	-	-			GND	GND	-		
K5	NC				K5	PL14A	6	LLM0_PLLT_FB_A	T*	K5	PL17A	6	LLM0_PLLT_FB_A	T*
K4	NC				K4	PL14B	6	LLM0_PLLC_FB_A	C*	K4	PL17B	6	LLM0_PLLC_FB_A	C*
L5	PL10C	3		T	L5	PL14C	6		T	L5	PL17C	6		T
L4	PL10D	3		C	L4	PL14D	6		C	L4	PL17D	6		C
M5	NC				M5	PL15A	6	LLM0_PLLT_IN_A	T*	M5	PL18A	6	LLM0_PLLT_IN_A	T*
M4	NC				M4	PL15B	6	LLM0_PLLC_IN_A	C*	M4	PL18B	6	LLM0_PLLC_IN_A	C*
N4	PL11C	3		T	N4	PL16A	6		T	N4	PL19A	6		T
N3	PL11D	3		C	N3	PL16B	6		C	N3	PL19B	6		C
VCCIO3	VCCIO3	3			VCCIO6	VCCIO6	6			VCCIO6	VCCIO6	6		
GND	GNDIO3	3			GND	GNDIO6	6			GND	GNDIO6	6		
GND	GNDIO2	2			GND	GNDIO5	5			GND	GNDIO5	5		
VCCIO2	VCCIO2	2			VCCIO5	VCCIO5	5			VCCIO5	VCCIO5	5		
P4	TMS	2	TMS		P4	TMS	5	TMS		P4	TMS	5	TMS	
P2	NC				P2	PB2A	5		T	P2	PB2A	5		T
P3	NC				P3	PB2B	5		C	P3	PB2B	5		C
N5	NC				N5	PB2C	5		T	N5	PB2C	5		T
R3	TCK	2	TCK		R3	TCK	5	TCK		R3	TCK	5	TCK	
N6	NC				N6	PB2D	5		C	N6	PB2D	5		C
T2	PB2A	2		T	T2	PB3A	5		T	T2	PB3A	5		T
T3	PB2B	2		C	T3	PB3B	5		C	T3	PB3B	5		C
R4	PB2C	2		T	R4	PB3C	5		T	R4	PB3C	5		T
R5	PB2D	2		C	R5	PB3D	5		C	R5	PB3D	5		C
P5	PB3A	2		T	P5	PB4A	5		T	P5	PB4A	5		T
P6	PB3B	2		C	P6	PB4B	5		C	P6	PB4B	5		C
T5	PB3C	2		T	T5	PB4C	5		T	T5	PB4C	5		T
M6	TDO	2	TDO		M6	TDO	5	TDO		M6	TDO	5	TDO	
T4	PB3D	2		C	T4	PB4D	5		C	T4	PB4D	5		C
R6	PB4A	2		T	R6	PB5A	5		T	R6	PB5A	5		T
GND	GNDIO2	2			GND	GNDIO5	5			GND	GNDIO5	5		
VCCIO2	VCCIO2	2			VCCIO5	VCCIO5	5			VCCIO5	VCCIO5	5		
T6	PB4B	2		C	T6	PB5B	5		C	T6	PB5B	5		C
N7	TDI	2	TDI		N7	TDI	5	TDI		N7	TDI	5	TDI	
T8	PB4C	2		T	T8	PB5C	5		T	T8	PB6A	5		T
T7	PB4D	2		C	T7	PB5D	5		C	T7	PB6B	5		C
M7	NC				M7	PB6A	5		T	M7	PB7C	5		T
M8	NC				M8	PB6B	5		C	M8	PB7D	5		C
T9	VCCAUX	-			T9	VCCAUX	-			T9	VCCAUX	-		
R7	PB4E	2		T	R7	PB6C	5		T	R7	PB8C	5		T
R8	PB4F	2		C	R8	PB6D	5		C	R8	PB8D	5		C
-	-				VCCIO5	VCCIO5	5			VCCIO5	VCCIO5	5		
-	-				GND	GNDIO5	5			GND	GNDIO5	5		
P7	PB5C	2		T	P7	PB6E	5		T	P7	PB9A	4		T
P8	PB5D	2		C	P8	PB6F	5		C	P8	PB9B	4		C
N8	PB5A	2		T	N8	PB7A	4		T	N8	PB10E	4		T
N9	PB5B	2	PCLK2_1***	C	N9	PB7B	4	PCLK4_1***	C	N9	PB10F	4	PCLK4_1***	C
P10	PB7B	2		C	P10	PB7D	4		C	P10	PB10D	4		C
P9	PB7A	2		T	P9	PB7C	4		T	P9	PB10C	4		T
M9	PB6B	2	PCLK2_0***	C	M9	PB7F	4	PCLK4_0***	C	M9	PB10B	4	PCLK4_0***	C

## LCMXO640, LCMXO1200 and LCMXO2280 Logic Signal Connections: 256 caBGA / 256 ftBGA (Cont.)

LCMXO640					LCMXO1200					LCMXO2280				
Ball Number	Ball Function	Bank	Dual Function	Differential	Ball Number	Ball Function	Bank	Dual Function	Differential	Ball Number	Ball Function	Bank	Dual Function	Differential
D3	NC				D3	PT2C	0		T	D3	PT3C	0		T
A3	PT2B	0		C	A3	PT3B	0		C	A3	PT3B	0		C
A2	PT2A	0		T	A2	PT3A	0		T	A2	PT3A	0		T
B3	NC				B3	PT2B	0		C	B3	PT2D	0		C
B2	NC				B2	PT2A	0		T	B2	PT2C	0		T
VCCIO0	VCCIO0	0			VCCIO0	VCCIO0	0			VCCIO0	VCCIO0	0		
GND	GNDIO0	0			GND	GNDIO0	0			GND	GNDIO0	0		
A1	GND	-			A1	GND	-			A1	GND	-		
A16	GND	-			A16	GND	-			A16	GND	-		
F11	GND	-			F11	GND	-			F11	GND	-		
G8	GND	-			G8	GND	-			G8	GND	-		
G9	GND	-			G9	GND	-			G9	GND	-		
H7	GND	-			H7	GND	-			H7	GND	-		
H8	GND	-			H8	GND	-			H8	GND	-		
H9	GND	-			H9	GND	-			H9	GND	-		
H10	GND	-			H10	GND	-			H10	GND	-		
J7	GND	-			J7	GND	-			J7	GND	-		
J8	GND	-			J8	GND	-			J8	GND	-		
J9	GND	-			J9	GND	-			J9	GND	-		
J10	GND	-			J10	GND	-			J10	GND	-		
K8	GND	-			K8	GND	-			K8	GND	-		
K9	GND	-			K9	GND	-			K9	GND	-		
L6	GND	-			L6	GND	-			L6	GND	-		
T1	GND	-			T1	GND	-			T1	GND	-		
T16	GND	-			T16	GND	-			T16	GND	-		
G7	VCC	-			G7	VCC	-			G7	VCC	-		
G10	VCC	-			G10	VCC	-			G10	VCC	-		
K7	VCC	-			K7	VCC	-			K7	VCC	-		
K10	VCC	-			K10	VCC	-			K10	VCC	-		
H6	VCCIO3	3			H6	VCCIO7	7			H6	VCCIO7	7		
G6	VCCIO3	3			G6	VCCIO7	7			G6	VCCIO7	7		
K6	VCCIO3	3			K6	VCCIO6	6			K6	VCCIO6	6		
J6	VCCIO3	3			J6	VCCIO6	6			J6	VCCIO6	6		
L8	VCCIO2	2			L8	VCCIO5	5			L8	VCCIO5	5		
L7	VCCIO2	2			L7	VCCIO5	5			L7	VCCIO5	5		
L9	VCCIO2	2			L9	VCCIO4	4			L9	VCCIO4	4		
L10	VCCIO2	2			L10	VCCIO4	4			L10	VCCIO4	4		
K11	VCCIO1	1			K11	VCCIO3	3			K11	VCCIO3	3		
J11	VCCIO1	1			J11	VCCIO3	3			J11	VCCIO3	3		
H11	VCCIO1	1			H11	VCCIO2	2			H11	VCCIO2	2		
G11	VCCIO1	1			G11	VCCIO2	2			G11	VCCIO2	2		
F9	VCCIO0	0			F9	VCCIO1	1			F9	VCCIO1	1		
F10	VCCIO0	0			F10	VCCIO1	1			F10	VCCIO1	1		
F8	VCCIO0	0			F8	VCCIO0	0			F8	VCCIO0	0		
F7	VCCIO0	0			F7	VCCIO0	0			F7	VCCIO0	0		

\* Supports true LVDS outputs.  
 \*\* NC for "E" devices.  
 \*\*\* Primary clock inputs are single-ended.

### LCMXO2280 Logic Signal Connections: 324 ftBGA (Cont.)

LCMXO2280				
Ball Number	Ball Function	Bank	Dual Function	Differential
T2	PL20B	6		C
P6	TMS	5	TMS	
V1	PB2A	5		T
U2	PB2B	5		C
T3	PB2C	5		T
N7	TCK	5	TCK	
R4	PB2D	5		C
R5	PB3A	5		T
T4	PB3B	5		C
VCC	VCC	-		
R6	PB3C	5		T
P7	PB3D	5		C
U3	PB4A	5		T
T5	PB4B	5		C
V2	PB4C	5		T
N8	TDO	5	TDO	
V3	PB4D	5		C
T6	PB5A	5		T
GND	GNDIO5	5		
VCCIO5	VCCIO5	5		
U4	PB5B	5		C
P8	PB5C	5		T
T7	PB5D	5		C
V4	TDI	5	TDI	
R8	PB6A	5		T
N9	PB6B	5		C
U5	PB6C	5		T
V5	PB6D	5		C
U6	PB7A	5		T
VCC	VCC	-		
V6	PB7B	5		C
P9	PB7C	5		T
T8	PB7D	5		C
U7	PB8A	5		T
V7	PB8B	5		C
M10	VCCAUX	-		
U8	PB8C	5		T
V8	PB8D	5		C
VCCIO5	VCCIO5	5		
GND	GNDIO5	5		
T9	PB8E	5		T
U9	PB8F	5		C
V9	PB9A	4		T



**LCMXO2280 Logic Signal Connections: 324 ftBGA (Cont.)**

LCMXO2280				
Ball Number	Ball Function	Bank	Dual Function	Differential
V10	PB9B	4		C
N10	PB9C	4		T
R10	PB9D	4		C
P10	PB10F	4	PCLK4_1***	C
T10	PB10E	4		T
U10	PB10D	4		C
V11	PB10C	4		T
U11	PB10B	4	PCLK4_0***	C
VCCIO4	VCCIO4	4		
GND	GNDIO4	4		
T11	PB10A	4		T
U12	PB11A	4		T
R11	PB11B	4		C
GND	GND	-		
T12	PB11C	4		T
P11	PB11D	4		C
V12	PB12A	4		T
V13	PB12B	4		C
R12	PB12C	4		T
N11	PB12D	4		C
U13	PB12E	4		T
VCCIO4	VCCIO4	4		
GND	GNDIO4	4		
V14	PB12F	4		C
T13	PB13A	4		T
P12	PB13B	4		C
R13	PB13C	4		T
N12	PB13D	4		C
V15	PB14A	4		T
U14	PB14B	4		C
V16	PB14C	4		T
GND	GND	-		
T14	PB14D	4		C
U15	PB15A	4		T
V17	PB15B	4		C
P13**	SLEEPN	-	SLEEPN	
T15	PB15D	4		
U16	PB16A	4		T
V18	PB16B	4		C
N13	PB16C	4		T
R14	PB16D	4		C
VCCIO4	VCCIO4	4		
GND	GNDIO4	4		

## Thermal Management

Thermal management is recommended as part of any sound FPGA design methodology. To assess the thermal characteristics of a system, Lattice specifies a maximum allowable junction temperature in all device data sheets. Designers must complete a thermal analysis of their specific design to ensure that the device and package do not exceed the junction temperature limits. Refer to the [Thermal Management](#) document to find the device/package specific thermal values.

### For Further Information

For further information regarding Thermal Management, refer to the following:

- [Thermal Management](#) document
- TN1090 - [Power Estimation and Management for MachXO Devices](#)
- Power Calculator tool included with the Lattice ispLEVER design tool, or as a standalone download from [www.latticesemi.com/software](http://www.latticesemi.com/software)

Part Number	LUTs	Supply Voltage	I/Os	Grade	Package	Pins	Temp.
LCMXO256E-3T100I	256	1.2V	78	-3	TQFP	100	IND
LCMXO256E-4T100I	256	1.2V	78	-4	TQFP	100	IND
LCMXO256E-3M100I	256	1.2V	78	-3	csBGA	100	IND
LCMXO256E-4M100I	256	1.2V	78	-4	csBGA	100	IND

Part Number	LUTs	Supply Voltage	I/Os	Grade	Package	Pins	Temp.
LCMXO640E-3T100I	640	1.2V	74	-3	TQFP	100	IND
LCMXO640E-4T100I	640	1.2V	74	-4	TQFP	100	IND
LCMXO640E-3M100I	640	1.2V	74	-3	csBGA	100	IND
LCMXO640E-4M100I	640	1.2V	74	-4	csBGA	100	IND
LCMXO640E-3T144I	640	1.2V	113	-3	TQFP	144	IND
LCMXO640E-4T144I	640	1.2V	113	-4	TQFP	144	IND
LCMXO640E-3M132I	640	1.2V	101	-3	csBGA	132	IND
LCMXO640E-4M132I	640	1.2V	101	-4	csBGA	132	IND
LCMXO640E-3B256I	640	1.2V	159	-3	caBGA	256	IND
LCMXO640E-4B256I	640	1.2V	159	-4	caBGA	256	IND
LCMXO640E-3FT256I	640	1.2V	159	-3	ftBGA	256	IND
LCMXO640E-4FT256I	640	1.2V	159	-4	ftBGA	256	IND

Part Number	LUTs	Supply Voltage	I/Os	Grade	Package	Pins	Temp.
LCMXO1200E-3T100I	1200	1.2V	73	-3	TQFP	100	IND
LCMXO1200E-4T100I	1200	1.2V	73	-4	TQFP	100	IND
LCMXO1200E-3T144I	1200	1.2V	113	-3	TQFP	144	IND
LCMXO1200E-4T144I	1200	1.2V	113	-4	TQFP	144	IND
LCMXO1200E-3M132I	1200	1.2V	101	-3	csBGA	132	IND
LCMXO1200E-4M132I	1200	1.2V	101	-4	csBGA	132	IND
LCMXO1200E-3B256I	1200	1.2V	211	-3	caBGA	256	IND
LCMXO1200E-4B256I	1200	1.2V	211	-4	caBGA	256	IND
LCMXO1200E-3FT256I	1200	1.2V	211	-3	ftBGA	256	IND
LCMXO1200E-4FT256I	1200	1.2V	211	-4	ftBGA	256	IND

Part Number	LUTs	Supply Voltage	I/Os	Grade	Package	Pins	Temp.
LCMXO2280E-3T100I	2280	1.2V	73	-3	TQFP	100	IND
LCMXO2280E-4T100I	2280	1.2V	73	-4	TQFP	100	IND
LCMXO2280E-3T144I	2280	1.2V	113	-3	TQFP	144	IND
LCMXO2280E-4T144I	2280	1.2V	113	-4	TQFP	144	IND
LCMXO2280E-3M132I	2280	1.2V	101	-3	csBGA	132	IND
LCMXO2280E-4M132I	2280	1.2V	101	-4	csBGA	132	IND
LCMXO2280E-3B256I	2280	1.2V	211	-3	caBGA	256	IND
LCMXO2280E-4B256I	2280	1.2V	211	-4	caBGA	256	IND
LCMXO2280E-3FT256I	2280	1.2V	211	-3	ftBGA	256	IND
LCMXO2280E-4FT256I	2280	1.2V	211	-4	ftBGA	256	IND
LCMXO2280E-3FT324I	2280	1.2V	271	-3	ftBGA	324	IND
LCMXO2280E-4FT324I	2280	1.2V	271	-4	ftBGA	324	IND

Date	Version	Section	Change Summary
April 2006 (cont.)	02.0 (cont.)	Architecture (cont.)	"Top View of the MachXO1200 Device" figure updated.
			"Top View of the MachXO640 Device" figure updated.
			"Top View of the MachXO256 Device" figure updated.
			"Slice Diagram" figure updated.
			Slice Signal Descriptions table updated.
			Routing section updated.
			sysCLOCK Phase Locked Loops (PLLs) section updated.
			PLL Diagram updated.
			PLL Signal Descriptions table updated.
			sysMEM Memory section has been updated.
			PIO Groups section has been updated.
			PIO section has been updated.
			MachXO PIO Block Diagram updated.
			Supported Input Standards table updated.
		MachXO Configuration and Programming diagram updated.	
		DC and Switching Characteristics	Recommended Operating Conditions table - footnotes updated.
			MachXO256 and MachXO640 Hot Socketing Specifications - footnotes updated.
			Added MachXO1200 and MachXO2280 Hot Socketing Specifications table.
			DC Electrical Characteristics, footnotes have been updated.
			Supply Current (Sleep Mode) table has been updated, removed "4W" references. Footnotes have been updated.
			Supply Current (Standby) table and associated footnotes updated.
			Initialization Supply Current table and footnotes updated.
			Programming and Erase Flash Supply Current table and associated footnotes have been updated.
			Register-to-Register Performance table updated (rev. A 0.19).
			MachXO External Switching Characteristics updated (rev. A 0.19).
			MachXO Internal Timing Parameters updated (rev. A 0.19).
			MachXO Family Timing Adders updated (rev. A 0.19).
			sysCLOCK Timing updated (rev. A 0.19).
			MachXO "C" Sleep Mode Timing updated (A 0.19).
		JTAG Port Timing Specification updated (rev. A 0.19).	
		Test Fixture Required Components table updated.	
		Pinout Information	Signal Descriptions have been updated.
			Pin Information Summary has been updated. Footnote has been added.
Power Supply and NC Connection table has been updated.			
Logic Signal Connections have been updated (PCLKTx_x --> PCLKx_x)			
Ordering Information	Removed "4W" references.		
	Added 256-ftBGA Ordering Part Numbers for MachXO640.		
May 2006	02.1	Pinout Information	Removed [LOC][0]_PLL_RST from Signal Description table.
			PCLK footnote has been added to all appropriate pins.
August 2006	02.2	Multiple	Removed 256 fpBGA information for MachXO640.

Date	Version	Section	Change Summary
November 2006	02.3	DC and Switching Characteristics	Corrections to MachXO “C” Sleep Mode Timing table - value for $t_{WSLEEPN}$ (400ns) changed from max. to min. Value for $t_{WAWAKE}$ (100ns) changed from min. to max. Added Flash Download Time table.
		Architecture	EBR Asynchronous Reset section added.
December 2006	02.4	Pinout Information	Power Supply and NC table: Pin/Ball orientation footnotes added.
February 2007	02.5	Architecture	Updated EBR Asynchronous Reset section.
August 2007	02.6	DC and Switching Characteristics	Updated sysIO Single-Ended DC Electrical Characteristics table.
November 2007	02.7	DC and Switching Characteristics	Added JTAG Port Timing Waveforms diagram.
		Pinout Information	Added Thermal Management text section.
		Supplemental Information	Updated title list.
June 2009	02.8	Introduction	Added 0.8-mm 256-pin caBGA package to MachXO Family Selection Guide table.
		Pinout Information	Added Logic Signal Connections table for 0.8-mm 256-pin caBGA package.
		Ordering Information	Updated Part Number Description diagram and Ordering Part Number tables with 0.8-mm 256-pin caBGA package information.
July 2010	02.9	DC and Switching Characteristics	Updated sysCLOCK PLL Timing table.
June 2013	03.0	All	Updated document with new corporate logo.
		Architecture	Architecture Overview – Added information on the state of the register on power up and after configuration.
		DC and Switching Characteristics	MachXO1200 and MachXO2280 Hot Socketing Specifications table – Removed footnote 4. Added MachXO Programming/Erase Specifications table.