

Welcome to E-XFL.COM

Understanding [Embedded - FPGAs \(Field Programmable Gate Array\)](#)

Embedded - FPGAs, or Field Programmable Gate Arrays, are advanced integrated circuits that offer unparalleled flexibility and performance for digital systems. Unlike traditional fixed-function logic devices, FPGAs can be programmed and reprogrammed to execute a wide array of logical operations, enabling customized functionality tailored to specific applications. This reprogrammability allows developers to iterate designs quickly and implement complex functions without the need for custom hardware.

Applications of Embedded - FPGAs

The versatility of Embedded - FPGAs makes them indispensable in numerous fields. In telecommunications,

Details

Product Status	Obsolete
Number of LABs/CLBs	32
Number of Logic Elements/Cells	256
Total RAM Bits	-
Number of I/O	78
Number of Gates	-
Voltage - Supply	1.14V ~ 1.26V
Mounting Type	Surface Mount
Operating Temperature	-40°C ~ 100°C (TJ)
Package / Case	100-LFBGA, CSPBGA
Supplier Device Package	100-CSBGA (8x8)
Purchase URL	https://www.e-xfl.com/product-detail/lattice-semiconductor/lcmx0256e-3m100i

Architecture Overview

The MachXO family architecture contains an array of logic blocks surrounded by Programmable I/O (PIO). Some devices in this family have sysCLOCK PLLs and blocks of sysMEM™ Embedded Block RAM (EBRs). Figures 2-1, 2-2, and 2-3 show the block diagrams of the various family members.

The logic blocks are arranged in a two-dimensional grid with rows and columns. The EBR blocks are arranged in a column to the left of the logic array. The PIO cells are located at the periphery of the device, arranged into Banks. The PIOs utilize a flexible I/O buffer referred to as a sysIO interface that supports operation with a variety of interface standards. The blocks are connected with many vertical and horizontal routing channel resources. The place and route software tool automatically allocates these routing resources.

There are two kinds of logic blocks, the Programmable Functional Unit (PFU) and the Programmable Functional unit without RAM (PFF). The PFU contains the building blocks for logic, arithmetic, RAM, ROM, and register functions. The PFF block contains building blocks for logic, arithmetic, ROM, and register functions. Both the PFU and PFF blocks are optimized for flexibility, allowing complex designs to be implemented quickly and effectively. Logic blocks are arranged in a two-dimensional array. Only one type of block is used per row.

In the MachXO family, the number of sysIO Banks varies by device. There are different types of I/O Buffers on different Banks. See the details in later sections of this document. The sysMEM EBRs are large, dedicated fast memory blocks; these blocks are found only in the larger devices. These blocks can be configured as RAM, ROM or FIFO. FIFO support includes dedicated FIFO pointer and flag “hard” control logic to minimize LUT use.

The MachXO registers in PFU and sysI/O can be configured to be SET or RESET. After power up and device is configured, the device enters into user mode with these registers SET/RESET according to the configuration setting, allowing device entering to a known state for predictable system function.

The MachXO architecture provides up to two sysCLOCK™ Phase Locked Loop (PLL) blocks on larger devices. These blocks are located at either end of the memory blocks. The PLLs have multiply, divide, and phase shifting capabilities that are used to manage the frequency and phase relationships of the clocks.

Every device in the family has a JTAG Port that supports programming and configuration of the device as well as access to the user logic. The MachXO devices are available for operation from 3.3V, 2.5V, 1.8V, and 1.2V power supplies, providing easy integration into the overall system.

Figure 2-1. Top View of the MachXO1200 Device¹

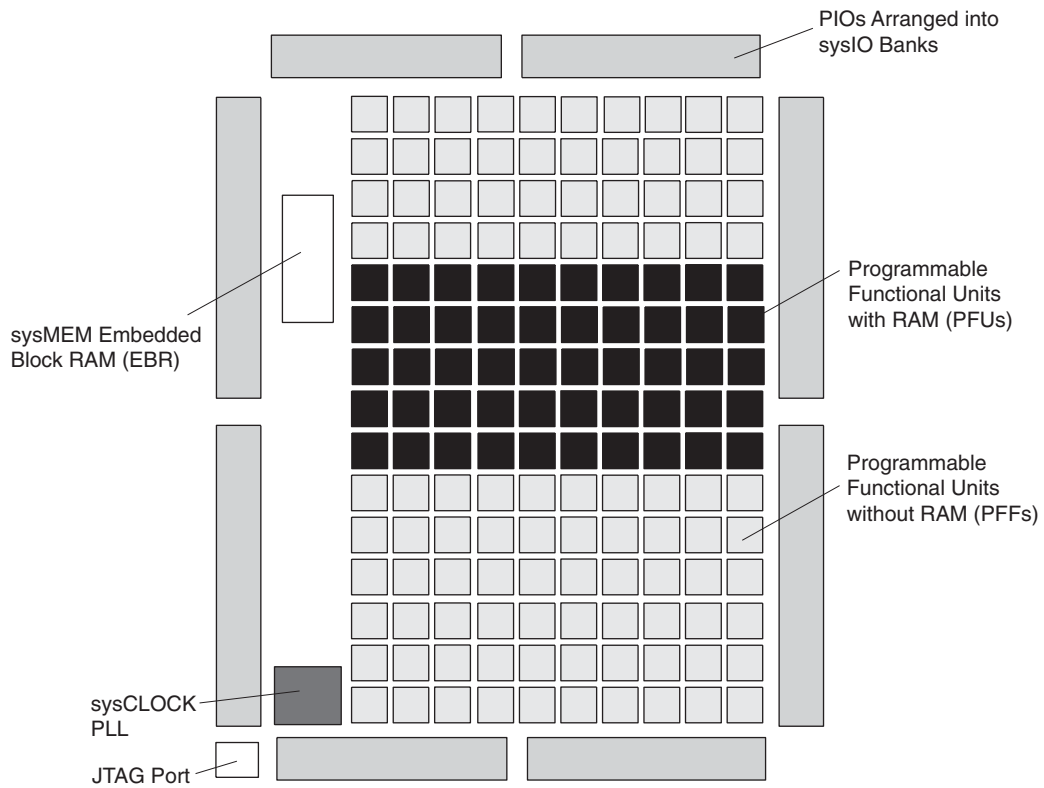

1. Top view of the MachXO2280 device is similar but with higher LUT count, two PLLs, and three EBR blocks.

Figure 2-2. Top View of the MachXO640 Device

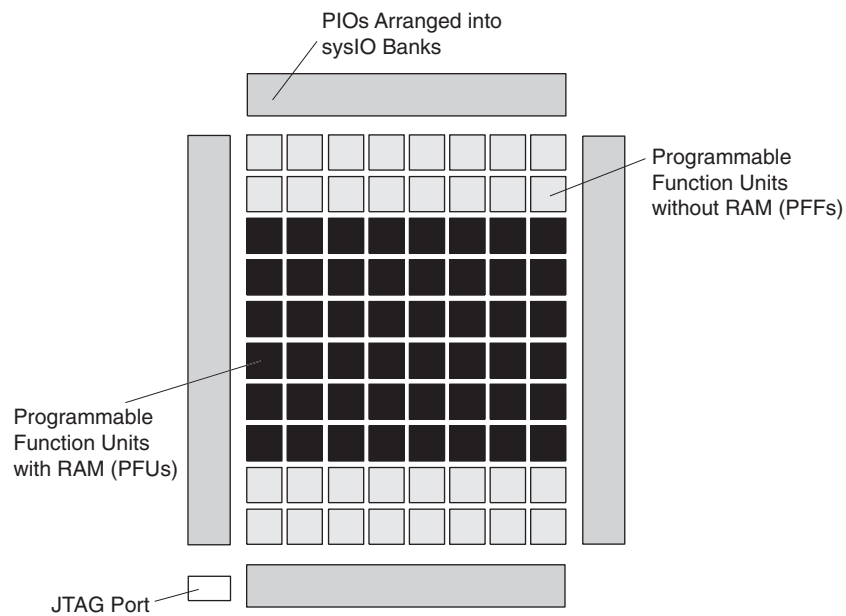

Table 2-5. PLL Signal Descriptions

Signal	I/O	Description
CLKI	I	Clock input from external pin or routing
CLKFB	I	PLL feedback input from PLL output, clock net, routing/external pin or internal feedback from CLKINTFB port
RST	I	“1” to reset the input clock divider
CLKOS	O	PLL output clock to clock tree (phase shifted/duty cycle changed)
CLKOP	O	PLL output clock to clock tree (No phase shift)
CLKOK	O	PLL output to clock tree through secondary clock divider
LOCK	O	“1” indicates PLL LOCK to CLKI
CLKINTFB	O	Internal feedback source, CLKOP divider output before CLOKRTREE
DDAMODE	I	Dynamic Delay Enable. “1”: Pin control (dynamic), “0”: Fuse Control (static)
DDAIZR	I	Dynamic Delay Zero. “1”: delay = 0, “0”: delay = on
DDAILAG	I	Dynamic Delay Lag/Lead. “1”: Lag, “0”: Lead
DDAIDEL[2:0]	I	Dynamic Delay Input

For more information on the PLL, please see details of additional technical documentation at the end of this data sheet.

sysMEM Memory

The MachXO1200 and MachXO2280 devices contain sysMEM Embedded Block RAMs (EBRs). The EBR consists of a 9-Kbit RAM, with dedicated input and output registers.

sysMEM Memory Block

The sysMEM block can implement single port, dual port, pseudo dual port, or FIFO memories. Each block can be used in a variety of depths and widths as shown in Table 2-6.

Table 2-6. sysMEM Block Configurations

Memory Mode	Configurations
Single Port	8,192 x 1
	4,096 x 2
	2,048 x 4
	1,024 x 9
	512 x 18
	256 x 36
True Dual Port	8,192 x 1
	4,096 x 2
	2,048 x 4
	1,024 x 9
	512 x 18
Pseudo Dual Port	8,192 x 1
	4,096 x 2
	2,048 x 4
	1,024 x 9
	512 x 18
	256 x 36
FIFO	8,192 x 1
	4,096 x 2
	2,048 x 4
	1,024 x 9
	512 x 18
	256 x 36

of the devices also support differential input buffers. PCI clamps are available on the top Bank I/O buffers. The PCI clamp is enabled after V_{CC} , V_{CCAUX} , and V_{CCIO} are at valid operating levels and the device has been configured.

The two pads in the pair are described as “true” and “comp”, where the true pad is associated with the positive side of the differential input buffer and the comp (complementary) pad is associated with the negative side of the differential input buffer.

2. Left and Right sysIO Buffer Pairs

The sysIO buffer pairs in the left and right Banks of the device consist of two single-ended output drivers and two sets of single-ended input buffers (supporting ratioed and absolute input levels). The devices also have a differential driver per output pair. The referenced input buffer can also be configured as a differential input buffer. In these Banks the two pads in the pair are described as “true” and “comp”, where the true pad is associated with the positive side of the differential I/O, and the comp (complementary) pad is associated with the negative side of the differential I/O.

Typical I/O Behavior During Power-up

The internal power-on-reset (POR) signal is deactivated when V_{CC} and V_{CCAUX} have reached satisfactory levels. After the POR signal is deactivated, the FPGA core logic becomes active. It is the user's responsibility to ensure that all V_{CCIO} Banks are active with valid input logic levels to properly control the output logic states of all the I/O Banks that are critical to the application. The default configuration of the I/O pins in a blank device is tri-state with a weak pull-up to V_{CCIO} . The I/O pins will maintain the blank configuration until V_{CC} , V_{CCAUX} and V_{CCIO} have reached satisfactory levels at which time the I/Os will take on the user-configured settings.

The V_{CC} and V_{CCAUX} supply the power to the FPGA core fabric, whereas the V_{CCIO} supplies power to the I/O buffers. In order to simplify system design while providing consistent and predictable I/O behavior, the I/O buffers should be powered up along with the FPGA core fabric. Therefore, V_{CCIO} supplies should be powered up before or together with the V_{CC} and V_{CCAUX} supplies

Supported Standards

The MachXO sysIO buffer supports both single-ended and differential standards. Single-ended standards can be further subdivided into LVCMOS and LVTTTL. The buffer supports the LVTTTL, LVCMOS 1.2, 1.5, 1.8, 2.5, and 3.3V standards. In the LVCMOS and LVTTTL modes, the buffer has individually configurable options for drive strength, bus maintenance (weak pull-up, weak pull-down, bus-keeper latch or none) and open drain. BLVDS and LVPECL output emulation is supported on all devices. The MachXO1200 and MachXO2280 support on-chip LVDS output buffers on approximately 50% of the I/Os on the left and right Banks. Differential receivers for LVDS, BLVDS and LVPECL are supported on all Banks of MachXO1200 and MachXO2280 devices. PCI support is provided in the top Banks of the MachXO1200 and MachXO2280 devices. Table 2-8 summarizes the I/O characteristics of the devices in the MachXO family.

Tables 2-9 and 2-10 show the I/O standards (together with their supply and reference voltages) supported by the MachXO devices. For further information on utilizing the sysIO buffer to support a variety of standards please see the details of additional technical documentation at the end of this data sheet.

Figure 2-18. MachXO2280 Banks



Figure 2-19. MachXO1200 Banks



Figure 2-20. MachXO640 Banks



Figure 2-21. MachXO256 Banks

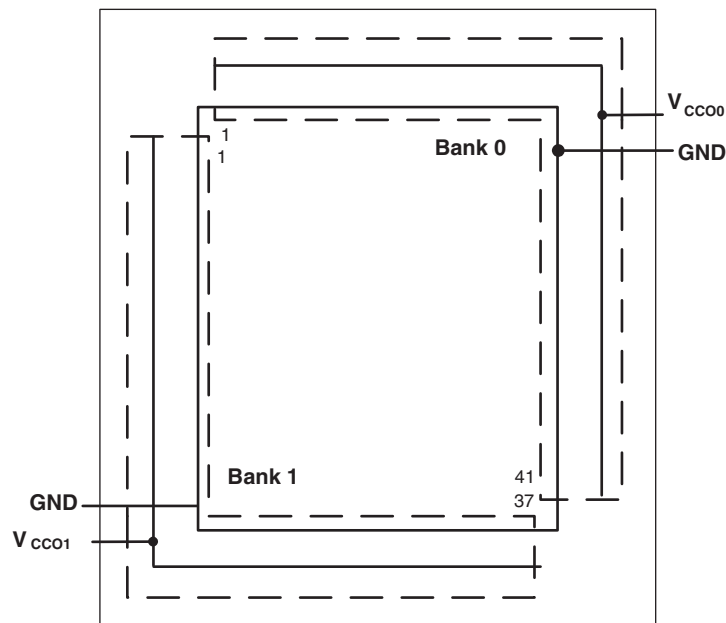

Hot Socketing

The MachXO devices have been carefully designed to ensure predictable behavior during power-up and power-down. Leakage into I/O pins is controlled to within specified limits. This allows for easy integration with the rest of

Figure 2-22. MachXO Configuration and Programming

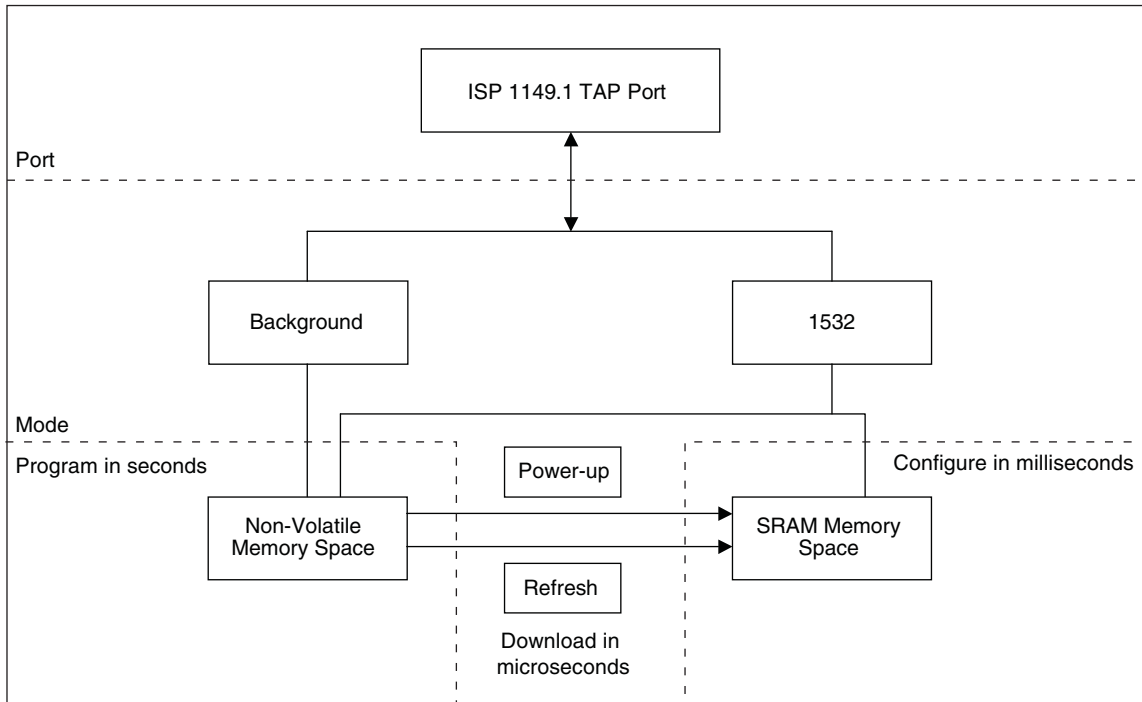

Density Shifting

The MachXO family has been designed to enable density migration in the same package. Furthermore, the architecture ensures a high success rate when performing design migration from lower density parts to higher density parts. In many cases, it is also possible to shift a lower utilization design targeted for a high-density device to a lower density device. However, the exact details of the final resource utilization will impact the likely success in each case.

Table 3-1. LVDS DC Conditions

Over Recommended Operating Conditions

Parameter	Description	Typical	Units
Z _{OUT}	Output impedance	20	Ω
R _S	Driver series resistor	294	Ω
R _P	Driver parallel resistor	121	Ω
R _T	Receiver termination	100	Ω
V _{OH}	Output high voltage	1.43	V
V _{OL}	Output low voltage	1.07	V
V _{OD}	Output differential voltage	0.35	V
V _{CM}	Output common mode voltage	1.25	V
Z _{BACK}	Back impedance	100	Ω
I _{DC}	DC output current	3.66	mA

BLVDS

The MachXO family supports the BLVDS standard through emulation. The output is emulated using complementary LVCMOS outputs in conjunction with a parallel external resistor across the driver outputs. The input standard is supported by the LVDS differential input buffer on certain devices. BLVDS is intended for use when multi-drop and bi-directional multi-point differential signaling is required. The scheme shown in Figure 3-2 is one possible solution for bi-directional multi-point differential signals.

Figure 3-2. BLVDS Multi-point Output Example

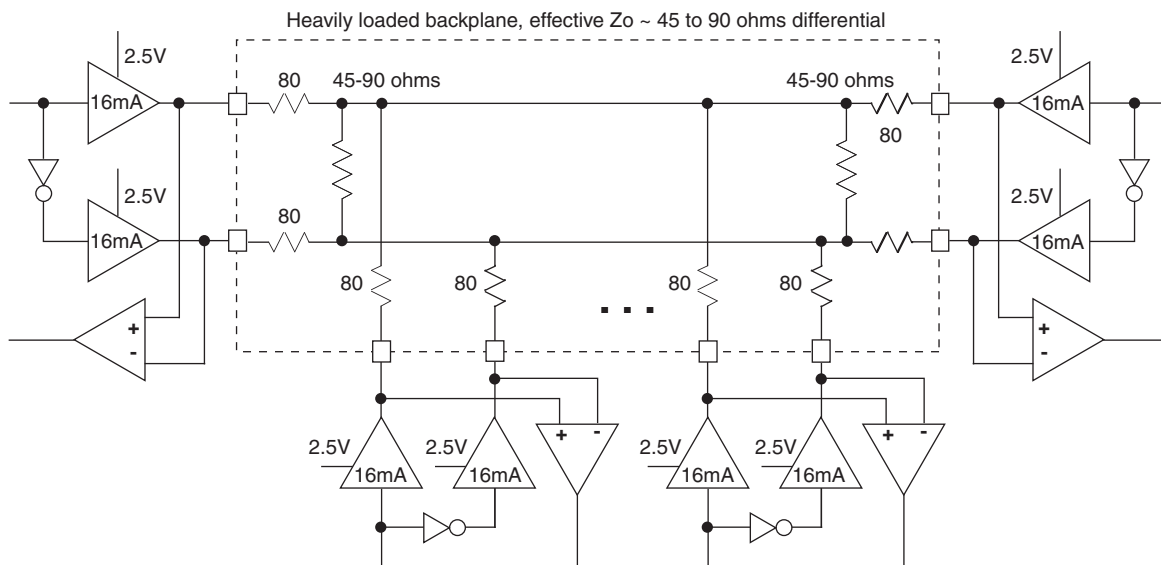

For further information on LVPECL, BLVDS and other differential interfaces please see details of additional technical documentation at the end of the data sheet.

RSDS

The MachXO family supports the differential RSDS standard. The output standard is emulated using complementary LVCMOS outputs in conjunction with a parallel resistor across the driver outputs on all the devices. The RSDS input standard is supported by the LVDS differential input buffer on certain devices. The scheme shown in Figure 3-4 is one possible solution for RSDS standard implementation. Use LVDS25E mode with suggested resistors for RSDS operation. Resistor values in Figure 3-4 are industry standard values for 1% resistors.

Figure 3-4. RSDS (Reduced Swing Differential Standard)

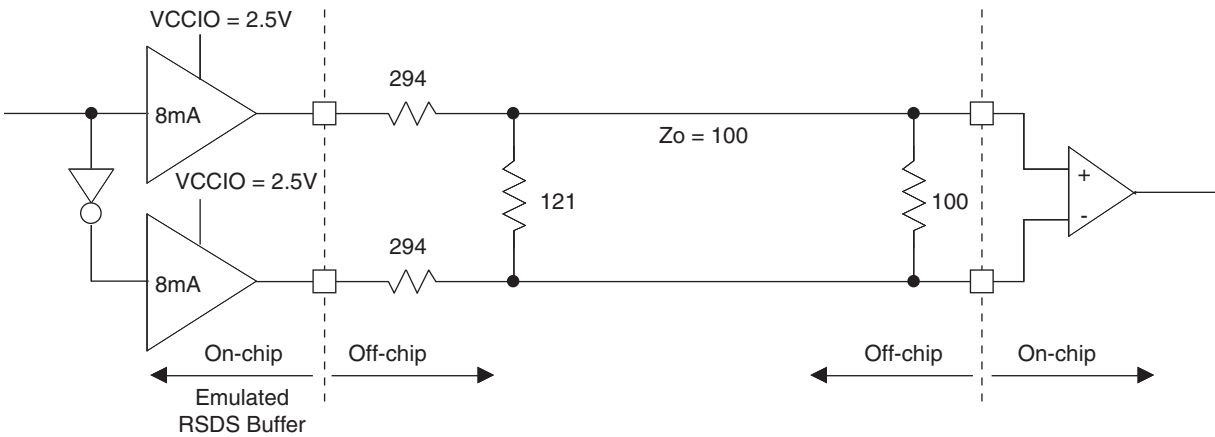

Table 3-4. RSDS DC Conditions

Parameter	Description	Typical	Units
Z_{OUT}	Output impedance	20	Ohms
R_S	Driver series resistor	294	Ohms
R_P	Driver parallel resistor	121	Ohms
R_T	Receiver termination	100	Ohms
V_{OH}	Output high voltage	1.35	V
V_{OL}	Output low voltage	1.15	V
V_{OD}	Output differential voltage	0.20	V
V_{CM}	Output common mode voltage	1.25	V
Z_{BACK}	Back impedance	101.5	Ohms
I_{DC}	DC output current	3.66	mA

Signal Descriptions

Signal Name	I/O	Descriptions
General Purpose		
P[Edge] [Row/Column Number]_[A/B/C/D/E/F]	I/O	<p>[Edge] indicates the edge of the device on which the pad is located. Valid edge designations are L (Left), B (Bottom), R (Right), T (Top).</p> <p>[Row/Column Number] indicates the PFU row or the column of the device on which the PIO Group exists. When Edge is T (Top) or (Bottom), only need to specify Row Number. When Edge is L (Left) or R (Right), only need to specify Column Number.</p> <p>[A/B/C/D/E/F] indicates the PIO within the group to which the pad is connected.</p> <p>Some of these user programmable pins are shared with special function pins. When not used as special function pins, these pins can be programmed as I/Os for user logic.</p> <p>During configuration of the user-programmable I/Os, the user has an option to tri-state the I/Os and enable an internal pull-up resistor. This option also applies to unused pins (or those not bonded to a package pin). The default during configuration is for user-programmable I/Os to be tri-stated with an internal pull-up resistor enabled. When the device is erased, I/Os will be tri-stated with an internal pull-up resistor enabled.</p>
GSRN	I	Global RESET signal (active low). Dedicated pad, when not in use it can be used as an I/O pin.
TSALL	I	TSALL is a dedicated pad for the global output enable signal. When TSALL is high all the outputs are tristated. It is a dual function pin. When not in use, it can be used as an I/O pin.
NC	—	No connect.
GND	—	GND - Ground. Dedicated pins.
V _{CC}	—	VCC - The power supply pins for core logic. Dedicated pins.
V _{CCAUX}	—	VCCAUX - the Auxiliary power supply pin. This pin powers up a variety of internal circuits including all the differential and referenced input buffers. Dedicated pins.
V _{CCIOx}	—	VCCIO - The power supply pins for I/O Bank x. Dedicated pins.
SLEEPN ¹	I	Sleep Mode pin - Active low sleep pin. When this pin is held high, the device operates normally. This pin has a weak internal pull-up, but when unused, an external pull-up to V _{CC} is recommended. When driven low, the device moves into Sleep mode after a specified time.
PLL and Clock Functions (Used as user programmable I/O pins when not used for PLL or clock pins)		
[LOC][0]_PLL[T, C]_IN	—	Reference clock (PLL) input Pads: [LOC] indicates location. Valid designations are ULM (Upper PLL) and LLM (Lower PLL). T = true and C = complement.
[LOC][0]_PLL[T, C]_FB	—	Optional feedback (PLL) input Pads: [LOC] indicates location. Valid designations are ULM (Upper PLL) and LLM (Lower PLL). T = true and C = complement.
PCLK [n]_[1:0]	—	Primary Clock Pads, n per side.
Test and Programming (Dedicated pins)		
TMS	I	Test Mode Select input pin, used to control the 1149.1 state machine.
TCK	I	Test Clock input pin, used to clock the 1149.1 state machine.
TDI	I	Test Data input pin, used to load data into the device using an 1149.1 state machine.
TDO	O	Output pin -Test Data output pin used to shift data out of the device using 1149.1.

1. Applies to MachXO “C” devices only. NC for “E” devices.

LCMX0256 and LCMX0640 Logic Signal Connections: 100 csBGA

LCMX0256					LCMX0640				
Ball Number	Ball Function	Bank	Dual Function	Differential	Ball Number	Ball Function	Bank	Dual Function	Differential
B1	PL2A	1		T	B1	PL2A	3		T
C1	PL2B	1		C	C1	PL2C	3		T
D2	PL3A	1		T	D2	PL2B	3		C
D1	PL3B	1		C	D1	PL2D	3		C
C2	PL3C	1		T	C2	PL3A	3		T
E1	PL3D	1		C	E1	PL3B	3		C
E2	PL4A	1		T	E2	PL3C	3		T
F1	PL4B	1		C	F1	PL3D	3		C
F2	PL5A	1		T	F2	PL4A	3		
G2	PL5B	1		C	G2	PL4C	3		T
H1	GNDIO1	1			H1	GNDIO3	3		
H2	PL5C	1		T	H2	PL4D	3		C
J1	PL5D	1	GSRN	C	J1	PL5B	3	GSRN	
J2	PL6A	1		T	J2	PL7B	3		
K1	PL6B	1	TSALL	C	K1	PL8C	3	TSALL	T
K2	PL7A	1		T	K2	PL8D	3		C
L1	PL7B	1		C	L1	PL9A	3		
L2	PL7C	1		T	L2	PL9C	3		
M1	PL7D	1		C	M1	PL10A	3		
M2	PL8A	1		T	M2	PL10C	3		
N1	PL8B	1		C	N1	PL11A	3		
M3	PL9A	1		T	M3	PL11C	3		
N2	GNDIO1	1			N2	GNDIO3	3		
P2	TMS	1	TMS		P2	TMS	2	TMS	
P3	PL9B	1		C	P3	PB2C	2		
N4	TCK	1	TCK		N4	TCK	2	TCK	
P4	PB2A	1		T	P4	VCCIO2	2		
N3	PB2B	1		C	N3	GNDIO2	2		
P5	TDO	1	TDO		P5	TDO	2	TDO	
N5	PB2C	1		T	N5	PB4C	2		
P6	TDI	1	TDI		P6	TDI	2	TDI	
N6	PB2D	1		C	N6	PB4E	2		
P7	VCC	-			P7	VCC	-		
N7	PB3A	1	PCLK1_1**	T	N7	PB5B	2	PCLK2_1**	
P8	PB3B	1		C	P8	PB5D	2		
N8	PB3C	1	PCLK1_0**	T	N8	PB6B	2	PCLK2_0**	
P9	PB3D	1		C	P9	PB6C	2		
N10	GNDIO1	1			N10	GNDIO2	2		
P11	PB4A	1		T	P11	PB8B	2		
N11	PB4B	1		C	N11	PB8C	2		T
P12	PB4C	1		T	P12	PB8D	2		C
N12	PB4D	1		C	N12	PB9A	2		

LCMXO640, LCMXO1200 and LCMXO2280 Logic Signal Connections: 132 csBGA (Cont.)

LCMXO640					LCMXO1200					LCMXO2280				
Ball #	Ball Function	Bank	Dual Function	Differential	Ball #	Ball Function	Bank	Dual Function	Differential	Ball #	Ball Function	Bank	Dual Function	Differential
B9	PT7B	0		C	B9	PT9B	1		C	B9	PT12D	1		C
A9	PT7A	0		T	A9	PT9A	1		T	A9	PT12C	1		T
A8	PT6B	0	PCLK0_1***	C	A8	PT7D	1	PCLK1_1***		A8	PT10B	1	PCLK1_1***	
B8	PT6A	0		T	B8	PT7B	1			B8	PT9D	1		
C8	PT5B	0	PCLK0_0***	C	C8	PT6F	0	PCLK1_0***		C8	PT9B	1	PCLK1_0***	
B7	PT5A	0		T	B7	PT6D	0			B7	PT8D	0		
A7	VCCAUX	-			A7	VCCAUX	-			A7	VCCAUX	-		
C7	VCC	-			C7	VCC	-			C7	VCC	-		
A6	PT4D	0		C	A6	PT5D	0		C	A6	PT7B	0		C
B6	PT4C	0		T	B6	PT5C	0		T	B6	PT7A	0		T
C6	PT3F	0		C	C6	PT5B	0		C	C6	PT6D	0		
B5	PT3E	0		T	B5	PT5A	0		T	B5	PT6E	0		T
A5	PT3D	0			A5	PT4B	0			A5	PT6F	0		C
B4	GNDIO0	0			B4	GNDIO0	0			B4	GNDIO0	0		
A4	PT3B	0			A4	PT3D	0		C	A4	PT4B	0		C
C4	PT2F	0			C4	PT3C	0		T	C4	PT4A	0		T
A3	PT2D	0		C	A3	PT3B	0		C	A3	PT3B	0		C
A2	PT2C	0		T	A2	PT2B	0		C	A2	PT2B	0		C
B3	PT2B	0		C	B3	PT3A	0		T	B3	PT3A	0		T
A1	PT2A	0		T	A1	PT2A	0		T	A1	PT2A	0		T
F1	GND	-			F1	GND	-			F1	GND	-		
P9	GND	-			P9	GND	-			P9	GND	-		
J14	GND	-			J14	GND	-			J14	GND	-		
C9	GND	-			C9	GND	-			C9	GND	-		
C5	VCCIO0	0			C5	VCCIO0	0			C5	VCCIO0	0		
B11	VCCIO0	0			B11	VCCIO1	1			B11	VCCIO1	1		
E12	VCCIO1	1			E12	VCCIO2	2			E12	VCCIO2	2		
L12	VCCIO1	1			L12	VCCIO3	3			L12	VCCIO3	3		
M10	VCCIO2	2			M10	VCCIO4	4			M10	VCCIO4	4		
N2	VCCIO2	2			N2	VCCIO5	5			N2	VCCIO5	5		
D2	VCCIO3	3			D2	VCCIO7	7			D2	VCCIO7	7		
K3	VCCIO3	3			K3	VCCIO6	6			K3	VCCIO6	6		

*Supports true LVDS outputs.

**NC for "E" devices.

***Primary clock inputs are single-ended.

LCMXO2280 Logic Signal Connections: 324 ftBGA

LCMXO2280				
Ball Number	Ball Function	Bank	Dual Function	Differential
GND	GNDIO7	7		
VCCIO7	VCCIO7	7		
D4	PL2A	7	LUM0_PLLT_FB_A	T
F5	PL2B	7	LUM0_PLLC_FB_A	C
B3	PL3A	7		T*
C3	PL3B	7		C*
E4	PL3C	7	LUM0_PLLT_IN_A	T
G6	PL3D	7	LUM0_PLLC_IN_A	C
A1	PL4A	7		T*
B1	PL4B	7		C*
F4	PL4C	7		T
VCC	VCC	-		
E3	PL4D	7		C
D2	PL5A	7		T*
D3	PL5B	7		C*
G5	PL5C	7		T
F3	PL5D	7		C
C2	PL6A	7		T*
VCCIO7	VCCIO7	7		
GND	GNDIO7	7		
C1	PL6B	7		C*
H5	PL6C	7		T
G4	PL6D	7		C
E2	PL7A	7		T*
D1	PL7B	7	GSRN	C*
J6	PL7C	7		T
H4	PL7D	7		C
F2	PL8A	7		T*
E1	PL8B	7		C*
GND	GND	-		
J3	PL8C	7		T
J5	PL8D	7		C
G3	PL9A	7		T*
H3	PL9B	7		C*
K3	PL9C	7		T
K5	PL9D	7		C
F1	PL10A	7		T*
VCCIO7	VCCIO7	7		
GND	GNDIO7	7		
G1	PL10B	7		C*
K4	PL10C	7		T
K6	PL10D	7		C

LCMXO2280 Logic Signal Connections: 324 ftBGA (Cont.)

LCMXO2280				
Ball Number	Ball Function	Bank	Dual Function	Differential
GND	GNDIO3	3		
VCCIO3	VCCIO3	3		
P15	PR20B	3		C
N14	PR20A	3		T
N15	PR19B	3		C
M13	PR19A	3		T
R15	PR18B	3		C*
T16	PR18A	3		T*
N16	PR17D	3		C
M14	PR17C	3		T
U17	PR17B	3		C*
VCC	VCC	-		
U18	PR17A	3		T*
R17	PR16D	3		C
R16	PR16C	3		T
P16	PR16B	3		C*
VCCIO3	VCCIO3	3		
GND	GNDIO3	3		
P17	PR16A	3		T*
L13	PR15D	3		C
M15	PR15C	3		T
T17	PR15B	3		C*
T18	PR15A	3		T*
L14	PR14D	3		C
L15	PR14C	3		T
R18	PR14B	3		C*
P18	PR14A	3		T*
GND	GND	-		
K15	PR13D	3		C
K13	PR13C	3		T
N17	PR13B	3		C*
N18	PR13A	3		T*
K16	PR12D	3		C
K14	PR12C	3		T
M16	PR12B	3		C*
L16	PR12A	3		T*
GND	GNDIO3	3		
VCCIO3	VCCIO3	3		
J16	PR11D	3		C
J14	PR11C	3		T
M17	PR11B	3		C*
L17	PR11A	3		T*
J15	PR10D	2		C

LCMXO2280 Logic Signal Connections: 324 ftBGA (Cont.)

LCMXO2280				
Ball Number	Ball Function	Bank	Dual Function	Differential
J13	PR10C	2		T
M18	PR10B	2		C*
L18	PR10A	2		T*
GND	GNDIO2	2		
VCCIO2	VCCIO2	2		
H16	PR9D	2		C
H14	PR9C	2		T
K18	PR9B	2		C*
J18	PR9A	2		T*
J17	PR8D	2		C
VCC	VCC	-		
H18	PR8C	2		T
H17	PR8B	2		C*
G17	PR8A	2		T*
H13	PR7D	2		C
H15	PR7C	2		T
G18	PR7B	2		C*
F18	PR7A	2		T*
G14	PR6D	2		C
G16	PR6C	2		T
VCCIO2	VCCIO2	2		
GND	GNDIO2	2		
E18	PR6B	2		C*
F17	PR6A	2		T*
G13	PR5D	2		C
G15	PR5C	2		T
E17	PR5B	2		C*
E16	PR5A	2		T*
GND	GND	-		
F15	PR4D	2		C
E15	PR4C	2		T
D17	PR4B	2		C*
D18	PR4A	2		T*
B18	PR3D	2		C
C18	PR3C	2		T
C16	PR3B	2		C*
D16	PR3A	2		T*
C17	PR2B	2		C
D15	PR2A	2		T
VCCIO2	VCCIO2	2		
GND	GNDIO2	2		
GND	GNDIO1	1		
VCCIO1	VCCIO1	1		

LCMX02280 Logic Signal Connections: 324 ftBGA (Cont.)

LCMX02280				
Ball Number	Ball Function	Bank	Dual Function	Differential
G8	VCCIO0	0		
G7	VCCIO0	0		

* Supports true LVDS outputs.

** NC for "E" devices.

*** Primary clock inputs are single-ended.

Part Number	LUTs	Supply Voltage	I/Os	Grade	Package	Pins	Temp.
LCMXO2280C-3T100C	2280	1.8V/2.5V/3.3V	73	-3	TQFP	100	COM
LCMXO2280C-4T100C	2280	1.8V/2.5V/3.3V	73	-4	TQFP	100	COM
LCMXO2280C-5T100C	2280	1.8V/2.5V/3.3V	73	-5	TQFP	100	COM
LCMXO2280C-3T144C	2280	1.8V/2.5V/3.3V	113	-3	TQFP	144	COM
LCMXO2280C-4T144C	2280	1.8V/2.5V/3.3V	113	-4	TQFP	144	COM
LCMXO2280C-5T144C	2280	1.8V/2.5V/3.3V	113	-5	TQFP	144	COM
LCMXO2280C-3M132C	2280	1.8V/2.5V/3.3V	101	-3	csBGA	132	COM
LCMXO2280C-4M132C	2280	1.8V/2.5V/3.3V	101	-4	csBGA	132	COM
LCMXO2280C-5M132C	2280	1.8V/2.5V/3.3V	101	-5	csBGA	132	COM
LCMXO2280C-3B256C	2280	1.8V/2.5V/3.3V	211	-3	caBGA	256	COM
LCMXO2280C-4B256C	2280	1.8V/2.5V/3.3V	211	-4	caBGA	256	COM
LCMXO2280C-5B256C	2280	1.8V/2.5V/3.3V	211	-5	caBGA	256	COM
LCMXO2280C-3FT256C	2280	1.8V/2.5V/3.3V	211	-3	ftBGA	256	COM
LCMXO2280C-4FT256C	2280	1.8V/2.5V/3.3V	211	-4	ftBGA	256	COM
LCMXO2280C-5FT256C	2280	1.8V/2.5V/3.3V	211	-5	ftBGA	256	COM
LCMXO2280C-3FT324C	2280	1.8V/2.5V/3.3V	271	-3	ftBGA	324	COM
LCMXO2280C-4FT324C	2280	1.8V/2.5V/3.3V	271	-4	ftBGA	324	COM
LCMXO2280C-5FT324C	2280	1.8V/2.5V/3.3V	271	-5	ftBGA	324	COM

Part Number	LUTs	Supply Voltage	I/Os	Grade	Package	Pins	Temp.
LCMXO256E-3T100C	256	1.2V	78	-3	TQFP	100	COM
LCMXO256E-4T100C	256	1.2V	78	-4	TQFP	100	COM
LCMXO256E-5T100C	256	1.2V	78	-5	TQFP	100	COM
LCMXO256E-3M100C	256	1.2V	78	-3	csBGA	100	COM
LCMXO256E-4M100C	256	1.2V	78	-4	csBGA	100	COM
LCMXO256E-5M100C	256	1.2V	78	-5	csBGA	100	COM

Part Number	LUTs	Supply Voltage	I/Os	Grade	Package	Pins	Temp.
LCMXO640E-3T100C	640	1.2V	74	-3	TQFP	100	COM
LCMXO640E-4T100C	640	1.2V	74	-4	TQFP	100	COM
LCMXO640E-5T100C	640	1.2V	74	-5	TQFP	100	COM
LCMXO640E-3M100C	640	1.2V	74	-3	csBGA	100	COM
LCMXO640E-4M100C	640	1.2V	74	-4	csBGA	100	COM
LCMXO640E-5M100C	640	1.2V	74	-5	csBGA	100	COM
LCMXO640E-3T144C	640	1.2V	113	-3	TQFP	144	COM
LCMXO640E-4T144C	640	1.2V	113	-4	TQFP	144	COM
LCMXO640E-5T144C	640	1.2V	113	-5	TQFP	144	COM
LCMXO640E-3M132C	640	1.2V	101	-3	csBGA	132	COM
LCMXO640E-4M132C	640	1.2V	101	-4	csBGA	132	COM
LCMXO640E-5M132C	640	1.2V	101	-5	csBGA	132	COM
LCMXO640E-3B256C	640	1.2V	159	-3	caBGA	256	COM
LCMXO640E-4B256C	640	1.2V	159	-4	caBGA	256	COM
LCMXO640E-5B256C	640	1.2V	159	-5	caBGA	256	COM
LCMXO640E-3FT256C	640	1.2V	159	-3	ftBGA	256	COM
LCMXO640E-4FT256C	640	1.2V	159	-4	ftBGA	256	COM
LCMXO640E-5FT256C	640	1.2V	159	-5	ftBGA	256	COM

Lead-Free Packaging
Industrial

Part Number	LUTs	Supply Voltage	I/Os	Grade	Package	Pins	Temp.
LCMXO256C-3TN100I	256	1.8V/2.5V/3.3V	78	-3	Lead-Free TQFP	100	IND
LCMXO256C-4TN100I	256	1.8V/2.5V/3.3V	78	-4	Lead-Free TQFP	100	IND
LCMXO256C-3MN100I	256	1.8V/2.5V/3.3V	78	-3	Lead-Free csBGA	100	IND
LCMXO256C-4MN100I	256	1.8V/2.5V/3.3V	78	-4	Lead-Free csBGA	100	IND

Part Number	LUTs	Supply Voltage	I/Os	Grade	Package	Pins	Temp.
LCMXO640C-3TN100I	640	1.8V/2.5V/3.3V	74	-3	Lead-Free TQFP	100	IND
LCMXO640C-4TN100I	640	1.8V/2.5V/3.3V	74	-4	Lead-Free TQFP	100	IND
LCMXO640C-3MN100I	640	1.8V/2.5V/3.3V	74	-3	Lead-Free csBGA	100	IND
LCMXO640C-4MN100I	640	1.8V/2.5V/3.3V	74	-4	Lead-Free csBGA	100	IND
LCMXO640C-3TN144I	640	1.8V/2.5V/3.3V	113	-3	Lead-Free TQFP	144	IND
LCMXO640C-4TN144I	640	1.8V/2.5V/3.3V	113	-4	Lead-Free TQFP	144	IND
LCMXO640C-3MN132I	640	1.8V/2.5V/3.3V	101	-3	Lead-Free csBGA	132	IND
LCMXO640C-4MN132I	640	1.8V/2.5V/3.3V	101	-4	Lead-Free csBGA	132	IND
LCMXO640C-3BN256I	640	1.8V/2.5V/3.3V	159	-3	Lead-Free caBGA	256	IND
LCMXO640C-4BN256I	640	1.8V/2.5V/3.3V	159	-4	Lead-Free caBGA	256	IND
LCMXO640C-3FTN256I	640	1.8V/2.5V/3.3V	159	-3	Lead-Free ftBGA	256	IND
LCMXO640C-4FTN256I	640	1.8V/2.5V/3.3V	159	-4	Lead-Free ftBGA	256	IND

Part Number	LUTs	Supply Voltage	I/Os	Grade	Package	Pins	Temp.
LCMXO1200C-3TN100I	1200	1.8V/2.5V/3.3V	73	-3	Lead-Free TQFP	100	IND
LCMXO1200C-4TN100I	1200	1.8V/2.5V/3.3V	73	-4	Lead-Free TQFP	100	IND
LCMXO1200C-3TN144I	1200	1.8V/2.5V/3.3V	113	-3	Lead-Free TQFP	144	IND
LCMXO1200C-4TN144I	1200	1.8V/2.5V/3.3V	113	-4	Lead-Free TQFP	144	IND
LCMXO1200C-3MN132I	1200	1.8V/2.5V/3.3V	101	-3	Lead-Free csBGA	132	IND
LCMXO1200C-4MN132I	1200	1.8V/2.5V/3.3V	101	-4	Lead-Free csBGA	132	IND
LCMXO1200C-3BN256I	1200	1.8V/2.5V/3.3V	211	-3	Lead-Free caBGA	256	IND
LCMXO1200C-4BN256I	1200	1.8V/2.5V/3.3V	211	-4	Lead-Free caBGA	256	IND
LCMXO1200C-3FTN256I	1200	1.8V/2.5V/3.3V	211	-3	Lead-Free ftBGA	256	IND
LCMXO1200C-4FTN256I	1200	1.8V/2.5V/3.3V	211	-4	Lead-Free ftBGA	256	IND

Part Number	LUTs	Supply Voltage	I/Os	Grade	Package	Pins	Temp.
LCMXO2280C-3TN100I	2280	1.8V/2.5V/3.3V	73	-3	Lead-Free TQFP	100	IND
LCMXO2280C-4TN100I	2280	1.8V/2.5V/3.3V	73	-4	Lead-Free TQFP	100	IND
LCMXO2280C-3TN144I	2280	1.8V/2.5V/3.3V	113	-3	Lead-Free TQFP	144	IND
LCMXO2280C-4TN144I	2280	1.8V/2.5V/3.3V	113	-4	Lead-Free TQFP	144	IND
LCMXO2280C-3MN132I	2280	1.8V/2.5V/3.3V	101	-3	Lead-Free csBGA	132	IND
LCMXO2280C-4MN132I	2280	1.8V/2.5V/3.3V	101	-4	Lead-Free csBGA	132	IND
LCMXO2280C-3BN256I	2280	1.8V/2.5V/3.3V	211	-3	Lead-Free caBGA	256	IND
LCMXO2280C-4BN256I	2280	1.8V/2.5V/3.3V	211	-4	Lead-Free caBGA	256	IND
LCMXO2280C-3FTN256I	2280	1.8V/2.5V/3.3V	211	-3	Lead-Free ftBGA	256	IND
LCMXO2280C-4FTN256I	2280	1.8V/2.5V/3.3V	211	-4	Lead-Free ftBGA	256	IND
LCMXO2280C-3FTN324I	2280	1.8V/2.5V/3.3V	271	-3	Lead-Free ftBGA	324	IND
LCMXO2280C-4FTN324I	2280	1.8V/2.5V/3.3V	271	-4	Lead-Free ftBGA	324	IND

Date	Version	Section	Change Summary
April 2006 (cont.)	02.0 (cont.)	Architecture (cont.)	"Top View of the MachXO1200 Device" figure updated.
			"Top View of the MachXO640 Device" figure updated.
			"Top View of the MachXO256 Device" figure updated.
			"Slice Diagram" figure updated.
			Slice Signal Descriptions table updated.
			Routing section updated.
			sysCLOCK Phase Locked Loops (PLLs) section updated.
			PLL Diagram updated.
			PLL Signal Descriptions table updated.
			sysMEM Memory section has been updated.
			PIO Groups section has been updated.
			PIO section has been updated.
			MachXO PIO Block Diagram updated.
			Supported Input Standards table updated.
		MachXO Configuration and Programming diagram updated.	
		DC and Switching Characteristics	Recommended Operating Conditions table - footnotes updated.
			MachXO256 and MachXO640 Hot Socketing Specifications - footnotes updated.
			Added MachXO1200 and MachXO2280 Hot Socketing Specifications table.
			DC Electrical Characteristics, footnotes have been updated.
			Supply Current (Sleep Mode) table has been updated, removed "4W" references. Footnotes have been updated.
			Supply Current (Standby) table and associated footnotes updated.
			Initialization Supply Current table and footnotes updated.
			Programming and Erase Flash Supply Current table and associated footnotes have been updated.
			Register-to-Register Performance table updated (rev. A 0.19).
			MachXO External Switching Characteristics updated (rev. A 0.19).
			MachXO Internal Timing Parameters updated (rev. A 0.19).
			MachXO Family Timing Adders updated (rev. A 0.19).
			sysCLOCK Timing updated (rev. A 0.19).
			MachXO "C" Sleep Mode Timing updated (A 0.19).
		JTAG Port Timing Specification updated (rev. A 0.19).	
		Test Fixture Required Components table updated.	
		Pinout Information	Signal Descriptions have been updated.
			Pin Information Summary has been updated. Footnote has been added.
Power Supply and NC Connection table has been updated.			
Logic Signal Connections have been updated (PCLKTx_x --> PCLKx_x)			
Ordering Information	Removed "4W" references.		
	Added 256-ftBGA Ordering Part Numbers for MachXO640.		
May 2006	02.1	Pinout Information	Removed [LOC][0]_PLL_RST from Signal Description table.
			PCLK footnote has been added to all appropriate pins.
August 2006	02.2	Multiple	Removed 256 fpBGA information for MachXO640.

Date	Version	Section	Change Summary
November 2006	02.3	DC and Switching Characteristics	Corrections to MachXO “C” Sleep Mode Timing table - value for $t_{WSLEEPN}$ (400ns) changed from max. to min. Value for t_{WAWAKE} (100ns) changed from min. to max.
			Added Flash Download Time table.
December 2006	02.4	Architecture	EBR Asynchronous Reset section added.
		Pinout Information	Power Supply and NC table; Pin/Ball orientation footnotes added.
February 2007	02.5	Architecture	Updated EBR Asynchronous Reset section.
August 2007	02.6	DC and Switching Characteristics	Updated sysIO Single-Ended DC Electrical Characteristics table.
November 2007	02.7	DC and Switching Characteristics	Added JTAG Port Timing Waveforms diagram.
		Pinout Information	Added Thermal Management text section.
		Supplemental Information	Updated title list.
June 2009	02.8	Introduction	Added 0.8-mm 256-pin caBGA package to MachXO Family Selection Guide table.
		Pinout Information	Added Logic Signal Connections table for 0.8-mm 256-pin caBGA package.
		Ordering Information	Updated Part Number Description diagram and Ordering Part Number tables with 0.8-mm 256-pin caBGA package information.
July 2010	02.9	DC and Switching Characteristics	Updated sysCLOCK PLL Timing table.
June 2013	03.0	All	Updated document with new corporate logo.
		Architecture	Architecture Overview – Added information on the state of the register on power up and after configuration.
		DC and Switching Characteristics	MachXO1200 and MachXO2280 Hot Socketing Specifications table – Removed footnote 4. Added MachXO Programming/Erase Specifications table.