

Welcome to E-XFL.COM

Understanding [Embedded - FPGAs \(Field Programmable Gate Array\)](#)

Embedded - FPGAs, or Field Programmable Gate Arrays, are advanced integrated circuits that offer unparalleled flexibility and performance for digital systems. Unlike traditional fixed-function logic devices, FPGAs can be programmed and reprogrammed to execute a wide array of logical operations, enabling customized functionality tailored to specific applications. This reprogrammability allows developers to iterate designs quickly and implement complex functions without the need for custom hardware.

Applications of Embedded - FPGAs

The versatility of Embedded - FPGAs makes them indispensable in numerous fields. In telecommunications,

Details

Product Status	Obsolete
Number of LABs/CLBs	80
Number of Logic Elements/Cells	640
Total RAM Bits	-
Number of I/O	159
Number of Gates	-
Voltage - Supply	1.71V ~ 3.465V
Mounting Type	Surface Mount
Operating Temperature	0°C ~ 85°C (TJ)
Package / Case	256-LFBGA, CSPBGA
Supplier Device Package	256-CABGA (14x14)
Purchase URL	https://www.e-xfl.com/product-detail/lattice-semiconductor/lcmxo640c-3b256c

Features

- **Non-volatile, Infinitely Reconfigurable**
 - Instant-on – powers up in microseconds
 - Single chip, no external configuration memory required
 - Excellent design security, no bit stream to intercept
 - Reconfigure SRAM based logic in milliseconds
 - SRAM and non-volatile memory programmable through JTAG port
 - Supports background programming of non-volatile memory
- **Sleep Mode**
 - Allows up to 100x static current reduction
- **TransFR™ Reconfiguration (TFR)**
 - In-field logic update while system operates
- **High I/O to Logic Density**
 - 256 to 2280 LUT4s
 - 73 to 271 I/Os with extensive package options
 - Density migration supported
 - Lead free/RoHS compliant packaging
- **Embedded and Distributed Memory**
 - Up to 27.6 Kbits sysMEM™ Embedded Block RAM
 - Up to 7.7 Kbits distributed RAM
 - Dedicated FIFO control logic

- **Flexible I/O Buffer**
 - Programmable sysIO™ buffer supports wide range of interfaces:
 - LVCMOS 3.3/2.5/1.8/1.5/1.2
 - LVTTTL
 - PCI
 - LVDS, Bus-LVDS, LVPECL, RSDS
- **sysCLOCK™ PLLs**
 - Up to two analog PLLs per device
 - Clock multiply, divide, and phase shifting
- **System Level Support**
 - IEEE Standard 1149.1 Boundary Scan
 - Onboard oscillator
 - Devices operate with 3.3V, 2.5V, 1.8V or 1.2V power supply
 - IEEE 1532 compliant in-system programming

Introduction

The MachXO is optimized to meet the requirements of applications traditionally addressed by CPLDs and low capacity FPGAs: glue logic, bus bridging, bus interfacing, power-up control, and control logic. These devices bring together the best features of CPLD and FPGA devices on a single chip.

Table 1-1. MachXO Family Selection Guide

Device	LCMXO256	LCMXO640	LCMXO1200	LCMXO2280
LUTs	256	640	1200	2280
Dist. RAM (Kbits)	2.0	6.1	6.4	7.7
EBR SRAM (Kbits)	0	0	9.2	27.6
Number of EBR SRAM Blocks (9 Kbits)	0	0	1	3
V _{CC} Voltage	1.2/1.8/2.5/3.3V	1.2/1.8/2.5/3.3V	1.2/1.8/2.5/3.3V	1.2/1.8/2.5/3.3V
Number of PLLs	0	0	1	2
Max. I/O	78	159	211	271
Packages				
100-pin TQFP (14x14 mm)	78	74	73	73
144-pin TQFP (20x20 mm)		113	113	113
100-ball csBGA (8x8 mm)	78	74		
132-ball csBGA (8x8 mm)		101	101	101
256-ball caBGA (14x14 mm)		159	211	211
256-ball ftBGA (17x17 mm)		159	211	211
324-ball ftBGA (19x19 mm)				271

Architecture Overview

The MachXO family architecture contains an array of logic blocks surrounded by Programmable I/O (PIO). Some devices in this family have sysCLOCK PLLs and blocks of sysMEM™ Embedded Block RAM (EBRs). Figures 2-1, 2-2, and 2-3 show the block diagrams of the various family members.

The logic blocks are arranged in a two-dimensional grid with rows and columns. The EBR blocks are arranged in a column to the left of the logic array. The PIO cells are located at the periphery of the device, arranged into Banks. The PIOs utilize a flexible I/O buffer referred to as a sysIO interface that supports operation with a variety of interface standards. The blocks are connected with many vertical and horizontal routing channel resources. The place and route software tool automatically allocates these routing resources.

There are two kinds of logic blocks, the Programmable Functional Unit (PFU) and the Programmable Functional unit without RAM (PFF). The PFU contains the building blocks for logic, arithmetic, RAM, ROM, and register functions. The PFF block contains building blocks for logic, arithmetic, ROM, and register functions. Both the PFU and PFF blocks are optimized for flexibility, allowing complex designs to be implemented quickly and effectively. Logic blocks are arranged in a two-dimensional array. Only one type of block is used per row.

In the MachXO family, the number of sysIO Banks varies by device. There are different types of I/O Buffers on different Banks. See the details in later sections of this document. The sysMEM EBRs are large, dedicated fast memory blocks; these blocks are found only in the larger devices. These blocks can be configured as RAM, ROM or FIFO. FIFO support includes dedicated FIFO pointer and flag “hard” control logic to minimize LUT use.

The MachXO registers in PFU and sysI/O can be configured to be SET or RESET. After power up and device is configured, the device enters into user mode with these registers SET/RESET according to the configuration setting, allowing device entering to a known state for predictable system function.

The MachXO architecture provides up to two sysCLOCK™ Phase Locked Loop (PLL) blocks on larger devices. These blocks are located at either end of the memory blocks. The PLLs have multiply, divide, and phase shifting capabilities that are used to manage the frequency and phase relationships of the clocks.

Every device in the family has a JTAG Port that supports programming and configuration of the device as well as access to the user logic. The MachXO devices are available for operation from 3.3V, 2.5V, 1.8V, and 1.2V power supplies, providing easy integration into the overall system.

of the devices also support differential input buffers. PCI clamps are available on the top Bank I/O buffers. The PCI clamp is enabled after V_{CC} , V_{CCAUX} , and V_{CCIO} are at valid operating levels and the device has been configured.

The two pads in the pair are described as “true” and “comp”, where the true pad is associated with the positive side of the differential input buffer and the comp (complementary) pad is associated with the negative side of the differential input buffer.

2. Left and Right sysIO Buffer Pairs

The sysIO buffer pairs in the left and right Banks of the device consist of two single-ended output drivers and two sets of single-ended input buffers (supporting ratioed and absolute input levels). The devices also have a differential driver per output pair. The referenced input buffer can also be configured as a differential input buffer. In these Banks the two pads in the pair are described as “true” and “comp”, where the true pad is associated with the positive side of the differential I/O, and the comp (complementary) pad is associated with the negative side of the differential I/O.

Typical I/O Behavior During Power-up

The internal power-on-reset (POR) signal is deactivated when V_{CC} and V_{CCAUX} have reached satisfactory levels. After the POR signal is deactivated, the FPGA core logic becomes active. It is the user’s responsibility to ensure that all V_{CCIO} Banks are active with valid input logic levels to properly control the output logic states of all the I/O Banks that are critical to the application. The default configuration of the I/O pins in a blank device is tri-state with a weak pull-up to V_{CCIO} . The I/O pins will maintain the blank configuration until V_{CC} , V_{CCAUX} and V_{CCIO} have reached satisfactory levels at which time the I/Os will take on the user-configured settings.

The V_{CC} and V_{CCAUX} supply the power to the FPGA core fabric, whereas the V_{CCIO} supplies power to the I/O buffers. In order to simplify system design while providing consistent and predictable I/O behavior, the I/O buffers should be powered up along with the FPGA core fabric. Therefore, V_{CCIO} supplies should be powered up before or together with the V_{CC} and V_{CCAUX} supplies

Supported Standards

The MachXO sysIO buffer supports both single-ended and differential standards. Single-ended standards can be further subdivided into LVCMOS and LVTTTL. The buffer supports the LVTTTL, LVCMOS 1.2, 1.5, 1.8, 2.5, and 3.3V standards. In the LVCMOS and LVTTTL modes, the buffer has individually configurable options for drive strength, bus maintenance (weak pull-up, weak pull-down, bus-keeper latch or none) and open drain. BLVDS and LVPECL output emulation is supported on all devices. The MachXO1200 and MachXO2280 support on-chip LVDS output buffers on approximately 50% of the I/Os on the left and right Banks. Differential receivers for LVDS, BLVDS and LVPECL are supported on all Banks of MachXO1200 and MachXO2280 devices. PCI support is provided in the top Banks of the MachXO1200 and MachXO2280 devices. Table 2-8 summarizes the I/O characteristics of the devices in the MachXO family.

Tables 2-9 and 2-10 show the I/O standards (together with their supply and reference voltages) supported by the MachXO devices. For further information on utilizing the sysIO buffer to support a variety of standards please see the details of additional technical documentation at the end of this data sheet.

Table 2-10. Supported Output Standards

Output Standard	Drive	V _{CCIO} (Typ.)
Single-ended Interfaces		
LVTTTL	4mA, 8mA, 12mA, 16mA	3.3
LVC MOS33	4mA, 8mA, 12mA, 14mA	3.3
LVC MOS25	4mA, 8mA, 12mA, 14mA	2.5
LVC MOS18	4mA, 8mA, 12mA, 14mA	1.8
LVC MOS15	4mA, 8mA	1.5
LVC MOS12	2mA, 6mA	1.2
LVC MOS33, Open Drain	4mA, 8mA, 12mA, 14mA	—
LVC MOS25, Open Drain	4mA, 8mA, 12mA, 14mA	—
LVC MOS18, Open Drain	4mA, 8mA, 12mA, 14mA	—
LVC MOS15, Open Drain	4mA, 8mA	—
LVC MOS12, Open Drain	2mA, 6mA	—
PCI33 ³	N/A	3.3
Differential Interfaces		
LVDS ^{1,2}	N/A	2.5
BLVDS, RSDS ²	N/A	2.5
LVPECL ²	N/A	3.3

1. MachXO1200 and MachXO2280 devices have dedicated LVDS buffers.

2. These interfaces can be emulated with external resistors in all devices.

3. Top Banks of MachXO1200 and MachXO2280 devices only.

sysIO Buffer Banks

The number of Banks vary between the devices of this family. Eight Banks surround the two larger devices, the MachXO1200 and MachXO2280 (two Banks per side). The MachXO640 has four Banks (one Bank per side). The smallest member of this family, the MachXO256, has only two Banks.

Each sysIO buffer Bank is capable of supporting multiple I/O standards. Each Bank has its own I/O supply voltage (V_{CCIO}) which allows it to be completely independent from the other Banks. Figure 2-18, Figure 2-18, Figure 2-20 and Figure 2-21 shows the sysIO Banks and their associated supplies for all devices.

the system. These capabilities make the MachXO ideal for many multiple power supply and hot-swap applications.

Sleep Mode

The MachXO “C” devices ($V_{CC} = 1.8/2.5/3.3V$) have a sleep mode that allows standby current to be reduced dramatically during periods of system inactivity. Entry and exit to Sleep mode is controlled by the SLEEPN pin.

During Sleep mode, the logic is non-operational, registers and EBR contents are not maintained, and I/Os are tri-stated. Do not enter Sleep mode during device programming or configuration operation. In Sleep mode, power supplies are in their normal operating range, eliminating the need for external switching of power supplies. Table 2-11 compares the characteristics of Normal, Off and Sleep modes.

Table 2-11. Characteristics of Normal, Off and Sleep Modes

Characteristic	Normal	Off	Sleep
SLEEPN Pin	High	—	Low
Static Icc	Typical <10mA	0	Typical <100uA
I/O Leakage	<10μA	<1mA	<10μA
Power Supplies VCC/VCCIO/VCCAUX	Normal Range	0	Normal Range
Logic Operation	User Defined	Non Operational	Non operational
I/O Operation	User Defined	Tri-state	Tri-state
JTAG and Programming circuitry	Operational	Non-operational	Non-operational
EBR Contents and Registers	Maintained	Non-maintained	Non-maintained

SLEEPN Pin Characteristics

The SLEEPN pin behaves as an LVCMOS input with the voltage standard appropriate to the VCC supply for the device. This pin also has a weak pull-up, along with a Schmidt trigger and glitch filter to prevent false triggering. An external pull-up to VCC is recommended when Sleep Mode is not used to ensure the device stays in normal operation mode. Typically, the device enters sleep mode several hundred nanoseconds after SLEEPN is held at a valid low and restarts normal operation as specified in the Sleep Mode Timing table. The AC and DC specifications portion of this data sheet shows a detailed timing diagram.

Oscillator

Every MachXO device has an internal CMOS oscillator. The oscillator can be routed as an input clock to the clock tree or to general routing resources. The oscillator frequency can be divided by internal logic. There is a dedicated programming bit to enable/disable the oscillator. The oscillator frequency ranges from 18MHz to 26MHz.

Configuration and Testing

The following section describes the configuration and testing features of the MachXO family of devices.

IEEE 1149.1-Compliant Boundary Scan Testability

All MachXO devices have boundary scan cells that are accessed through an IEEE 1149.1 compliant test access port (TAP). This allows functional testing of the circuit board, on which the device is mounted, through a serial scan path that can access all critical logic nodes. Internal registers are linked internally, allowing test data to be shifted in and loaded directly onto test nodes, or test data to be captured and shifted out for verification. The test access port consists of dedicated I/Os: TDI, TDO, TCK and TMS. The test access port shares its power supply with one of the VCCIO Banks (MachXO256: V_{CCIO1} ; MachXO640: V_{CCIO2} ; MachXO1200 and MachXO2280: V_{CCIO5}) and can operate with LVCMOS3.3, 2.5, 1.8, 1.5, and 1.2 standards.

For more details on boundary scan test, please see information regarding additional technical documentation at the end of this data sheet.

Figure 2-22. MachXO Configuration and Programming

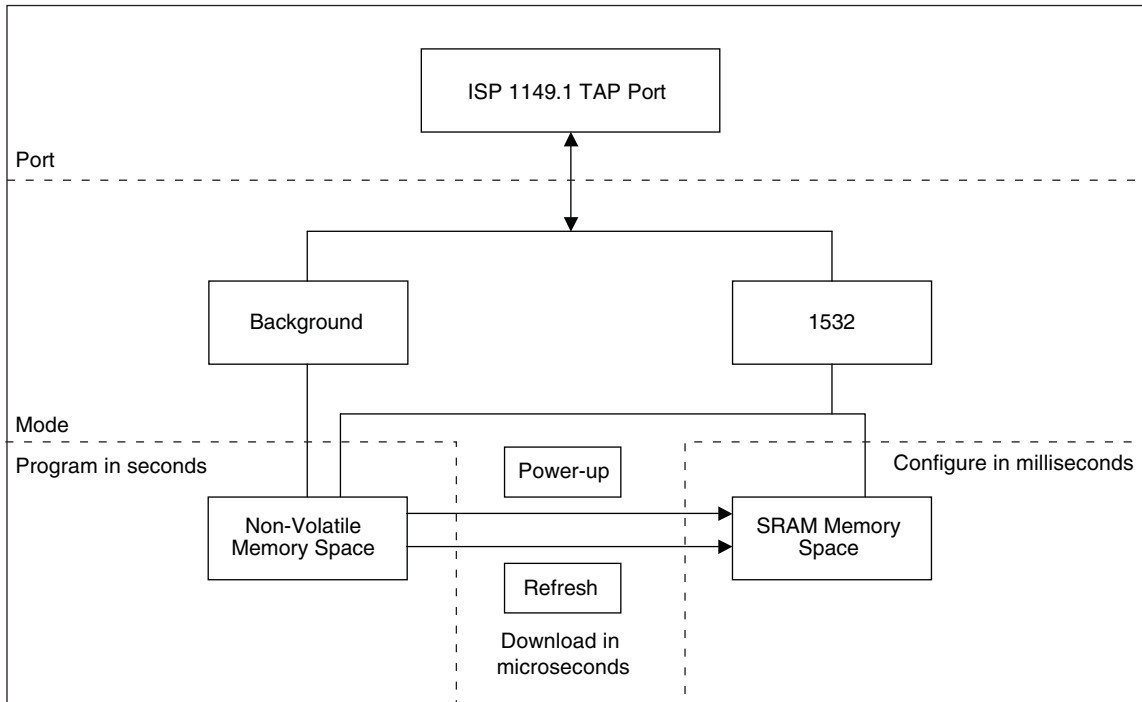

Density Shifting

The MachXO family has been designed to enable density migration in the same package. Furthermore, the architecture ensures a high success rate when performing design migration from lower density parts to higher density parts. In many cases, it is also possible to shift a lower utilization design targeted for a high-density device to a lower density device. However, the exact details of the final resource utilization will impact the likely success in each case.

sysIO Recommended Operating Conditions

Standard	V _{CCIO} (V)		
	Min.	Typ.	Max.
LVC MOS 3.3	3.135	3.3	3.465
LVC MOS 2.5	2.375	2.5	2.625
LVC MOS 1.8	1.71	1.8	1.89
LVC MOS 1.5	1.425	1.5	1.575
LVC MOS 1.2	1.14	1.2	1.26
LVTTL	3.135	3.3	3.465
PCI ³	3.135	3.3	3.465
LVDS ^{1,2}	2.375	2.5	2.625
LVPECL ¹	3.135	3.3	3.465
BLVDS ¹	2.375	2.5	2.625
RSDS ¹	2.375	2.5	2.625

1. Inputs on chip. Outputs are implemented with the addition of external resistors.
2. MachXO1200 and MachXO2280 devices have dedicated LVDS buffers
3. Input on the top bank of the MachXO1200 and MachXO2280 only.

sysIO Single-Ended DC Electrical Characteristics

Input/Output Standard	V _{IL}		V _{IH}		V _{OL} Max. (V)	V _{OH} Min. (V)	I _{OL} ¹ (mA)	I _{OH} ¹ (mA)
	Min. (V)	Max. (V)	Min. (V)	Max. (V)				
LVC MOS 3.3	-0.3	0.8	2.0	3.6	0.4	V _{CCIO} - 0.4	16, 12, 8, 4	-14, -12, -8, -4
					0.2	V _{CCIO} - 0.2	0.1	-0.1
LVTTL	-0.3	0.8	2.0	3.6	0.4	2.4	16	-16
					0.4	V _{CCIO} - 0.4	12, 8, 4	-12, -8, -4
LVC MOS 2.5	-0.3	0.7	1.7	3.6	0.4	V _{CCIO} - 0.4	16, 12, 8, 4	-14, -12, -8, -4
					0.2	V _{CCIO} - 0.2	0.1	-0.1
LVC MOS 1.8	-0.3	0.35V _{CCIO}	0.65V _{CCIO}	3.6	0.4	V _{CCIO} - 0.4	16, 12, 8, 4	-14, -12, -8, -4
					0.2	V _{CCIO} - 0.2	0.1	-0.1
LVC MOS 1.5	-0.3	0.35V _{CCIO}	0.65V _{CCIO}	3.6	0.4	V _{CCIO} - 0.4	8, 4	-8, -4
					0.2	V _{CCIO} - 0.2	0.1	-0.1
LVC MOS 1.2 ("C" Version)	-0.3	0.42	0.78	3.6	0.4	V _{CCIO} - 0.4	6, 2	-6, -2
					0.2	V _{CCIO} - 0.2	0.1	-0.1
LVC MOS 1.2 ("E" Version)	-0.3	0.35V _{CC}	0.65V _{CC}	3.6	0.4	V _{CCIO} - 0.4	6, 2	-6, -2
					0.2	V _{CCIO} - 0.2	0.1	-0.1
PCI	-0.3	0.3V _{CCIO}	0.5V _{CCIO}	3.6	0.1V _{CCIO}	0.9V _{CCIO}	1.5	-0.5

1. The average DC current drawn by I/Os between GND connections, or between the last GND in an I/O Bank and the end of an I/O Bank, as shown in the logic signal connections table shall not exceed n * 8mA. Where n is the number of I/Os between Bank GND connections or between the last GND in a Bank and the end of a Bank.

Table 3-2. BLVDS DC Conditions¹

Over Recommended Operating Conditions

Symbol	Description	Nominal		Units
		Zo = 45	Zo = 90	
Z _{OUT}	Output impedance	100	100	Ohms
R _{TLEFT}	Left end termination	45	90	Ohms
R _{TRIGHT}	Right end termination	45	90	Ohms
V _{OH}	Output high voltage	1.375	1.48	V
V _{OL}	Output low voltage	1.125	1.02	V
V _{OD}	Output differential voltage	0.25	0.46	V
V _{CM}	Output common mode voltage	1.25	1.25	V
I _{DC}	DC output current	11.2	10.2	mA

1. For input buffer, see LVDS table.

LVPECL

The MachXO family supports the differential LVPECL standard through emulation. This output standard is emulated using complementary LVCMOS outputs in conjunction with a parallel resistor across the driver outputs on all the devices. The LVPECL input standard is supported by the LVDS differential input buffer on certain devices. The scheme shown in Figure 3-3 is one possible solution for point-to-point signals.

Figure 3-3. Differential LVPECL

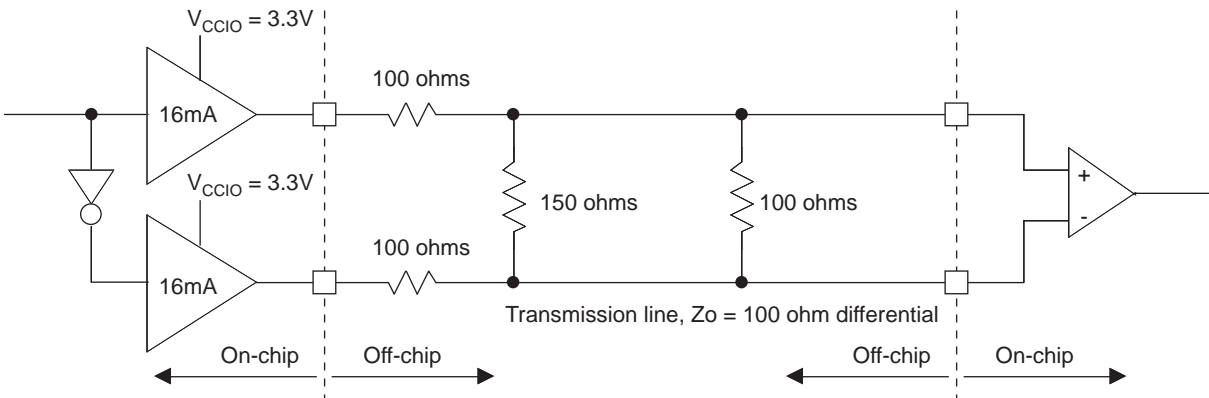

Table 3-3. LVPECL DC Conditions¹

Over Recommended Operating Conditions

Symbol	Description	Nominal	Units
Z _{OUT}	Output impedance	100	Ohms
R _P	Driver parallel resistor	150	Ohms
R _T	Receiver termination	100	Ohms
V _{OH}	Output high voltage	2.03	V
V _{OL}	Output low voltage	1.27	V
V _{OD}	Output differential voltage	0.76	V
V _{CM}	Output common mode voltage	1.65	V
Z _{BACK}	Back impedance	85.7	Ohms
I _{DC}	DC output current	12.7	mA

1. For input buffer, see LVDS table.

LCMX0256 and LCMX0640 Logic Signal Connections: 100 csBGA (Cont.)

LCMX0256					LCMX0640				
Ball Number	Ball Function	Bank	Dual Function	Differential	Ball Number	Ball Function	Bank	Dual Function	Differential
A4	GNDIO0	0			A4	GNDIO0	0		
B4	PT3A	0		T	B4	PT3B	0		C
A3	PT2F	0		C	A3	PT3A	0		T
B3	PT2E	0		T	B3	PT2F	0		C
A2	PT2D	0		C	A2	PT2E	0		T
C3	PT2C	0		T	C3	PT2B	0		C
A1	PT2B	0		C	A1	PT2C	0		
B2	PT2A	0		T	B2	PT2A	0		T
N9	GND	-			N9	GND	-		
B9	GND	-			B9	GND	-		
B5	VCCIO0	0			B5	VCCIO0	0		
A14	VCCIO0	0			A14	VCCIO1	1		
H14	VCCIO0	0			H14	VCCIO1	1		
P10	VCCIO1	1			P10	VCCIO2	2		
G1	VCCIO1	1			G1	VCCIO3	3		
P1	VCCIO1	1			P1	VCCIO3	3		

*NC for "E" devices.

**Primary clock inputs are single-ended.

**LCMXO640, LCMXO1200 and LCMXO2280 Logic Signal Connections:
 144 TQFP**

Pin Number	LCMXO640				LCMXO1200				LCMXO2280			
	Ball Function	Bank	Dual Function	Differential	Ball Function	Bank	Dual Function	Differential	Ball Function	Bank	Dual Function	Differential
1	PL2A	3		T	PL2A	7		T	PL2A	7	LUM0_PLLT_FB_A	T
2	PL2C	3		T	PL2B	7		C	PL2B	7	LUM0_PLLC_FB_A	C
3	PL2B	3		C	PL3A	7		T*	PL3A	7		T*
4	PL3A	3		T	PL3B	7		C*	PL3B	7		C*
5	PL2D	3		C	PL3C	7		T	PL3C	7	LUM0_PLLT_IN_A	T
6	PL3B	3		C	PL3D	7		C	PL3D	7	LUM0_PLLC_IN_A	C
7	PL3C	3		T	PL4A	7		T*	PL4A	7		T*
8	PL3D	3		C	PL4B	7		C*	PL4B	7		C*
9	PL4A	3			PL4C	7			PL4C	7		
10	VCCIO3	3			VCCIO7	7			VCCIO7	7		
11	GNDIO3	3			GNDIO7	7			GNDIO7	7		
12	PL4D	3			PL5C	7			PL6C	7		
13	PL5A	3		T	PL6A	7		T*	PL7A	7		T*
14	PL5B	3	GSRN	C	PL6B	7	GSRN	C*	PL7B	7	GSRN	C*
15	PL5D	3			PL6D	7			PL7D	7		
16	GND	-			GND	-			GND	-		
17	PL6C	3		T	PL7C	7		T	PL9C	7		T
18	PL6D	3		C	PL7D	7		C	PL9D	7		C
19	PL7A	3		T	PL10A	6		T*	PL13A	6		T*
20	PL7B	3		C	PL10B	6		C*	PL13B	6		C*
21	VCC	-			VCC	-			VCC	-		
22	PL8A	3		T	PL11A	6		T*	PL13D	6		
23	PL8B	3		C	PL11B	6		C*	PL14D	6		C
24	PL8C	3	TSALL		PL11C	6	TSALL		PL14C	6	TSALL	T
25	PL9C	3		T	PL12B	6			PL15B	6		
26	VCCIO3	3			VCCIO6	6			VCCIO6	6		
27	GNDIO3	3			GNDIO6	6			GNDIO6	6		
28	PL9D	3		C	PL13D	6			PL16D	6		
29	PL10A	3		T	PL14A	6	LLM0_PLLT_FB_A	T*	PL17A	6	LLM0_PLLT_FB_A	T*
30	PL10B	3		C	PL14B	6	LLM0_PLLC_FB_A	C*	PL17B	6	LLM0_PLLC_FB_A	C*
31	PL10C	3		T	PL14C	6		T	PL17C	6		T
32	PL11A	3		T	PL14D	6		C	PL17D	6		C
33	PL10D	3		C	PL15A	6	LLM0_PLLT_IN_A	T*	PL18A	6	LLM0_PLLT_IN_A	T*
34	PL11C	3		T	PL15B	6	LLM0_PLLC_IN_A	C*	PL18B	6	LLM0_PLLC_IN_A	C*
35	PL11B	3		C	PL16A	6		T	PL19A	6		T
36	PL11D	3		C	PL16B	6		C	PL19B	6		C
37	GNDIO2	2			GNDIO5	5			GNDIO5	5		
38	VCCIO2	2			VCCIO5	5			VCCIO5	5		
39	TMS	2	TMS		TMS	5	TMS		TMS	5	TMS	
40	PB2C	2			PB2C	5		T	PB2A	5		T
41	PB3A	2		T	PB2D	5		C	PB2B	5		C
42	TCK	2	TCK		TCK	5	TCK		TCK	5	TCK	
43	PB3B	2		C	PB3A	5		T	PB3A	5		T
44	PB3C	2		T	PB3B	5		C	PB3B	5		C
45	PB3D	2		C	PB4A	5		T	PB4A	5		T
46	PB4A	2		T	PB4B	5		C	PB4B	5		C
47	TDO	2	TDO		TDO	5	TDO		TDO	5	TDO	
48	PB4B	2		C	PB4D	5			PB4D	5		
49	PB4C	2		T	PB5A	5		T	PB5A	5		T
50	PB4D	2		C	PB5B	5		C	PB5B	5		C

**LCMXO640, LCMXO1200 and LCMXO2280 Logic Signal Connections:
 256 caBGA / 256 ftBGA (Cont.)**

LCMXO640					LCMXO1200					LCMXO2280				
Ball Number	Ball Function	Bank	Dual Function	Differential	Ball Number	Ball Function	Bank	Dual Function	Differential	Ball Number	Ball Function	Bank	Dual Function	Differential
J4	PL8A	3		T	J4	PL13A	6		T*	J4	PL16A	6		T*
J5	PL8B	3		C	J5	PL13B	6		C*	J5	PL16B	6		C*
R1	PL11A	3		T	R1	PL13C	6		T	R1	PL16C	6		T
R2	PL11B	3		C	R2	PL13D	6		C	R2	PL16D	6		C
-	-	-			-	-	-			GND	GND	-		
K5	NC				K5	PL14A	6	LLM0_PLLT_FB_A	T*	K5	PL17A	6	LLM0_PLLT_FB_A	T*
K4	NC				K4	PL14B	6	LLM0_PLLC_FB_A	C*	K4	PL17B	6	LLM0_PLLC_FB_A	C*
L5	PL10C	3		T	L5	PL14C	6		T	L5	PL17C	6		T
L4	PL10D	3		C	L4	PL14D	6		C	L4	PL17D	6		C
M5	NC				M5	PL15A	6	LLM0_PLLT_IN_A	T*	M5	PL18A	6	LLM0_PLLT_IN_A	T*
M4	NC				M4	PL15B	6	LLM0_PLLC_IN_A	C*	M4	PL18B	6	LLM0_PLLC_IN_A	C*
N4	PL11C	3		T	N4	PL16A	6		T	N4	PL19A	6		T
N3	PL11D	3		C	N3	PL16B	6		C	N3	PL19B	6		C
VCCIO3	VCCIO3	3			VCCIO6	VCCIO6	6			VCCIO6	VCCIO6	6		
GND	GNDIO3	3			GND	GNDIO6	6			GND	GNDIO6	6		
GND	GNDIO2	2			GND	GNDIO5	5			GND	GNDIO5	5		
VCCIO2	VCCIO2	2			VCCIO5	VCCIO5	5			VCCIO5	VCCIO5	5		
P4	TMS	2	TMS		P4	TMS	5	TMS		P4	TMS	5	TMS	
P2	NC				P2	PB2A	5		T	P2	PB2A	5		T
P3	NC				P3	PB2B	5		C	P3	PB2B	5		C
N5	NC				N5	PB2C	5		T	N5	PB2C	5		T
R3	TCK	2	TCK		R3	TCK	5	TCK		R3	TCK	5	TCK	
N6	NC				N6	PB2D	5		C	N6	PB2D	5		C
T2	PB2A	2		T	T2	PB3A	5		T	T2	PB3A	5		T
T3	PB2B	2		C	T3	PB3B	5		C	T3	PB3B	5		C
R4	PB2C	2		T	R4	PB3C	5		T	R4	PB3C	5		T
R5	PB2D	2		C	R5	PB3D	5		C	R5	PB3D	5		C
P5	PB3A	2		T	P5	PB4A	5		T	P5	PB4A	5		T
P6	PB3B	2		C	P6	PB4B	5		C	P6	PB4B	5		C
T5	PB3C	2		T	T5	PB4C	5		T	T5	PB4C	5		T
M6	TDO	2	TDO		M6	TDO	5	TDO		M6	TDO	5	TDO	
T4	PB3D	2		C	T4	PB4D	5		C	T4	PB4D	5		C
R6	PB4A	2		T	R6	PB5A	5		T	R6	PB5A	5		T
GND	GNDIO2	2			GND	GNDIO5	5			GND	GNDIO5	5		
VCCIO2	VCCIO2	2			VCCIO5	VCCIO5	5			VCCIO5	VCCIO5	5		
T6	PB4B	2		C	T6	PB5B	5		C	T6	PB5B	5		C
N7	TDI	2	TDI		N7	TDI	5	TDI		N7	TDI	5	TDI	
T8	PB4C	2		T	T8	PB5C	5		T	T8	PB6A	5		T
T7	PB4D	2		C	T7	PB5D	5		C	T7	PB6B	5		C
M7	NC				M7	PB6A	5		T	M7	PB7C	5		T
M8	NC				M8	PB6B	5		C	M8	PB7D	5		C
T9	VCCAUX	-			T9	VCCAUX	-			T9	VCCAUX	-		
R7	PB4E	2		T	R7	PB6C	5		T	R7	PB8C	5		T
R8	PB4F	2		C	R8	PB6D	5		C	R8	PB8D	5		C
-	-				VCCIO5	VCCIO5	5			VCCIO5	VCCIO5	5		
-	-				GND	GNDIO5	5			GND	GNDIO5	5		
P7	PB5C	2		T	P7	PB6E	5		T	P7	PB9A	4		T
P8	PB5D	2		C	P8	PB6F	5		C	P8	PB9B	4		C
N8	PB5A	2		T	N8	PB7A	4		T	N8	PB10E	4		T
N9	PB5B	2	PCLK2_1***	C	N9	PB7B	4	PCLK4_1***	C	N9	PB10F	4	PCLK4_1***	C
P10	PB7B	2		C	P10	PB7D	4		C	P10	PB10D	4		C
P9	PB7A	2		T	P9	PB7C	4		T	P9	PB10C	4		T
M9	PB6B	2	PCLK2_0***	C	M9	PB7F	4	PCLK4_0***	C	M9	PB10B	4	PCLK4_0***	C

LCMXO640, LCMXO1200 and LCMXO2280 Logic Signal Connections: 256 caBGA / 256 ftBGA (Cont.)

LCMXO640					LCMXO1200					LCMXO2280				
Ball Number	Ball Function	Bank	Dual Function	Differential	Ball Number	Ball Function	Bank	Dual Function	Differential	Ball Number	Ball Function	Bank	Dual Function	Differential
-	-				VCCIO4	VCCIO4	4			VCCIO4	VCCIO4	4		
-	-				GND	GNDIO4	4			GND	GNDIO4	4		
M10	PB6A	2		T	M10	PB7E	4		T	M10	PB10A	4		T
R9	PB6C	2		T	R9	PB8A	4		T	R9	PB11C	4		T
R10	PB6D	2		C	R10	PB8B	4		C	R10	PB11D	4		C
T10	PB7C	2		T	T10	PB8C	4		T	T10	PB12A	4		T
T11	PB7D	2		C	T11	PB8D	4		C	T11	PB12B	4		C
N10	NC				N10	PB8E	4		T	N10	PB12C	4		T
N11	NC				N11	PB8F	4		C	N11	PB12D	4		C
VCCIO2	VCCIO2	2			VCCIO4	VCCIO4	4			VCCIO4	VCCIO4	4		
GND	GNDIO2	2			GND	GNDIO4	4			GND	GNDIO4	4		
R11	PB7E	2		T	R11	PB9A	4		T	R11	PB13A	4		T
R12	PB7F	2		C	R12	PB9B	4		C	R12	PB13B	4		C
P11	PB8A	2		T	P11	PB9C	4		T	P11	PB13C	4		T
P12	PB8B	2		C	P12	PB9D	4		C	P12	PB13D	4		C
T13	PB8C	2		T	T13	PB9E	4		T	T13	PB14A	4		T
T12	PB8D	2		C	T12	PB9F	4		C	T12	PB14B	4		C
R13	PB9A	2		T	R13	PB10A	4		T	R13	PB14C	4		T
R14	PB9B	2		C	R14	PB10B	4		C	R14	PB14D	4		C
GND	GND	-			GND	GND	-			GND	GND	-		
T14	PB9C	2		T	T14	PB10C	4		T	T14	PB15A	4		T
T15	PB9D	2		C	T15	PB10D	4		C	T15	PB15B	4		C
P13**	SLEEPN	-	SLEEPN		P13**	SLEEPN	-	SLEEPN		P13**	SLEEPN	-	SLEEPN	
P14	PB9F	2			P14	PB10F	4			P14	PB15D	4		
R15	NC				R15	PB11A	4		T	R15	PB16A	4		T
R16	NC				R16	PB11B	4		C	R16	PB16B	4		C
P15	NC				P15	PB11C	4		T	P15	PB16C	4		T
P16	NC				P16	PB11D	4		C	P16	PB16D	4		C
VCCIO2	VCCIO2	2			VCCIO4	VCCIO4	4			VCCIO4	VCCIO4	4		
GND	GNDIO2	2			GND	GNDIO4	4			GND	GNDIO4	4		
GND	GNDIO1	1			GND	GNDIO3	3			GND	GNDIO3	3		
VCCIO1	VCCIO1	1			VCCIO3	VCCIO3	3			VCCIO3	VCCIO3	3		
M11	NC				M11	PR16B	3		C	M11	PR20B	3		C
L11	NC				L11	PR16A	3		T	L11	PR20A	3		T
N12	NC				N12	PR15B	3		C*	N12	PR18B	3		C*
N13	NC				N13	PR15A	3		T*	N13	PR18A	3		T*
M13	NC				M13	PR14D	3		C	M13	PR17D	3		C
M12	NC				M12	PR14C	3		T	M12	PR17C	3		T
N14	PR11D	1		C	N14	PR14B	3		C*	N14	PR17B	3		C*
N15	PR11C	1		T	N15	PR14A	3		T*	N15	PR17A	3		T*
L13	PR11B	1		C	L13	PR13D	3		T	L13	PR16D	3		C
L12	PR11A	1		T	L12	PR13C	3		C	L12	PR16C	3		T
M14	PR10B	1		C	M14	PR13B	3		C*	M14	PR16B	3		C*
VCCIO1	VCCIO1	1			VCCIO3	VCCIO3	3			VCCIO3	VCCIO3	3		
GND	GNDIO1	1			GND	GNDIO3	3			GND	GNDIO3	3		
L14	PR10A	1		T	L14	PR13A	3		T*	L14	PR16A	3		T*
N16	PR10D	1		C	N16	PR12D	3		C	N16	PR15D	3		C
M16	PR10C	1		T	M16	PR12C	3		T	M16	PR15C	3		T
M15	PR9D	1		C	M15	PR12B	3		C*	M15	PR15B	3		C*
L15	PR9C	1		T	L15	PR12A	3		T*	L15	PR15A	3		T*
L16	PR9B	1		C	L16	PR11D	3		C	L16	PR14D	3		C
K16	PR9A	1		T	K16	PR11C	3		T	K16	PR14C	3		T
K13	PR8D	1		C	K13	PR11B	3		C*	K13	PR14B	3		C*

LCMXO640, LCMXO1200 and LCMXO2280 Logic Signal Connections: 256 caBGA / 256 ftBGA (Cont.)

LCMXO640					LCMXO1200					LCMXO2280				
Ball Number	Ball Function	Bank	Dual Function	Differential	Ball Number	Ball Function	Bank	Dual Function	Differential	Ball Number	Ball Function	Bank	Dual Function	Differential
J13	PR8C	1		T	J13	PR11A	3		T*	J13	PR14A	3		T*
GND	GND	-			GND	GND	-			GND	GND	-		
K14	PR8B	1		C	K14	PR10D	3		C	K14	PR13D	3		C
J14	PR8A	1		T	J14	PR10C	3		T	J14	PR13C	3		T
K15	PR7D	1		C	K15	PR10B	3		C*	K15	PR13B	3		C*
J15	PR7C	1		T	J15	PR10A	3		T*	J15	PR13A	3		T*
-	-	-			GND	GNDIO3	3			GND	GNDIO3	3		
-	-	-			VCCIO3	VCCIO3	3			VCCIO3	VCCIO3	3		
K12	NC				K12	PR9D	3		C	K12	PR11D	3		C
J12	NC				J12	PR9C	3		T	J12	PR11C	3		T
J16	PR7B	1		C	J16	PR9B	3		C*	J16	PR11B	3		C*
H16	PR7A	1		T	H16	PR9A	3		T*	H16	PR11A	3		T*
H15	PR6B	1		C	H15	PR8D	2		C	H15	PR10D	2		C
G15	PR6A	1		T	G15	PR8C	2		T	G15	PR10C	2		T
H14	PR5D	1		C	H14	PR8B	2		C*	H14	PR10B	2		C*
G14	PR5C	1		T	G14	PR8A	2		T*	G14	PR10A	2		T*
GND	GNDIO1	1			GND	GNDIO2	2			GND	GNDIO2	2		
VCCIO1	VCCIO1	1			VCCIO2	VCCIO2	2			VCCIO2	VCCIO2	2		
H13	PR6D	1		C	H13	PR7D	2		C	H13	PR9D	2		C
H12	PR6C	1		T	H12	PR7C	2		T	H12	PR9C	2		T
G13	PR4D	1		C	G13	PR7B	2		C*	G13	PR9B	2		C*
G12	PR4C	1		T	G12	PR7A	2		T*	G12	PR9A	2		T*
G16	PR5B	1		C	G16	PR6D	2		C	G16	PR7D	2		C
F16	PR5A	1		T	F16	PR6C	2		T	F16	PR7C	2		T
F15	PR4B	1		C	F15	PR6B	2		C*	F15	PR7B	2		C*
E15	PR4A	1		T	E15	PR6A	2		T*	E15	PR7A	2		T*
E16	PR3B	1		C	E16	PR5D	2		C	E16	PR6D	2		C
D16	PR3A	1		T	D16	PR5C	2		T	D16	PR6C	2		T
VCCIO1	VCCIO1	1			VCCIO2	VCCIO2	2			VCCIO2	VCCIO2	2		
GND	GNDIO1	1			GND	GNDIO2	2			GND	GNDIO2	2		
D15	PR2D	1		C	D15	PR5B	2		C*	D15	PR6B	2		C*
C15	PR2C	1		T	C15	PR5A	2		T*	C15	PR6A	2		T*
C16	PR2B	1		C	C16	PR4D	2		C	C16	PR5D	2		C
B16	PR2A	1		T	B16	PR4C	2		T	B16	PR5C	2		T
F14	PR3D	1		C	F14	PR4B	2		C*	F14	PR5B	2		C*
E14	PR3C	1		T	E14	PR4A	2		T*	E14	PR5A	2		T*
-	-	-			-	-	-			GND	GND	-		
F12	NC				F12	PR3D	2		C	F12	PR4D	2		C
F13	NC				F13	PR3C	2		T	F13	PR4C	2		T
E12	NC				E12	PR3B	2		C*	E12	PR4B	2		C*
E13	NC				E13	PR3A	2		T*	E13	PR4A	2		T*
D13	NC				D13	PR2B	2		C	D13	PR3B	2		C*
D14	NC				D14	PR2A	2		T	D14	PR3A	2		T*
VCCIO0	VCCIO0	0			VCCIO2	VCCIO2	2			VCCIO2	VCCIO2	2		
GND	GNDIO0	0			GND	GNDIO2	2			GND	GNDIO2	2		
GND	GNDIO0	0			GND	GNDIO1	1			GND	GNDIO1	1		
VCCIO0	VCCIO0	0			VCCIO1	VCCIO1	1			VCCIO1	VCCIO1	1		
B15	NC				B15	PT11D	1		C	B15	PT16D	1		C
A15	NC				A15	PT11C	1		T	A15	PT16C	1		T
C14	NC				C14	PT11B	1		C	C14	PT16B	1		C
B14	NC				B14	PT11A	1		T	B14	PT16A	1		T
C13	PT9F	0		C	C13	PT10F	1		C	C13	PT15D	1		C
B13	PT9E	0		T	B13	PT10E	1		T	B13	PT15C	1		T

LCMX02280 Logic Signal Connections: 324 ftBGA (Cont.)

LCMX02280				
Ball Number	Ball Function	Bank	Dual Function	Differential
G2	PL11A	6		T*
H2	PL11B	6		C*
L3	PL11C	6		T
L5	PL11D	6		C
H1	PL12A	6		T*
VCCIO6	VCCIO6	6		
GND	GNDIO6	6		
J2	PL12B	6		C*
L4	PL12C	6		T
L6	PL12D	6		C
K2	PL13A	6		T*
K1	PL13B	6		C*
J1	PL13C	6		T
VCC	VCC	-		
L2	PL13D	6		C
M5	PL14D	6		C
M3	PL14C	6	TSALL	T
L1	PL14B	6		C*
M2	PL14A	6		T*
M1	PL15A	6		T*
N1	PL15B	6		C*
M6	PL15C	6		T
M4	PL15D	6		C
VCCIO6	VCCIO6	6		
GND	GNDIO6	6		
P1	PL16A	6		T*
P2	PL16B	6		C*
N3	PL16C	6		T
N4	PL16D	6		C
GND	GND	-		
T1	PL17A	6	LLM0_PLLT_FB_A	T*
R1	PL17B	6	LLM0_PLLC_FB_A	C*
P3	PL17C	6		T
N5	PL17D	6		C
R3	PL18A	6	LLM0_PLLT_IN_A	T*
R2	PL18B	6	LLM0_PLLC_IN_A	C*
P4	PL19A	6		T
N6	PL19B	6		C
U1	PL20A	6		T
VCCIO6	VCCIO6	6		
GND	GNDIO6	6		
GND	GNDIO5	5		
VCCIO5	VCCIO5	5		

LCMXO2280 Logic Signal Connections: 324 ftBGA (Cont.)

LCMXO2280				
Ball Number	Ball Function	Bank	Dual Function	Differential
V10	PB9B	4		C
N10	PB9C	4		T
R10	PB9D	4		C
P10	PB10F	4	PCLK4_1***	C
T10	PB10E	4		T
U10	PB10D	4		C
V11	PB10C	4		T
U11	PB10B	4	PCLK4_0***	C
VCCIO4	VCCIO4	4		
GND	GNDIO4	4		
T11	PB10A	4		T
U12	PB11A	4		T
R11	PB11B	4		C
GND	GND	-		
T12	PB11C	4		T
P11	PB11D	4		C
V12	PB12A	4		T
V13	PB12B	4		C
R12	PB12C	4		T
N11	PB12D	4		C
U13	PB12E	4		T
VCCIO4	VCCIO4	4		
GND	GNDIO4	4		
V14	PB12F	4		C
T13	PB13A	4		T
P12	PB13B	4		C
R13	PB13C	4		T
N12	PB13D	4		C
V15	PB14A	4		T
U14	PB14B	4		C
V16	PB14C	4		T
GND	GND	-		
T14	PB14D	4		C
U15	PB15A	4		T
V17	PB15B	4		C
P13**	SLEEPN	-	SLEEPN	
T15	PB15D	4		
U16	PB16A	4		T
V18	PB16B	4		C
N13	PB16C	4		T
R14	PB16D	4		C
VCCIO4	VCCIO4	4		
GND	GNDIO4	4		

LCMXO2280 Logic Signal Connections: 324 ftBGA (Cont.)

LCMXO2280				
Ball Number	Ball Function	Bank	Dual Function	Differential
J13	PR10C	2		T
M18	PR10B	2		C*
L18	PR10A	2		T*
GND	GNDIO2	2		
VCCIO2	VCCIO2	2		
H16	PR9D	2		C
H14	PR9C	2		T
K18	PR9B	2		C*
J18	PR9A	2		T*
J17	PR8D	2		C
VCC	VCC	-		
H18	PR8C	2		T
H17	PR8B	2		C*
G17	PR8A	2		T*
H13	PR7D	2		C
H15	PR7C	2		T
G18	PR7B	2		C*
F18	PR7A	2		T*
G14	PR6D	2		C
G16	PR6C	2		T
VCCIO2	VCCIO2	2		
GND	GNDIO2	2		
E18	PR6B	2		C*
F17	PR6A	2		T*
G13	PR5D	2		C
G15	PR5C	2		T
E17	PR5B	2		C*
E16	PR5A	2		T*
GND	GND	-		
F15	PR4D	2		C
E15	PR4C	2		T
D17	PR4B	2		C*
D18	PR4A	2		T*
B18	PR3D	2		C
C18	PR3C	2		T
C16	PR3B	2		C*
D16	PR3A	2		T*
C17	PR2B	2		C
D15	PR2A	2		T
VCCIO2	VCCIO2	2		
GND	GNDIO2	2		
GND	GNDIO1	1		
VCCIO1	VCCIO1	1		

LCMXO2280 Logic Signal Connections: 324 ftBGA (Cont.)

LCMXO2280				
Ball Number	Ball Function	Bank	Dual Function	Differential
A10	PT8E	0		T
VCCIO0	VCCIO0	0		
GND	GNDIO0	0		
A9	PT8D	0		C
C9	PT8C	0		T
B9	PT8B	0		C
F9	VCCAUX	-		
A8	PT8A	0		T
B8	PT7D	0		C
C8	PT7C	0		T
VCC	VCC	-		
A7	PT7B	0		C
B7	PT7A	0		T
A6	PT6A	0		T
B6	PT6B	0		C
D8	PT6C	0		T
F8	PT6D	0		C
C7	PT6E	0		T
E8	PT6F	0		C
D7	PT5D	0		C
VCCIO0	VCCIO0	0		
GND	GNDIO0	0		
E7	PT5C	0		T
A5	PT5B	0		C
C6	PT5A	0		T
B5	PT4A	0		T
A4	PT4B	0		C
D6	PT4C	0		T
F7	PT4D	0		C
B4	PT4E	0		T
GND	GND	-		
C5	PT4F	0		C
F6	PT3D	0		C
E5	PT3C	0		T
E6	PT3B	0		C
D5	PT3A	0		T
A3	PT2D	0		C
C4	PT2C	0		T
A2	PT2B	0		C
B2	PT2A	0		T
VCCIO0	VCCIO0	0		
GND	GNDIO0	0		
E14	GND	-		

Part Number	LUTs	Supply Voltage	I/Os	Grade	Package	Pins	Temp.
LCMXO1200E-3TN100C	1200	1.2V	73	-3	Lead-Free TQFP	100	COM
LCMXO1200E-4TN100C	1200	1.2V	73	-4	Lead-Free TQFP	100	COM
LCMXO1200E-5TN100C	1200	1.2V	73	-5	Lead-Free TQFP	100	COM
LCMXO1200E-3TN144C	1200	1.2V	113	-3	Lead-Free TQFP	144	COM
LCMXO1200E-4TN144C	1200	1.2V	113	-4	Lead-Free TQFP	144	COM
LCMXO1200E-5TN144C	1200	1.2V	113	-5	Lead-Free TQFP	144	COM
LCMXO1200E-3MN132C	1200	1.2V	101	-3	Lead-Free csBGA	132	COM
LCMXO1200E-4MN132C	1200	1.2V	101	-4	Lead-Free csBGA	132	COM
LCMXO1200E-5MN132C	1200	1.2V	101	-5	Lead-Free csBGA	132	COM
LCMXO1200E-3BN256C	1200	1.2V	211	-3	Lead-Free caBGA	256	COM
LCMXO1200E-4BN256C	1200	1.2V	211	-4	Lead-Free caBGA	256	COM
LCMXO1200E-5BN256C	1200	1.2V	211	-5	Lead-Free caBGA	256	COM
LCMXO1200E-3FTN256C	1200	1.2V	211	-3	Lead-Free ftBGA	256	COM
LCMXO1200E-4FTN256C	1200	1.2V	211	-4	Lead-Free ftBGA	256	COM
LCMXO1200E-5FTN256C	1200	1.2V	211	-5	Lead-Free ftBGA	256	COM

Part Number	LUTs	Supply Voltage	I/Os	Grade	Package	Pins	Temp.
LCMXO2280E-3TN100C	2280	1.2V	73	-3	Lead-Free TQFP	100	COM
LCMXO2280E-4TN100C	2280	1.2V	73	-4	Lead-Free TQFP	100	COM
LCMXO2280E-5TN100C	2280	1.2V	73	-5	Lead-Free TQFP	100	COM
LCMXO2280E-3TN144C	2280	1.2V	113	-3	Lead-Free TQFP	144	COM
LCMXO2280E-4TN144C	2280	1.2V	113	-4	Lead-Free TQFP	144	COM
LCMXO2280E-5TN144C	2280	1.2V	113	-5	Lead-Free TQFP	144	COM
LCMXO2280E-3MN132C	2280	1.2V	101	-3	Lead-Free csBGA	132	COM
LCMXO2280E-4MN132C	2280	1.2V	101	-4	Lead-Free csBGA	132	COM
LCMXO2280E-5MN132C	2280	1.2V	101	-5	Lead-Free csBGA	132	COM
LCMXO2280E-3BN256C	2280	1.2V	211	-3	Lead-Free caBGA	256	COM
LCMXO2280E-4BN256C	2280	1.2V	211	-4	Lead-Free caBGA	256	COM
LCMXO2280E-5BN256C	2280	1.2V	211	-5	Lead-Free caBGA	256	COM
LCMXO2280E-3FTN256C	2280	1.2V	211	-3	Lead-Free ftBGA	256	COM
LCMXO2280E-4FTN256C	2280	1.2V	211	-4	Lead-Free ftBGA	256	COM
LCMXO2280E-5FTN256C	2280	1.2V	211	-5	Lead-Free ftBGA	256	COM
LCMXO2280E-3FTN324C	2280	1.2V	271	-3	Lead-Free ftBGA	324	COM
LCMXO2280E-4FTN324C	2280	1.2V	271	-4	Lead-Free ftBGA	324	COM
LCMXO2280E-5FTN324C	2280	1.2V	271	-5	Lead-Free ftBGA	324	COM

Lead-Free Packaging
Industrial

Part Number	LUTs	Supply Voltage	I/Os	Grade	Package	Pins	Temp.
LCMXO256C-3TN100I	256	1.8V/2.5V/3.3V	78	-3	Lead-Free TQFP	100	IND
LCMXO256C-4TN100I	256	1.8V/2.5V/3.3V	78	-4	Lead-Free TQFP	100	IND
LCMXO256C-3MN100I	256	1.8V/2.5V/3.3V	78	-3	Lead-Free csBGA	100	IND
LCMXO256C-4MN100I	256	1.8V/2.5V/3.3V	78	-4	Lead-Free csBGA	100	IND

Part Number	LUTs	Supply Voltage	I/Os	Grade	Package	Pins	Temp.
LCMXO640C-3TN100I	640	1.8V/2.5V/3.3V	74	-3	Lead-Free TQFP	100	IND
LCMXO640C-4TN100I	640	1.8V/2.5V/3.3V	74	-4	Lead-Free TQFP	100	IND
LCMXO640C-3MN100I	640	1.8V/2.5V/3.3V	74	-3	Lead-Free csBGA	100	IND
LCMXO640C-4MN100I	640	1.8V/2.5V/3.3V	74	-4	Lead-Free csBGA	100	IND
LCMXO640C-3TN144I	640	1.8V/2.5V/3.3V	113	-3	Lead-Free TQFP	144	IND
LCMXO640C-4TN144I	640	1.8V/2.5V/3.3V	113	-4	Lead-Free TQFP	144	IND
LCMXO640C-3MN132I	640	1.8V/2.5V/3.3V	101	-3	Lead-Free csBGA	132	IND
LCMXO640C-4MN132I	640	1.8V/2.5V/3.3V	101	-4	Lead-Free csBGA	132	IND
LCMXO640C-3BN256I	640	1.8V/2.5V/3.3V	159	-3	Lead-Free caBGA	256	IND
LCMXO640C-4BN256I	640	1.8V/2.5V/3.3V	159	-4	Lead-Free caBGA	256	IND
LCMXO640C-3FTN256I	640	1.8V/2.5V/3.3V	159	-3	Lead-Free ftBGA	256	IND
LCMXO640C-4FTN256I	640	1.8V/2.5V/3.3V	159	-4	Lead-Free ftBGA	256	IND

Part Number	LUTs	Supply Voltage	I/Os	Grade	Package	Pins	Temp.
LCMXO1200C-3TN100I	1200	1.8V/2.5V/3.3V	73	-3	Lead-Free TQFP	100	IND
LCMXO1200C-4TN100I	1200	1.8V/2.5V/3.3V	73	-4	Lead-Free TQFP	100	IND
LCMXO1200C-3TN144I	1200	1.8V/2.5V/3.3V	113	-3	Lead-Free TQFP	144	IND
LCMXO1200C-4TN144I	1200	1.8V/2.5V/3.3V	113	-4	Lead-Free TQFP	144	IND
LCMXO1200C-3MN132I	1200	1.8V/2.5V/3.3V	101	-3	Lead-Free csBGA	132	IND
LCMXO1200C-4MN132I	1200	1.8V/2.5V/3.3V	101	-4	Lead-Free csBGA	132	IND
LCMXO1200C-3BN256I	1200	1.8V/2.5V/3.3V	211	-3	Lead-Free caBGA	256	IND
LCMXO1200C-4BN256I	1200	1.8V/2.5V/3.3V	211	-4	Lead-Free caBGA	256	IND
LCMXO1200C-3FTN256I	1200	1.8V/2.5V/3.3V	211	-3	Lead-Free ftBGA	256	IND
LCMXO1200C-4FTN256I	1200	1.8V/2.5V/3.3V	211	-4	Lead-Free ftBGA	256	IND

Part Number	LUTs	Supply Voltage	I/Os	Grade	Package	Pins	Temp.
LCMXO2280C-3TN100I	2280	1.8V/2.5V/3.3V	73	-3	Lead-Free TQFP	100	IND
LCMXO2280C-4TN100I	2280	1.8V/2.5V/3.3V	73	-4	Lead-Free TQFP	100	IND
LCMXO2280C-3TN144I	2280	1.8V/2.5V/3.3V	113	-3	Lead-Free TQFP	144	IND
LCMXO2280C-4TN144I	2280	1.8V/2.5V/3.3V	113	-4	Lead-Free TQFP	144	IND
LCMXO2280C-3MN132I	2280	1.8V/2.5V/3.3V	101	-3	Lead-Free csBGA	132	IND
LCMXO2280C-4MN132I	2280	1.8V/2.5V/3.3V	101	-4	Lead-Free csBGA	132	IND
LCMXO2280C-3BN256I	2280	1.8V/2.5V/3.3V	211	-3	Lead-Free caBGA	256	IND
LCMXO2280C-4BN256I	2280	1.8V/2.5V/3.3V	211	-4	Lead-Free caBGA	256	IND
LCMXO2280C-3FTN256I	2280	1.8V/2.5V/3.3V	211	-3	Lead-Free ftBGA	256	IND
LCMXO2280C-4FTN256I	2280	1.8V/2.5V/3.3V	211	-4	Lead-Free ftBGA	256	IND
LCMXO2280C-3FTN324I	2280	1.8V/2.5V/3.3V	271	-3	Lead-Free ftBGA	324	IND
LCMXO2280C-4FTN324I	2280	1.8V/2.5V/3.3V	271	-4	Lead-Free ftBGA	324	IND

Date	Version	Section	Change Summary
November 2006	02.3	DC and Switching Characteristics	Corrections to MachXO “C” Sleep Mode Timing table - value for $t_{WSLEEPN}$ (400ns) changed from max. to min. Value for t_{WAWAKE} (100ns) changed from min. to max. Added Flash Download Time table.
		Architecture	EBR Asynchronous Reset section added.
December 2006	02.4	Pinout Information	Power Supply and NC table; Pin/Ball orientation footnotes added.
February 2007	02.5	Architecture	Updated EBR Asynchronous Reset section.
August 2007	02.6	DC and Switching Characteristics	Updated sysIO Single-Ended DC Electrical Characteristics table.
November 2007	02.7	DC and Switching Characteristics	Added JTAG Port Timing Waveforms diagram.
		Pinout Information	Added Thermal Management text section.
		Supplemental Information	Updated title list.
June 2009	02.8	Introduction	Added 0.8-mm 256-pin caBGA package to MachXO Family Selection Guide table.
		Pinout Information	Added Logic Signal Connections table for 0.8-mm 256-pin caBGA package.
		Ordering Information	Updated Part Number Description diagram and Ordering Part Number tables with 0.8-mm 256-pin caBGA package information.
July 2010	02.9	DC and Switching Characteristics	Updated sysCLOCK PLL Timing table.
June 2013	03.0	All	Updated document with new corporate logo.
		Architecture	Architecture Overview – Added information on the state of the register on power up and after configuration.
		DC and Switching Characteristics	MachXO1200 and MachXO2280 Hot Socketing Specifications table – Removed footnote 4. Added MachXO Programming/Erase Specifications table.