

Welcome to [E-XFL.COM](https://www.e-xfl.com)

Understanding **Embedded - FPGAs (Field Programmable Gate Array)**

Embedded - FPGAs, or Field Programmable Gate Arrays, are advanced integrated circuits that offer unparalleled flexibility and performance for digital systems. Unlike traditional fixed-function logic devices, FPGAs can be programmed and reprogrammed to execute a wide array of logical operations, enabling customized functionality tailored to specific applications. This reprogrammability allows developers to iterate designs quickly and implement complex functions without the need for custom hardware.

Applications of Embedded - FPGAs

The versatility of Embedded - FPGAs makes them indispensable in numerous fields. In telecommunications,

Details

Product Status	Obsolete
Number of LABs/CLBs	80
Number of Logic Elements/Cells	640
Total RAM Bits	-
Number of I/O	159
Number of Gates	-
Voltage - Supply	1.71V ~ 3.465V
Mounting Type	Surface Mount
Operating Temperature	-40°C ~ 100°C (TJ)
Package / Case	256-LFBGA, CSPBGA
Supplier Device Package	256-CABGA (14x14)
Purchase URL	https://www.e-xfl.com/product-detail/lattice-semiconductor/lcmx0640c-3b256i

Figure 2-3. Top View of the MachXO256 Device

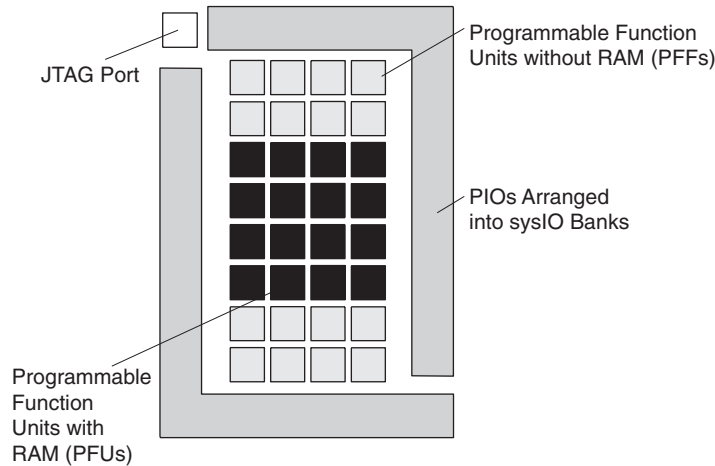

PFU Blocks

The core of the MachXO devices consists of PFU and PFF blocks. The PFUs can be programmed to perform Logic, Arithmetic, Distributed RAM, and Distributed ROM functions. PFF blocks can be programmed to perform Logic, Arithmetic, and Distributed ROM functions. Except where necessary, the remainder of this data sheet will use the term PFU to refer to both PFU and PFF blocks.

Each PFU block consists of four interconnected Slices, numbered 0-3 as shown in Figure 2-4. There are 53 inputs and 25 outputs associated with each PFU block.

Figure 2-4. PFU Diagram

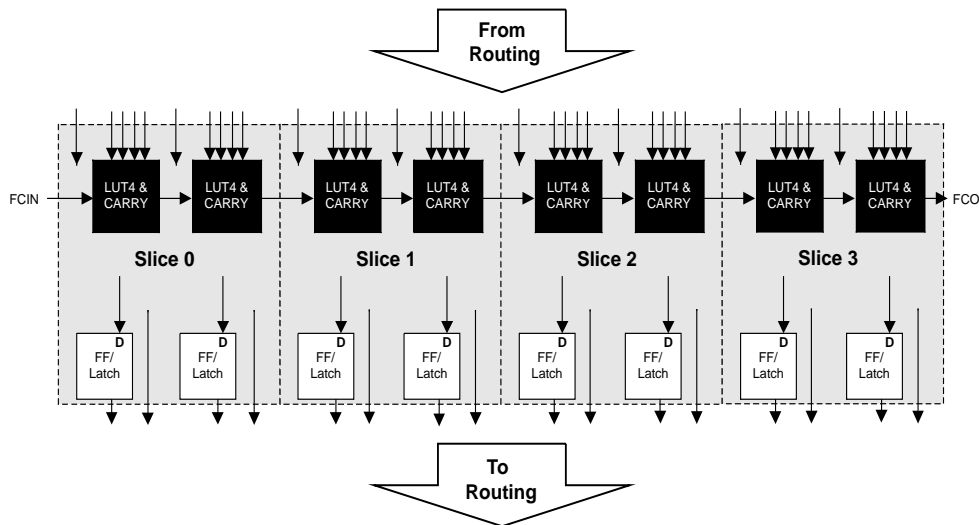

Slice

Each Slice contains two LUT4 lookup tables feeding two registers (programmed to be in FF or Latch mode), and some associated logic that allows the LUTs to be combined to perform functions such as LUT5, LUT6, LUT7, and LUT8. There is control logic to perform set/reset functions (programmable as synchronous/asynchronous), clock select, chip-select, and wider RAM/ROM functions. Figure 2-5 shows an overview of the internal logic of the Slice. The registers in the Slice can be configured for positive/negative and edge/level clocks.

Figure 2-8. Primary Clocks for MachXO1200 and MachXO2280 Devices



Four secondary clocks are generated from four 16:1 muxes as shown in Figure 2-9. Four of the secondary clock sources come from dual function clock pins and 12 come from internal routing.

Figure 2-9. Secondary Clocks for MachXO Devices



sysCLOCK Phase Locked Loops (PLLs)

The MachXO1200 and MachXO2280 provide PLL support. The source of the PLL input divider can come from an external pin or from internal routing. There are four sources of feedback signals to the feedback divider: from CLKINTFB (internal feedback port), from the global clock nets, from the output of the post scalar divider, and from the routing (or from an external pin). There is a PLL_LOCK signal to indicate that the PLL has locked on to the input clock signal. Figure 2-10 shows the sysCLOCK PLL diagram.

The setup and hold times of the device can be improved by programming a delay in the feedback or input path of the PLL which will advance or delay the output clock with reference to the input clock. This delay can be either programmed during configuration or can be adjusted dynamically. In dynamic mode, the PLL may lose lock after adjustment and not relock until the t_{LOCK} parameter has been satisfied. Additionally, the phase and duty cycle block allows the user to adjust the phase and duty cycle of the CLKOS output.

The sysCLOCK PLLs provide the ability to synthesize clock frequencies. Each PLL has four dividers associated with it: input clock divider, feedback divider, post scalar divider, and secondary clock divider. The input clock divider is used to divide the input clock signal, while the feedback divider is used to multiply the input clock signal. The post scalar divider allows the VCO to operate at higher frequencies than the clock output, thereby increasing the frequency range. The secondary divider is used to derive lower frequency outputs.

Figure 2-10. PLL Diagram

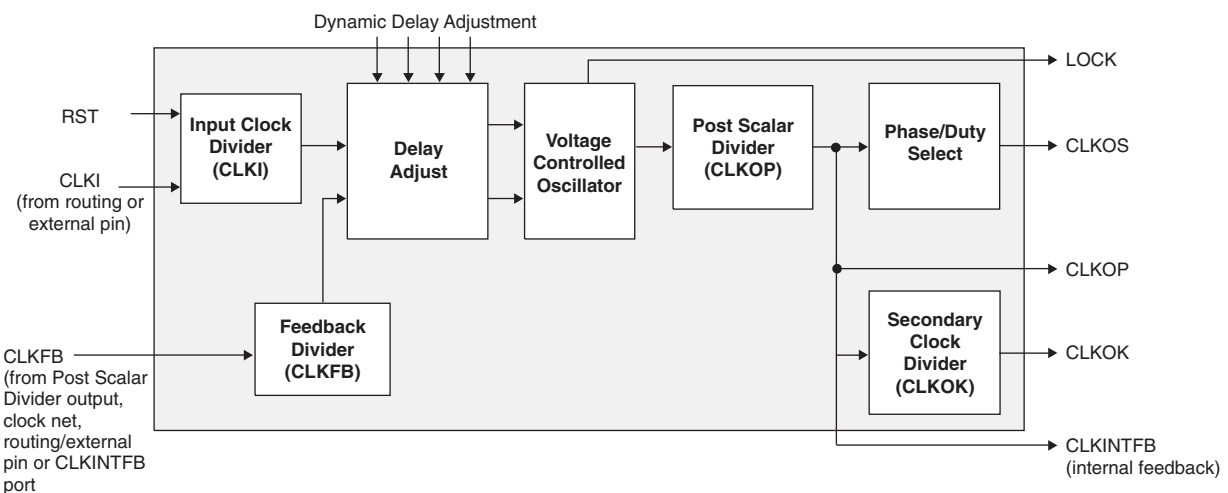

Figure 2-11 shows the available macros for the PLL. Table 2-5 provides signal description of the PLL Block.

Figure 2-11. PLL Primitive



PIO Groups

On the MachXO devices, PIO cells are assembled into two different types of PIO groups, those with four PIO cells and those with six PIO cells. PIO groups with four IOs are placed on the left and right sides of the device while PIO groups with six IOs are placed on the top and bottom. The individual PIO cells are connected to their respective sysIO buffers and PADs.

On all MachXO devices, two adjacent PIOs can be joined to provide a complementary Output driver pair. The I/O pin pairs are labeled as "T" and "C" to distinguish between the true and complement pins.

The MachXO1200 and MachXO2280 devices contain enhanced I/O capability. All PIO pairs on these larger devices can implement differential receivers. In addition, half of the PIO pairs on the left and right sides of these devices can be configured as LVDS transmit/receive pairs. PIOs on the top of these larger devices also provide PCI support.

Figure 2-15. Group of Four Programmable I/O Cells

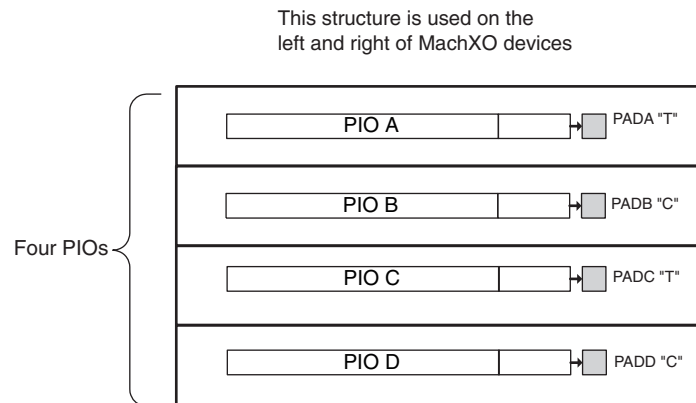
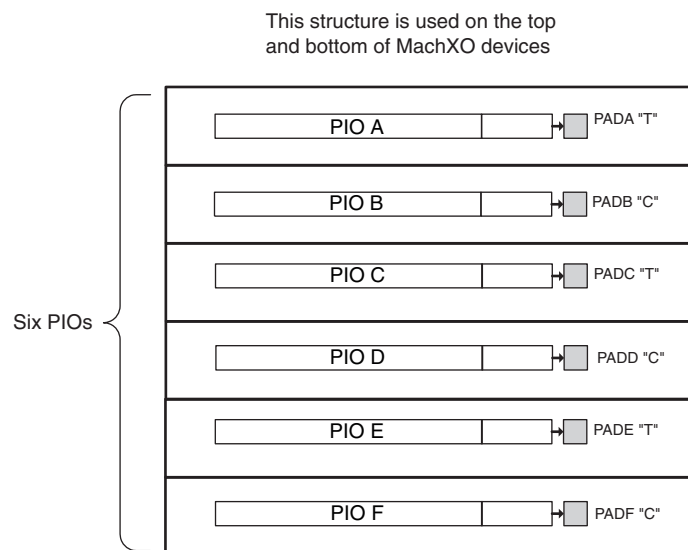

Figure 2-16. Group of Six Programmable I/O Cells



PIO

The PIO blocks provide the interface between the sysIO buffers and the internal PFU array blocks. These blocks receive output data from the PFU array and a fast output data signal from adjacent PFUs. The output data and fast

For further information on LVPECL, BLVDS and other differential interfaces please see details of additional technical documentation at the end of the data sheet.

RSDS

The MachXO family supports the differential RSDS standard. The output standard is emulated using complementary LVCMOS outputs in conjunction with a parallel resistor across the driver outputs on all the devices. The RSDS input standard is supported by the LVDS differential input buffer on certain devices. The scheme shown in Figure 3-4 is one possible solution for RSDS standard implementation. Use LVDS25E mode with suggested resistors for RSDS operation. Resistor values in Figure 3-4 are industry standard values for 1% resistors.

Figure 3-4. RSDS (Reduced Swing Differential Standard)

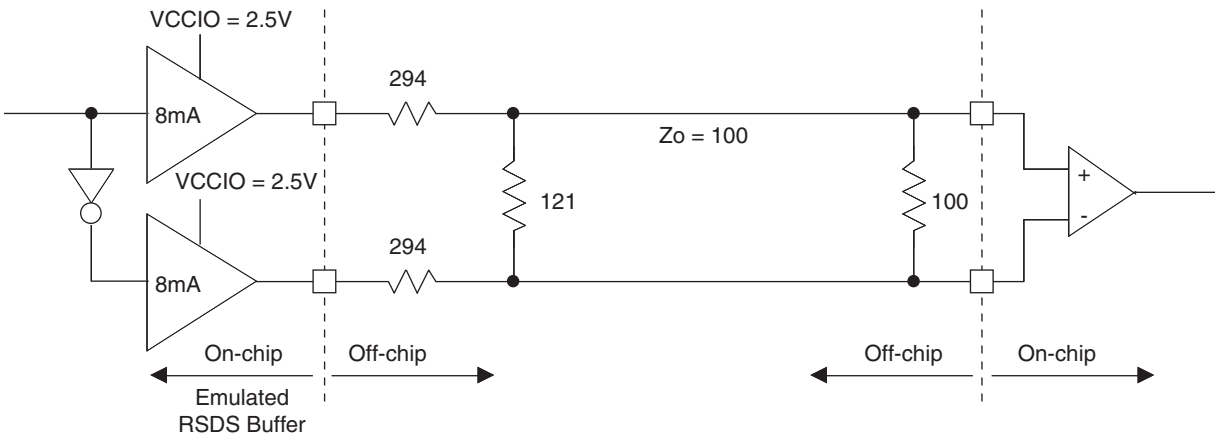

Table 3-4. RSDS DC Conditions

Parameter	Description	Typical	Units
Z_{OUT}	Output impedance	20	Ohms
R_S	Driver series resistor	294	Ohms
R_P	Driver parallel resistor	121	Ohms
R_T	Receiver termination	100	Ohms
V_{OH}	Output high voltage	1.35	V
V_{OL}	Output low voltage	1.15	V
V_{OD}	Output differential voltage	0.20	V
V_{CM}	Output common mode voltage	1.25	V
Z_{BACK}	Back impedance	101.5	Ohms
I_{DC}	DC output current	3.66	mA

MachXO External Switching Characteristics¹

Over Recommended Operating Conditions

Parameter	Description	Device	-5		-4		-3		Units
			Min.	Max.	Min.	Max.	Min.	Max.	
General I/O Pin Parameters (Using Global Clock without PLL)¹									
t _{PD}	Best Case t _{PD} Through 1 LUT	LCMXO256	—	3.5	—	4.2	—	4.9	ns
		LCMXO640	—	3.5	—	4.2	—	4.9	ns
		LCMXO1200	—	3.6	—	4.4	—	5.1	ns
		LCMXO2280	—	3.6	—	4.4	—	5.1	ns
t _{CO}	Best Case Clock to Output - From PFU	LCMXO256	—	4.0	—	4.8	—	5.6	ns
		LCMXO640	—	4.0	—	4.8	—	5.7	ns
		LCMXO1200	—	4.3	—	5.2	—	6.1	ns
		LCMXO2280	—	4.3	—	5.2	—	6.1	ns
t _{SU}	Clock to Data Setup - To PFU	LCMXO256	1.3	—	1.6	—	1.8	—	ns
		LCMXO640	1.1	—	1.3	—	1.5	—	ns
		LCMXO1200	1.1	—	1.3	—	1.6	—	ns
		LCMXO2280	1.1	—	1.3	—	1.5	—	ns
t _H	Clock to Data Hold - To PFU	LCMXO256	-0.3	—	-0.3	—	-0.3	—	ns
		LCMXO640	-0.1	—	-0.1	—	-0.1	—	ns
		LCMXO1200	0.0	—	0.0	—	0.0	—	ns
		LCMXO2280	-0.4	—	-0.4	—	-0.4	—	ns
f _{MAX_IO}	Clock Frequency of I/O and PFU Register	LCMXO256	—	600	—	550	—	500	MHz
		LCMXO640	—	600	—	550	—	500	MHz
		LCMXO1200	—	600	—	550	—	500	MHz
		LCMXO2280	—	600	—	550	—	500	MHz
t _{SKEW_PRI}	Global Clock Skew Across Device	LCMXO256	—	200	—	220	—	240	ps
		LCMXO640	—	200	—	220	—	240	ps
		LCMXO1200	—	220	—	240	—	260	ps
		LCMXO2280	—	220	—	240	—	260	ps

1. General timing numbers based on LVCMOS2.5V, 12 mA.
 Rev. A 0.19

MachXO Internal Timing Parameters¹

Over Recommended Operating Conditions

Parameter	Description	-5		-4		-3		Units
		Min.	Max.	Min.	Max.	Min.	Max.	
PFU/PFF Logic Mode Timing								
t _{LUT4_PFU}	LUT4 delay (A to D inputs to F output)	—	0.28	—	0.34	—	0.39	ns
t _{LUT6_PFU}	LUT6 delay (A to D inputs to OFX output)	—	0.44	—	0.53	—	0.62	ns
t _{LSR_PFU}	Set/Reset to output of PFU	—	0.90	—	1.08	—	1.26	ns
t _{SUM_PFU}	Clock to Mux (M0,M1) input setup time	0.10	—	0.13	—	0.15	—	ns
t _{HM_PFU}	Clock to Mux (M0,M1) input hold time	-0.05	—	-0.06	—	-0.07	—	ns
t _{SUD_PFU}	Clock to D input setup time	0.13	—	0.16	—	0.18	—	ns
t _{HD_PFU}	Clock to D input hold time	-0.03	—	-0.03	—	-0.04	—	ns
t _{CK2Q_PFU}	Clock to Q delay, D-type register configuration	—	0.40	—	0.48	—	0.56	ns
t _{LE2Q_PFU}	Clock to Q delay latch configuration	—	0.53	—	0.64	—	0.74	ns
t _{LD2Q_PFU}	D to Q throughput delay when latch is enabled	—	0.55	—	0.66	—	0.77	ns
PFU Dual Port Memory Mode Timing								
t _{CORAM_PFU}	Clock to Output	—	0.40	—	0.48	—	0.56	ns
t _{SUDATA_PFU}	Data Setup Time	-0.18	—	-0.22	—	-0.25	—	ns
t _{HDATA_PFU}	Data Hold Time	0.28	—	0.34	—	0.39	—	ns
t _{SUADDR_PFU}	Address Setup Time	-0.46	—	-0.56	—	-0.65	—	ns
t _{HADDR_PFU}	Address Hold Time	0.71	—	0.85	—	0.99	—	ns
t _{SUWREN_PFU}	Write/Read Enable Setup Time	-0.22	—	-0.26	—	-0.30	—	ns
t _{HWREN_PFU}	Write/Read Enable Hold Time	0.33	—	0.40	—	0.47	—	ns
PIO Input/Output Buffer Timing								
t _{IN_PIO}	Input Buffer Delay	—	0.75	—	0.90	—	1.06	ns
t _{OUT_PIO}	Output Buffer Delay	—	1.29	—	1.54	—	1.80	ns
EBR Timing (1200 and 2280 Devices Only)								
t _{CO_EBR}	Clock to output from Address or Data with no output register	—	2.24	—	2.69	—	3.14	ns
t _{COO_EBR}	Clock to output from EBR output Register	—	0.54	—	0.64	—	0.75	ns
t _{SUDATA_EBR}	Setup Data to EBR Memory	-0.26	—	-0.31	—	-0.37	—	ns
t _{HDATA_EBR}	Hold Data to EBR Memory	0.41	—	0.49	—	0.57	—	ns
t _{SUADDR_EBR}	Setup Address to EBR Memory	-0.26	—	-0.31	—	-0.37	—	ns
t _{HADDR_EBR}	Hold Address to EBR Memory	0.41	—	0.49	—	0.57	—	ns
t _{SUWREN_EBR}	Setup Write/Read Enable to EBR Memory	-0.17	—	-0.20	—	-0.23	—	ns
t _{HWREN_EBR}	Hold Write/Read Enable to EBR Memory	0.26	—	0.31	—	0.36	—	ns
t _{SUCE_EBR}	Clock Enable Setup Time to EBR Output Register	0.19	—	0.23	—	0.27	—	ns
t _{HCE_EBR}	Clock Enable Hold Time to EBR Output Register	-0.13	—	-0.16	—	-0.18	—	ns
t _{RSTO_EBR}	Reset To Output Delay Time from EBR Output Register	—	1.03	—	1.23	—	1.44	ns
PLL Parameters (1200 and 2280 Devices Only)								
t _{RSTREC}	Reset Recovery to Rising Clock	1.00	—	1.00	—	1.00	—	ns
t _{RSTSU}	Reset Signal Setup Time	1.00	—	1.00	—	1.00	—	ns

1. Internal parameters are characterized but not tested on every device.

Rev. A 0.19

Pin Information Summary

Pin Type		LCMXO256C/E		LCMXO640C/E				
		100 TQFP	100 csBGA	100 TQFP	144 TQFP	100 csBGA	132 csBGA	256 caBGA / 256 ftBGA
Single Ended User I/O		78	78	74	113	74	101	159
Differential Pair User I/O ¹		38	38	17	43	17	42	79
Muxed		6	6	6	6	6	6	6
TAP		4	4	4	4	4	4	4
Dedicated (Total Without Supplies)		5	5	5	5	5	5	5
VCC		2	2	2	4	2	4	4
VCCAUX		1	1	1	2	1	2	2
VCCIO	Bank0	3	3	2	2	2	2	4
	Bank1	3	3	2	2	2	2	4
	Bank2	—	—	2	2	2	2	4
	Bank3	—	—	2	2	2	2	4
GND		8	8	10	12	10	12	18
NC		0	0	0	0	0	0	52
Single Ended/Differential I/O per Bank	Bank0	41/20	41/20	18/5	29/10	18/5	26/11	42/21
	Bank1	37/18	37/18	21/4	30/11	21/4	27/12	40/20
	Bank2	—	—	14/2	24/9	14/2	21/9	36/18
	Bank3	—	—	21/6	30/13	21/6	27/10	40/20

1. These devices support emulated LVDS outputs. LVDS inputs are not supported.

Pin Type		LCMXO1200C/E				LCMXO2280C/E				
		100 TQFP	144 TQFP	132 csBGA	256 caBGA / 256 ftBGA	100 TQFP	144 TQFP	132 csBGA	256 caBGA / 256 ftBGA	324 ftBGA
Single Ended User I/O		73	113	101	211	73	113	101	211	271
Differential Pair User I/O ¹		27	48	42	105	30	47	41	105	134
Muxed		6	6	6	6	6	6	6	6	6
TAP		4	4	4	4	4	4	4	4	4
Dedicated (Total Without Supplies)		5	5	5	5	5	5	5	5	5
VCC		4	4	4	4	2	4	4	4	6
VCCAUX		2	2	2	2	2	2	2	2	2
VCCIO	Bank0	1	1	1	2	1	1	1	2	2
	Bank1	1	1	1	2	1	1	1	2	2
	Bank2	1	1	1	2	1	1	1	2	2
	Bank3	1	1	1	2	1	1	1	2	2
	Bank4	1	1	1	2	1	1	1	2	2
	Bank5	1	1	1	2	1	1	1	2	2
	Bank6	1	1	1	2	1	1	1	2	2
	Bank7	1	1	1	2	1	1	1	2	2
GND		8	12	12	18	8	12	12	18	24
NC		0	0	0	0	0	0	0	0	0
Single Ended/Differential I/O per Bank	Bank0	10/3	14/6	13/5	26/13	9/3	13/6	12/5	24/12	34/17
	Bank1	8/2	15/7	13/5	28/14	9/3	16/7	14/5	30/15	36/18
	Bank2	10/4	15/7	13/6	26/13	10/4	15/7	13/6	26/13	34/17
	Bank3	11/5	15/7	14/7	28/14	11/5	15/7	14/7	28/14	34/17
	Bank4	8/3	14/5	13/5	27/13	8/3	14/4	13/4	29/14	35/17
	Bank5	5/2	10/4	8/2	22/11	5/2	10/4	8/2	20/10	30/15
	Bank6	10/3	15/6	13/6	28/14	10/4	15/6	13/6	28/14	34/17
	Bank7	11/5	15/6	14/6	26/13	11/5	15/6	14/6	26/13	34/17

1. These devices support on-chip LVDS buffers for left and right I/O Banks.

LCMXO256 and LCMXO640 Logic Signal Connections: 100 TQFP (Cont.)

Pin Number	LCMXO256				LCMXO640			
	Ball Function	Bank	Dual Function	Differential	Ball Function	Bank	Dual Function	Differential
85	PT4B	0	PCLK0_1**	C	PT6B	0	PCLK0_1**	
86	PT4A	0	PCLK0_0**	T	PT5B	0	PCLK0_0**	C
87	PT3D	0		C	PT5A	0		T
88	VCCAUX	-			VCCAUX	-		
89	PT3C	0		T	PT4F	0		
90	VCC	-			VCC	-		
91	PT3B	0		C	PT3F	0		
92	VCCIO0	0			VCCIO0	0		
93	GNDIO0	0			GNDIO0	0		
94	PT3A	0		T	PT3B	0		C
95	PT2F	0		C	PT3A	0		T
96	PT2E	0		T	PT2F	0		C
97	PT2D	0		C	PT2E	0		T
98	PT2C	0		T	PT2B	0		C
99	PT2B	0		C	PT2C	0		
100	PT2A	0		T	PT2A	0		T

* NC for "E" devices.

** Primary clock inputs are single-ended.

LCMXO1200 and LCMXO2280 Logic Signal Connections: 100 TQFP (Cont.)

Pin Number	LCMXO1200				LCMXO2280			
	Ball Function	Bank	Dual Function	Differential	Ball Function	Bank	Dual Function	Differential
42	PB9A	4		T	PB12A	4		T
43	PB9B	4		C	PB12B	4		C
44	VCCIO4	4			VCCIO4	4		
45	PB10A	4		T	PB13A	4		T
46	PB10B	4		C	PB13B	4		C
47***	SLEEPN	-	SLEEPN		SLEEPN	-	SLEEPN	
48	PB11A	4		T	PB16A	4		T
49	PB11B	4		C	PB16B	4		C
50**	GNDIO3 GNDIO4	-			GNDIO3 GNDIO4	-		
51	PR16B	3			PR19B	3		
52	PR15B	3		C*	PR18B	3		C*
53	PR15A	3		T*	PR18A	3		T*
54	PR14B	3		C*	PR17B	3		C*
55	PR14A	3		T*	PR17A	3		T*
56	VCCIO3	3			VCCIO3	3		
57	PR12B	3		C*	PR15B	3		C*
58	PR12A	3		T*	PR15A	3		T*
59	GND	-			GND	-		
60	PR10B	3		C*	PR13B	3		C*
61	PR10A	3		T*	PR13A	3		T*
62	PR9B	3		C*	PR11B	3		C*
63	PR9A	3		T*	PR11A	3		T*
64	PR8B	2		C*	PR10B	2		C*
65	PR8A	2		T*	PR10A	2		T*
66	VCC	-			VCC	-		
67	PR6C	2			PR8C	2		
68	PR6B	2		C*	PR8B	2		C*
69	PR6A	2		T*	PR8A	2		T*
70	VCCIO2	2			VCCIO2	2		
71	PR4D	2			PR5D	2		
72	PR4B	2		C*	PR5B	2		C*
73	PR4A	2		T*	PR5A	2		T*
74	PR2B	2		C	PR3B	2		C*
75	PR2A	2		T	PR3A	2		T*
76**	GNDIO1 GNDIO2	-			GNDIO1 GNDIO2	-		
77	PT11C	1			PT15C	1		
78	PT11B	1		C	PT14B	1		C
79	PT11A	1		T	PT14A	1		T
80	VCCIO1	1			VCCIO1	1		
81	PT9E	1			PT12D	1		C

LCMX0256 and LCMX0640 Logic Signal Connections: 100 csBGA

LCMX0256					LCMX0640				
Ball Number	Ball Function	Bank	Dual Function	Differential	Ball Number	Ball Function	Bank	Dual Function	Differential
B1	PL2A	1		T	B1	PL2A	3		T
C1	PL2B	1		C	C1	PL2C	3		T
D2	PL3A	1		T	D2	PL2B	3		C
D1	PL3B	1		C	D1	PL2D	3		C
C2	PL3C	1		T	C2	PL3A	3		T
E1	PL3D	1		C	E1	PL3B	3		C
E2	PL4A	1		T	E2	PL3C	3		T
F1	PL4B	1		C	F1	PL3D	3		C
F2	PL5A	1		T	F2	PL4A	3		
G2	PL5B	1		C	G2	PL4C	3		T
H1	GNDIO1	1			H1	GNDIO3	3		
H2	PL5C	1		T	H2	PL4D	3		C
J1	PL5D	1	GSRN	C	J1	PL5B	3	GSRN	
J2	PL6A	1		T	J2	PL7B	3		
K1	PL6B	1	TSALL	C	K1	PL8C	3	TSALL	T
K2	PL7A	1		T	K2	PL8D	3		C
L1	PL7B	1		C	L1	PL9A	3		
L2	PL7C	1		T	L2	PL9C	3		
M1	PL7D	1		C	M1	PL10A	3		
M2	PL8A	1		T	M2	PL10C	3		
N1	PL8B	1		C	N1	PL11A	3		
M3	PL9A	1		T	M3	PL11C	3		
N2	GNDIO1	1			N2	GNDIO3	3		
P2	TMS	1	TMS		P2	TMS	2	TMS	
P3	PL9B	1		C	P3	PB2C	2		
N4	TCK	1	TCK		N4	TCK	2	TCK	
P4	PB2A	1		T	P4	VCCIO2	2		
N3	PB2B	1		C	N3	GNDIO2	2		
P5	TDO	1	TDO		P5	TDO	2	TDO	
N5	PB2C	1		T	N5	PB4C	2		
P6	TDI	1	TDI		P6	TDI	2	TDI	
N6	PB2D	1		C	N6	PB4E	2		
P7	VCC	-			P7	VCC	-		
N7	PB3A	1	PCLK1_1**	T	N7	PB5B	2	PCLK2_1**	
P8	PB3B	1		C	P8	PB5D	2		
N8	PB3C	1	PCLK1_0**	T	N8	PB6B	2	PCLK2_0**	
P9	PB3D	1		C	P9	PB6C	2		
N10	GNDIO1	1			N10	GNDIO2	2		
P11	PB4A	1		T	P11	PB8B	2		
N11	PB4B	1		C	N11	PB8C	2		T
P12	PB4C	1		T	P12	PB8D	2		C
N12	PB4D	1		C	N12	PB9A	2		

**LCMXO640, LCMXO1200 and LCMXO2280 Logic Signal Connections:
 132 csBGA**

LCMXO640					LCMXO1200					LCMXO2280				
Ball #	Ball Function	Bank	Dual Function	Differential	Ball #	Ball Function	Bank	Dual Function	Differential	Ball #	Ball Function	Bank	Dual Function	Differential
B1	PL2A	3		T	B1	PL2A	7		T	B1	PL2A	7	LUM0_PLLT_FB_A	T
C1	PL2B	3		C	C1	PL3C	7		T	C1	PL3C	7	LUM0_PLLT_IN_A	T
B2	PL2C	3		T	B2	PL2B	7		C	B2	PL2B	7	LUM0_PLLC_FB_A	C
C2	PL2D	3		C	C2	PL4A	7		T*	C2	PL4A	7		T*
C3	PL3A	3		T	C3	PL3D	7		C	C3	PL3D	7	LUM0_PLLC_IN_A	C
D1	PL3B	3		C	D1	PL4B	7		C*	D1	PL4B	7		C*
D3	PL3D	3			D3	PL4C	7			D3	PL4C	7		
E1	GNDIO3	3			E1	GNDIO7	7			E1	GNDIO7	7		
E2	PL5A	3		T	E2	PL6A	7		T*	E2	PL7A	7		T*
E3	PL5B	3	GSRN	C	E3	PL6B	7	GSRN	C*	E3	PL7B	7	GSRN	C*
F2	PL5D	3			F2	PL6D	7			F2	PL7D	7		
F3	PL6B	3			F3	PL7C	7		T	F3	PL9C	7		T
G1	PL6C	3		T	G1	PL7D	7		C	G1	PL9D	7		C
G2	PL6D	3		C	G2	PL8C	7		T	G2	PL10C	7		T
G3	PL7A	3		T	G3	PL8D	7		C	G3	PL10D	7		C
H2	PL7B	3		C	H2	PL10A	6		T*	H2	PL12A	6		T*
H1	PL7C	3			H1	PL10B	6		C*	H1	PL12B	6		C*
H3	VCC	-			H3	VCC	-			H3	VCC	-		
J1	PL8A	3			J1	PL11B	6			J1	PL14D	6		C
J2	PL8C	3	TSALL		J2	PL11C	6	TSALL	T	J2	PL14C	6	TSALL	T
J3	PL9A	3		T	J3	PL11D	6		C	J3	PL14B	6		
K2	PL9B	3		C	K2	PL12A	6		T*	K2	PL15A	6		T*
K1	PL9C	3			K1	PL12B	6		C*	K1	PL15B	6		C*
L2	GNDIO3	3			L2	GNDIO6	6			L2	GNDIO6	6		
L1	PL10A	3		T	L1	PL14A	6	LLM0_PLLT_FB_A	T*	L1	PL17A	6	LLM0_PLLT_FB_A	T*
L3	PL10B	3		C	L3	PL14B	6	LLM0_PLLC_FB_A	C*	L3	PL17B	6	LLM0_PLLC_FB_A	C*
M1	PL11A	3		T	M1	PL15A	6	LLM0_PLLT_IN_A	T*	M1	PL18A	6	LLM0_PLLT_IN_A	T*
N1	PL11B	3		C	N1	PL16A	6		T	N1	PL19A	6		T
M2	PL11C	3		T	M2	PL15B	6	LLM0_PLLC_IN_A	C*	M2	PL18B	6	LLM0_PLLC_IN_A	C*
P1	PL11D	3		C	P1	PL16B	6		C	P1	PL19B	6		C
P2	GNDIO2	2			P2	GNDIO5	5			P2	GNDIO5	5		
P3	TMS	2	TMS		P3	TMS	5	TMS		P3	TMS	5	TMS	
M3	PB2C	2		T	M3	PB2C	5		T	M3	PB2A	5		T
N3	PB2D	2		C	N3	PB2D	5		C	N3	PB2B	5		C
P4	TCK	2	TCK		P4	TCK	5	TCK		P4	TCK	5	TCK	
M4	PB3B	2			M4	PB3B	5			M4	PB3B	5		
N4	PB3C	2		T	N4	PB4A	5		T	N4	PB4A	5		T
P5	PB3D	2		C	P5	PB4B	5		C	P5	PB4B	5		C
N5	TDO	2	TDO		N5	TDO	5	TDO		N5	TDO	5	TDO	
M5	TDI	2	TDI		M5	TDI	5	TDI		M5	TDI	5	TDI	
N6	PB4E	2		T	N6	PB5C	5			N6	PB6C	5		
P6	VCC	-			P6	VCC	-			P6	VCC	-		
M6	PB4F	2		C	M6	PB6A	5			M6	PB8A	5		
P7	VCCAUX	-			P7	VCCAUX	-			P7	VCCAUX	-		
N7	PB5A	2		T	N7	PB6F	5			N7	PB8F	5		
M7	PB5B	2	PCLK2_1***	C	M7	PB7B	4	PCLK4_1***		M7	PB10F	4	PCLK4_1***	
N8	PB5D	2			N8	PB7C	4		T	N8	PB10C	4		T
P8	PB6A	2		T	P8	PB7D	4		C	P8	PB10D	4		C
M8	PB6B	2	PCLK2_0***	C	M8	PB7F	4	PCLK4_0***		M8	PB10B	4	PCLK4_0***	
N9	PB7A	2		T	N9	PB9A	4		T	N9	PB12A	4		T

LCMXO640, LCMXO1200 and LCMXO2280 Logic Signal Connections: 132 csBGA (Cont.)

LCMXO640					LCMXO1200					LCMXO2280				
Ball #	Ball Function	Bank	Dual Function	Differential	Ball #	Ball Function	Bank	Dual Function	Differential	Ball #	Ball Function	Bank	Dual Function	Differential
M9	PB7B	2		C	M9	PB9B	4		C	M9	PB12B	4		C
N10	PB7E	2		T	N10	PB9C	4		T	N10	PB12C	4		T
P10	PB7F	2		C	P10	PB9D	4		C	P10	PB12D	4		C
N11	GNDIO2	2			N11	GNDIO4	4			N11	GNDIO4	4		
P11	PB8C	2		T	P11	PB10A	4		T	P11	PB13C	4		T
M11	PB8D	2		C	M11	PB10B	4		C	M11	PB13D	4		C
P12	PB9C	2		T	P12	PB10C	4			P12	PB15B	4		
P13	PB9D	2		C	P13	PB11C	4		T	P13	PB16C	4		T
N12**	SLEEPN	-	SLEEPN		N12**	SLEEPN	-	SLEEPN		N12**	SLEEPN	-	SLEEPN	
P14	PB9F	2			P14	PB11D	4		C	P14	PB16D	4		C
N14	PR11D	1		C	N14	PR16B	3		C	N14	PR19B	3		C
M14	PR11C	1		T	M14	PR15B	3		C*	M14	PR18B	3		C*
N13	PR11B	1		C	N13	PR16A	3		T	N13	PR19A	3		T
M12	PR11A	1		T	M12	PR15A	3		T*	M12	PR18A	3		T*
M13	PR10B	1		C	M13	PR14B	3		C*	M13	PR17B	3		C*
L14	PR10A	1		T	L14	PR14A	3		T*	L14	PR17A	3		T*
L13	GNDIO1	1			L13	GNDIO3	3			L13	GNDIO3	3		
K14	PR8D	1		C	K14	PR12B	3		C*	K14	PR15B	3		C*
K13	PR8C	1		T	K13	PR12A	3		T*	K13	PR15A	3		T*
K12	PR8B	1		C	K12	PR11B	3		C*	K12	PR14B	3		C*
J13	PR8A	1		T	J13	PR11A	3		T*	J13	PR14A	3		T*
J12	PR7C	1			J12	PR10B	3		C*	J12	PR13B	3		C*
H14	PR7B	1		C	H14	PR10A	3		T*	H14	PR13A	3		T*
H13	PR7A	1		T	H13	PR9B	3		C*	H13	PR11B	3		C*
H12	PR6D	1		C	H12	PR9A	3		T*	H12	PR11A	3		T*
G13	PR6C	1		T	G13	PR8B	2		C*	G13	PR10B	2		C*
G14	PR6B	1			G14	PR8A	2		T*	G14	PR10A	2		T*
G12	VCC	-			G12	VCC	-			G12	VCC	-		
F14	PR5D	1		C	F14	PR6C	2			F14	PR8C	2		
F13	PR5C	1		T	F13	PR6B	2		C*	F13	PR8B	2		C*
F12	PR4D	1		C	F12	PR6A	2		T*	F12	PR8A	2		T*
E13	PR4C	1		T	E13	PR5B	2		C*	E13	PR7B	2		C*
E14	PR4B	1			E14	PR5A	2		T*	E14	PR7A	2		T*
D13	GNDIO1	1			D13	GNDIO2	2			D13	GNDIO2	2		
D14	PR3D	1		C	D14	PR4B	2		C*	D14	PR5B	2		C*
D12	PR3C	1		T	D12	PR4A	2		T*	D12	PR5A	2		T*
C14	PR2D	1		C	C14	PR3D	2		C	C14	PR4D	2		C
B14	PR2C	1		T	B14	PR2B	2		C	B14	PR3B	2		C*
C13	PR2B	1		C	C13	PR3C	2		T	C13	PR4C	2		T
A14	PR2A	1		T	A14	PR2A	2		T	A14	PR3A	2		T*
A13	PT9F	0		C	A13	PT11D	1		C	A13	PT16D	1		C
A12	PT9E	0		T	A12	PT11B	1		C	A12	PT16B	1		C
B13	PT9D	0		C	B13	PT11C	1		T	B13	PT16C	1		T
B12	PT9C	0		T	B12	PT10F	1			B12	PT15D	1		
C12	PT9B	0		C	C12	PT11A	1		T	C12	PT16A	1		T
A11	PT9A	0		T	A11	PT10D	1		C	A11	PT14B	1		C
C11	PT8C	0			C11	PT10C	1		T	C11	PT14A	1		T
A10	GNDIO0	0			A10	GNDIO1	1			A10	GNDIO1	1		
B10	PT7F	0		C	B10	PT9F	1		C	B10	PT12F	1		C
C10	PT7E	0		T	C10	PT9E	1		T	C10	PT12E	1		T

LCMXO640, LCMXO1200 and LCMXO2280 Logic Signal Connections: 132 csBGA (Cont.)

LCMXO640					LCMXO1200					LCMXO2280				
Ball #	Ball Function	Bank	Dual Function	Differential	Ball #	Ball Function	Bank	Dual Function	Differential	Ball #	Ball Function	Bank	Dual Function	Differential
B9	PT7B	0		C	B9	PT9B	1		C	B9	PT12D	1		C
A9	PT7A	0		T	A9	PT9A	1		T	A9	PT12C	1		T
A8	PT6B	0	PCLK0_1***	C	A8	PT7D	1	PCLK1_1***		A8	PT10B	1	PCLK1_1***	
B8	PT6A	0		T	B8	PT7B	1			B8	PT9D	1		
C8	PT5B	0	PCLK0_0***	C	C8	PT6F	0	PCLK1_0***		C8	PT9B	1	PCLK1_0***	
B7	PT5A	0		T	B7	PT6D	0			B7	PT8D	0		
A7	VCCAUX	-			A7	VCCAUX	-			A7	VCCAUX	-		
C7	VCC	-			C7	VCC	-			C7	VCC	-		
A6	PT4D	0		C	A6	PT5D	0		C	A6	PT7B	0		C
B6	PT4C	0		T	B6	PT5C	0		T	B6	PT7A	0		T
C6	PT3F	0		C	C6	PT5B	0		C	C6	PT6D	0		
B5	PT3E	0		T	B5	PT5A	0		T	B5	PT6E	0		T
A5	PT3D	0			A5	PT4B	0			A5	PT6F	0		C
B4	GNDIO0	0			B4	GNDIO0	0			B4	GNDIO0	0		
A4	PT3B	0			A4	PT3D	0		C	A4	PT4B	0		C
C4	PT2F	0			C4	PT3C	0		T	C4	PT4A	0		T
A3	PT2D	0		C	A3	PT3B	0		C	A3	PT3B	0		C
A2	PT2C	0		T	A2	PT2B	0		C	A2	PT2B	0		C
B3	PT2B	0		C	B3	PT3A	0		T	B3	PT3A	0		T
A1	PT2A	0		T	A1	PT2A	0		T	A1	PT2A	0		T
F1	GND	-			F1	GND	-			F1	GND	-		
P9	GND	-			P9	GND	-			P9	GND	-		
J14	GND	-			J14	GND	-			J14	GND	-		
C9	GND	-			C9	GND	-			C9	GND	-		
C5	VCCIO0	0			C5	VCCIO0	0			C5	VCCIO0	0		
B11	VCCIO0	0			B11	VCCIO1	1			B11	VCCIO1	1		
E12	VCCIO1	1			E12	VCCIO2	2			E12	VCCIO2	2		
L12	VCCIO1	1			L12	VCCIO3	3			L12	VCCIO3	3		
M10	VCCIO2	2			M10	VCCIO4	4			M10	VCCIO4	4		
N2	VCCIO2	2			N2	VCCIO5	5			N2	VCCIO5	5		
D2	VCCIO3	3			D2	VCCIO7	7			D2	VCCIO7	7		
K3	VCCIO3	3			K3	VCCIO6	6			K3	VCCIO6	6		

*Supports true LVDS outputs.

**NC for "E" devices.

***Primary clock inputs are single-ended.

**LCMXO640, LCMXO1200 and LCMXO2280 Logic Signal Connections:
 256 caBGA / 256 ftBGA (Cont.)**

LCMXO640					LCMXO1200					LCMXO2280				
Ball Number	Ball Function	Bank	Dual Function	Differential	Ball Number	Ball Function	Bank	Dual Function	Differential	Ball Number	Ball Function	Bank	Dual Function	Differential
J13	PR8C	1		T	J13	PR11A	3		T*	J13	PR14A	3		T*
GND	GND	-			GND	GND	-			GND	GND	-		
K14	PR8B	1		C	K14	PR10D	3		C	K14	PR13D	3		C
J14	PR8A	1		T	J14	PR10C	3		T	J14	PR13C	3		T
K15	PR7D	1		C	K15	PR10B	3		C*	K15	PR13B	3		C*
J15	PR7C	1		T	J15	PR10A	3		T*	J15	PR13A	3		T*
-	-	-			GND	GNDIO3	3			GND	GNDIO3	3		
-	-	-			VCCIO3	VCCIO3	3			VCCIO3	VCCIO3	3		
K12	NC				K12	PR9D	3		C	K12	PR11D	3		C
J12	NC				J12	PR9C	3		T	J12	PR11C	3		T
J16	PR7B	1		C	J16	PR9B	3		C*	J16	PR11B	3		C*
H16	PR7A	1		T	H16	PR9A	3		T*	H16	PR11A	3		T*
H15	PR6B	1		C	H15	PR8D	2		C	H15	PR10D	2		C
G15	PR6A	1		T	G15	PR8C	2		T	G15	PR10C	2		T
H14	PR5D	1		C	H14	PR8B	2		C*	H14	PR10B	2		C*
G14	PR5C	1		T	G14	PR8A	2		T*	G14	PR10A	2		T*
GND	GNDIO1	1			GND	GNDIO2	2			GND	GNDIO2	2		
VCCIO1	VCCIO1	1			VCCIO2	VCCIO2	2			VCCIO2	VCCIO2	2		
H13	PR6D	1		C	H13	PR7D	2		C	H13	PR9D	2		C
H12	PR6C	1		T	H12	PR7C	2		T	H12	PR9C	2		T
G13	PR4D	1		C	G13	PR7B	2		C*	G13	PR9B	2		C*
G12	PR4C	1		T	G12	PR7A	2		T*	G12	PR9A	2		T*
G16	PR5B	1		C	G16	PR6D	2		C	G16	PR7D	2		C
F16	PR5A	1		T	F16	PR6C	2		T	F16	PR7C	2		T
F15	PR4B	1		C	F15	PR6B	2		C*	F15	PR7B	2		C*
E15	PR4A	1		T	E15	PR6A	2		T*	E15	PR7A	2		T*
E16	PR3B	1		C	E16	PR5D	2		C	E16	PR6D	2		C
D16	PR3A	1		T	D16	PR5C	2		T	D16	PR6C	2		T
VCCIO1	VCCIO1	1			VCCIO2	VCCIO2	2			VCCIO2	VCCIO2	2		
GND	GNDIO1	1			GND	GNDIO2	2			GND	GNDIO2	2		
D15	PR2D	1		C	D15	PR5B	2		C*	D15	PR6B	2		C*
C15	PR2C	1		T	C15	PR5A	2		T*	C15	PR6A	2		T*
C16	PR2B	1		C	C16	PR4D	2		C	C16	PR5D	2		C
B16	PR2A	1		T	B16	PR4C	2		T	B16	PR5C	2		T
F14	PR3D	1		C	F14	PR4B	2		C*	F14	PR5B	2		C*
E14	PR3C	1		T	E14	PR4A	2		T*	E14	PR5A	2		T*
-	-	-			-	-	-			GND	GND	-		
F12	NC				F12	PR3D	2		C	F12	PR4D	2		C
F13	NC				F13	PR3C	2		T	F13	PR4C	2		T
E12	NC				E12	PR3B	2		C*	E12	PR4B	2		C*
E13	NC				E13	PR3A	2		T*	E13	PR4A	2		T*
D13	NC				D13	PR2B	2		C	D13	PR3B	2		C*
D14	NC				D14	PR2A	2		T	D14	PR3A	2		T*
VCCIO0	VCCIO0	0			VCCIO2	VCCIO2	2			VCCIO2	VCCIO2	2		
GND	GNDIO0	0			GND	GNDIO2	2			GND	GNDIO2	2		
GND	GNDIO0	0			GND	GNDIO1	1			GND	GNDIO1	1		
VCCIO0	VCCIO0	0			VCCIO1	VCCIO1	1			VCCIO1	VCCIO1	1		
B15	NC				B15	PT11D	1		C	B15	PT16D	1		C
A15	NC				A15	PT11C	1		T	A15	PT16C	1		T
C14	NC				C14	PT11B	1		C	C14	PT16B	1		C
B14	NC				B14	PT11A	1		T	B14	PT16A	1		T
C13	PT9F	0		C	C13	PT10F	1		C	C13	PT15D	1		C
B13	PT9E	0		T	B13	PT10E	1		T	B13	PT15C	1		T

LCMXO2280 Logic Signal Connections: 324 ftBGA

LCMXO2280				
Ball Number	Ball Function	Bank	Dual Function	Differential
GND	GNDIO7	7		
VCCIO7	VCCIO7	7		
D4	PL2A	7	LUM0_PLLT_FB_A	T
F5	PL2B	7	LUM0_PLLC_FB_A	C
B3	PL3A	7		T*
C3	PL3B	7		C*
E4	PL3C	7	LUM0_PLLT_IN_A	T
G6	PL3D	7	LUM0_PLLC_IN_A	C
A1	PL4A	7		T*
B1	PL4B	7		C*
F4	PL4C	7		T
VCC	VCC	-		
E3	PL4D	7		C
D2	PL5A	7		T*
D3	PL5B	7		C*
G5	PL5C	7		T
F3	PL5D	7		C
C2	PL6A	7		T*
VCCIO7	VCCIO7	7		
GND	GNDIO7	7		
C1	PL6B	7		C*
H5	PL6C	7		T
G4	PL6D	7		C
E2	PL7A	7		T*
D1	PL7B	7	GSRN	C*
J6	PL7C	7		T
H4	PL7D	7		C
F2	PL8A	7		T*
E1	PL8B	7		C*
GND	GND	-		
J3	PL8C	7		T
J5	PL8D	7		C
G3	PL9A	7		T*
H3	PL9B	7		C*
K3	PL9C	7		T
K5	PL9D	7		C
F1	PL10A	7		T*
VCCIO7	VCCIO7	7		
GND	GNDIO7	7		
G1	PL10B	7		C*
K4	PL10C	7		T
K6	PL10D	7		C

LCMXO2280 Logic Signal Connections: 324 ftBGA (Cont.)

LCMXO2280				
Ball Number	Ball Function	Bank	Dual Function	Differential
GND	GNDIO3	3		
VCCIO3	VCCIO3	3		
P15	PR20B	3		C
N14	PR20A	3		T
N15	PR19B	3		C
M13	PR19A	3		T
R15	PR18B	3		C*
T16	PR18A	3		T*
N16	PR17D	3		C
M14	PR17C	3		T
U17	PR17B	3		C*
VCC	VCC	-		
U18	PR17A	3		T*
R17	PR16D	3		C
R16	PR16C	3		T
P16	PR16B	3		C*
VCCIO3	VCCIO3	3		
GND	GNDIO3	3		
P17	PR16A	3		T*
L13	PR15D	3		C
M15	PR15C	3		T
T17	PR15B	3		C*
T18	PR15A	3		T*
L14	PR14D	3		C
L15	PR14C	3		T
R18	PR14B	3		C*
P18	PR14A	3		T*
GND	GND	-		
K15	PR13D	3		C
K13	PR13C	3		T
N17	PR13B	3		C*
N18	PR13A	3		T*
K16	PR12D	3		C
K14	PR12C	3		T
M16	PR12B	3		C*
L16	PR12A	3		T*
GND	GNDIO3	3		
VCCIO3	VCCIO3	3		
J16	PR11D	3		C
J14	PR11C	3		T
M17	PR11B	3		C*
L17	PR11A	3		T*
J15	PR10D	2		C

Part Number	LUTs	Supply Voltage	I/Os	Grade	Package	Pins	Temp.
LCMXO2280C-3T100C	2280	1.8V/2.5V/3.3V	73	-3	TQFP	100	COM
LCMXO2280C-4T100C	2280	1.8V/2.5V/3.3V	73	-4	TQFP	100	COM
LCMXO2280C-5T100C	2280	1.8V/2.5V/3.3V	73	-5	TQFP	100	COM
LCMXO2280C-3T144C	2280	1.8V/2.5V/3.3V	113	-3	TQFP	144	COM
LCMXO2280C-4T144C	2280	1.8V/2.5V/3.3V	113	-4	TQFP	144	COM
LCMXO2280C-5T144C	2280	1.8V/2.5V/3.3V	113	-5	TQFP	144	COM
LCMXO2280C-3M132C	2280	1.8V/2.5V/3.3V	101	-3	csBGA	132	COM
LCMXO2280C-4M132C	2280	1.8V/2.5V/3.3V	101	-4	csBGA	132	COM
LCMXO2280C-5M132C	2280	1.8V/2.5V/3.3V	101	-5	csBGA	132	COM
LCMXO2280C-3B256C	2280	1.8V/2.5V/3.3V	211	-3	caBGA	256	COM
LCMXO2280C-4B256C	2280	1.8V/2.5V/3.3V	211	-4	caBGA	256	COM
LCMXO2280C-5B256C	2280	1.8V/2.5V/3.3V	211	-5	caBGA	256	COM
LCMXO2280C-3FT256C	2280	1.8V/2.5V/3.3V	211	-3	ftBGA	256	COM
LCMXO2280C-4FT256C	2280	1.8V/2.5V/3.3V	211	-4	ftBGA	256	COM
LCMXO2280C-5FT256C	2280	1.8V/2.5V/3.3V	211	-5	ftBGA	256	COM
LCMXO2280C-3FT324C	2280	1.8V/2.5V/3.3V	271	-3	ftBGA	324	COM
LCMXO2280C-4FT324C	2280	1.8V/2.5V/3.3V	271	-4	ftBGA	324	COM
LCMXO2280C-5FT324C	2280	1.8V/2.5V/3.3V	271	-5	ftBGA	324	COM

Part Number	LUTs	Supply Voltage	I/Os	Grade	Package	Pins	Temp.
LCMXO256E-3T100C	256	1.2V	78	-3	TQFP	100	COM
LCMXO256E-4T100C	256	1.2V	78	-4	TQFP	100	COM
LCMXO256E-5T100C	256	1.2V	78	-5	TQFP	100	COM
LCMXO256E-3M100C	256	1.2V	78	-3	csBGA	100	COM
LCMXO256E-4M100C	256	1.2V	78	-4	csBGA	100	COM
LCMXO256E-5M100C	256	1.2V	78	-5	csBGA	100	COM

Part Number	LUTs	Supply Voltage	I/Os	Grade	Package	Pins	Temp.
LCMXO640E-3T100C	640	1.2V	74	-3	TQFP	100	COM
LCMXO640E-4T100C	640	1.2V	74	-4	TQFP	100	COM
LCMXO640E-5T100C	640	1.2V	74	-5	TQFP	100	COM
LCMXO640E-3M100C	640	1.2V	74	-3	csBGA	100	COM
LCMXO640E-4M100C	640	1.2V	74	-4	csBGA	100	COM
LCMXO640E-5M100C	640	1.2V	74	-5	csBGA	100	COM
LCMXO640E-3T144C	640	1.2V	113	-3	TQFP	144	COM
LCMXO640E-4T144C	640	1.2V	113	-4	TQFP	144	COM
LCMXO640E-5T144C	640	1.2V	113	-5	TQFP	144	COM
LCMXO640E-3M132C	640	1.2V	101	-3	csBGA	132	COM
LCMXO640E-4M132C	640	1.2V	101	-4	csBGA	132	COM
LCMXO640E-5M132C	640	1.2V	101	-5	csBGA	132	COM
LCMXO640E-3B256C	640	1.2V	159	-3	caBGA	256	COM
LCMXO640E-4B256C	640	1.2V	159	-4	caBGA	256	COM
LCMXO640E-5B256C	640	1.2V	159	-5	caBGA	256	COM
LCMXO640E-3FT256C	640	1.2V	159	-3	ftBGA	256	COM
LCMXO640E-4FT256C	640	1.2V	159	-4	ftBGA	256	COM
LCMXO640E-5FT256C	640	1.2V	159	-5	ftBGA	256	COM

Part Number	LUTs	Supply Voltage	I/Os	Grade	Package	Pins	Temp.
LCMXO1200E-3T100C	1200	1.2V	73	-3	TQFP	100	COM
LCMXO1200E-4T100C	1200	1.2V	73	-4	TQFP	100	COM
LCMXO1200E-5T100C	1200	1.2V	73	-5	TQFP	100	COM
LCMXO1200E-3T144C	1200	1.2V	113	-3	TQFP	144	COM
LCMXO1200E-4T144C	1200	1.2V	113	-4	TQFP	144	COM
LCMXO1200E-5T144C	1200	1.2V	113	-5	TQFP	144	COM
LCMXO1200E-3M132C	1200	1.2V	101	-3	csBGA	132	COM
LCMXO1200E-4M132C	1200	1.2V	101	-4	csBGA	132	COM
LCMXO1200E-5M132C	1200	1.2V	101	-5	csBGA	132	COM
LCMXO1200E-3B256C	1200	1.2V	211	-3	caBGA	256	COM
LCMXO1200E-4B256C	1200	1.2V	211	-4	caBGA	256	COM
LCMXO1200E-5B256C	1200	1.2V	211	-5	caBGA	256	COM
LCMXO1200E-3FT256C	1200	1.2V	211	-3	ftBGA	256	COM
LCMXO1200E-4FT256C	1200	1.2V	211	-4	ftBGA	256	COM
LCMXO1200E-5FT256C	1200	1.2V	211	-5	ftBGA	256	COM

Part Number	LUTs	Supply Voltage	I/Os	Grade	Package	Pins	Temp.
LCMXO2280E-3T100C	2280	1.2V	73	-3	TQFP	100	COM
LCMXO2280E-4T100C	2280	1.2V	73	-4	TQFP	100	COM
LCMXO2280E-5T100C	2280	1.2V	73	-5	TQFP	100	COM
LCMXO2280E-3T144C	2280	1.2V	113	-3	TQFP	144	COM
LCMXO2280E-4T144C	2280	1.2V	113	-4	TQFP	144	COM
LCMXO2280E-5T144C	2280	1.2V	113	-5	TQFP	144	COM
LCMXO2280E-3M132C	2280	1.2V	101	-3	csBGA	132	COM
LCMXO2280E-4M132C	2280	1.2V	101	-4	csBGA	132	COM
LCMXO2280E-5M132C	2280	1.2V	101	-5	csBGA	132	COM
LCMXO2280E-3B256C	2280	1.2V	211	-3	caBGA	256	COM
LCMXO2280E-4B256C	2280	1.2V	211	-4	caBGA	256	COM
LCMXO2280E-5B256C	2280	1.2V	211	-5	caBGA	256	COM
LCMXO2280E-3FT256C	2280	1.2V	211	-3	ftBGA	256	COM
LCMXO2280E-4FT256C	2280	1.2V	211	-4	ftBGA	256	COM
LCMXO2280E-5FT256C	2280	1.2V	211	-5	ftBGA	256	COM
LCMXO2280E-3FT324C	2280	1.2V	271	-3	ftBGA	324	COM
LCMXO2280E-4FT324C	2280	1.2V	271	-4	ftBGA	324	COM
LCMXO2280E-5FT324C	2280	1.2V	271	-5	ftBGA	324	COM

Part Number	LUTs	Supply Voltage	I/Os	Grade	Package	Pins	Temp.
LCMXO256E-3TN100I	256	1.2V	78	-3	Lead-Free TQFP	100	IND
LCMXO256E-4TN100I	256	1.2V	78	-4	Lead-Free TQFP	100	IND
LCMXO256E-3MN100I	256	1.2V	78	-3	Lead-Free csBGA	100	IND
LCMXO256E-4MN100I	256	1.2V	78	-4	Lead-Free csBGA	100	IND

Part Number	LUTs	Supply Voltage	I/Os	Grade	Package	Pins	Temp.
LCMXO640E-3TN100I	640	1.2V	74	-3	Lead-Free TQFP	100	IND
LCMXO640E-4TN100I	640	1.2V	74	-4	Lead-Free TQFP	100	IND
LCMXO640E-3MN100I	640	1.2V	74	-3	Lead-Free csBGA	100	IND
LCMXO640E-4MN100I	640	1.2V	74	-4	Lead-Free csBGA	100	IND
LCMXO640E-3TN144I	640	1.2V	113	-3	Lead-Free TQFP	144	IND
LCMXO640E-4TN144I	640	1.2V	113	-4	Lead-Free TQFP	144	IND
LCMXO640E-3MN132I	640	1.2V	101	-3	Lead-Free csBGA	132	IND
LCMXO640E-4MN132I	640	1.2V	101	-4	Lead-Free csBGA	132	IND
LCMXO640E-3BN256I	640	1.2V	159	-3	Lead-Free caBGA	256	IND
LCMXO640E-4BN256I	640	1.2V	159	-4	Lead-Free caBGA	256	IND
LCMXO640E-3FTN256I	640	1.2V	159	-3	Lead-Free ftBGA	256	IND
LCMXO640E-4FTN256I	640	1.2V	159	-4	Lead-Free ftBGA	256	IND

Part Number	LUTs	Supply Voltage	I/Os	Grade	Package	Pins	Temp.
LCMXO1200E-3TN100I	1200	1.2V	73	-3	Lead-Free TQFP	100	IND
LCMXO1200E-4TN100I	1200	1.2V	73	-4	Lead-Free TQFP	100	IND
LCMXO1200E-3TN144I	1200	1.2V	113	-3	Lead-Free TQFP	144	IND
LCMXO1200E-4TN144I	1200	1.2V	113	-4	Lead-Free TQFP	144	IND
LCMXO1200E-3MN132I	1200	1.2V	101	-3	Lead-Free csBGA	132	IND
LCMXO1200E-4MN132I	1200	1.2V	101	-4	Lead-Free csBGA	132	IND
LCMXO1200E-3BN256I	1200	1.2V	211	-3	Lead-Free caBGA	256	IND
LCMXO1200E-4BN256I	1200	1.2V	211	-4	Lead-Free caBGA	256	IND
LCMXO1200E-3FTN256I	1200	1.2V	211	-3	Lead-Free ftBGA	256	IND
LCMXO1200E-4FTN256I	1200	1.2V	211	-4	Lead-Free ftBGA	256	IND

Part Number	LUTs	Supply Voltage	I/Os	Grade	Package	Pins	Temp.
LCMXO2280E-3TN100I	2280	1.2V	73	-3	Lead-Free TQFP	100	IND
LCMXO2280E-4TN100I	2280	1.2V	73	-4	Lead-Free TQFP	100	IND
LCMXO2280E-3TN144I	2280	1.2V	113	-3	Lead-Free TQFP	144	IND
LCMXO2280E-4TN144I	2280	1.2V	113	-4	Lead-Free TQFP	144	IND
LCMXO2280E-3MN132I	2280	1.2V	101	-3	Lead-Free csBGA	132	IND
LCMXO2280E-4MN132I	2280	1.2V	101	-4	Lead-Free csBGA	132	IND
LCMXO2280E-3BN256I	2280	1.2V	211	-3	Lead-Free caBGA	256	IND
LCMXO2280E-4BN256I	2280	1.2V	211	-4	Lead-Free caBGA	256	IND
LCMXO2280E-3FTN256I	2280	1.2V	211	-3	Lead-Free ftBGA	256	IND
LCMXO2280E-4FTN256I	2280	1.2V	211	-4	Lead-Free ftBGA	256	IND
LCMXO2280E-3FTN324I	2280	1.2V	271	-3	Lead-Free ftBGA	324	IND
LCMXO2280E-4FTN324I	2280	1.2V	271	-4	Lead-Free ftBGA	324	IND