

Welcome to [E-XFL.COM](https://www.e-xfl.com)

### What is "[Embedded - Microcontrollers](#)"?

"[Embedded - Microcontrollers](#)" refer to small, integrated circuits designed to perform specific tasks within larger systems. These microcontrollers are essentially compact computers on a single chip, containing a processor core, memory, and programmable input/output peripherals. They are called "embedded" because they are embedded within electronic devices to control various functions, rather than serving as standalone computers. Microcontrollers are crucial in modern electronics, providing the intelligence and control needed for a wide range of applications.

### Applications of "[Embedded - Microcontrollers](#)"

#### Details

Product Status	Active
Core Processor	HC08
Core Size	8-Bit
Speed	6MHz
Connectivity	SCI, USB
Peripherals	LED, LVD, POR, PWM
Number of I/O	21
Program Memory Size	12KB (12K x 8)
Program Memory Type	FLASH
EEPROM Size	-
RAM Size	384 x 8
Voltage - Supply (Vcc/Vdd)	4V ~ 5.5V
Data Converters	-
Oscillator Type	Internal
Operating Temperature	0°C ~ 70°C (TA)
Mounting Type	Surface Mount
Package / Case	28-SOIC (0.295", 7.50mm Width)
Supplier Device Package	28-SOIC
Purchase URL	<a href="https://www.e-xfl.com/pro/item?MUrl=&amp;PartUrl=mc68hc908jb12dw">https://www.e-xfl.com/pro/item?MUrl=&amp;PartUrl=mc68hc908jb12dw</a>

# Addendum to MC68HC908JB16 Technical Data

This addendum provides update and additional information to the  
*MC68HC908JB16 Technical Data*, Rev. 1.1  
(Freescale document number MC68HC908JB16/D).

pertaining to the following:

- MC68HC908JB16
  - Update to  $V_{REG}$  LVI trip point
  - 20-pin SOIC package
- MC68HC908JB12

---

## MC68HC908JB16

This section updates data sheet information and introduces the 20-pin SOIC package for the MC68HC908JB16. These updates apply to the 20-pin SOIC only.

**$V_{REG}$  LVI Trip Point**      Page 318, entry for minimum  $V_{REG}$  LVI trip point voltage has been updated.

*From:*

Characteristic	Symbol	Min	Typ	Max	Unit
$V_{REG}$ LVI trip point voltage	$V_{LVR}$	2.0	2.2	2.6	V

*To:*

$V_{REG}$ LVI trip point voltage	$V_{LVR}$	<b>1.9</b>	2.2	2.6	V
----------------------------------	-----------	------------	-----	-----	---

**Output Low Voltage** Page 318, entry for maximum  $V_{OL}$  has been updated.

*From:*

Characteristic	Symbol	Min	Typ	Max	Unit
Output low voltage ( $I_{Load} = 25\text{ mA}$ ) PTD0–PTD1 in ILDD mode	$V_{OL}$	—	—	0.5	V

*To:*

Output low voltage ( $I_{Load} = 45\text{ mA}$ ) PTD0/1 in ILDD mode	$V_{OL}$	—	—	0.5	V
---	----------	---	---	-----	---

**20-Pin SOIC**

*Order Number: MC68HC908JB16JDW*

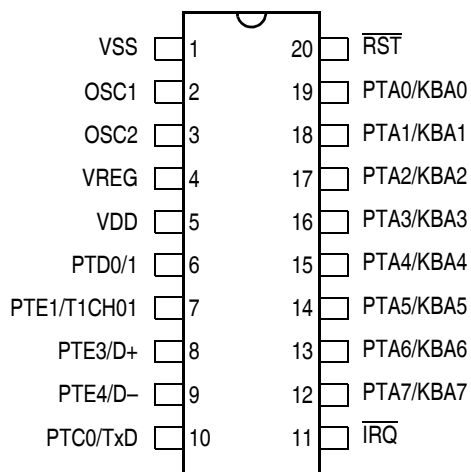

Pins not available on 20-pin package:		
PTC1/RxD	PTE0/TCLK	PTD2
	PTE2/T2CH01	PTD3
CGMXFC1	CGMXFC2	PTD4
CGMOUT1	CGMOUT2	PTD5
VREGA0	VREGA1	
VSSA0	VSSA1	VDDA

Internal pads are unconnected.

PTD0/1 pin: PTD0 and PTD1 internal pads are bonded together to PTD0/1 pin.  
 PTD0/1 has a 45 mA sink capability when configured as an output.  
 Pin direction must be configured such that DDRD0 = DDRD1.

**Figure 1. 20-Pin SOIC Pin Assignment**

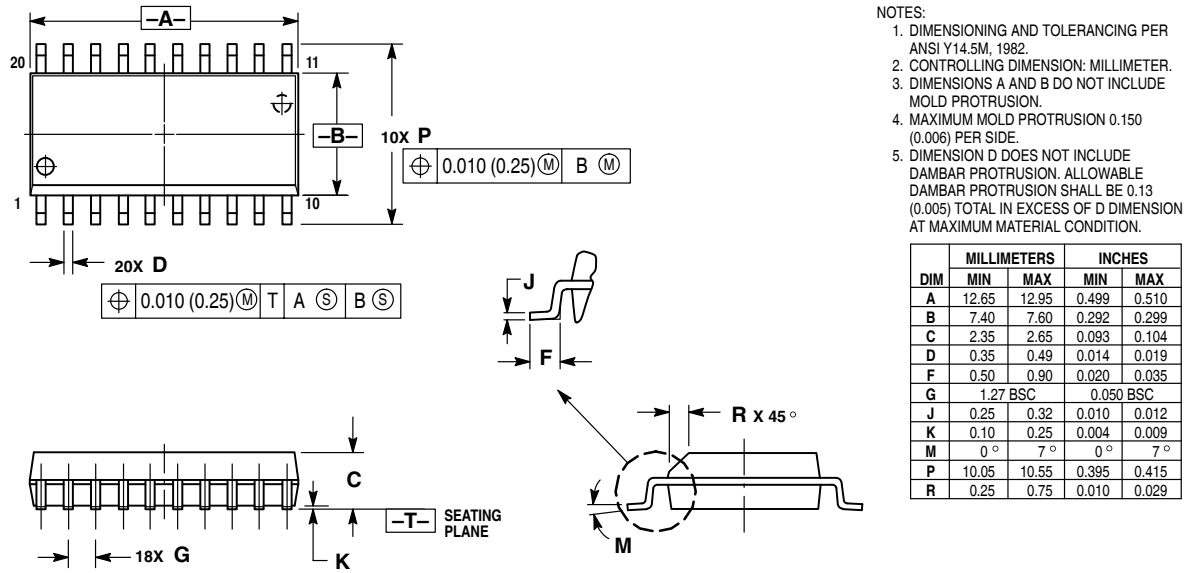

Figure 2. 20-Pin SOIC Mechanical Dimensions (Case No. 751D)

## MC68HC908JB12

This section introduces the MC68HC908JB12, a derivative of the MC68HC908JB16. The entire MC68HC908JB16 data book, including the updates in this addendum, applies to this device, with exceptions outlined below.

**Table 1. Summary of MC68HC908JB12 and MC68HC908JB16 Differences**

	MC68HC908JB12	MC68HC908JB16
<b>FLASH Memory</b>	12,288 bytes (\$CA00–\$F9FF)	16,384 bytes (\$BA00–\$F9FF)
<b>Dual Clock Generator Module</b>	Not implemented. \$0051–\$0059 unimplemented.	Yes
<b>Available Packages<sup>(1)</sup></b>	— 28-pin SOIC 20-pin SOIC	32-pin LQFP 28-pin SOIC 20-pin SOIC

1. The pin assignments are identical for both devices; see data sheet.

**MCU Block Diagram**     **Figure 3** shows the structure of the MC68HC908JB12.

**Memory Map**             **Figure 4** shows the memory map of the MC68HC908JB12.

**Dual Clock Generator Module**     The dual 27-MHz clock generator module on the MC68HC908JB16 is not designed in the MC68HC908JB12, hence, register locations from \$0051 to \$0059 are unimplemented. Information in the data book relating to the CGM do not apply to the MC68HC908JB12.

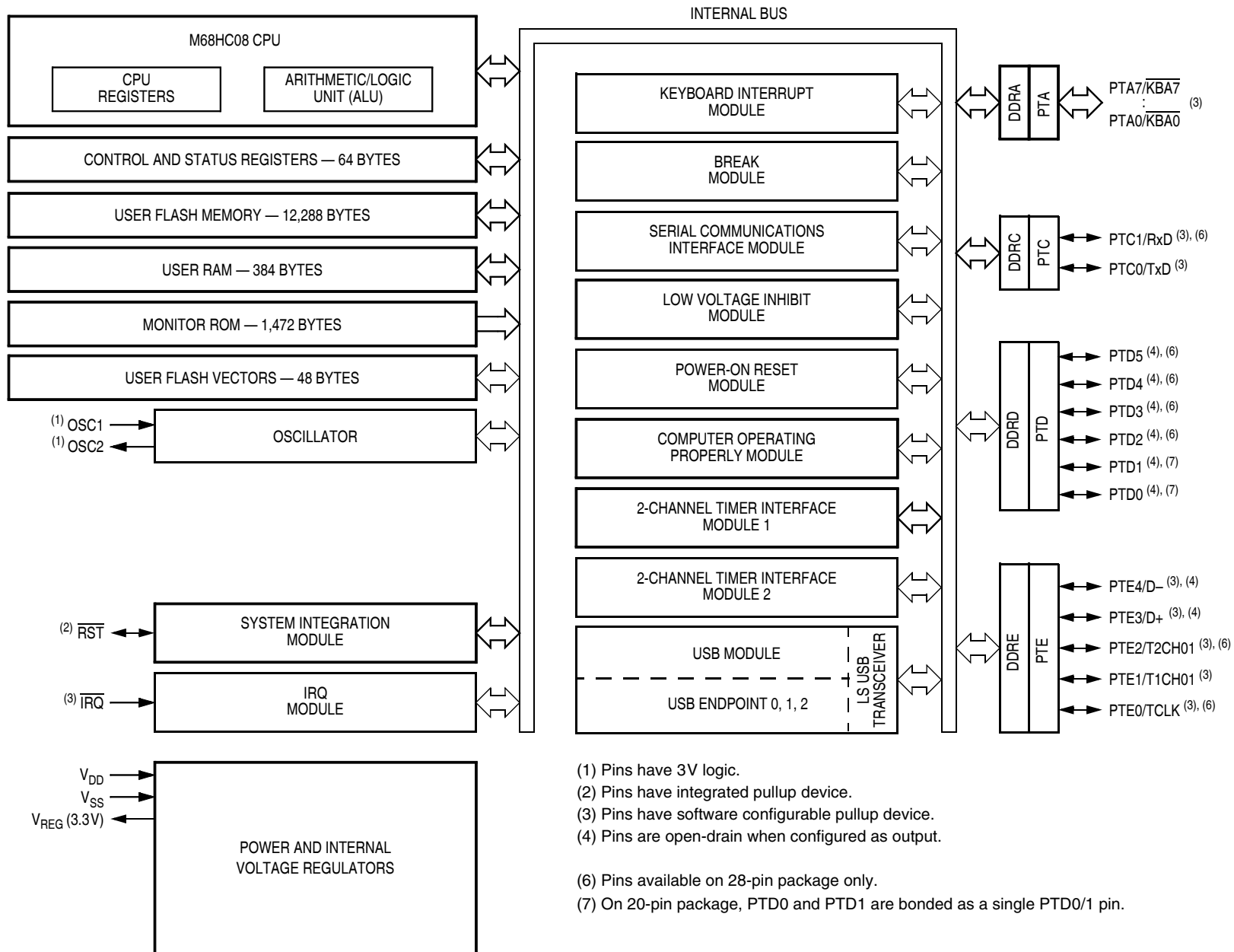

Figure 3. MC68HC908JB12 Block Diagram

\$0000 ↓ \$007F	I/O Registers 128 Bytes
\$0080 ↓ \$01FF	RAM 384 Bytes
\$0200 ↓ \$C9FF	Unimplemented 51,200 Bytes
\$CA00 ↓ \$F9FF	FLASH Memory 12,288 Bytes
\$FA00 ↓ \$FDFF	Monitor ROM 1 1,024 Bytes
\$FE00	SIM Break Status Register (SBSR)
\$FE01	SIM Reset Status Register (SRSR)
\$FE02	Reserved
\$FE03	SIM Break Flag Control Register (SBFCR)
\$FE04	Interrupt Status Register 1 (INT1)
\$FE05	Interrupt Status Register 2 (INT2)
\$FE06	Reserved
\$FE07	Reserved
\$FE08	FLASH Control Register (FLCR)
\$FE09	FLASH Block Protect Register (FLBPR)
\$FE0A	Reserved
\$FE0B	Reserved
\$FE0C	Break Address Register High (BRKH)
\$FE0D	Break Address Register Low (BRKL)
\$FE0E	Break Status and Control Register (BRKSCR)
\$FE0F	Reserved
\$FE10 ↓ \$FFCF	Monitor ROM 2 448 Bytes
\$FFD0 ↓ \$FFFF	FLASH Vectors 48 Bytes

Figure 4. MC68HC908JB12 Memory Map

**Pullup on PTE3/D+ and PTE4/D– Pins**

On the MC68HC908JB12, control over the pullup devices on PTE3/D+ and PTE4/D– pins are shown in [Table 2](#).

**Table 2. Pullup Control on PTE3/D+ and PTE4/D– Pins**

PULLEN (\$001A)	USBEN (\$0038)	PTE <sub>x</sub> P (\$001D)	PTE4IE (\$001C)	PTE3/D+ pin	PTE4/D– pin
0	0	0	0	—	—
0	0	1	0	5 kΩ pullup to V <sub>DD</sub>	5 kΩ pullup to V <sub>DD</sub>
0	0	0	1	—	5 kΩ pullup to V <sub>DD</sub> <sup>(1)</sup>
0	0	1	1	5 kΩ pullup to V <sub>DD</sub>	5 kΩ pullup to V <sub>DD</sub> <sup>(1)</sup>
0	1	X	X	—	—
1	1	X	X	—	1.5 kΩ pullup to V <sub>REG</sub>
1	0	X	0	—	1.5 kΩ pullup to V <sub>REG</sub>
1	0	X	1	Do not set this configuration.	

1. External interrupt function is also enabled on PTE4/D– pin.

**Electrical Specifications**

Electrical specifications for the MC68HC908JB16 apply to the MC68HC908JB12, except for the USB reset timing:

Bus State	Signaling Levels	
	Transmit	Receive
Reset	NA	D+ and D– < V <sub>IL</sub> (max) for ≥ 8 μs (MC68HC908JB16) D+ and D– < V <sub>IL</sub> (max) for ≥ 125 μs (MC68HC908JB12)

**Order Numbers**

These are MC order numbers for MC68HC908JB12.

**Table 3. MC68HC908JB12 Order Numbers**

MC Order Number	Package	Operating Temperature Range
MC68HC908JB12JDW	20-pin SOIC	0 °C to +70 °C
MC68HC908JB12DW	28-pin SOIC	0 °C to +70 °C



**How to Reach Us:****Home Page:**

[www.freescale.com](http://www.freescale.com)

**Web Support:**

<http://www.freescale.com/support>

**USA/Europe or Locations Not Listed:**

Freescale Semiconductor, Inc.  
Technical Information Center, EL516  
2100 East Elliot Road  
Tempe, Arizona 85284  
+1-800-521-6274 or +1-480-768-2130  
[www.freescale.com/support](http://www.freescale.com/support)

**Europe, Middle East, and Africa:**

Freescale Halbleiter Deutschland GmbH  
Technical Information Center  
Schatzbogen 7  
81829 Muenchen, Germany  
+44 1296 380 456 (English)  
+46 8 52200080 (English)  
+49 89 92103 559 (German)  
+33 1 69 35 48 48 (French)  
[www.freescale.com/support](http://www.freescale.com/support)

**Japan:**

Freescale Semiconductor Japan Ltd.  
Headquarters  
ARCO Tower 15F  
1-8-1, Shimo-Meguro, Meguro-ku,  
Tokyo 153-0064  
Japan  
0120 191014 or +81 3 5437 9125  
[support.japan@freescale.com](mailto:support.japan@freescale.com)

**Asia/Pacific:**

Freescale Semiconductor China Ltd.  
Exchange Building 23F  
No. 118 Jianguo Road  
Chaoyang District  
Beijing 100022  
China  
+86 10 5879 8000  
[support.asia@freescale.com](mailto:support.asia@freescale.com)

**For Literature Requests Only:**

Freescale Semiconductor Literature Distribution Center  
1-800-441-2447 or 303-675-2140  
Fax: 303-675-2150  
[LDCForFreescaleSemiconductor@hibbertgroup.com](mailto:LDCForFreescaleSemiconductor@hibbertgroup.com)

Information in this document is provided solely to enable system and software implementers to use Freescale Semiconductor products. There are no express or implied copyright licenses granted hereunder to design or fabricate any integrated circuits or integrated circuits based on the information in this document.

Freescale Semiconductor reserves the right to make changes without further notice to any products herein. Freescale Semiconductor makes no warranty, representation or guarantee regarding the suitability of its products for any particular purpose, nor does Freescale Semiconductor assume any liability arising out of the application or use of any product or circuit, and specifically disclaims any and all liability, including without limitation consequential or incidental damages. "Typical" parameters that may be provided in Freescale Semiconductor data sheets and/or specifications can and do vary in different applications and actual performance may vary over time. All operating parameters, including "Typicals", must be validated for each customer application by customer's technical experts. Freescale Semiconductor does not convey any license under its patent rights nor the rights of others. Freescale Semiconductor products are not designed, intended, or authorized for use as components in systems intended for surgical implant into the body, or other applications intended to support or sustain life, or for any other application in which the failure of the Freescale Semiconductor product could create a situation where personal injury or death may occur. Should Buyer purchase or use Freescale Semiconductor products for any such unintended or unauthorized application, Buyer shall indemnify and hold Freescale Semiconductor and its officers, employees, subsidiaries, affiliates, and distributors harmless against all claims, costs, damages, and expenses, and reasonable attorney fees arising out of, directly or indirectly, any claim of personal injury or death associated with such unintended or unauthorized use, even if such claim alleges that Freescale Semiconductor was negligent regarding the design or manufacture of the part.

RoHS-compliant and/or Pb-free versions of Freescale products have the functionality and electrical characteristics as their non-RoHS-compliant and/or non-Pb-free counterparts. For further information, see <http://www.freescale.com> or contact your Freescale sales representative.

For information on Freescale's Environmental Products program, go to <http://www.freescale.com/epp>.

Freescale™ and the Freescale logo are trademarks of Freescale Semiconductor, Inc. All other product or service names are the property of their respective owners.  
© Freescale Semiconductor, Inc. 2010. All rights reserved.