



Welcome to [E-XFL.COM](https://www.e-xfl.com)

Understanding [Embedded - FPGAs \(Field Programmable Gate Array\)](#)

Embedded - FPGAs, or Field Programmable Gate Arrays, are advanced integrated circuits that offer unparalleled flexibility and performance for digital systems. Unlike traditional fixed-function logic devices, FPGAs can be programmed and reprogrammed to execute a wide array of logical operations, enabling customized functionality tailored to specific applications. This reprogrammability allows developers to iterate designs quickly and implement complex functions without the need for custom hardware.

Applications of Embedded - FPGAs

The versatility of Embedded - FPGAs makes them indispensable in numerous fields. In telecommunications.

Details

Product Status	Obsolete
Number of LABs/CLBs	-
Number of Logic Elements/Cells	6100
Total RAM Bits	94208
Number of I/O	224
Number of Gates	-
Voltage - Supply	1.14V ~ 1.26V
Mounting Type	Surface Mount
Operating Temperature	-40°C ~ 100°C (TJ)
Package / Case	484-BBGA
Supplier Device Package	484-FPBGA (23x23)
Purchase URL	https://www.e-xfl.com/product-detail/lattice-semiconductor/lfecp6e-4fn484i

Features

■ Extensive Density and Package Options

- 1.5K to 32.8K LUT4s
- 65 to 496 I/Os
- Density migration supported

■ sysDSP™ Block (LatticeECP™ Versions)

- High performance multiply and accumulate
- 4 to 8 blocks
 - 4 to 8 36x36 multipliers or
 - 16 to 32 18x18 multipliers or
 - 32 to 64 9x9 multipliers

■ Embedded and Distributed Memory

- 18 Kbits to 498 Kbits sysMEM™ Embedded Block RAM (EBR)
- Up to 131 Kbits distributed RAM
- Flexible memory resources:
 - Distributed and block memory

■ Flexible I/O Buffer

- Programmable sysI/O™ buffer supports wide range of interfaces:

- LVCMOS 3.3/2.5/1.8/1.5/1.2
- LVTTTL
- SSTL 3/2 Class I, II, SSTL18 Class I
- HSTL 18 Class I, II, III, HSTL15 Class I, III
- PCI
- LVDS, Bus-LVDS, LVPECL, RSDS

■ Dedicated DDR Memory Support

- Implements interface up to DDR400 (200MHz)

■ sysCLOCK™ PLLs

- Up to four analog PLLs per device
- Clock multiply, divide and phase shifting

■ System Level Support

- IEEE Standard 1149.1 Boundary Scan, plus ispTRACY™ internal logic analyzer capability
- SPI boot flash interface
- 1.2V power supply

■ Low Cost FPGA

- Features optimized for mainstream applications
- Low cost TQFP and PQFP packaging

Table 1-1. LatticeECP/EC Family Selection Guide

Device	LFEC1	LFEC3	LFEC6/ LFCEP6	LFEC10/ LFCEP10	LFEC15/ LFCEP15	LFEC20/ LFCEP20	LFEC33/ LFCEP33
PFU/PFF Rows	12	16	24	32	40	44	64
PFU/PFF Columns	16	24	32	40	48	56	64
PFUs/PFFs	192	384	768	1280	1920	2464	4096
LUTs (K)	1.5	3.1	6.1	10.2	15.4	19.7	32.8
Distributed RAM (Kbits)	6	12	25	41	61	79	131
EBR SRAM (Kbits)	18	55	92	276	350	424	498
EBR SRAM Blocks	2	6	10	30	38	46	54
sysDSP Blocks ¹	—	—	4	5	6	7	8
18x18 Multipliers ¹	—	—	16	20	24	28	32
V _{CC} Voltage (V)	1.2	1.2	1.2	1.2	1.2	1.2	1.2
Number of PLLs	2	2	2	4	4	4	4
Packages and I/O Combinations:							
100-pin TQFP (14 x 14 mm)	67	67					
144-pin TQFP (20 x 20 mm)	97	97	97				
208-pin PQFP (28 x 28 mm)	112	145	147	147			
256-ball fpBGA (17 x 17 mm)		160	195	195	195		
484-ball fpBGA (23 x 23 mm)			224	288	352	360	360
672-ball fpBGA (27 x 27 mm)						400	496

1. LatticeECP devices only.

grammed during configuration or can be adjusted dynamically. In dynamic mode, the PLL may lose lock after adjustment and not relock until the t_{LOCK} parameter has been satisfied. Additionally, the phase and duty cycle block allows the user to adjust the phase and duty cycle of the CLKOS output.

The sysCLOCK PLLs provide the ability to synthesize clock frequencies. Each PLL has four dividers associated with it: input clock divider, feedback divider, post scalar divider and secondary clock divider. The input clock divider is used to divide the input clock signal, while the feedback divider is used to multiply the input clock signal. The post scalar divider allows the VCO to operate at higher frequencies than the clock output, thereby increasing the frequency range. The secondary divider is used to derive lower frequency outputs.

Figure 2-11. PLL Diagram

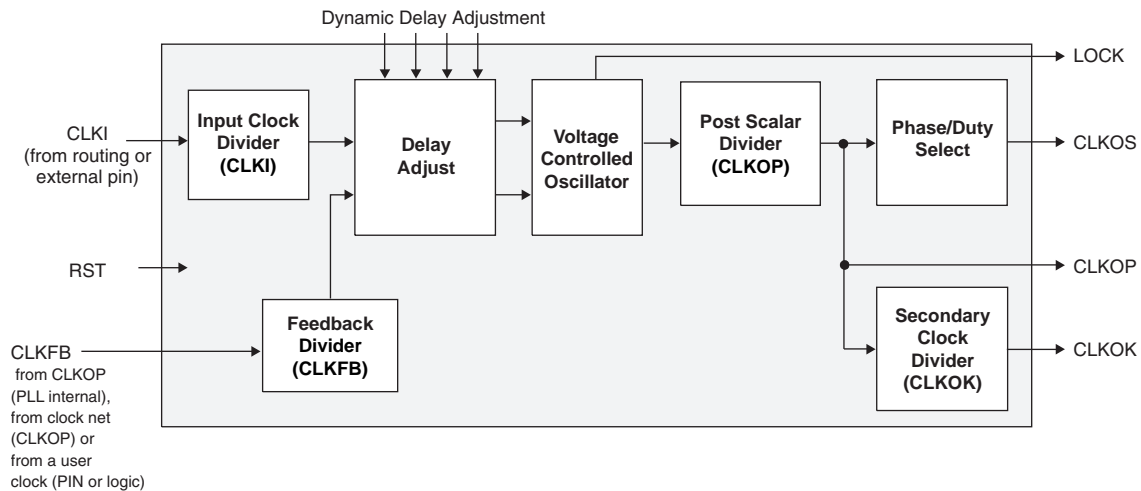
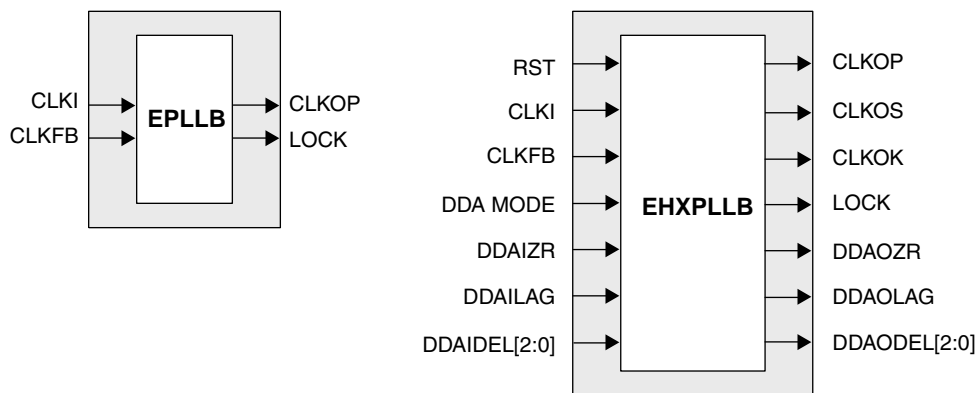

Figure 2-12 shows the available macros for the PLL. Table 2-5 provides signal description of the PLL Block.

Figure 2-12. PLL Primitive



decoders. These complex signal processing functions use similar building blocks such as multiply-adders and multiply-accumulators.

sysDSP Block Approach Compared to General DSP

Conventional general-purpose DSP chips typically contain one to four (Multiply and Accumulate) MAC units with fixed data-width multipliers; this leads to limited parallelism and limited throughput. Their throughput is increased by higher clock speeds. The LatticeECP, on the other hand, has many DSP blocks that support different data-widths. This allows the designer to use highly parallel implementations of DSP functions. The designer can optimize the DSP performance vs. area by choosing an appropriate level of parallelism. Figure 2-18 compares the serial and the parallel implementations.

Figure 2-18. Comparison of General DSP and LatticeECP-DSP Approaches

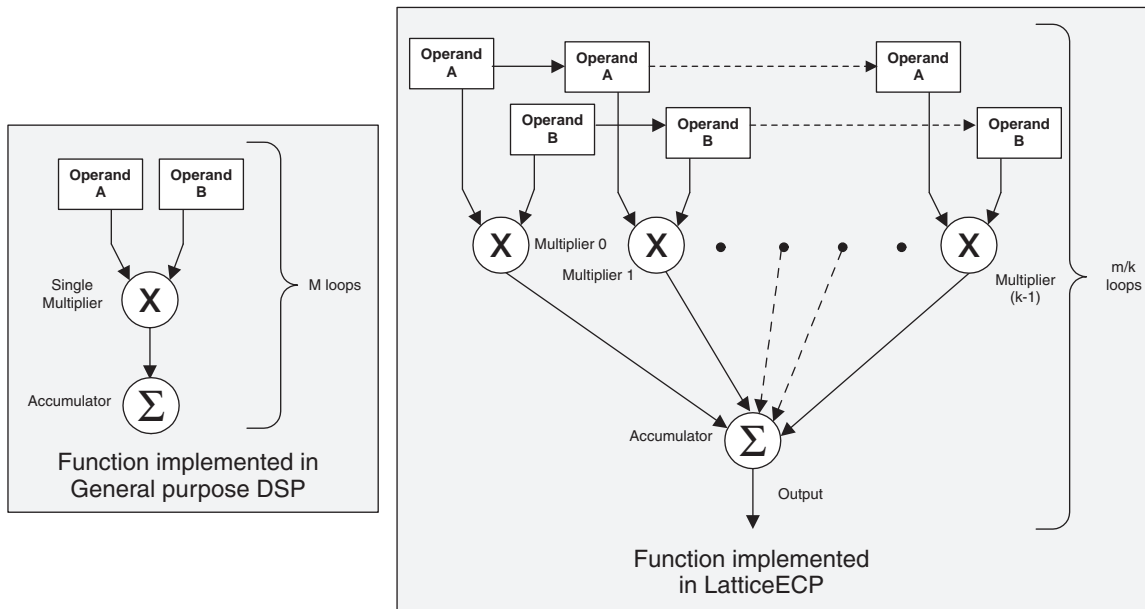

sysDSP Block Capabilities

The sysDSP block in the LatticeECP-DSP family supports four functional elements in three 9, 18 and 36 data path widths. The user selects a function element for a DSP block and then selects the width and type (signed/unsigned) of its operands. The operands in the LatticeECP-DSP family sysDSP Blocks can be either signed or unsigned but not mixed within a function element. Similarly, the operand widths cannot be mixed within a block.

The resources in each sysDSP block can be configured to support the following four elements:

- MULT (Multiply)
- MAC (Multiply, Accumulate)
- MULTADD (Multiply, Addition/Subtraction)
- MULTADDSUM (Multiply, Addition/Subtraction, Accumulate)

The number of elements available in each block depends on the width selected from the three available options x9, x18, and x36. A number of these elements are concatenated for highly parallel implementations of DSP functions. Table 2-1 shows the capabilities of the block.

Input Register Block

The input register block contains delay elements and registers that can be used to condition signals before they are passed to the device core. Figure 2-26 shows the diagram of the input register block.

Input signals are fed from the sysI/O buffer to the input register block (as signal DI). If desired the input signal can bypass the register and delay elements and be used directly as a combinatorial signal (INDD), a clock (INCK) and in selected blocks the input to the DQS delay block. If one of the bypass options is not chosen, the signal first passes through an optional delay block. This delay, if selected, reduces input-register hold-time requirement when using a global clock.

The input block allows two modes of operation. In the single data rate (SDR) the data is registered, by one of the registers in the single data rate sync register block, with the system clock. In the DDR Mode two registers are used to sample the data on the positive and negative edges of the DQS signal creating two data streams, D0 and D2. These two data streams are synchronized with the system clock before entering the core. Further discussion on this topic is in the DDR Memory section of this data sheet.

Figure 2-27 shows the input register waveforms for DDR operation and Figure 2-28 shows the design tool primitives. The SDR/SYNC registers have reset and clock enable available.

The signal DDRCLKPOL controls the polarity of the clock used in the synchronization registers. It ensures adequate timing when data is transferred from the DQS to system clock domain. For further discussion on this topic, see the DDR Memory section of this data sheet.

Figure 2-26. Input Register Diagram

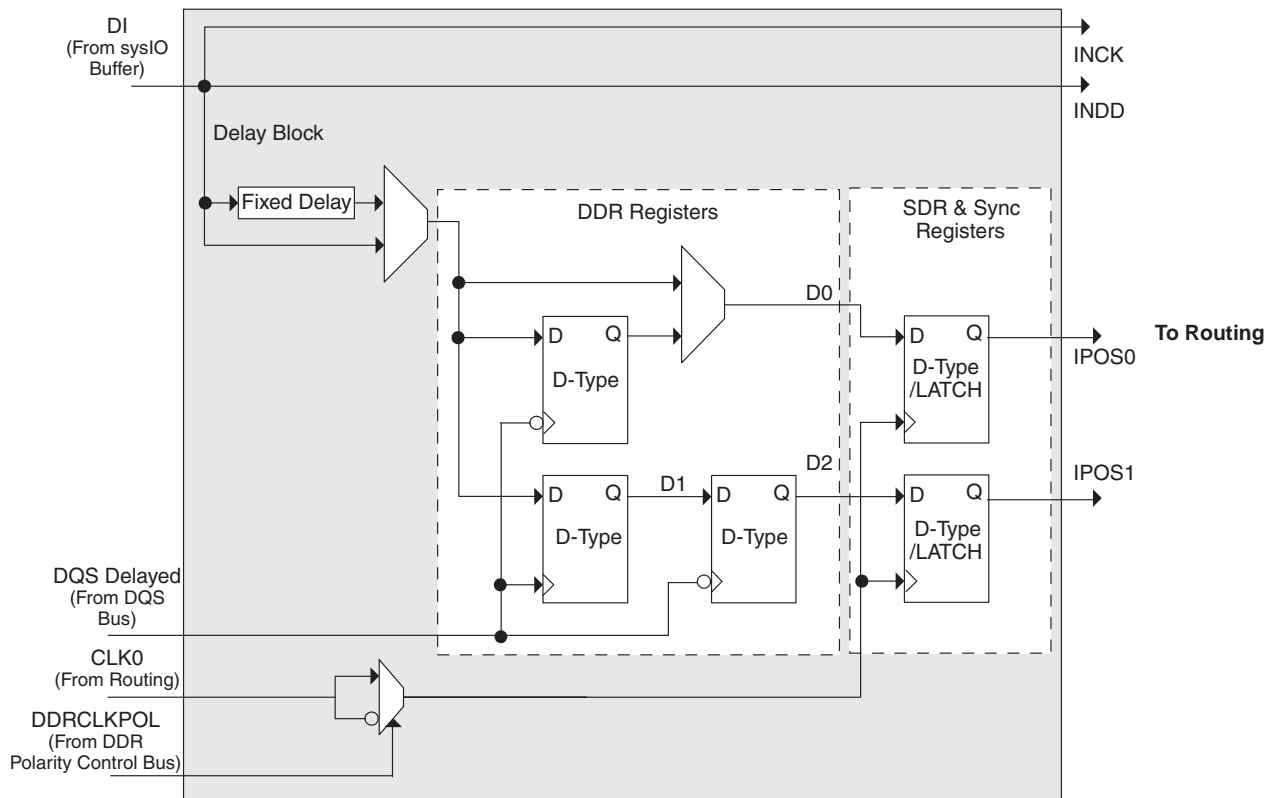
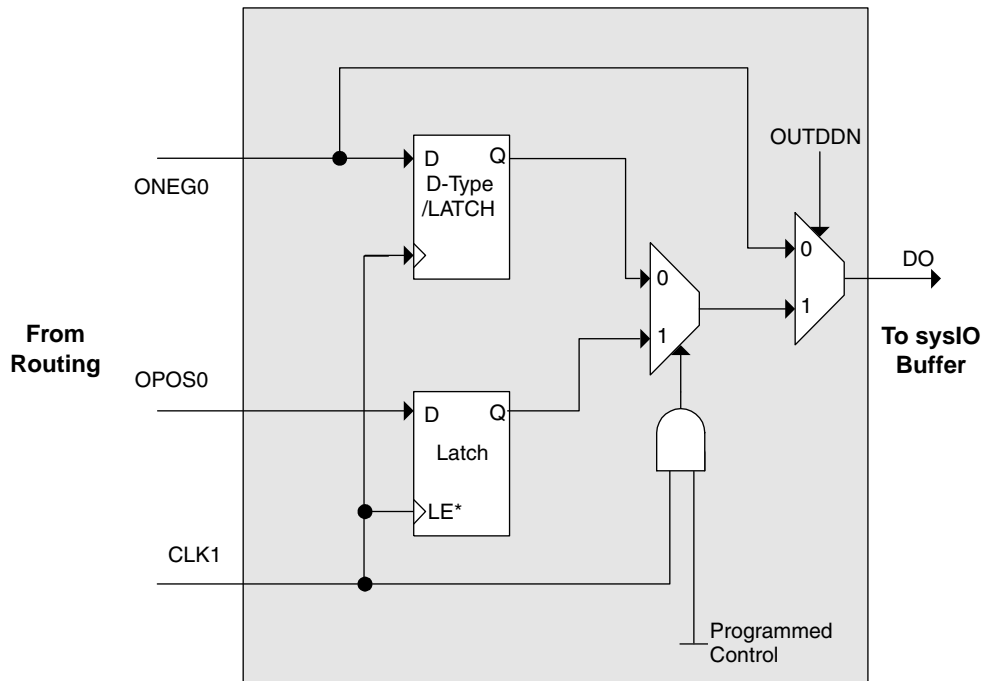
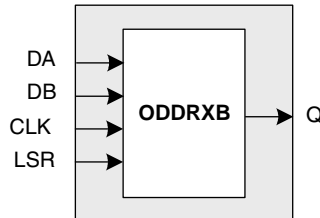

Figure 2-29. Output Register Block



*Latch is transparent when input is low.

Figure 2-30. ODDRXB Primitive



Tristate Register Block

The tristate register block provides the ability to register tri-state control signals from the core of the device before they are passed to the sysI/O buffers. The block contains a register for SDR operation and an additional latch for DDR operation. Figure 2-31 shows the diagram of the Tristate Register Block.

In SDR mode, ONEG1 feeds one of the flip-flops that then feeds the output. The flip-flop can be configured a D-type or latch. In DDR mode, ONEG1 is fed into one register on the positive edge of the clock and OPOS1 is latched. A multiplexer running off the same clock selects the correct register for feeding to the output (D0).

sysI/O Differential Electrical Characteristics
LVDS
Over Recommended Operating Conditions

Parameter Symbol	Parameter Description	Test Conditions	Min.	Typ.	Max.	Units
V_{INP}, V_{INM}	Input voltage		0	—	2.4	V
V_{THD}	Differential input threshold		+/-100	—	—	mV
V_{CM}	Input common mode voltage	100mV δV_{THD}	$V_{THD}/2$	1.2	1.8	V
		200mV δV_{THD}	$V_{THD}/2$	1.2	1.9	V
		350mV δV_{THD}	$V_{THD}/2$	1.2	2.0	V
I_{IN}	Input current	Power on or power off	—	—	+/-10	μ A
V_{OH}	Output high voltage for V_{OP} or V_{OM}	$R_T = 100$ Ohm	—	1.38	1.60	V
V_{OL}	Output low voltage for V_{OP} or V_{OM}	$R_T = 100$ Ohm	0.9V	1.03	—	V
V_{OD}	Output voltage differential	$(V_{OP} - V_{OM}), R_T = 100$ Ohm	250	350	450	mV
ΔV_{OD}	Change in V_{OD} between high and low		—	—	50	mV
V_{OS}	Output voltage offset	$(V_{OP} + V_{OM})/2, R_T = 100$ Ohm	1.125	1.25	1.375	V
ΔV_{OS}	Change in V_{OS} between H and L		—	—	50	mV
I_{OSD}	Output short circuit current	$V_{OD} = 0V$ Driver outputs shorted	—	—	6	mA

sysCLOCK PLL Timing

Over Recommended Operating Conditions

Parameter	Description	Conditions	Min.	Typ.	Max.	Units
f_{IN}	Input Clock Frequency (CLKI, CLKFB)		25	—	420	MHz
f_{OUT}	Output Clock Frequency (CLKOP, CLKOS)		25	—	420	MHz
f_{OUT2}	K-Divider Output Frequency (CLKOK)		0.195	—	210	MHz
f_{VCO}	PLL VCO Frequency		420	—	840	MHz
f_{PFD}	Phase Detector Input Frequency		25	—	—	MHz
AC Characteristics						
t_{DT}	Output Clock Duty Cycle	Default Duty Cycle Elected ³	45	50	55	%
t_{PH}^4	Output Phase Accuracy		—	—	0.05	UI
t_{OPJIT}^1	Output Clock Period Jitter	$f_{OUT} \geq 100\text{MHz}$	—	—	+/- 125	ps
		$f_{OUT} < 100\text{MHz}$	—	—	0.02	UIPP
t_{SK}	Input Clock to Output Clock Skew	Divider ratio = integer	—	—	+/- 200	ps
t_W	Output Clock Pulse Width	At 90% or 10% ³	1	—	—	ns
t_{LOCK}^2	PLL Lock-in Time		—	—	150	μs
t_{PA}	Programmable Delay Unit		100	250	450	ps
t_{IPJIT}	Input Clock Period Jitter		—	—	+/- 200	ps
t_{FBKDLY}	External Feedback Delay		—	—	10	ns
t_{HI}	Input Clock High Time	90% to 90%	0.5	—	—	ns
t_{LO}	Input Clock Low Time	10% to 10%	0.5	—	—	ns
t_{RST}	RST Pulse Width		10	—	—	ns

1. Jitter sample is taken over 10,000 samples of the primary PLL output with clean reference clock.

2. Output clock is valid after t_{LOCK} for PLL reset and dynamic delay adjustment.

3. Using LVDS output buffers.

4. Relative to CLKOP.

Timing v.G 0.30

Pin Information Summary (Cont.)

Pin Type		LFEC/EC15		LFEC/EC20		LFEC/EC33	
		256-fpBGA	484-fpBGA	484-fpBGA	672-fpBGA	484-fpBGA	672-fpBGA
Single Ended User I/O		195	352	360	400	360	496
Differential Pair User I/O		97	176	180	200	180	248
Configuration	Dedicated	13	13	13	13	13	13
	Muxed	56	56	56	56	56	56
TAP		5	5	5	5	5	5
Dedicated (total without supplies)		208	373	373	509	373	509
V _{CC}		10	20	20	32	16	28
V _{CCAUX}		2	12	12	20	12	20
V _{CCPLL}		0	0	0	0	4	4
V _{CCIO}	Bank0	2	4	4	6	4	6
	Bank1	2	4	4	6	4	6
	Bank2	2	4	4	6	4	6
	Bank3	2	4	4	6	4	6
	Bank4	2	4	4	6	4	6
	Bank5	2	4	4	6	4	6
	Bank6	2	4	4	6	4	6
	Bank7	2	4	4	6	4	6
GND, GND0-GND7		20	44	44	63	44	63
NC		0	11	3	96	3	0
Single Ended/ Differential I/O Pair per Bank	Bank0	32/16	48/24	48/24	64/32	48/24	64/32
	Bank1	18/9	48/24	48/24	48/24	48/24	64/32
	Bank2	16/8	40/20	40/20	40/20	40/20	56/28
	Bank3	32/16	40/20	44/22	48/24	44/22	64/32
	Bank4	17/8	48/24	48/24	48/24	48/24	64/32
	Bank5	32/16	48/24	48/24	64/32	48/24	64/32
	Bank6	32/16	40/20	44/22	48/24	44/22	64/32
	Bank7	16/8	40/20	40/20	40/20	40/20	56/28
V _{CCJ}		1	1	1	1	1	1

Note: During configuration the user-programmable I/Os are tri-stated with an internal pull-up resistor enabled. If any pin is not used (or not bonded to a package pin), it is also tri-stated with an internal pull-up resistor enabled after configuration.

LFEC1, LFEC3, LFEC6/EC6 Logic Signal Connections: 144 TQFP (Cont.)

Pin Number	LFEC1				LFEC3				LFEC6/EC6			
	Pin Function	Bank	LVD S	Dual Function	Pin Function	Bank	LVD S	Dual Function	Pin Function	Bank	LVD S	Dual Function
50	PB8B	5	C	VREF1_5	PB16B	5	C	VREF1_5	PB16B	5	C	VREF1_5
51	PB9A	5	T	PCLKT5_0	PB17A	5	T	PCLKT5_0	PB17A	5	T	PCLKT5_0
52	GND5	5			GND5	5			GND5	5		
53	PB9B	5	C	PCLKC5_0	PB17B	5	C	PCLKC5_0	PB17B	5	C	PCLKC5_0
54	VCCAUX	-			VCCAUX	-			VCCAUX	-		
55	VCCIO4	4			VCCIO4	4			VCCIO4	4		
56	PB10A	4	T	WRITEN	PB18A	4	T	WRITEN	PB18A	4	T	WRITEN
57	PB10B	4	C	CS1N	PB18B	4	C	CS1N	PB18B	4	C	CS1N
58	PB11A	4	T	VREF1_4	PB19A	4	T	VREF1_4	PB19A	4	T	VREF1_4
59	PB11B	4	C	CSN	PB19B	4	C	CSN	PB19B	4	C	CSN
60	PB12A	4	T	VREF2_4	PB20A	4	T	VREF2_4	PB20A	4	T	VREF2_4
61	PB12B	4	C	D0/SPID7	PB20B	4	C	D0/SPID7	PB20B	4	C	D0/SPID7
62	PB13A	4	T	D2/SPID5	PB21A	4	T	D2/SPID5	PB21A	4	T	D2/SPID5
63	GND4	4			GND4	4			GND4	4		
64	PB13B	4	C	D1/SPID6	PB21B	4	C	D1/SPID6	PB21B	4	C	D1/SPID6
65	PB14A	4	T	BDQS14	PB22A	4	T	BDQS22	PB22A	4	T	BDQS22
66	PB14B	4	C	D3/SPID4	PB22B	4	C	D3/SPID4	PB22B	4	C	D3/SPID4
67	PB15A	4	T		PB23A	4	T		PB23A	4	T	
68	PB15B	4	C	D4/SPID3	PB23B	4	C	D4/SPID3	PB23B	4	C	D4/SPID3
69	PB16B	4		D5/SPID2	PB24B	4		D5/SPID2	PB24B	4		D5/SPID2
70	PB17B	4		D6/SPID1	PB25B	4		D6/SPID1	PB25B	4		D6/SPID1
71	VCCIO4	4			VCCIO4	4			VCCIO4	4		
72*	GND3 GND4	-			GND3 GND4	-			GND3 GND4	-		
73	VCCIO3	3			VCCIO3	3			VCCIO3	3		
74	PR14A	3		VREF1_3	PR18A	3		VREF1_3	PR27A	3		VREF1_3
75	PR12B	3	C		PR16B	3	C		PR25B	3	C	
76	PR12A	3	T		PR16A	3	T		PR25A	3	T	
77	PR11B	3	C		PR15B	3	C		PR24B	3	C	
78	PR11A	3	T	RDQS11	PR15A	3	T	RDQS15	PR24A	3	T	RDQS24
79	PR10B	3	C	RLM0_PLLC_FB_A	PR14B	3	C	RLM0_PLLC_FB_A	PR23B	3	C	RLM0_PLLC_FB_A
80	GND3	3			GND3	3			GND3	3		
81	PR10A	3	T	RLM0_PLLT_FB_A	PR14A	3	T	RLM0_PLLT_FB_A	PR23A	3	T	RLM0_PLLT_FB_A
82	PR9B	3	C	RLM0_PLLC_IN_A	PR13B	3	C	RLM0_PLLC_IN_A	PR22B	3	C	RLM0_PLLC_IN_A
83	PR9A	3	T	RLM0_PLLT_IN_A	PR13A	3	T	RLM0_PLLT_IN_A	PR22A	3	T	RLM0_PLLT_IN_A
84	VCCIO3	3			VCCIO3	3			VCCIO3	3		
85	PR8B	3	C	DI/CSSPIN	PR12B	3	C	DI/CSSPIN	PR21B	3	C	DI/CSSPIN
86	PR8A	3	T	DOUT/CSON	PR12A	3	T	DOUT/CSON	PR21A	3	T	DOUT/CSON
87	PR7B	3	C	BUSY/SISPI	PR11B	3	C	BUSY/SISPI	PR20B	3	C	BUSY/SISPI
88	PR7A	3	T	D7/SPID0	PR11A	3	T	D7/SPID0	PR20A	3	T	D7/SPID0
89	CFG2	3			CFG2	3			CFG2	3		
90	CFG1	3			CFG1	3			CFG1	3		
91	CFG0	3			CFG0	3			CFG0	3		
92	VCC	-			VCC	-			VCC	-		
93	PROGRAMN	3			PROGRAMN	3			PROGRAMN	3		
94	CCLK	3			CCLK	3			CCLK	3		
95	INITN	3			INITN	3			INITN	3		
96	GND	-			GND	-			GND	-		
97	DONE	3			DONE	3			DONE	3		
98	GND	-			GND	-			GND	-		

LFEC1, LFEC3, LFEC6/EC6 Logic Signal Connections: 144 TQFP (Cont.)

Pin Number	LFEC1				LFEC3				LFEC6/EC6			
	Pin Function	Bank	LVD S	Dual Function	Pin Function	Bank	LVD S	Dual Function	Pin Function	Bank	LVD S	Dual Function
99	VCC	-			VCC	-			VCC	-		
100	PR5B	2	C	PCLKC2_0	PR9B	2	C	PCLKC2_0	PR9B	2	C	PCLKC2_0
101	PR5A	2	T	PCLKT2_0	PR9A	2	T	PCLKT2_0	PR9A	2	T	PCLKT2_0
102	PR4B	2	C		PR8B	2	C		PR8B	2	C	
103	PR4A	2	T		PR8A	2	T		PR8A	2	T	
104	PR3B	2	C		PR7B	2	C		PR7B	2	C	
105	PR3A	2	T		PR7A	2	T		PR7A	2	T	
106	PR2B	2	C	VREF1_2	PR2B	2	C	VREF1_2	PR2B	2	C	VREF1_2
107	PR2A	2	T	VREF2_2	PR2A	2	T	VREF2_2	PR2A	2	T	VREF2_2
108	VCCIO2	2			VCCIO2	2			VCCIO2	2		
109*	GND1 GND2	-			GND1 GND2	-			GND1 GND2	-		
110	VCCIO1	1			VCCIO1	1			VCCIO1	1		
111	PT17B	1	C		PT25B	1	C		PT25B	1	C	
112	PT17A	1	T		PT25A	1	T		PT25A	1	T	
113	PT15A	1			PT23A	1			PT23A	1		
114	PT14B	1	C		PT22B	1	C		PT22B	1	C	
115	PT14A	1	T	TDQS14	PT22A	1	T	TDQS22	PT22A	1	T	TDQS22
116	PT13B	1	C		PT21B	1	C		PT21B	1	C	
117	GND1	1			GND1	1			GND1	1		
118	PT13A	1	T		PT21A	1	T		PT21A	1	T	
119	PT12B	1	C		PT20B	1	C		PT20B	1	C	
120	PT12A	1	T		PT20A	1	T		PT20A	1	T	
121	PT11B	1	C	VREF2_1	PT19B	1	C	VREF2_1	PT19B	1	C	VREF2_1
122	PT11A	1	T	VREF1_1	PT19A	1	T	VREF1_1	PT19A	1	T	VREF1_1
123	PT10B	1	C		PT18B	1	C		PT18B	1	C	
124	PT10A	1	T		PT18A	1	T		PT18A	1	T	
125	VCCIO1	1			VCCIO1	1			VCCIO1	1		
126	VCCAUX	-			VCCAUX	-			VCCAUX	-		
127	PT9B	0	C	PCLKC0_0	PT17B	0	C	PCLKC0_0	PT17B	0	C	PCLKC0_0
128	GND0	0			GND0	0			GND0	0		
129	PT9A	0	T	PCLKT0_0	PT17A	0	T	PCLKT0_0	PT17A	0	T	PCLKT0_0
130	PT8B	0	C	VREF1_0	PT16B	0	C	VREF1_0	PT16B	0	C	VREF1_0
131	PT8A	0	T	VREF2_0	PT16A	0	T	VREF2_0	PT16A	0	T	VREF2_0
132	PT7B	0	C		PT15B	0	C		PT15B	0	C	
133	PT7A	0	T		PT15A	0	T		PT15A	0	T	
134	PT6B	0	C		PT14B	0	C		PT14B	0	C	
135	PT6A	0	T	TDQS6	PT14A	0	T	TDQS14	PT14A	0	T	TDQS14
136	VCCIO0	0			VCCIO0	0			VCCIO0	0		
137	PT5B	0	C		PT13B	0	C		PT13B	0	C	
138	PT5A	0	T		PT13A	0	T		PT13A	0	T	
139	PT4B	0	C		PT12B	0	C		PT12B	0	C	
140	PT4A	0	T		PT12A	0	T		PT12A	0	T	
141	PT2B	0	C		PT10B	0	C		PT10B	0	C	
142	PT2A	0	T		PT10A	0	T		PT10A	0	T	
143	VCCIO0	0			VCCIO0	0			VCCIO0	0		
144*	GND0 GND7	-			GND0 GND7	-			GND0 GND7	-		

*Double bonded to the pin.

LFEC6/EC6, LFEC6/EC10 Logic Signal Connections: 208 PQFP (Cont.)

Pin Number	LFEC6/LFEC6				LFEC10/LFEC10			
	Pin Function	Bank	LVDS	Dual Function	Pin Function	Bank	LVDS	Dual Function
43	PL24A	6	T	LDQS24	PL33A	6	T	LDQS33
44	PL24B	6	C		PL33B	6	C	
45	PL25A	6	T		PL34A	6	T	
46	PL25B	6	C		PL34B	6	C	
47	PL26A	6	T		PL35A	6	T	
48	PL26B	6	C		PL35B	6	C	
49	PL27A	6	T	VREF1_6	PL36A	6	T	VREF1_6
50	PL27B	6	C	VREF2_6	PL36B	6	C	VREF2_6
51	VCCIO6	6			VCCIO6	6		
52*	GND5 GND6	-			GND5 GND6	-		
53	VCCIO5	5			VCCIO5	5		
54	PB2A	5	T		PB2A	5	T	
55	PB2B	5	C		PB2B	5	C	
56	PB3A	5	T		PB3A	5	T	
57	PB3B	5	C		PB3B	5	C	
58	PB4A	5	T		PB4A	5	T	
59	PB4B	5	C		PB4B	5	C	
60	PB5A	5	T		PB5A	5	T	
61	PB5B	5	C		PB5B	5	C	
62	PB6A	5	T	BDQS6	PB6A	5	T	BDQS6
63	PB6B	5	C		PB6B	5	C	
64	VCCIO5	5			VCCIO5	5		
65	PB10A	5	T		PB18A	5	T	
66	PB10B	5	C		PB18B	5	C	
67	PB11A	5	T		PB19A	5	T	
68	PB11B	5	C		PB19B	5	C	
69	PB12A	5	T		PB20A	5	T	
70	PB12B	5	C		PB20B	5	C	
71	PB13A	5	T		PB21A	5	T	
72	GND5	5			GND5	5		
73	PB13B	5	C		PB21B	5	C	
74	VCCIO5	5			VCCIO5	5		
75	PB14A	5	T	BDQS14	PB22A	5	T	BDQS22
76	PB14B	5	C		PB22B	5	C	
77	PB15A	5	T		PB23A	5	T	
78	PB15B	5	C		PB23B	5	C	
79	PB16A	5	T	VREF2_5	PB24A	5	T	VREF2_5
80	PB16B	5	C	VREF1_5	PB24B	5	C	VREF1_5
81	PB17A	5	T	PCLKT5_0	PB25A	5	T	PCLKT5_0
82	GND5	5			GND5	5		
83	PB17B	5	C	PCLKC5_0	PB25B	5	C	PCLKC5_0
84	VCCAUX	-			VCCAUX	-		

LFECP/EC20 and LFECP/EC33 Logic Signal Connections: 484 fpBGA (Cont.)

LFECP20/LFEC20					LFECP/LFEC33				
Ball Number	Ball Function	Bank	LVD S	Dual Function	Ball Number	Ball Function	Bank	LVD S	Dual Function
C22	PR9A	2	T	RUM0_PLLT_FB_A	C22	PR17A	2	T	RUM0_PLLT_FB_A
G19	PR8B	2	C	RUM0_PLLC_IN_A	G19	PR16B	2	C	RUM0_PLLC_IN_A
G18	PR8A	2	T	RUM0_PLLT_IN_A	G18	PR16A	2	T	RUM0_PLLT_IN_A
F20	PR7B	2	C		F20	PR15B	2	C	
F19	PR7A	2	T		F19	PR15A	2	T	
E20	PR6B	2	C		E20	PR14B	2	C	
D20	PR6A	2	T	RDQS6	D20	PR14A	2	T	RDQS14
C21	PR5B	2	C		C21	PR13B	2	C	
GND	-	-			GND	GND2	2		
C20	PR5A	2	T		C20	PR13A	2	T	
F18	PR4B	2	C		F18	PR12B	2	C	
E18	PR4A	2	T		E18	PR12A	2	T	
B22	PR3B	2	C		B22	PR11B	2	C	
B21	PR3A	2	T		B21	PR11A	2	T	
GND	-	-			GND	GND2	2		
E19	PR2B	2	C	VREF1_2	E19	PR2B	2	C	VREF1_2
D19	PR2A	2	T	VREF2_2	D19	PR2A	2	T	VREF2_2
GND	GND2	2			GND	GND2	2		
GND	GND1	1			GND	GND1	1		
GND	-	-			GND	GND1	1		
G17	PT57B	1	C		G17	PT57B	1	C	
GND	-	-			GND	GND1	1		
F17	PT57A	1	T		F17	PT57A	1	T	
D18	PT56B	1	C		D18	PT56B	1	C	
C18	PT56A	1	T		C18	PT56A	1	T	
C19	PT55B	1	C		C19	PT55B	1	C	
B20	PT55A	1	T		B20	PT55A	1	T	
D17	PT54B	1	C		D17	PT54B	1	C	
C16	PT54A	1	T	TDQS54	C16	PT54A	1	T	TDQS54
B19	PT53B	1	C		B19	PT53B	1	C	
GND	GND1	1			GND	GND1	1		
A20	PT53A	1	T		A20	PT53A	1	T	
E17	PT52B	1	C		E17	PT52B	1	C	
C17	PT52A	1	T		C17	PT52A	1	T	
F16	PT51B	1	C		F16	PT51B	1	C	
E16	PT51A	1	T		E16	PT51A	1	T	
F15	PT50B	1	C		F15	PT50B	1	C	
D16	PT50A	1	T		D16	PT50A	1	T	
B18	PT49B	1	C		B18	PT49B	1	C	
GND	GND1	1			GND	GND1	1		
A19	PT49A	1	T		A19	PT49A	1	T	
B17	PT48B	1	C		B17	PT48B	1	C	
A18	PT48A	1	T		A18	PT48A	1	T	
B16	PT47B	1	C		B16	PT47B	1	C	

LFECP/EC20 and LFECP/EC33 Logic Signal Connections: 484 fpBGA (Cont.)

LFECP20/LFEC20					LFECP/LFEC33				
Ball Number	Ball Function	Bank	LVD S	Dual Function	Ball Number	Ball Function	Bank	LVD S	Dual Function
A7	PT27B	0	C		A7	PT27B	0	C	
A6	PT27A	0	T		A6	PT27A	0	T	
B7	PT26B	0	C		B7	PT26B	0	C	
B8	PT26A	0	T		B8	PT26A	0	T	
A5	PT25B	0	C		A5	PT25B	0	C	
GND	GND0	0			GND	GND0	0		
B6	PT25A	0	T		B6	PT25A	0	T	
G10	PT24B	0	C		G10	PT24B	0	C	
E10	PT24A	0	T		E10	PT24A	0	T	
F10	PT23B	0	C		F10	PT23B	0	C	
D10	PT23A	0	T		D10	PT23A	0	T	
G9	PT22B	0	C		G9	PT22B	0	C	
E9	PT22A	0	T	TDQS22	E9	PT22A	0	T	TDQS22
C9	PT21B	0	C		C9	PT21B	0	C	
GND	GND0	0			GND	GND0	0		
C8	PT21A	0	T		C8	PT21A	0	T	
F9	PT20B	0	C		F9	PT20B	0	C	
D9	PT20A	0	T		D9	PT20A	0	T	
F8	PT19B	0	C		F8	PT19B	0	C	
D7	PT19A	0	T		D7	PT19A	0	T	
D8	PT18B	0	C		D8	PT18B	0	C	
C7	PT18A	0	T		C7	PT18A	0	T	
GND	GND0	0			GND	GND0	0		
A4	PT17B	0	C		A4	PT17B	0	C	
B4	PT17A	0	T		B4	PT17A	0	T	
C4	PT16B	0	C		C4	PT16B	0	C	
C5	PT16A	0	T		C5	PT16A	0	T	
D6	PT15B	0	C		D6	PT15B	0	C	
B5	PT15A	0	T		B5	PT15A	0	T	
E6	PT14B	0	C		E6	PT14B	0	C	
C6	PT14A	0	T	TDQS14	C6	PT14A	0	T	TDQS14
A3	PT13B	0	C		A3	PT13B	0	C	
GND	GND0	0			GND	GND0	0		
B3	PT13A	0	T		B3	PT13A	0	T	
F6	PT12B	0	C		F6	PT12B	0	C	
D5	PT12A	0	T		D5	PT12A	0	T	
F7	PT11B	0	C		F7	PT11B	0	C	
E8	PT11A	0	T		E8	PT11A	0	T	
G6	PT10B	0	C		G6	PT10B	0	C	
E7	PT10A	0	T		E7	PT10A	0	T	
GND	GND0	0			GND	GND0	0		
GND	GND0	0			GND	GND0	0		
A1	GND	-			A1	GND	-		
A22	GND	-			A22	GND	-		

LFECP/EC20 and LFECP/EC33 Logic Signal Connections: 484 fpBGA (Cont.)

LFECP20/LFEC20					LFECP/LFEC33				
Ball Number	Ball Function	Bank	LVD S	Dual Function	Ball Number	Ball Function	Bank	LVD S	Dual Function
K16	VCC	-			K16	VCC	-		
K17	VCC	-			K17	VCC	-		
K6	VCC	-			K6	VCC	-		
K7	VCC	-			K7	VCC	-		
L17	VCC	-			L17	VCC	-		
L6	VCC	-			L6	VCC	-		
M17	VCC	-			M17	VCC	-		
M6	VCC	-			M6	VCC	-		
N16	VCC	-			N16	VCC	-		
N17	VCC	-			N17	VCC	-		
N6	VCC	-			N6	VCC	-		
N7	VCC	-			N7	VCC	-		
P16	VCC	-			P16	VCC	-		
P7	VCC	-			P7	VCC	-		
G11	VCCIO0	0			G11	VCCIO0	0		
H10	VCCIO0	0			H10	VCCIO0	0		
H11	VCCIO0	0			H11	VCCIO0	0		
H9	VCCIO0	0			H9	VCCIO0	0		
G12	VCCIO1	1			G12	VCCIO1	1		
H12	VCCIO1	1			H12	VCCIO1	1		
H13	VCCIO1	1			H13	VCCIO1	1		
H14	VCCIO1	1			H14	VCCIO1	1		
J15	VCCIO2	2			J15	VCCIO2	2		
K15	VCCIO2	2			K15	VCCIO2	2		
L15	VCCIO2	2			L15	VCCIO2	2		
L16	VCCIO2	2			L16	VCCIO2	2		
M15	VCCIO3	3			M15	VCCIO3	3		
M16	VCCIO3	3			M16	VCCIO3	3		
N15	VCCIO3	3			N15	VCCIO3	3		
P15	VCCIO3	3			P15	VCCIO3	3		
R12	VCCIO4	4			R12	VCCIO4	4		
R13	VCCIO4	4			R13	VCCIO4	4		
R14	VCCIO4	4			R14	VCCIO4	4		
T12	VCCIO4	4			T12	VCCIO4	4		
R10	VCCIO5	5			R10	VCCIO5	5		
R11	VCCIO5	5			R11	VCCIO5	5		
R9	VCCIO5	5			R9	VCCIO5	5		
T11	VCCIO5	5			T11	VCCIO5	5		
M7	VCCIO6	6			M7	VCCIO6	6		
M8	VCCIO6	6			M8	VCCIO6	6		
N8	VCCIO6	6			N8	VCCIO6	6		
P8	VCCIO6	6			P8	VCCIO6	6		
J8	VCCIO7	7			J8	VCCIO7	7		
K8	VCCIO7	7			K8	VCCIO7	7		

LFCEP/EC20, LFCEP/EC33 Logic Signal Connections: 672 fpBGA (Cont.)

LFCEP/EC20					LFCEP/EC33				
Ball Number	Ball Function	Bank	LVDS	Dual Function	Ball Number	Ball Function	Bank	LVDS	Dual Function
K6	PL13B	7	C		K6	PL25B	7	C	
F1	PL14A	7	T		F1	PL26A	7	T	
GND	GND7	7			GND	GND7	7		
G1	PL14B	7	C		G1	PL26B	7	C	
H1	PL15A	7	T		H1	PL27A	7	T	
J1	PL15B	7	C		J1	PL27B	7	C	
K2	PL16A	7	T		K2	PL28A	7	T	
K1	PL16B	7	C		K1	PL28B	7	C	
K3	PL17A	7	T		K3	PL29A	7	T	
L3	PL17B	7	C		L3	PL29B	7	C	
L2	PL18A	7	T		L2	PL30A	7	T	
GND	GND7	7			GND	GND7	7		
L1	PL18B	7	C		L1	PL30B	7	C	
M3	PL19A	7	T	LDQS19	M3	PL31A	7	T	LDQS31
M4	PL19B	7	C		M4	PL31B	7	C	
M1	PL20A	7	T		M1	PL32A	7	T	
M2	PL20B	7	C		M2	PL32B	7	C	
L4	PL21A	7	T		L4	PL33A	7	T	
L5	PL21B	7	C		L5	PL33B	7	C	
N2	PL22A	7	T	PCLKT7_0	N2	PL34A	7	T	PCLKT7_0
GND	GND7	7			GND	GND7	7		
N1	PL22B	7	C	PCLKC7_0	N1	PL34B	7	C	PCLKC7_0
N3	XRES	6			N3	XRES	6		
P1	PL24A	6	T		P1	PL36A	6	T	
P2	PL24B	6	C		P2	PL36B	6	C	
L7	PL25A	6	T		L7	PL37A	6	T	
L6	PL25B	6	C		L6	PL37B	6	C	
N4	PL26A	6	T		N4	PL38A	6	T	
N5	PL26B	6	C		N5	PL38B	6	C	
R1	PL27A	6	T		R1	PL39A	6	T	
GND	GND6	6			GND	GND6	6		
R2	PL27B	6	C		R2	PL39B	6	C	
P4	PL28A	6	T	LDQS28	P4	PL40A	6	T	LDQS40
P3	PL28B	6	C		P3	PL40B	6	C	
M5	PL29A	6	T		M5	PL41A	6	T	
M6	PL29B	6	C		M6	PL41B	6	C	
T1	PL30A	6	T		T1	PL42A	6	T	
T2	PL30B	6	C		T2	PL42B	6	C	
R4	PL31A	6	T		R4	PL43A	6	T	
GND	GND6	6			GND	GND6	6		
R3	PL31B	6	C		R3	PL43B	6	C	
N6	PL32A	6	T		N6	PL44A	6	T	

LFCEP/EC20, LFCEP/EC33 Logic Signal Connections: 672 fpBGA (Cont.)

LFCEP/EC20					LFCEP/EC33				
Ball Number	Ball Function	Bank	LVDS	Dual Function	Ball Number	Ball Function	Bank	LVDS	Dual Function
U21	PR36B	3	C		U21	PR48B	3	C	
T21	PR36A	3	T	RDQS36	T21	PR48A	3	T	RDQS48
T25	PR35B	3	C		T25	PR47B	3	C	
GND	GND3	3			GND	GND3	3		
T26	PR35A	3	T		T26	PR47A	3	T	
T22	PR34B	3	C		T22	PR46B	3	C	
T23	PR34A	3	T		T23	PR46A	3	T	
T24	PR33B	3	C		T24	PR45B	3	C	
R23	PR33A	3	T		R23	PR45A	3	T	
R25	PR32B	3	C		R25	PR44B	3	C	
R24	PR32A	3	T		R24	PR44A	3	T	
R26	PR31B	3	C		R26	PR43B	3	C	
GND	GND3	3			GND	GND3	3		
P26	PR31A	3	T		P26	PR43A	3	T	
R21	PR30B	3	C		R21	PR42B	3	C	
R22	PR30A	3	T		R22	PR42A	3	T	
P25	PR29B	3	C		P25	PR41B	3	C	
P24	PR29A	3	T		P24	PR41A	3	T	
P23	PR28B	3	C		P23	PR40B	3	C	
P22	PR28A	3	T	RDQS28	P22	PR40A	3	T	RDQS40
N26	PR27B	3	C		N26	PR39B	3	C	
GND	GND3	3			GND	GND3	3		
M26	PR27A	3	T		M26	PR39A	3	T	
N21	PR26B	3	C		N21	PR38B	3	C	
P21	PR26A	3	T		P21	PR38A	3	T	
N23	PR25B	3	C		N23	PR37B	3	C	
N22	PR25A	3	T		N22	PR37A	3	T	
N25	PR24B	3	C		N25	PR36B	3	C	
N24	PR24A	3	T		N24	PR36A	3	T	
L26	PR22B	2	C	PCLKC2_0	L26	PR34B	2	C	PCLKC2_0
GND	GND2	2			GND	GND2	2		
K26	PR22A	2	T	PCLKT2_0	K26	PR34A	2	T	PCLKT2_0
M22	PR21B	2	C		M22	PR33B	2	C	
M23	PR21A	2	T		M23	PR33A	2	T	
M25	PR20B	2	C		M25	PR32B	2	C	
M24	PR20A	2	T		M24	PR32A	2	T	
M21	PR19B	2	C		M21	PR31B	2	C	
L21	PR19A	2	T	RDQS19	L21	PR31A	2	T	RDQS31
L22	PR18B	2	C		L22	PR30B	2	C	
GND	GND2	2			GND	GND2	2		
L23	PR18A	2	T		L23	PR30A	2	T	
L25	PR17B	2	C		L25	PR29B	2	C	

LFCEP/EC20, LFCEP/EC33 Logic Signal Connections: 672 fpBGA (Cont.)

LFCEP/EC20					LFCEP/EC33				
Ball Number	Ball Function	Bank	LVDS	Dual Function	Ball Number	Ball Function	Bank	LVDS	Dual Function
M10	GND	-			M10	GND	-		
M11	GND	-			M11	GND	-		
M12	GND	-			M12	GND	-		
M13	GND	-			M13	GND	-		
M14	GND	-			M14	GND	-		
M15	GND	-			M15	GND	-		
M16	GND	-			M16	GND	-		
M17	GND	-			M17	GND	-		
N10	GND	-			N10	GND	-		
N11	GND	-			N11	GND	-		
N12	GND	-			N12	GND	-		
N13	GND	-			N13	GND	-		
N14	GND	-			N14	GND	-		
N15	GND	-			N15	GND	-		
N16	GND	-			N16	GND	-		
N17	GND	-			N17	GND	-		
P10	GND	-			P10	GND	-		
P11	GND	-			P11	GND	-		
P12	GND	-			P12	GND	-		
P13	GND	-			P13	GND	-		
P14	GND	-			P14	GND	-		
P15	GND	-			P15	GND	-		
P16	GND	-			P16	GND	-		
P17	GND	-			P17	GND	-		
R10	GND	-			R10	GND	-		
R11	GND	-			R11	GND	-		
R12	GND	-			R12	GND	-		
R13	GND	-			R13	GND	-		
R14	GND	-			R14	GND	-		
R15	GND	-			R15	GND	-		
R16	GND	-			R16	GND	-		
R17	GND	-			R17	GND	-		
T10	GND	-			T10	GND	-		
T11	GND	-			T11	GND	-		
T12	GND	-			T12	GND	-		
T13	GND	-			T13	GND	-		
T14	GND	-			T14	GND	-		
T15	GND	-			T15	GND	-		
T16	GND	-			T16	GND	-		
T17	GND	-			T17	GND	-		
U10	GND	-			U10	GND	-		
U11	GND	-			U11	GND	-		

LatticeECP Commercial

Part Number	I/Os	Grade	Package	Pins	Temp.	LUTs
LFCEP6E-3F484C	224	-3	fpBGA	484	COM	6.1K
LFCEP6E-4F484C	224	-4	fpBGA	484	COM	6.1K
LFCEP6E-5F484C	224	-5	fpBGA	484	COM	6.1K
LFCEP6E-3F256C	195	-3	fpBGA	256	COM	6.1K
LFCEP6E-4F256C	195	-4	fpBGA	256	COM	6.1K
LFCEP6E-5F256C	195	-5	fpBGA	256	COM	6.1K
LFCEP6E-3Q208C	147	-3	PQFP	208	COM	6.1K
LFCEP6E-4Q208C	147	-4	PQFP	208	COM	6.1K
LFCEP6E-5Q208C	147	-5	PQFP	208	COM	6.1K
LFCEP6E-3T144C	97	-3	TQFP	144	COM	6.1K
LFCEP6E-4T144C	97	-4	TQFP	144	COM	6.1K
LFCEP6E-5T144C	97	-5	TQFP	144	COM	6.1K

Part Number	I/Os	Grade	Package	Pins	Temp.	LUTs
LFCEP10E-3F484C	288	-3	fpBGA	484	COM	10.2K
LFCEP10E-4F484C	288	-4	fpBGA	484	COM	10.2K
LFCEP10E-5F484C	288	-5	fpBGA	484	COM	10.2K
LFCEP10E-3F256C	195	-3	fpBGA	256	COM	10.2K
LFCEP10E-4F256C	195	-4	fpBGA	256	COM	10.2K
LFCEP10E-5F256C	195	-5	fpBGA	256	COM	10.2K
LFCEP10E-3Q208C	147	-3	PQFP	208	COM	10.2K
LFCEP10E-4Q208C	147	-4	PQFP	208	COM	10.2K
LFCEP10E-5Q208C	147	-5	PQFP	208	COM	10.2K

Part Number	I/Os	Grade	Package	Pins	Temp.	LUTs
LFCEP15E-3F484C	352	-3	fpBGA	484	COM	15.3K
LFCEP15E-4F484C	352	-4	fpBGA	484	COM	15.3K
LFCEP15E-5F484C	352	-5	fpBGA	484	COM	15.3K
LFCEP15E-3F256C	195	-3	fpBGA	256	COM	15.3K
LFCEP15E-4F256C	195	-4	fpBGA	256	COM	15.3K
LFCEP15E-5F256C	195	-5	fpBGA	256	COM	15.3K

Part Number	I/Os	Grade	Package	Pins	Temp.	LUTs
LFCEP20E-3F672C	400	-3	fpBGA	672	COM	19.7K
LFCEP20E-4F672C	400	-4	fpBGA	672	COM	19.7K
LFCEP20E-5F672C	400	-5	fpBGA	672	COM	19.7K
LFCEP20E-3F484C	360	-3	fpBGA	484	COM	19.7K
LFCEP20E-4F484C	360	-4	fpBGA	484	COM	19.7K
LFCEP20E-5F484C	360	-5	fpBGA	484	COM	19.7K

Part Number	I/Os	Grade	Package	Pins	Temp.	LUTs
LFCEP33E-3F672C	496	-3	fpBGA	672	COM	32.8K
LFCEP33E-4F672C	496	-4	fpBGA	672	COM	32.8K
LFCEP33E-5F672C	496	-5	fpBGA	672	COM	32.8K

LatticeEC Commercial (Continued)

Part Number	I/Os	Grade	Package	Pins/Balls	Temp.	LUTs
LFEC10E-4FN256C	195	-4	Lead-Free fpBGA	256	COM	10.2K
LFEC10E-5FN256C	195	-5	Lead-Free fpBGA	256	COM	10.2K
LFEC10E-3QN208C	147	-3	Lead-Free PQFP	208	COM	10.2K
LFEC10E-4QN208C	147	-4	Lead-Free PQFP	208	COM	10.2K
LFEC10E-5QN208C	147	-5	Lead-Free PQFP	208	COM	10.2K

Part Number	I/Os	Grade	Package	Pins/Balls	Temp.	LUTs
LFEC15E-3FN484C	352	-3	Lead-Free fpBGA	484	COM	15.3K
LFEC15E-4FN484C	352	-4	Lead-Free fpBGA	484	COM	15.3K
LFEC15E-5FN484C	352	-5	Lead-Free fpBGA	484	COM	15.3K
LFEC15E-3FN256C	195	-3	Lead-Free fpBGA	256	COM	15.3K
LFEC15E-4FN256C	195	-4	Lead-Free fpBGA	256	COM	15.3K
LFEC15E-5FN256C	195	-5	Lead-Free fpBGA	256	COM	15.3K

Part Number	I/Os	Grade	Package	Pins/Balls	Temp.	LUTs
LFEC20E-3FN672C	400	-3	Lead-Free fpBGA	672	COM	19.7K
LFEC20E-4FN672C	400	-4	Lead-Free fpBGA	672	COM	19.7K
LFEC20E-5FN672C	400	-5	Lead-Free fpBGA	672	COM	19.7K
LFEC20E-3FN484C	360	-3	Lead-Free fpBGA	484	COM	19.7K
LFEC20E-4FN484C	360	-4	Lead-Free fpBGA	484	COM	19.7K
LFEC20E-5FN484C	360	-5	Lead-Free fpBGA	484	COM	19.7K

Part Number	I/Os	Grade	Package	Pins/Balls	Temp.	LUTs
LFEC33E-3FN672C	496	-3	Lead-Free fpBGA	672	COM	32.8K
LFEC33E-4FN672C	496	-4	Lead-Free fpBGA	672	COM	32.8K
LFEC33E-5FN672C	496	-5	Lead-Free fpBGA	672	COM	32.8K
LFEC33E-3FN484C	360	-3	Lead-Free fpBGA	484	COM	32.8K
LFEC33E-4FN484C	360	-4	Lead-Free fpBGA	484	COM	32.8K
LFEC33E-5FN484C	360	-5	Lead-Free fpBGA	484	COM	32.8K

Date	Version	Section	Change Summary
December 2004	01.4	Architecture	Updated Hot Socketing Recommended Power Up Sequence section.
		Pinout Information	Added LFEC1, LFEC3, LFECP/EC10, LFECP/EC15 to Pin Information
			Added LFEC1, LFEC3, LFECP/EC10, LFECP/EC15 to Power Supply and NC Connections
			Added LFEC1 and LFEC3 100 TQFP Pinout
			Added LFEC1 and LFEC3 144 TQFP Pinout
			Added LFEC1, LFEC3 and LFECP/EC10 208 PQFP Pinout
			Added LFEC3, LFECP/EC10 and LFECP/EC15 256 fpBGA Pinout
		Ordering Information	Added LFECP/EC10 and LFECP/EC15 484 fpBGA Pinout
			Added Lead-Free Package Designators
Supplemental Information	Updated list of technical notes.		
April 2005	01.5	Architecture	EBR memory support section has been updated with clarification.
			Updated sysIO buffer pair section.
		DC & Switching Characteristics	Hot Socketing Specification has been updated.
			DC Electrical Characteristics table (I_{IL} , I_{IH}) has been updated.
			Supply Current (Standby) table has been updated.
			Initialization Supply Current table has been updated.
			External Switching Characteristics section has been updated.
			Removed t_{RSTW} spec. from PLL Parameter table.
		Pinout Information	t_{RST} specifications have been updated.
			sysCONFIG Port Timing Specifications (t_{BSC} , t_{ODISS} , t_{PRGMRJ}) have been updated.
			Added LFECP/EC33 Pinout Information
			Pin Information Summary table has been updated.
			Power Supply and NC Connection table has been updated.
			484-fpBGA logic connection has been updated (Ball # J6, J17, P6 and P17 for ECP/EC33 are now called VCCPLL).
672-fpBGA logic connection has been updated (Ball # K19, L8, U19, U8 for ECP/EC33 are now called VCCPLL).			
May 2005	01.6	Introduction	ECP/EC33 EBR SRAM Bits and Blocks have been updated to 498K and 54 respectively.
		Architecture	Table 2-10 has been updated (ECP/EC33 EBR SRAM Bits and Blocks have been updated to 498K and 54 respectively.)
			Recommended Power Up Sequence section has been removed.
		DC & Switching Characteristics	Supply Current (Standby) table has been updated.
			Initialization Supply Current table has been updated.
			Vos test condition has been updated to $(VOP+VOM)/2$.
			Register-to-Register performance table has been updated (rev. G 0.27).
			External switching characteristics have been updated (rev. G 0.27).
			Internal timing parameters have been updated (rev. G 0.27).
		Pinout Information	Timing adders have been updated (rev. G 0.27).
			sysCONFIG port timing specifications have been updated.
		Ordering Information	Pin Information Summary table has been updated.
			Power Supply and NC Connection table has been updated.
			OPN list has been updated.