

Welcome to [E-XFL.COM](https://www.e-xfl.com)

Embedded - System On Chip (SoC): The Heart of Modern Embedded Systems

Embedded - System On Chip (SoC) refers to an integrated circuit that consolidates all the essential components of a computer system into a single chip. This includes a microprocessor, memory, and other peripherals, all packed into one compact and efficient package. SoCs are designed to provide a complete computing solution, optimizing both space and power consumption, making them ideal for a wide range of embedded applications.

What are Embedded - System On Chip (SoC)?

System On Chip (SoC) integrates multiple functions of a computer or electronic system onto a single chip. Unlike traditional multi-chip solutions, SoCs combine a central

Details

Product Status	Active
Architecture	MCU, FPGA
Core Processor	ARM® Cortex®-M3
Flash Size	256KB
RAM Size	64KB
Peripherals	DDR, PCIe, SERDES
Connectivity	CANbus, Ethernet, I ² C, SPI, UART/USART, USB
Speed	166MHz
Primary Attributes	FPGA - 60K Logic Modules
Operating Temperature	-40°C ~ 100°C (TJ)
Package / Case	325-TFBGA, FCBGA
Supplier Device Package	325-FCBGA (11x11)
Purchase URL	https://www.e-xfl.com/product-detail/microchip-technology/m2s060-1fcsg325i

Figures

Figure 1	High Temperature Data Retention (HTR)	9
Figure 2	Timing Model	15
Figure 3	Input Buffer AC Loading	17
Figure 4	Output Buffer AC Loading	18
Figure 5	Tristate Buffer for Enable Path Test Point	19
Figure 6	Timing Model for Input Register	65
Figure 7	I/O Register Input Timing Diagram	66
Figure 8	Timing Model for Output/Enable Register	68
Figure 9	I/O Register Output Timing Diagram	69
Figure 10	Input DDR Module	70
Figure 11	Input DDR Timing Diagram	71
Figure 12	Output DDR Module	73
Figure 13	Output DDR Timing Diagram	74
Figure 14	LUT-4	75
Figure 15	Sequential Module	76
Figure 16	Sequential Module Timing Diagram	77
Figure 17	Power-up to Functional Timing Diagram for SmartFusion2	115
Figure 18	Power-up to Functional Timing Diagram for IGLOO2	116
Figure 19	DEVRST_N to Functional Timing Diagram for SmartFusion2	117
Figure 20	DEVRST_N to Functional Timing Diagram for IGLOO2	119
Figure 21	I2C Timing Parameter Definition	125
Figure 22	SPI Timing for a Single Frame Transfer in Motorola Mode (SPH = 1)	128
Figure 23	SPI Timing for a Single Frame Transfer in Motorola Mode (SPH = 1)	131

1. For flash programming and retention maximum limits, see Table 5, page 7. For recommended operating conditions, see Table 4, page 6.

Table 4 • Recommended Operating Conditions

Parameter	Symbol	Min	Typ	Max	Unit	Conditions
Operating junction temperature	T_J	0	25	85	°C	Commercial
		-40	25	100	°C	Industrial
Programming junction temperatures ¹	T_J	0	25	85	°C	Commercial
		-40	25	100	°C	Industrial
DC core supply voltage. Must always power this pin.	V_{DD}	1.14	1.2	1.26	V	
Power supply for charge pumps (for normal operation and programming) for the 005, 010, 025, 050, 060 devices	V_{PP}	2.375	2.5	2.625	V	2.5 V range
		3.15	3.3	3.45	V	3.3 V range
Power supply for charge pumps (for normal operation and programming) for the 090 and 150 devices	V_{PP}	3.15	3.3	3.45	V	3.3 V range
Analog power pad for MDDR PLL	MSS_MDDR_PLL_VDDA	2.375	2.5	2.625	V	2.5 V range
		3.15	3.3	3.45	V	3.3 V range
Analog power pad for MDDR PLL	HPMS_MDDR_PLL_VDDA	2.375	2.5	2.625	V	2.5 V range
		3.15	3.3	3.45	V	3.3 V range
Analog power pad for FDDR PLL	FDDR_PLL_VDDA	2.375	2.5	2.625	V	2.5 V range
		3.15	3.3	3.45	V	3.3 V range
Analog power pad for MDDR PLL	PLL0_PLL1_MSS_MDDR_V DDA	2.375	2.5	2.625	V	2.5 V range
		3.15	3.3	3.45	V	3.3 V range
Analog power pad for MDDR PLL	PLL0_PLL1_HPMS_MDDR_ VDDA	2.375	2.5	2.625	V	2.5 V range
		3.15	3.3	3.45	V	3.3 V range
Analog power pad for PLL0 to PLL5	CCC_XX[01]_PLL_VDDA	2.375	2.5	2.625	V	2.5 V range
		3.15	3.3	3.45	V	3.3 V range
High supply voltage for PLL SerDes[01]	SERDES_[01]_PLL_VDDA	2.375	2.5	2.625	V	2.5 V range
		3.15	3.3	3.45	V	3.3 V range
Analog power for SerDes[01] PLL Lane 0 to Lane 3. This is a 2.5 V SerDes internal PLL supply.	SERDES_[01]_L[0123]_VD DAPLL	2.375	2.5	2.625	V	
TX/RX analog I/O voltage. Low voltage power for the lanes of SerDesIF0. This is a 1.2 V SerDes PMA supply.	SERDES_[01]_L[0123]_VD DAIO	1.14	1.2	1.26	V	
PCIe/PCS power supply	SERDES_[01]_VDD	1.14	1.2	1.26	V	
1.2 V DC supply voltage	V_{DDix}	1.14	1.2	1.26	V	
1.5 V DC supply voltage	V_{DDix}	1.425	1.5	1.575	V	
1.8 V DC supply voltage	V_{DDix}	1.71	1.8	1.89	V	
2.5 V DC supply voltage	V_{DDix}	2.375	2.5	2.625	V	

where

- θ_{JA} = Junction-to-air thermal resistance
- θ_{JB} = Junction-to-board thermal resistance
- θ_{JC} = Junction-to-case thermal resistance
- T_J = Junction temperature
- T_A = Ambient temperature
- T_B = Board temperature (measured 1.0 mm away from the package edge)
- T_C = Case temperature
- P = Total power dissipated by the device

Table 9 • Package Thermal Resistance of SmartFusion2 and IGLOO2 Devices

Device	Still Air	1.0 m/s	2.5 m/s	θ_{JB}	θ_{JC}	Unit
	θ_{JA}					
005						
FG484	19.36	15.81	14.63	9.74	5.27	°C/W
VF256	41.30	38.16	35.30	28.41	3.94	°C/W
VF400	20.19	16.94	15.41	8.86	4.95	°C/W
TQ144	42.80	36.80	34.50	37.20	10.80	°C/W
010						
FG484	18.22	14.83	13.62	8.83	4.92	°C/W
VF256	37.36	34.26	31.45	24.84	7.89	°C/W
VF400	19.40	15.75	14.22	8.11	4.22	°C/W
TQ144	38.60	32.60	30.30	31.80	8.60	°C/W
025						
FG484	17.03	13.66	12.45	7.66	4.18	°C/W
VF256	33.85	30.59	27.85	21.63	6.13	°C/W
VF400	18.36	14.89	13.36	7.12	3.41	°C/W
FCS325	29.17	24.87	23.12	14.44	2.31	°C/W
050						
FG484	15.29	12.19	10.99	6.27	3.24	°C/W
FG896	14.70	12.50	10.90	7.20	4.90	°C/W
VF400	17.53	14.17	12.63	6.32	2.81	°C/W
FCS325	27.38	23.18	21.41	12.47	1.59	°C/W
060						
FG484	15.40	12.06	10.85	6.14	3.15	°C/W
FG676	15.49	12.21	11.06	7.07	3.87	°C/W
VF400	17.45	14.01	12.47	6.22	2.69	°C/W
FCS325	27.03	22.91	21.25	12.33	1.54	°C/W
090						
FG484	14.64	11.37	10.16	5.43	2.77	°C/W
FG676	14.52	11.19	10.37	6.17	3.24	°C/W
FCS325	26.63	22.26	20.13	14.24	2.50	°C/W

The following table lists the minimum and maximum I/O weak pull-up/pull-down resistance values of MSIO I/O bank at V_{OH}/V_{OL} Level.

Table 26 • I/O Weak Pull-Up/Pull-Down Resistances for MSIO I/O Bank

V_{DDI} Domain	R(WEAK PULL-UP) at V_{OH} (Ω)		R(WEAK PULL-DOWN) at V_{OL} (Ω)	
	Min	Max	Min	Max
3.3 V	9.9K	17.1K	9.98K	17.5K
2.5 V ^{1, 2}	10K	17.6K	10.1K	18.4K
1.8 V ^{1, 2}	10.4K	19.1K	10.4K	20.4K
1.5 V ^{1, 2}	10.7K	20.4K	10.8K	22.2K
1.2 V ^{1, 2}	11.3K	23.2K	11.5K	26.7K

1. $R(\text{WEAK PULL-DOWN}) = (V_{OL\text{spec}})/I(\text{WEAK PULL-DOWN MAX})$.
2. $R(\text{WEAK PULL-UP}) = (V_{DDI\text{max}} - V_{OH\text{spec}})/I(\text{WEAK PULL-UP MIN})$.

The following table lists the minimum and maximum I/O weak pull-up/pull-down resistance values of MSIOD I/O bank at V_{OH}/V_{OL} Level.

Table 27 • I/O Weak Pull-up/Pull-down Resistances for MSIOD I/O Bank

V_{DDI} Domain	R(WEAK PULL-UP) at V_{OH} (Ω)		R(WEAK PULL-DOWN) at V_{OL} (Ω)	
	Min	Max	Min	Max
2.5 V ^{1, 2}	9.6K	16.6K	9.5K	16.4K
1.8 V ^{1, 2}	9.7K	17.3K	9.7K	17.1K
1.5 V ^{1, 2}	9.9K	18K	9.8K	17.6K
1.2 V ^{1, 2}	10.3K	19.6K	10K	19.1K

1. $R(\text{WEAK PULL-DOWN}) = (V_{OL\text{spec}})/I(\text{WEAK PULL-DOWN MAX})$.
2. $R(\text{WEAK PULL-UP}) = (V_{DDI\text{max}} - V_{OH\text{spec}})/I(\text{WEAK PULL-UP MIN})$.

The following table lists the hysteresis voltage value for schmitt trigger mode input buffers.

Table 28 • Schmitt Trigger Input Hysteresis

Input Buffer Configuration	Hysteresis Value (Typical, unless otherwise noted)
3.3 V LVTTTL/LVCMOS/ PCI/PCI-X	$0.05 \times V_{DDI}$ (worst-case)
2.5 V LVCMOS	$0.05 \times V_{DDI}$ (worst-case)
1.8 V LVCMOS	$0.1 \times V_{DDI}$ (worst-case)
1.5 V LVCMOS	60 mV
1.2 V LVCMOS	20 mV

2.3.5.7 2.5 V LVCMOS

LVCMOS 2.5 V is a general standard for 2.5 V applications and is supported in IGLOO2 FPGA and SmartFusion2 SoC FPGAs that are in compliance with the JEDEC specification JESD8-5A.

Minimum and Maximum DC/AC Input and Output Levels Specification

Table 38 • LVCMOS 2.5 V DC Recommended DC Operating Conditions

Parameter	Symbol	Min	Typ	Max	Unit
Supply voltage	V_{DDI}	2.375	2.5	2.625	V

Table 39 • LVCMOS 2.5 V DC Input Voltage Specification

Parameter	Symbol	Min	Max	Unit
DC input logic high (for MSIOD and DDRIO I/O banks)	V_{IH} (DC)	1.7	2.625	V
DC input logic high (for MSIO I/O bank)	V_{IH} (DC)	1.7	3.45	V
DC input logic low	V_{IL} (DC)	-0.3	0.7	V
Input current high ¹	I_{IH} (DC)			
Input current low ¹	I_{IL} (DC)			

1. See [Table 24](#), page 22.

Table 40 • LVCMOS 2.5 V DC Output Voltage Specification

Parameter	Symbol	Min	Max	Unit
DC output logic high	V_{OH} ¹	$V_{DDI} - 0.4$	-	V
DC output logic low	V_{OL} ²		0.4	V

1. The VOH/VOL test points selected ensure compliance with LVCMOS 2.5 V JEDEC8-5A requirements.

Table 41 • LVCMOS 2.5 V AC Minimum and Maximum Switching Speed

Parameter	Symbol	Max	Unit	Conditions
Maximum data rate (for DDRIO I/O bank)	D_{MAX}	400	Mbps	AC loading: 17 pF load, maximum drive/slew
Maximum data rate (for MSIO I/O bank)	D_{MAX}	410	Mbps	AC loading: 17 pF load, maximum drive/slew
Maximum data rate (for MSIOD I/O bank)	D_{MAX}	420	Mbps	AC loading: 17 pF load, maximum drive/slew

Table 42 • LVCMOS 2.5 V AC Calibrated Impedance Option

Parameter	Symbol	Typ	Unit
Supported output driver calibrated impedance (for DDRIO I/O bank)	Rodt_cal	75, 60, 50, 33, 25, 20	Ω

Table 48 • LVCMOS 2.5 V Transmitter Characteristics for MSIOD Bank (Output and Tristate Buffers)

Output Drive Selection	Slew Control	T _{DP}		T _{ZL}		T _{ZH}		T _{HZ} ¹		T _{LZ} ¹		Unit
		-1	-Std	-1	-Std	-1	-Std	-1	-Std	-1	-Std	
2 mA	Slow	2.206	2.596	2.678	3.15	2.64	3.106	4.935	5.805	4.74	5.576	ns
4 mA	Slow	1.835	2.159	2.242	2.637	2.256	2.654	5.413	6.368	5.15	6.059	ns
6 mA	Slow	1.709	2.01	2.132	2.508	2.167	2.549	5.813	6.838	5.499	6.469	ns
8 mA	Slow	1.63	1.918	1.958	2.303	2.012	2.367	6.226	7.324	5.816	6.842	ns
12 mA	Slow	1.648	1.939	1.86	2.187	1.921	2.259	6.519	7.669	6.027	7.09	ns

1. Delay increases with drive strength are inherent to built-in slew control circuitry for simultaneous switching output (SSO) management.

2.3.5.8 1.8 V LVCMOS

LVCMOS 1.8 is a general standard for 1.8 V applications and is supported in IGLOO2 FPGAs and SmartFusion2 SoC FPGAs in compliance to the JEDEC specification JESD8-7A.

Minimum and Maximum DC/AC Input and Output Levels Specification

Table 49 • LVCMOS 1.8 V DC Recommended Operating Conditions

Parameter	Symbol	Min	Typ	Max	Unit
LVCMOS 1.8 V DC Recommended Operating Conditions					
Supply voltage	V _{DDI}	1.710	1.8	1.89	V

Table 50 • LVCMOS 1.8 V DC Input Voltage Specification

Parameter	Symbol	Min	Max	Unit
DC input logic high (for MSIOD and DDRIO I/O banks)	V _{IH} (DC)	0.65 × V _{DDI}	1.89	V
DC input logic high (for MSIO I/O bank)	V _{IH} (DC)	0.65 × V _{DDI}	3.45	V
DC input logic low	V _{IL} (DC)	-0.3	0.35 × V _{DDI}	V
Input current high ¹	I _{IH} (DC)			-
Input current low ¹	I _{IL} (DC)			-

1. See Table 24, page 22.

Table 51 • LVCMOS 1.8 V DC Output Voltage Specification

Parameter	Symbol	Min	Max	Unit
DC output logic high	V _{OH}	V _{DDI} - 0.45		V
DC output logic low	V _{OL}		0.45	V

Table 52 • LVCMOS 1.8 V Minimum and Maximum AC Switching Speed

Parameter	Symbol	Max	Unit	Conditions
Maximum data rate (for DDRIO I/O bank) ¹	D _{MAX}	400	Mbps	AC loading: 17 pF load, maximum drive/slew
Maximum data rate (for MSIO I/O bank)	D _{MAX}	295	Mbps	AC loading: 17 pF load, maximum drive/slew
Maximum data rate (for MSIOD I/O bank) ¹	D _{MAX}	400	Mbps	AC loading: 17 pF load, maximum drive/slew

1. Maximum Data Rate applies for Drive Strength 8 mA and above, All Slews.

Table 85 • LVCMOS 1.2 V Transmitter Characteristics for MSIOD I/O Bank (Output and Tristate Buffers)

Output Drive Selection	Slew Control	T _{DP}		T _{ZL}		T _{ZH}		T _{HZ} ¹		T _{LZ} ¹		Unit
		-1	-Std	-1	-Std	-1	-Std	-1	-Std	-1	-Std	
2 mA	Slow	3.883	4.568	4.868	5.726	5.329	6.269	7.994	9.404	7.527	8.855	ns
4 mA	Slow	3.774	4.44	4.188	4.926	4.613	5.426	8.972	10.555	8.315	9.782	ns

1. Delay increases with drive strength are inherent to built-in slew control circuitry for simultaneous switching output (SSO) management.

2.3.5.11 3.3 V PCI/PCIX

Peripheral Component Interface (PCI) for 3.3 V standards specify support for 33 MHz and 66 MHz PCI bus applications.

Minimum and Maximum DC/AC Input and Output Levels Specification (Applicable to MSIO Bank Only)

Table 86 • PCI/PCI-X DC Recommended Operating Conditions

Parameter	Symbol	Min	Typ	Max	Unit
Supply voltage	V _{DDI}	3.15	3.3	3.45	V

Table 87 • PCI/PCI-X DC Input Voltage Specification

Parameter	Symbol	Min	Max	Unit
DC input voltage	V _I	0	3.45	V
Input current high ¹	I _{IH} (DC)			
Input current low ¹	I _{IL} (DC)			

1. See Table 24, page 22.

Table 88 • PCI/PCI-X DC Output Voltage Specification

Parameter	Symbol	Min	Typ	Max	Unit
DC output logic high	V _{OH}		Per PCI specification		V
DC output logic low	V _{OL}		Per PCI specification		V

Table 89 • PCI/PCI-X Minimum and Maximum AC Switching Speed

Parameter	Symbol	Max	Unit	Conditions
Maximum data rate (MSIO I/O bank)	D _{MAX}	630	Mbps	AC Loading: per JEDEC specifications

Table 90 • PCI/PCI-X AC Test Parameter Specifications

Parameter	Symbol	Typ	Unit
Measuring/trip point for data path (falling edge)	V _{TRIP}	0.615 × V _{DDI}	V
Measuring/trip point for data path (rising edge)	V _{TRIP}	0.285 × V _{DDI}	V
Resistance for data test path	R _{TT_TEST}	25	Ω
Resistance for enable path (T _{ZH} , T _{ZL} , T _{HZ} , T _{LZ})	R _{ENT}	2K	Ω
Capacitive loading for enable path (T _{ZH} , T _{ZL} , T _{HZ} , T _{LZ})	C _{ENT}	5	pF
Capacitive loading for data path (T _{DP})	C _{LOAD}	10	pF

AC Switching Characteristics

Worst commercial-case conditions: $T_J = 85\text{ }^\circ\text{C}$, $V_{DD} = 1.14\text{ V}$, $V_{DDI} = 3.0\text{ V}$

Table 91 • PCI/PCIX AC Switching Characteristics for Receiver for MSIO I/O Bank (Input Buffers)

On-Die Termination (ODT)	T_{PY}		T_{PYS}		Unit
	-1	-Std	-1	-Std	
None	2.229	2.623	2.238	2.633	ns

Table 92 • PCI/PCIX AC switching Characteristics for Transmitter for MSIO I/O Bank (Output and Tristate Buffers)

T_{DP}		T_{ZL}		T_{ZH}		T_{HZ}		T_{LZ}		Unit
-1	-Std	-1	-Std	-1	-Std	-1	-Std	-1	-Std	
2.146	2.525	2.043	2.404	2.084	2.452	6.095	7.171	5.558	6.539	ns

2.3.6 Memory Interface and Voltage Referenced I/O Standards

This section describes High-Speed Transceiver Logic (HSTL) memory interface and voltage reference I/O standards.

2.3.6.1 High-Speed Transceiver Logic (HSTL)

The HSTL standard is a general purpose high-speed bus standard sponsored by IBM (EIA/JESD8-6). IGLOO2 FPGA and SmartFusion2 SoC FPGA devices support two classes of the 1.5 V HSTL. These differential versions of the standard require a differential amplifier input buffer and a push-pull output buffer.

Minimum and Maximum DC/AC Input and Output Levels Specification (Applicable to DDRIO Bank Only)

Table 93 • HSTL Recommended DC Operating Conditions

Parameter	Symbol	Min	Typ	Max	Unit
Supply voltage	V_{DDI}	1.425	1.5	1.575	V
Termination voltage	V_{TT}	0.698	0.750	0.803	V
Input reference voltage	V_{REF}	0.698	0.750	0.803	V

Table 94 • HSTL DC Input Voltage Specification

Parameter	Symbol	Min	Max	Unit
DC input logic high	V_{IH} (DC)	$V_{REF} + 0.1$	1.575	V
DC input logic low	V_{IL} (DC)	-0.3	$V_{REF} - 0.1$	V
Input current high ¹	I_{IH} (DC)			
Input current low ¹	I_{IL} (DC)			

1. See Table 24, page 22.

Table 131 • SSTL15 DC Output Voltage Specification (for DDRIO I/O Bank Only)

Parameter	Symbol	Min	Max	Unit
DDR3/SSTL15 Class I (DDR3 Reduced Drive)				
DC output logic high	V_{OH}	$0.8 \times V_{DDI}$		V
DC output logic low	V_{OL}		$0.2 \times V_{DDI}$	V
Output minimum source DC current	I_{OH} at V_{OH}	6.5		mA
Output minimum sink current	I_{OL} at V_{OL}	-6.5		mA
DDR3/SSTL15 Class II (DDR3 Full Drive)				
DC output logic high	V_{OH}	$0.8 \times V_{DDI}$		V
DC output logic low	V_{OL}		$0.2 \times V_{DDI}$	V
Output minimum source DC current	I_{OH} at V_{OH}	7.6		mA
Output minimum sink current	I_{OL} at V_{OL}	-7.6		mA

Table 132 • SSTL15 DC Differential Voltage Specification (for DDRIO I/O Bank Only)

Parameter	Symbol	Min	Unit
DC input differential voltage	V_{ID}	0.2	V

Note: To meet JEDEC electrical compliance, use DDR3 full drive transmitter.

Table 133 • SSTL15 AC SSTL15 Minimum and Maximum AC Switching Speed (for DDRIO I/O Bank Only)

Parameter	Symbol	Min	Max	Unit
AC input differential voltage	V_{DIFF} (AC)	0.3		V
AC differential cross point voltage	V_x (AC)	$0.5 \times V_{DDI} - 0.150$	$0.5 \times V_{DDI} + 0.150$	V

Table 134 • SSTL15 Minimum and Maximum AC Switching Speed (for DDRIO I/O Bank Only)

Parameter	Symbol	Max	Unit	Conditions
Maximum data rate	D_{MAX}	667	Mbps	AC loading: per JEDEC specifications

Table 135 • SSTL15 AC Calibrated Impedance Option (for DDRIO I/O Bank Only)

Parameter	Symbol	Typ	Unit	Conditions
Supported output driver calibrated impedance	R_{REF}	34, 40	Ω	Reference resistor = 240 Ω
Effective impedance value (ODT)	R_{TT}	20, 30, 40, 60, 120	Ω	Reference resistor = 240 Ω

Table 136 • SSTL15 AC Test Parameter Specifications (for DDRIO I/O Bank Only)

Parameter	Symbol	Typ	Unit
Measuring/trip point for data path	V_{TRIP}	0.75	V
Resistance for enable path (T_{ZH} , T_{ZL} , T_{HZ} , T_{LZ})	R_{ENT}	2K	Ω
Capacitive loading for enable path (T_{ZH} , T_{ZL} , T_{HZ} , T_{LZ})	C_{ENT}	5	pF
Reference resistance for data test path for SSTL15 Class I (T_{DP})	RTT_TEST	50	Ω
Reference resistance for data test path for SSTL15 Class II (T_{DP})	RTT_TEST	25	Ω
Capacitive loading for data path (T_{DP})	C_{LOAD}	5	pF

AC Switching Characteristics

Worst commercial-case conditions: $T_J = 85\text{ }^\circ\text{C}$, $V_{DD} = 1.14\text{ V}$, $V_{DDI} = 1.425\text{ V}$

Table 137 • DDR3/SSTL15 Receiver Characteristics for DDRIO I/O Bank – with Calibration Only

	On-Die Termination (ODT)	T_{PY}		Unit
		-1	-Std	
Pseudo differential	None	1.605	1.888	ns
	20	1.616	1.901	ns
	30	1.613	1.897	ns
	40	1.611	1.895	ns
	60	1.609	1.893	ns
	120	1.607	1.89	ns
True differential	None	1.623	1.91	ns
	20	1.637	1.926	ns
	30	1.63	1.918	ns
	40	1.626	1.914	ns
	60	1.622	1.91	ns
	120	1.619	1.905	ns

Table 138 • DDR3/SSTL15 Transmitter Characteristics (Output and Tristate Buffers)

	T_{DP}		T_{ZL}		T_{ZH}		T_{HZ}		T_{LZ}		Unit
	-1	-Std	-1	-Std	-1	-Std	-1	-Std	-1	-Std	
DDR3 Reduced Drive/SSTL15 Class I (for DDRIO I/O Bank)											
Single-ended	2.533	2.98	2.522	2.967	2.523	2.968	2.427	2.855	2.428	2.856	ns
Differential	2.555	3.005	3.073	3.615	3.073	3.615	2.416	2.843	2.416	2.843	ns
DDR3 Full Drive/SSTL15 Class II (for DDRIO I/O Bank)											
Single-ended	2.53	2.977	2.514	2.958	2.516	2.96	2.422	2.849	2.425	2.852	ns
Differential	2.552	3.002	2.591	3.048	2.59	3.047	2.882	3.391	2.881	3.39	ns

Table 198 • Mini-LVDS AC Impedance Specifications

Parameter	Symbol	Typ	Unit
Termination resistance	R_T	100	Ω

Table 199 • Mini-LVDS AC Test Parameter Specifications

Parameter	Symbol	Typ	Unit
Measuring/trip point for data path	V_{TRIP}	Cross point	V
Resistance for enable path (T_{ZH} , T_{ZL} , T_{HZ} , T_{LZ})	R_{ENT}	2K	Ω
Capacitive loading for enable path (T_{ZH} , T_{ZL} , T_{HZ} , T_{LZ})	C_{ENT}	5	pF

AC Switching Characteristics

Worst commercial-case conditions: $T_J = 85^\circ\text{C}$, $V_{DD} = 1.14\text{ V}$, $V_{DDI} = 2.375\text{ V}$.

Table 200 • Mini-LVDS AC Switching Characteristics for Receiver (for MSIO I/O Bank - Input Buffers)

On-Die Termination (ODT)	T_{PY}		Unit
	-1	-Std	
None	2.855	3.359	ns
100	2.85	3.353	ns
None	2.602	3.061	ns
100	2.597	3.055	ns

Table 201 • Mini-LVDS AC Switching Characteristics for Transmitter for MSIO I/O Bank (Output and Tristate Buffers)

T_{DP}		T_{ZL}		T_{ZH}		T_{HZ}		T_{LZ}		Unit
-1	-Std	-1	-Std	-1	-Std	-1	-Std	-1	-Std	
2.097	2.467	2.308	2.715	2.296	2.701	1.964	2.31	1.949	2.293	ns

Table 202 • Mini-LVDS AC Switching Characteristics for Transmitter (for MSIOD I/O Bank - Output and Tristate Buffers)

	T_{DP}		T_{ZL}		T_{ZH}		T_{HZ}		T_{LZ}		Unit
	-1	-Std	-1	-Std	-1	-Std	-1	-Std	-1	-Std	
No pre-emphasis	1.614	1.899	1.562	1.837	1.553	1.826	1.593	1.874	1.578	1.856	ns
Min pre-emphasis	1.604	1.887	1.745	2.053	1.731	2.036	1.892	2.225	1.861	2.189	ns
Med pre-emphasis	1.521	1.79	1.753	2.062	1.737	2.043	1.9	2.235	1.868	2.197	ns
Max pre-emphasis	1.492	1.754	1.762	2.073	1.745	2.052	1.91	2.247	1.876	2.206	ns

2.3.9.4 Output DDR Module

Figure 12 • Output DDR Module

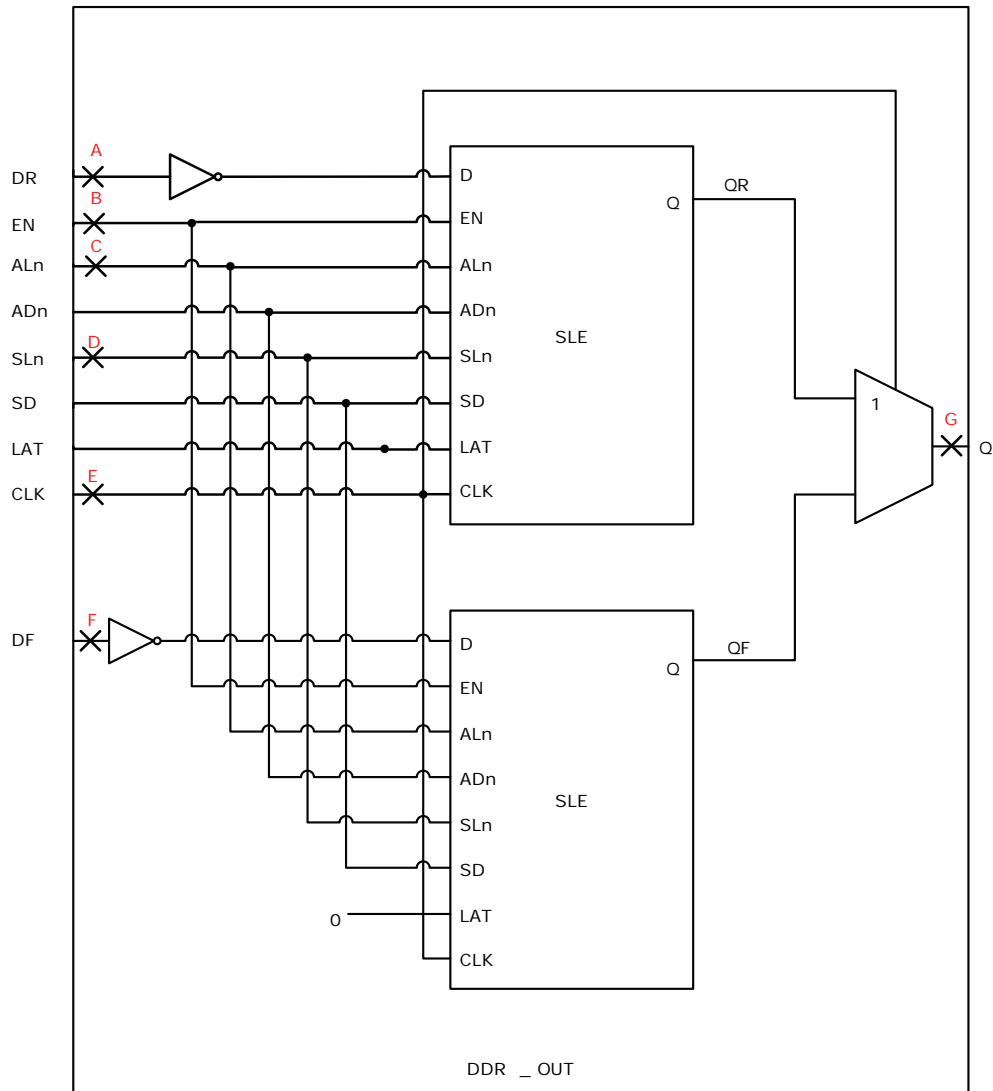

The following table lists the RAM1K18 – dual-port mode for depth × width configuration 16K × 1 in worst commercial-case conditions when $T_J = 85\text{ }^\circ\text{C}$, $V_{DD} = 1.14\text{ V}$.

Table 235 • RAM1K18 – Dual-Port Mode for Depth × Width Configuration 16K × 1

Parameter	Symbol	–1		–Std		Unit
		Min	Max	Min	Max	
Clock period	T_{CY}	2.5		2.941		ns
Clock minimum pulse width high	$T_{CLKMPWH}$	1.125		1.323		ns
Clock minimum pulse width low	$T_{CLKMPWL}$	1.125		1.323		ns
Pipelined clock period	T_{PLCY}	2.5		2.941		ns
Pipelined clock minimum pulse width high	$T_{PLCLKMPWH}$	1.125		1.323		ns
Pipelined clock minimum pulse width low	$T_{PLCLKMPWL}$	1.125		1.323		ns
Read access time with pipeline register			0.32		0.377	ns
Read access time without pipeline register	T_{CLK2Q}		2.269		2.669	ns
Access time with feed-through write timing			1.51		1.777	ns
Address setup time	T_{ADDRSU}	0.626		0.737		ns
Address hold time	T_{ADDRHD}	0.274		0.322		ns
Data setup time	T_{DSU}	0.322		0.378		ns
Data hold time	T_{DHD}	0.082		0.096		ns
Block select setup time	T_{BLKSU}	0.207		0.244		ns
Block select hold time	T_{BLKHD}	0.216		0.254		ns
Block select to out disable time (when pipelined register is disabled)	T_{BLK2Q}		1.51		1.777	ns
Block select minimum pulse width	T_{BLKMPW}	0.186		0.219		ns
Read enable setup time	T_{RDESU}	0.53		0.624		ns
Read enable hold time	T_{RDEHD}	0.071		0.083		ns
Pipelined read enable setup time (A_DOUT_EN, B_DOUT_EN)	$T_{RDPLESU}$	0.248		0.291		ns
Pipelined read enable hold time (A_DOUT_EN, B_DOUT_EN)	$T_{RDPLEHD}$	0.102		0.12		ns
Asynchronous reset to output propagation delay	T_{R2Q}		1.547		1.82	ns
Asynchronous reset removal time	T_{RSTREM}	0.506		0.595		ns
Asynchronous reset recovery time	T_{RSTREC}	0.004		0.005		ns
Asynchronous reset minimum pulse width	T_{RSTMPW}	0.301		0.354		ns
Pipelined register asynchronous reset removal time	$T_{PLRSTREM}$	–0.279		–0.328		ns
Pipelined register asynchronous reset recovery time	$T_{PLRSTREC}$	0.327		0.385		ns
Pipelined register asynchronous reset minimum pulse width	$T_{PLRSTMPW}$	0.282		0.332		ns
Synchronous reset setup time	T_{SRSTSU}	0.226		0.265		ns
Synchronous reset hold time	T_{SRSTHD}	0.036		0.043		ns
Write enable setup time	T_{WESU}	0.454		0.534		ns
Write enable hold time	T_{WEHD}	0.048		0.057		ns
Maximum frequency	F_{MAX}		400		340	MHz

Table 238 • μ SRAM (RAM64x16) in 64 x 16 Mode (continued)

Parameter	Symbol	-1		-Std		Unit
		Min	Max	Min	Max	
Read synchronous reset hold time	T_{SRSTHD}	0.061		0.071		ns
Write clock period	T_{CCY}	4		4		ns
Write clock minimum pulse width high	$T_{CCLKMPWH}$	1.8		1.8		ns
Write clock minimum pulse width low	$T_{CCLKMPWL}$	1.8		1.8		ns
Write block setup time	T_{BLKCSU}	0.404		0.476		ns
Write block hold time	T_{BLKCHD}	0.007		0.008		ns
Write input data setup time	T_{DINCSU}	0.115		0.135		ns
Write input data hold time	T_{DINCHD}	0.15		0.177		ns
Write address setup time	$T_{ADDRCSU}$	0.088		0.104		ns
Write address hold time	$T_{ADDRCHD}$	0.128		0.15		ns
Write enable setup time	T_{WECSU}	0.397		0.467		ns
Write enable hold time	T_{WECHD}	-0.026		-0.03		ns
Maximum frequency	F_{MAX}		250		250	MHz

The following table lists the μ SRAM in 128 x 9 mode in worst commercial-case conditions when $T_J = 85^\circ\text{C}$, $V_{DD} = 1.14\text{ V}$.

Table 239 • μ SRAM (RAM128x9) in 128 x 9 Mode

Parameter	Symbol	-1		-Std		Unit
		Min	Max	Min	Max	
Read clock period	T_{CY}	4		4		ns
Read clock minimum pulse width high	$T_{CLKMPWH}$	1.8		1.8		ns
Read clock minimum pulse width low	$T_{CLKMPWL}$	1.8		1.8		ns
Read pipeline clock period	T_{PLCY}	4		4		ns
Read pipeline clock minimum pulse width high	$T_{PLCLKMPWH}$	1.8		1.8		ns
Read pipeline clock minimum pulse width low	$T_{PLCLKMPWL}$	1.8		1.8		ns
Read access time with pipeline register	T_{CLK2Q}		0.266		0.313	ns
Read access time without pipeline register				1.677		1.973
Read address setup time in synchronous mode	T_{ADDRSU}	0.301		0.354		ns
Read address setup time in asynchronous mode			1.856		2.184	
Read address hold time in synchronous mode	T_{ADDRHD}	0.091		0.107		ns
Read address hold time in asynchronous mode			-0.778		-0.915	
Read enable setup time	T_{RDENSU}	0.278		0.327		ns
Read enable hold time	T_{RDENHD}	0.057		0.067		ns
Read block select setup time	T_{BLKSU}	1.839		2.163		ns
Read block select hold time	T_{BLKHD}	-0.65		-0.765		ns
Read block select to out disable time (when pipelined register is disabled)	T_{BLK2Q}		2.036		2.396	ns

The following table lists the programming times in worst-case conditions when $T_J = 100\text{ }^\circ\text{C}$, $V_{DD} = 1.14\text{ V}$. External SPI flash part# AT25DF641-s3H is used during this measurement.

Table 256 • JTAG Programming (Fabric Only)

M2S/M2GL Device	Image size		Verify	Unit
	Bytes	Program		
005	302672	44	10	Sec
010	568784	50	18	Sec
025	1223504	73	26	Sec
050	2424832	88	54	Sec
060	2418896	99	54	Sec
090	3645968	135	126	Sec
150	6139184	177	193	Sec

Table 257 • JTAG Programming (eNVM Only)

M2S/M2GL Device	Image size		Verify	Unit
	Bytes	Program		
005	137536	61	4	Sec
010	274816	100	9	Sec
025	274816	100	9	Sec
050	2,78,528	106	8	Sec
060	268480	98	8	Sec
090	544496	176	15	Sec
150	544496	177	15	Sec

Table 258 • JTAG Programming (Fabric and eNVM)

M2S/M2GL Device	Image size		Verify	Unit
	Bytes	Program		
005	439296	71	11	Sec
010	842688	129	20	Sec
025	1497408	142	35	Sec
050	2695168	184	59	Sec
060	2686464	180	70	Sec
090	4190208	288	147	Sec
150	6682768	338	231	Sec

Table 259 • 2 Step IAP Programming (Fabric Only)

M2S/M2GL Device	Image size		Authenticate	Program	Verify	Unit
	Bytes					
005	302672	4	39	6	Sec	
010	568784	7	45	12	Sec	
025	1223504	14	55	23	Sec	
050	2424832	29	74	40	Sec	
060	2418896	39	83	50	Sec	
090	3645968	60	106	73	Sec	
150	6139184	100	154	120	Sec	

Table 260 • 2 Step IAP Programming (eNVM Only)

M2S/M2GL Device	Image size		Authenticate	Program	Verify	Unit
	Bytes					
005	137536	2	59	5	Sec	
010	274816	4	98	11	Sec	
025	274816	4	100	10	Sec	
050	2,78,528	3	107	9	Sec	
060	268480	5	98	22	Sec	
090	544496	10	174	43	Sec	
150	544496	10	175	44	Sec	

Table 261 • 2 Step IAP Programming (Fabric and eNVM)

M2S/M2GL Device	Image size		Authenticate	Program	Verify	Unit
	Bytes					
005	439296	6	78	11	Sec	
010	842688	11	122	21	Sec	
025	1497408	19	135	32	Sec	
050	2695168	32	158	48	Sec	
060	2686464	43	159	70	Sec	
090	4190208	68	258	115	Sec	
150	6682768	109	308	162	Sec	

Table 276 • Cryptographic Block Characteristics (continued)

Service	Conditions	Timing	Unit
SHA256	512 bits	540	kbps
	1024 bits	780	kbps
	2048 bits	950	kbps
	24 kbits	1140	kbps
HMAC	512 bytes	820	kbps
	1024 bytes	890	kbps
	2048 bytes	930	kbps
	24 kbytes	980	kbps
KeyTree		1.8	ms
Challenge-response	PUF = OFF	25	ms
	PUF = ON	7	ms
ECC point multiplication		590	ms
ECC point addition		8	ms

1. Using cypher block chaining (CBC) mode.

2.3.19 Crystal Oscillator

The following table describes the electrical characteristics of the crystal oscillator in the IGLOO2 FPGA and SmartFusion2 SoC FPGAs.

Table 277 • Electrical Characteristics of the Crystal Oscillator – High Gain Mode (20 MHz)

Parameter	Symbol	Min	Typ	Max	Unit	Condition
Operating frequency	FXTAL		20		MHz	
Accuracy	ACCXTAL			0.0047	%	005, 010, 025, 050, 060, and 090 devices
				0.0058	%	150 devices
Output duty cycle	CYCXTAL		49–51	47–53	%	
Output period jitter (peak to peak)	JITPERXTAL		200	300	ps	
Output cycle to cycle jitter (peak to peak)	JITCYCXTAL		200	300	ps	010, 025, 050, and 060 devices
			250	410	ps	150 devices
			250	550	ps	005 and 090 devices
Operating current	IDYNXTAL		1.5		mA	010, 050, and 060 devices
			1.65		mA	005, 025, 090, and 150 devices
Input logic level high	VIHXTAL	0.9 V _{PP}			V	
Input logic level low	VILXTAL			0.1 V _{PP}	V	

Table 293 • Flash*Freeze Entry and Exit Times (continued)

Parameter	Symbol	Entry/Exit Timing FCLK = 100MHz			Entry/Exit Timing FCLK = 3 MHz	
		005, 010, 025, 060, 090, and 150	050	All Devices	Unit	Conditions
Exit time with respect to the fabric PLL lock ¹	TFF_EXIT	1.5	1.5	1.5	ms	eNVM and MSS/HPMS PLL = ON during F*F
		1.5	1.5	1.5	ms	eNVM and MSS/HPMS PLL = OFF during F*F and both are turned back on at exit
Exit time with respect to the fabric buffer output	TFF_EXIT	21	15	21	µs	eNVM and MSS/HPMS PLL = ON during F*F
		65	55	65	µs	eNVM and MSS/HPMS PLL = OFF during F*F and both are turned back on at exit

1. PLL Lock Delay set to 1024 cycles (default).

2.3.28 DDR Memory Interface Characteristics

The following table lists the DDR memory interface characteristics in worst-case industrial conditions when T_J = 100 °C, V_{DD} = 1.14 V.

Table 294 • DDR Memory Interface Characteristics

Standard	Supported Data Rate		Unit
	Min	Max	
DDR3	667	667	Mbps
DDR2	667	667	Mbps
LPDDR	50	400	Mbps

2.3.29 SFP Transceiver Characteristics

IGLOO2 and SmartFusion2 SerDes complies with small form-factor pluggable (SFP) requirements as specified in SFP INF-80741. The following table provides the electrical characteristics.

The following table lists the SFP transceiver electrical characteristics in worst-case industrial conditions when T_J = 100 °C, V_{DD} = 1.14 V.

Table 295 • SFP Transceiver Electrical Characteristics

Pin	Direction	Differential Peak-Peak Voltage		Unit
		Min	Max	
RD+/- ¹	Output	1600	2400	mV
TD+/- ²	Input	350	2400	mV

1. Based on default SerDes transmitter settings for PCIe Gen1. Lower amplitudes are available through programming changes to TX_AMP setting.
2. Based on Input Voltage Common-Mode (VICM) = 0 V. Requires AC Coupling.

2.3.30 SerDes Electrical and Timing AC and DC Characteristics

PCIe is a high-speed, packet-based, point-to-point, low-pin-count, serial interconnect bus. The IGLOO2 and SmartFusion2 SoC FPGAs has up to four hard high-speed serial interface blocks. Each SerDes block contains a PCIe system block. The PCIe system is connected to the SerDes block.

The following table lists the transmitter parameters in worst-case industrial conditions when $T_J = 100\text{ }^\circ\text{C}$, $V_{DD} = 1.14\text{ V}$.

Table 296 • Transmitter Parameters

Symbol	Description	Min	Max	Unit
VTX-DIFF-PP	Differential swing (2.5 Gbps, 5.0 Gbps)	0.8	1.2	V
VTX-CM-AC-P	Output common mode voltage (2.5 Gbps)		20	mV
VTX-CM-AC-PP	Output common mode voltage (5.0 Gbps)		100	mV
VTX-RISE-FALL	Rise and fall time (20% to 80%, 2.5 Gbps)	0.125		UI
	Rise and fall time (20% to 80%, 5.0 Gbps)	0.15		UI
ZTX-DIFF-DC	Output impedance–differential	80	120	Ω
LTX-SKEW	Lane-to-lane TX skew within a SerDes block (2.5 Gbps)		500 ps + 2 UI	ps
	Lane-to-lane TX skew within a SerDes block (5.0 Gbps)		500 ps + 4 UI	ps
RLTX-DIFF	Return loss differential mode (2.5 Gbps)	–10		dB
	Return loss differential mode (5.0 Gbps) 0.05 GHz to 1.25 GHz	–10		dB
	1.25 GHz to 2.5 GHz	–8		dB
RLTX-CM	Return loss common mode (2.5 Gbps, 5.0 Gbps)	–6		dB
TX-LOCK-RST	Transmit PLL lock time from reset		10	μs
VTX-AMP	100 mV setting	90	150	mV
	400 mV setting	320	480	mV
	800 mV setting	660	940	mV
	1200 mV setting	950	1400	mV

2.3.34 MMUART Characteristics

The following table lists the MMUART characteristics in worst-case industrial conditions when $T_J = 100\text{ }^\circ\text{C}$, $V_{DD} = 1.14\text{ V}$.

Table 308 • MMUART Characteristics

Parameter	Description	-1	-Std	Unit
FMMUART_REF_CLK	Internally sourced MMUART reference clock frequency.	166	142	MHz
BAUDMMUARTTx	Maximum transmit baud rate	10.375	8.875	Mbps
BAUDMMUARTRx	Maximum receive baud rate	10.375	8.875	Mbps

2.3.35 IGLOO2 Specifications

2.3.35.1 HPMS Clock Frequency

The following table lists the maximum frequency for HPMS main clock in worst-case industrial conditions when $T_J = 100\text{ }^\circ\text{C}$, $V_{DD} = 1.14\text{ V}$.

Table 309 • Maximum Frequency for HPMS Main Clock

Symbol	Description	-1	-Std	Unit
HPMS_CLK	Maximum frequency for the HPMS main clock	166	142	MHz

2.3.35.2 IGLOO2 Serial Peripheral Interface (SPI) Characteristics

This section describes the DC and switching of the SPI interface. Unless otherwise noted, all output characteristics given are for a 35 pF load on the pins and all sequential timing characteristics are related to SPI_0_CLK. For timing parameter definitions, see [Figure 23](#), page 131.

The following table lists the SPI characteristics in worst-case industrial conditions when $T_J = 100\text{ }^\circ\text{C}$, $V_{DD} = 1.14\text{ V}$.

Table 310 • SPI Characteristics for All Devices

Symbol	Description	Min	Typ	Max	Unit	Conditions
SPIFMAX	Maximum operating frequency of SPI interface			20	MHz	
sp1	SPI_[0 1]_CLK minimum period					
	SPI_[0 1]_CLK = PCLK/2	12			ns	
	SPI_[0 1]_CLK = PCLK/4	24.1			ns	
	SPI_[0 1]_CLK = PCLK/8	48.2			ns	
	SPI_[0 1]_CLK = PCLK/16	0.1			μs	
	SPI_[0 1]_CLK = PCLK/32	0.19			μs	
	SPI_[0 1]_CLK = PCLK/64	0.39			μs	
SPI_[0 1]_CLK = PCLK/128	0.77			μs		