



Welcome to [E-XFL.COM](https://www.e-xfl.com)

Understanding [Embedded - Microcontroller, Microprocessor, FPGA Modules](#)

Embedded - Microcontroller, Microprocessor, and FPGA Modules are fundamental components in modern electronic systems, offering a wide range of functionalities and capabilities. Microcontrollers are compact integrated circuits designed to execute specific control tasks within an embedded system. They typically include a processor, memory, and input/output peripherals on a single chip. Microprocessors, on the other hand, are more powerful processing units used in complex computing tasks, often requiring external memory and peripherals. FPGAs (Field Programmable Gate Arrays) are highly flexible devices that can be configured by the user to perform specific logic functions, making them invaluable in applications requiring customization and adaptability.

Applications of [Embedded - Microcontroller,](#)

Details

Product Status	Obsolete
Module/Board Type	MCU, FPGA
Core Processor	ARM Cortex-A9
Co-Processor	Zynq-7000 (Z-7020)
Speed	-
Flash Size	32MB
RAM Size	1GB
Connector Type	Samtec LSHM
Size / Dimension	1.97" x 1.57" (50mm x 40mm)
Operating Temperature	-40°C ~ 85°C
Purchase URL	https://www.e-xfl.com/product-detail/trenz-electronic/te0720-03-2ifc3

1 Table of Contents

1	Table of Contents.....	2
2	Overview.....	4
2.1	Key Features.....	4
2.2	Block Diagram.....	5
2.3	Main Components.....	6
2.4	Initial Delivery State.....	7
3	Boot Process.....	8
4	Signals, Interfaces and Pins.....	9
4.1	Board to Board (B2B) I/Os.....	9
4.2	JTAG Interface.....	10
4.3	System Controller CPLD I/O Pins.....	10
4.4	Quad SPI Interface.....	11
4.5	eMMC Interface.....	11
4.6	Ethernet Interface.....	12
4.7	USB Interface.....	13
4.8	I2C Interface.....	14
5	On-board Peripherals.....	16
5.1	System Controller CPLD.....	16
5.2	DDR Memory.....	16
5.3	Quad SPI Flash Memory.....	16
5.4	eMMC Flash Memory.....	16
5.5	Gigabit Ethernet PHY.....	17
5.6	High-speed USB ULPI PHY.....	17
5.7	RTC - Real Time Clock.....	17
5.8	MAC-Address EEPROM.....	18
5.9	Atmel CryptoAuthentication Chip.....	18
5.10	eCompass module.....	18
5.11	Oscillators.....	18
5.12	On-board LEDs.....	19
6	Power and Power-On Sequence.....	20

6.1	Power Supply	20
6.2	Power-On Sequence	20
6.3	Power Rails	21
6.4	Bank Voltages	22
7	Board to Board Connectors	24
7.1	Connector Mating height	24
7.2	Connector Speed Ratings	24
7.3	Current Rating	25
7.4	Connector Mechanical Ratings	25
7.5	Manufacturer Documentation	25
8	Variants Currently in Production	26
9	Technical Specifications	27
9.1	Absolute Maximum Ratings	27
9.2	Recommended Operating Conditions	28
9.3	Operating Temperature Ranges	28
9.4	Physical Dimensions	28
10	Revision History	30
10.1	Hardware Revision History	30
10.2	Document Change History	30
11	Disclaimer	31
11.1	Document Warranty	31
11.2	Limitation of Liability	31
11.3	Copyright Notice	31
11.4	Technology Licenses	31
11.5	Environmental Protection	31
11.6	REACH, RoHS and WEEE	32

2 Overview

Refer to <https://wiki.trenz-electronic.de/display/PD/TE0720+TRM> for online version of this manual and additional technical documentation of the product.

The Trenz Electronic TE0720 is an industrial-grade SoM (System on Module) based on [Xilinx Zynq-7000 SoC](#) (XC7Z020 or XC7Z014S) with up to 1 GB of DDR3/L SDRAM, 32MB of SPI flash memory, Gigabit Ethernet PHY transceiver, a USB PHY transceiver and powerful switching-mode power supplies for all on-board voltages. A large number of configurable I/Os is provided via rugged high-speed stacking strips. See also Variants Currently in Production section.

2.1 Key Features

- Xilinx XC7Z SoC (XC7Z020 or XC7Z014S)
 - Processing system (PS):
 - XC7Z020: Dual-core ARM Cortex-A9 MPCore™ with CoreSight™
 - XC7Z014S: Single-core ARM Cortex-A9 MPCore™ with CoreSight™
 - L1 cache: 32 KByte instruction, 32 KByte data per processor
 - L2 cache: Unified 512 KByte
 - Programmable logic (PL): Artix-7 FPGA
 - Programmable logic cells: 85K (XC7Z020), 65K (XC7Z014S)
 - Block RAM: 4.9 MByte (XC7Z020), 3.8 MByte (XC7Z014S)
 - DSP slices: 220 (XC7Z020), 170 (XC7Z014S)
 - Peak DSP performance: 276 GMACs (XC7Z020), 187 GMACs (XC7Z014S)
 - 2x 12 bit, MSPS ADCs with up to 17 differential inputs
- 54 multiuse I/O (MIO) pins
- 152 High-Range (HR) I/O pins (SelectIO interfaces)
- System Controller CPLD ([Lattice LCMXO2-1200HC](#))
- Up to 1 GByte DDR3/L SDRAM memory (2 x 256 Mbit x 16, 32-bit wide data bus).
- 32 MByte Quad SPI Flash memory
- Gigabit Ethernet transceiver PHY ([Marvell 88E1512](#))
- MAC address serial EEPROM with EUI-48™ node identity ([11AA02E48](#))
- Highly integrated full-featured hi-speed USB 2.0 ULPI transceiver ([Microchip USB3320C-EZK](#))
- 3-axis accelerometer and 3-axis magnetometer ([ST Microelectronics LSM303DTR](#)) (Optional!)
- Real time clock with embedded crystal ([Intersil ISL12020M](#)): ±5ppm accuracy
- Atmel CryptoAuthentication element ([Atmel ATSHA204A](#))
- Up to 32 GByte eMMC, usually 4 GByte, depends on module variant and assembly option
- User LED 1 (Green), user LED 2 (Red), user LED 3 - FPGA DONE (Green)
- On-board high-efficiency DC-DC converters for all voltages used
- Trenz 4 x 5 module socket connectors (3 x [Samtec LSHM series connectors](#))

- Evenly spread supply pins for good signal integrity
- Rugged for shock and high vibration

Additional assembly options are available for cost or performance optimization upon request.

2.2 Block Diagram

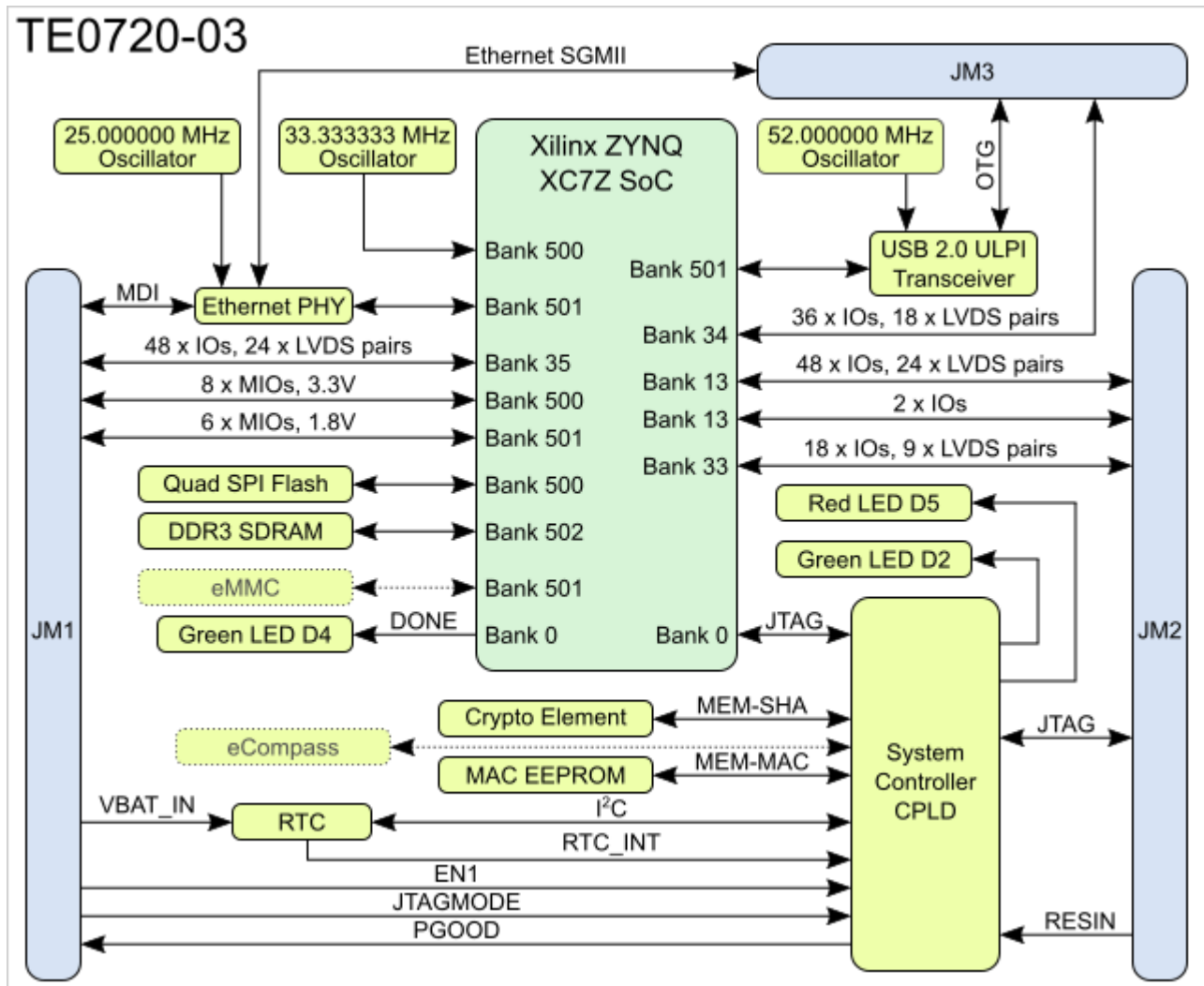

Figure 1: TE0720-03 block diagram.

Components and connections marked with dashed lines are optional or may be missing on some module variants, please contact us for additional information.

2.3 Main Components

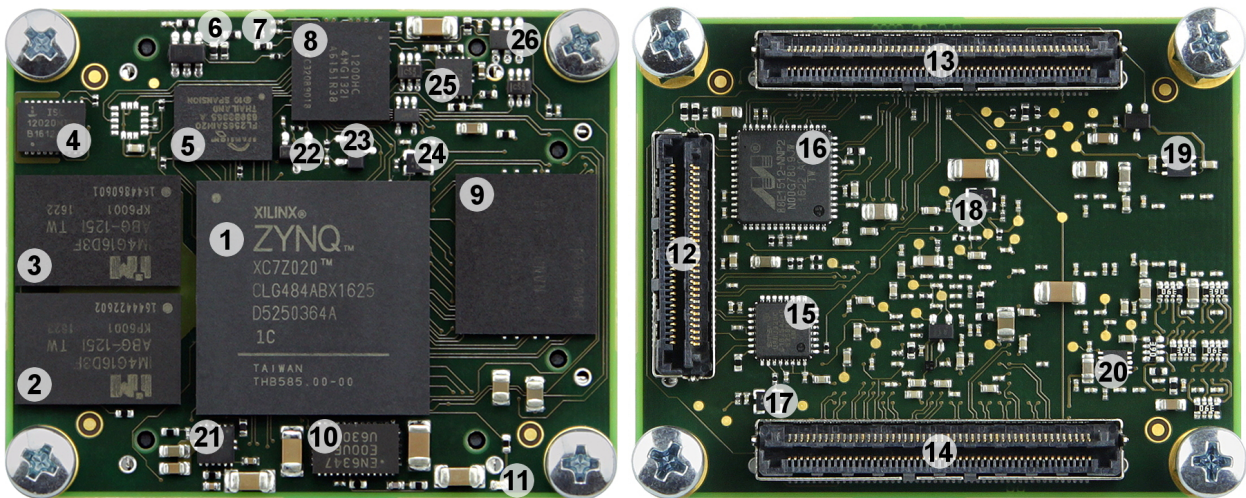

Figure 2: Main components of the module.

1. Xilinx Zynq XC7Z SoC, U5
2. 4 Gbit DDR3/L SDRAM, U13
3. 4 Gbit DDR3/L SDRAM, U12
4. Low-power RTC with battery backed SRAM, U20
5. 32 MByte Quad SPI Flash memory, U7
6. Red LED (LED1), D5
7. Green LED (LED2), D2
8. System Controller CPLD, U19
9. eMMC NAND Flash, U15
10. 4A high-efficiency PowerSoC DC-DC step-down converter (1V), U1
11. Green LED (DONE), D4
12. B2B connector Samtec Razor Beam™ LSHM-130, JM3
13. B2B connector Samtec Razor Beam™ LSHM-150, JM1
14. B2B connector Samtec Razor Beam™ LSHM-150, JM2
15. Hi-speed USB 2.0 ULPI transceiver, U18
16. Gigabit Ethernet (GbE) transceiver, U8
17. Low-power programmable oscillator @ 52.000000 MHz (OTG-RCLK), U14
18. Low-power programmable oscillator @ 33.333333 MHz (PS-CLK), U6
19. Low-dropout regulator (VBATT), U24
20. DDR termination regulator, U4
21. 1.5A PowerSoC DC-DC step-down converter with integrated inductor (1.5V), U2
22. Atmel CryptoAuthentication chip, U10
23. 2Kbit UNI/O® serial EEPROM with EUI-48™ node identity, U17
24. Low-power programmable oscillator @ 25.000000 MHz (ETH-CLK), U9
25. 1.5A PowerSoC DC-DC step-down converter with integrated inductor (1.8V), U3
26. 3A PFET load switch with configurable slew rate (3.3V), Q1

3 Boot Process

By default the TE-0720 supports QSPI and SD Card boot modes which is controlled by the MODE input signal from the B2B JM1 connector.

MODE Signal State	Boot Mode
High or open	QSPI
Low or connected to the ground	SD Card

Table 14: Boot modes.

4 Signals, Interfaces and Pins

4.1 Board to Board (B2B) I/Os

PL I/O signal connections between Zynq SoC's I/O banks and B2B connectors, 152 HR GPIOs total.

Bank	Type	Voltage	B2B	I/O Count	Notes
13	HR GPIO	VCCIO13	JM2	48	24 LVDS pairs
13	HR GPIO	VCCIO13	JM2	2	B13_IO0 and B13_IO25
33	HR GPIO	VCCIO33	JM2	18	9 LVDS pairs
34	HR GPIO	VCCIO34	JM3	36	18 LVDS pairs
35	HR GPIO	VCCIO35	JM1	48	24 LVDS pairs

Table 2: General PL I/O to B2B connectors information.

PS MIO bank 500 and 501 signal connections to B2B JM1 connector, 14 PS MIOs total.

MIO	B2B Pin	Bank	Voltage	Notes
0	JM1-87	500	3.3V	
9	JM1-91	500	3.3V	
10	JM1-95	500	3.3V	
11	JM1-93	500	3.3V	
12	JM1-99	500	3.3V	
13	JM1-97	500	3.3V	
14	JM1-92	500	3.3V	Also wired to U19-M4
15	JM1-85	500	3.3V	Also wired to U19-N4
40	JM1-27	501	1.8V	Zynq SoC SD0
41	JM1-25	501	1.8V	Zynq SoC SD0
42	JM1-23	501	1.8V	Zynq SoC SD0
43	JM1-21	501	1.8V	Zynq SoC SD0

44	JM1-19	501	1.8V	Zynq SoC SD0
45	JM1-17	501	1.8V	Zynq SoC SD0

Table 3: General PS MIO connections information.

For detailed information about the pin-out, please refer to the [Pin-out tables](#).

4.2 JTAG Interface

JTAG access to the Zynq SoC and System Controller CPLD is provided through B2B connector JM2.

JTAG Signal	B2B Connector Pin
TMS	JM2-93
TDI	JM2-95
TDO	JM2-97
TCK	JM2-99

Table 4: JTAG pins connection.

 JTAGMODE pin 89 in B2B connector JM1 is used to switch access between devices, low selects Zynq SoC, high selects System Controller CPLD.

4.3 System Controller CPLD I/O Pins

Special purpose pins are connected to System Controller CPLD and have following default configuration:

Pin Name	Mode	Function	Default Configuration
RESIN	Input	Reset input	Active low reset input, default mapping forces POR_B reset to Zynq PS.
PGOOD	Output	Power good	Active high when all on-module power supplies are working properly.
MODE	Input	Boot mode	Force low for boot from the SD card. Latched at power-on only, not during soft reset!

EN1	Input	Power enable	High enables the DC-DC converters and on-board supplies. Not used if NOSEQ is high.
NOSEQ	Input	Power sequencing	Forces the 1.0V and 1.8V DC-DC converters always ON when high.
JTAG MODE	Input	JTAG select	Keep low for FPGA JTAG access.
MIO7	Input/Output	GPIO	Connected to System Controller CPLD pin P11, function depends on firmware

Table 5: System Controller CPLD special purpose pins description.

4.4 Quad SPI Interface

Quad SPI Flash (U7) is connected to the Zynq PS QSPI0 interface via PS MIO bank 500, pins MIO1..6.

MIO	Signal Name	U7 Pin
1	SPI-CS	C2
2	SPI-DQ0/M0	D3
3	SPI-DQ1/M1	D2
4	SPI-DQ2/M2	C4
5	SPI-DQ3/M3	D4
6	SPI-SCK/M4	B2

Table 6: Quad SPI interface MIOs and pins.

4.5 eMMC Interface

The TE0720 has on-board eMMC memory device (U15) except TE0720-03-1CR variant. At least three different eMMC devices have been used, please contact Trenz Electronic for more specific information.

MIO	Signal Name	U15 Pin
46	MMC-D0	H3
47	MMC-CMD	W5

ETH-TXD3	20		ETH-RXD3	26
ETH-TXCTL	21		ETH-RXCTL	27
ETH-MDC	52		ETH-MDIO	53

Table 9: Ethernet PHY to Zynq SoC connections.

4.7 USB Interface

Hi-speed USB ULPI PHY is provided by USB3320 from Microchip (U18). The ULPI interface is connected to the Zynq SoC PS USB0 via MIO28..39, bank 501.

USB PHY Signal	Wired to	SoC MIO
OTG-DATA4	U18-7	28
OTG-DIR	U18-31	29
OTG-STP	U18-29	30
OTG-NXT	U18-2	31
OTG-DATA0	U18-3	32
OTG-DATA1	U18-4	33
OTG-DATA2	U18-5	34
OTG-DATA3	U18-6	35
OTG-CLK	U18-1	36
OTG-DATA5	U18-9	37
OTG-DATA6	U18-10	38
OTG-DATA7	U18-13	39

Table 10: USB ULPI PHY to Zynq SoC connections.

USB PHY connection

I ² C Device	I ² C Address	IC	Notes
ISL12020M RTC	0x6F	U20	RTC registers.
ISL12020M SRAM	0x57	U20	Battery backed RAM in RTC IC.
LSM303D	0x1D	U22	Optional, not soldered on current production variants.

Table 13: I²C slave device addresses.

5 On-board Peripherals

5.1 System Controller CPLD

The System Controller CPLD (U19) is provided by Lattice Semiconductor LCMXO2-1200HC (MachXO2 product family). The System Controller CPLD is the central system management unit where essential control signals are logically linked by the implemented logic in System Controller CPLD firmware, which generates output signals to control the system, the on-board peripherals and the interfaces. Also interfaces like JTAG and I²C between the on-board peripherals and to the Zynq SoC are by-passed, forwarded and controlled.

Other tasks of the System Controller CPLD are monitoring of the power-on sequence and to indicate the programming state of the Zynq SoC FPGA.

For more detailed information, refer to the TE0720 System Controller CPLD firmware page.

5.2 DDR Memory

By default TE0720 module has two DDR3/L SDRAM chips arranged into 32-bit wide memory bus providing total on-board memory size up to 1 GBytes. Size of memory depends on the module variant, refer to the variants table.

5.3 Quad SPI Flash Memory

On-board 32-MByte QSPI flash memory S25FL256S (U7) is used to store initial FPGA configuration. Besides FPGA configuration, remaining free flash memory can be used for user application and data storage. All four SPI data lines are connected to the FPGA allowing x1, x2 or x4 data bus widths. Maximum data rate depends on the selected bus width and clock frequency used.

 SPI Flash QE (Quad Enable) bit must be set to high or FPGA is unable to load its configuration from flash during power-on. By default this bit is set to high at the manufacturing plant.

5.4 eMMC Flash Memory

eMMC Flash memory device(U15) is connected to the Zynq PS MIO bank 501 pins MIO46..MIO51 (see also [Variants Currently in Production](#) for options). Depending on the module variant, different make and model of eMMC chips are available.

5.5 Gigabit Ethernet PHY

On-board Gigabit Ethernet PHY is provided with Marvell Alaska 88E1512 IC (U8). The Ethernet PHY RGMII interface is connected to the Zynq Ethernet0 PS GEM0. I/O voltage is fixed at 1.8V for HSTL signalling. The reference clock input of the PHY is supplied from an on-board 25.000000 MHz oscillator (U9), the 125MHz output clock signal CLK_125MHZ is connected to the pin G13 of the System Controller CPLD chip (U19).

PHY Signal	SC CPLD Pin
ETH-MDC	L14
ETH-MDIO	K14
PHY_LED0	F14
PHY_LED1	D12
PHY_LED2	C13
PHY_CONFIG	C14
ETH-RST	E14
CLK_125MHZ	G13

Table 15: Ethernet PHY to SC CPLD connections.

5.6 High-speed USB ULPI PHY

Hi-speed USB ULPI PHY is provided with USB3320 from Microchip. The ULPI interface is connected to the Zynq PS USB0 via MIO28..39, bank 501 (see also section. The I/O voltage is fixed at 1.8V and PHY reference clock input is supplied from the on-board 52.000000 MHz oscillator (U14).

5.7 RTC - Real Time Clock

Temperature compensated Intersil ISL12020M IC is used for Real Time Clock (U20). Battery voltage must be supplied to the module VBAT_IN pin from the carrier board to use battery backed functionality. Battery backed registers can be accessed over I²C bus at slave address of 0x6F. General purpose RAM is at I²C slave address 0x57. RTC IC is supported by Linux so it can be used as *hwclock* device.

5.8 MAC-Address EEPROM

A Microchip 2Kbit 11AA02E48 serial EEPROM (U17) is connected to the System Controller CPLD pin M14 via single-I/O UNI/O serial interface and contains pre-programmed globally unique 48-bit node address compatible with EUI-48™ specification. Chip is programmed at the factory with a globally unique node address stored in the upper 1/4 of the memory array and write-protected through the STATUS register. The remaining 1,536 bits are available for application use.

5.9 Atmel CryptoAuthentication Chip

The ATSHA204A Atmel CryptoAuthentication™ chip (U10) is connected to the System Controller CPLD pin N14 via single-wire interface providing various security functions and features such as anti-counterfeiting, firmware/media protection, password validation, secure session key exchanging, secure data storage and more. Refer to the product datasheet for more information.

5.10 eCompass module

Optionally TE0720 module can be fitted with ultra-compact high-performance eCompass device (LSM303D, U22) featuring 3D accelerometer and 3D magnetometer.

5.11 Oscillators

Source	Signal	Frequency	Destination	Pin Name	Notes
U6	PS-CLK	33.333333 MHz	U5	PS_CLK_500	Zynq SoC PS subsystem main clock.
U14	OTG-RCLK	52.000000 MHz	U18	REFCLK	USB3320C PHY reference clock.
U9	ETH-CLK	25.000000 MHz	U8	XTAL_IN	88E1512 PHY reference clock.

Table 16: Oscillators.

5.12 On-board LEDs

LED	Color	Connected to	Description and Notes
D2	Green	LED1	Controlled by System Controller CPLD firmware.
D4	Green	DONE	
D5	Red	LED2	Controlled by System Controller CPLD firmware.

Table 17: On-board LEDs.

6 Power and Power-On Sequence

6.1 Power Supply

Power supply with minimum current capability of 3A for system startup is recommended.

Power Consumption

Power Input Pin	Typical Current
VIN	TBD*
3.3VIN	TBD*

Table 18: Power Consumption.

* TBD - To Be Determined.

Power Distribution Diagram

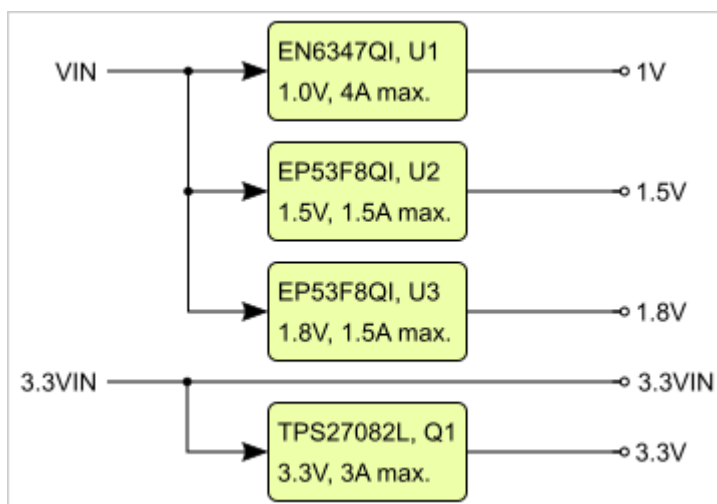

Figure 3: Power distribution diagram.

⚠ Current rating of Samtec Razor Beam™ LSHM B2B connectors is 2.0A per pin (2 adjacent pins powered).

6.2 Power-On Sequence

For highest efficiency of the on-board DC-DC regulators, it is recommended to use single 3.3V power source for both VIN and 3.3VIN power rails. Although VIN and 3.3VIN can be powered up in any order, it is recommended to power them up simultaneously.

7 Board to Board Connectors

⚠ These connectors are hermaphroditic. Odd pin numbers on the module are connected to even pin numbers on the baseboard and vice versa.

4 x 5 modules use two or three [Samtec Razor Beam LSHM connectors](#) on the bottom side.

- 2 x REF-189016-02 (compatible to LSHM-150-04.0-L-DV-A-S-K-TR), (100 pins, "50" per row)
- 1 x REF-189017-02 (compatible to LSHM-130-04.0-L-DV-A-S-K-TR), (60 pins, "30" per row) (depending on module)

7.1 Connector Mating height

When using the same type on baseboard, the mating height is 8mm. Other mating heights are possible by using connectors with a different height

Connector on baseboard	compatible to	Mating height
REF-189016-01	LSHM-150-02.5-L-DV-A-S-K-TR	6.5 mm
LSHM-150-03.0-L-DV-A-S-K-TR	LSHM-150-03.0-L-DV-A-S-K-TR	7.0 mm
REF-189016-02	LSHM-150-04.0-L-DV-A-S-K-TR	8.0 mm
LSHM-150-06.0-L-DV-A-S-K-TR	LSHM-150-06.0-L-DV-A-S-K-TR	10.0mm
REF-189017-01	LSHM-130-02.5-L-DV-A-S-K-TR	6.5 mm
LSHM-130-03.0-L-DV-A-S-K-TR	LSHM-130-03.0-L-DV-A-S-K-TR	7.0 mm
REF-189017-02	LSHM-130-04.0-L-DV-A-S-K-TR	8.0 mm
LSHM-130-06.0-L-DV-A-S-K-TR	LSHM-130-06.0-L-DV-A-S-K-TR	10.0mm

The module can be manufactured using other connectors upon request.

7.2 Connector Speed Ratings

The LSHM connector speed rating depends on the stacking height; please see the following table:

Stacking height	Speed rating
12 mm, Single-Ended	7.5 GHz / 15 Gbps

12 mm, Differential	6.5 GHz / 13 Gbps
5 mm, Single-Ended	11.5 GHz / 23 Gbps
5 mm, Differential	7.0 GHz / 14 Gbps

7.3 Current Rating

Current rating of Samtec Razor Beam™ LSHM B2B connectors is 2.0A per pin (2 adjacent pins powered).

7.4 Connector Mechanical Ratings

- Shock: 100G, 6 ms Sine
- Vibration: 7.5G random, 2 hours per axis, 3 axes total

7.5 Manufacturer Documentation

Geändert

07 04, 2016 by Thorsten Trenz

07 04, 2016 by Thorsten Trenz

07 04, 2016 by Thorsten Trenz

07 04, 2016 by Thorsten Trenz

07 04, 2016 by Thorsten Trenz

07 04, 2016 by Thorsten Trenz

07 04, 2016 by Thorsten Trenz

07 04, 2016 by Thorsten Trenz

07 04, 2016 by Thorsten Trenz

07 04, 2016 by Thorsten Trenz

9.2 Recommended Operating Conditions

Parameter	Min	Max	Units	Reference Document
VIN supply voltage	2.5	5.5	V	EN6347QI and EP53F8QI datasheets.
3.3VIN supply voltage	3.135	3.465	V	3.3V +/- 5%.
Supply voltage for PS MIO banks	1.71	3.465	V	See Xilinx DS187 datasheet.
I/O input voltage for PS MIO banks	-0.20	VCCO_MIO + 0.20	V	See Xilinx DS187 datasheet.
Supply voltage for HR I/Os banks	1.14	3.465	V	See Xilinx DS187 datasheet.
I/O input voltage for HR I/O banks	-0.20	VCCIO + 0.20	V	See Xilinx DS187 datasheet.

Table 23: Recommended operating conditions.

9.3 Operating Temperature Ranges

Commercial grade: 0°C to +70°C.

Industrial and automotive grade: -40°C to +85°C.

Operating temperature range depends also on customer design and cooling solution. Please contact us for options.

9.4 Physical Dimensions

- Module size: 50 mm × 40 mm. Please download the assembly diagram for exact numbers.
- Mating height with standard connectors: 8 mm.
- PCB thickness: 1.6 mm.
- Highest part on PCB: approx. 2.5 mm. Please download the step model for exact numbers.

All dimensions are given in millimeters.

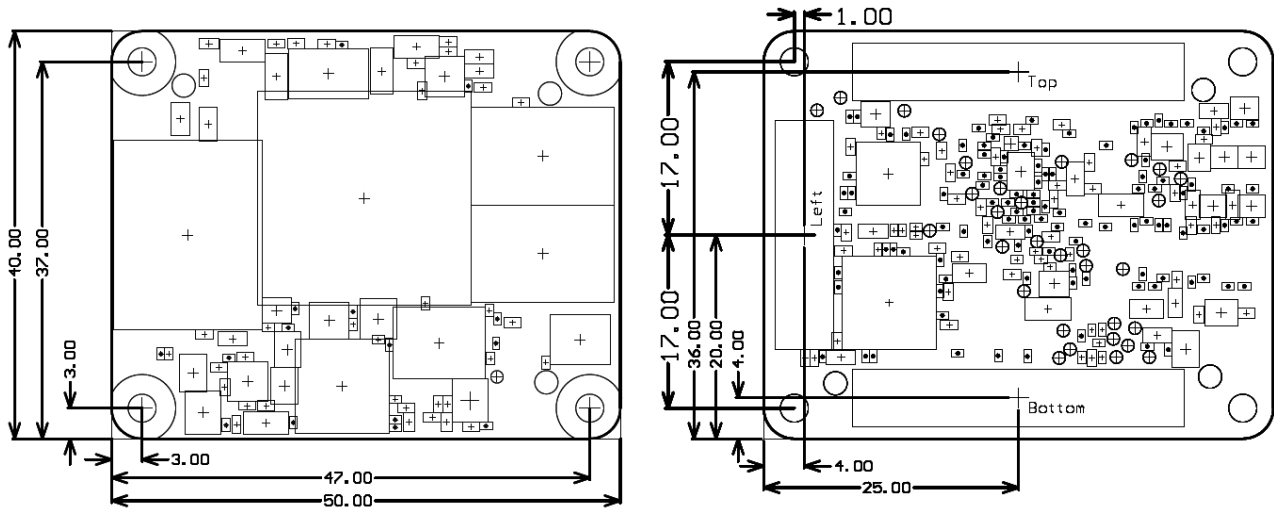

Figure 5: TE0720 module physical dimensions.