

Welcome to [E-XFL.COM](https://www.e-xfl.com)

Understanding Embedded - FPGAs (Field Programmable Gate Array)

Embedded - FPGAs, or Field Programmable Gate Arrays, are advanced integrated circuits that offer unparalleled flexibility and performance for digital systems. Unlike traditional fixed-function logic devices, FPGAs can be programmed and reprogrammed to execute a wide array of logical operations, enabling customized functionality tailored to specific applications. This reprogrammability allows developers to iterate designs quickly and implement complex functions without the need for custom hardware.

Applications of Embedded - FPGAs

The versatility of Embedded - FPGAs makes them indispensable in numerous fields. In telecommunications.

Details

Product Status	Active
Number of LABs/CLBs	-
Number of Logic Elements/Cells	-
Total RAM Bits	147456
Number of I/O	97
Number of Gates	1000000
Voltage - Supply	1.425V ~ 1.575V
Mounting Type	Surface Mount
Operating Temperature	0°C ~ 85°C (Tj)
Package / Case	144-LBGA
Supplier Device Package	144-FPBGA (13x13)
Purchase URL	https://www.e-xfl.com/product-detail/microchip-technology/m7a3p1000-2fg144

I/Os with Advanced I/O Standards

The ProASIC3 family of FPGAs features a flexible I/O structure, supporting a range of voltages (1.5 V, 1.8 V, 2.5 V, and 3.3 V). ProASIC3 FPGAs support many different I/O standards—single-ended and differential.

The I/Os are organized into banks, with two or four banks per device. The configuration of these banks determines the I/O standards supported (Table 1-1).

Table 1-1 • I/O Standards Supported

I/O Bank Type	Device and Bank Location	I/O Standards Supported		
		LVTTTL/ LVCMOS	PCI/PCI-X	LVPECL, LVDS, B-LVDS, M-LVDS
Advanced	East and west Banks of A3P250 and larger devices	✓	✓	✓
Standard Plus	North and south banks of A3P250 and larger devices All banks of A3P060 and A3P125	✓	✓	Not supported
Standard	All banks of A3P015 and A3P030	✓	Not supported	Not supported

Each I/O module contains several input, output, and enable registers. These registers allow the implementation of the following:

- Single-Data-Rate applications
- Double-Data-Rate applications—DDR LVDS, B-LVDS, and M-LVDS I/Os for point-to-point communications

ProASIC3 banks for the A3P250 device and above support LVPECL, LVDS, B-LVDS and M-LVDS. B-LVDS and M-LVDS can support up to 20 loads.

Hot-swap (also called hot-plug, or hot-insertion) is the operation of hot-insertion or hot-removal of a card in a powered-up system.

Cold-sparing (also called cold-swap) refers to the ability of a device to leave system data undisturbed when the system is powered up, while the component itself is powered down, or when power supplies are floating.

Wide Range I/O Support

ProASIC3 devices support JEDEC-defined wide range I/O operation. ProASIC3 supports the JESD8-B specification, covering both 3 V and 3.3 V supplies, for an effective operating range of 2.7 V to 3.6 V.

Wider I/O range means designers can eliminate power supplies or power conditioning components from the board or move to less costly components with greater tolerances. Wide range eases I/O bank management and provides enhanced protection from system voltage spikes, while providing the flexibility to easily run custom voltage applications.

Specifying I/O States During Programming

You can modify the I/O states during programming in FlashPro. In FlashPro, this feature is supported for PDB files generated from Designer v8.5 or greater. See the [FlashPro User's Guide](#) for more information.

Note: PDB files generated from Designer v8.1 to Designer v8.4 (including all service packs) have limited display of Pin Numbers only.

1. Load a PDB from the FlashPro GUI. You must have a PDB loaded to modify the I/O states during programming.
2. From the FlashPro GUI, click PDB Configuration. A FlashPoint – Programming File Generator window appears.
3. Click the Specify I/O States During Programming button to display the Specify I/O States During Programming dialog box.
4. Sort the pins as desired by clicking any of the column headers to sort the entries by that header. Select the I/Os you wish to modify (Figure 1-4 on page 1-8).
5. Set the I/O Output State. You can set Basic I/O settings if you want to use the default I/O settings for your pins, or use Custom I/O settings to customize the settings for each pin. Basic I/O state settings:
 - 1 – I/O is set to drive out logic High

Power Consumption of Various Internal Resources

Table 2-14 • Different Components Contributing to Dynamic Power Consumption in ProASIC3 Devices

Parameter	Definition	Device Specific Dynamic Contributions ($\mu\text{W}/\text{MHz}$)							
		A3P1000	A3P600	A3P400	A3P250	A3P125	A3P060	A3P030	A3P015
PAC1	Clock contribution of a Global Rib	14.50	12.80	12.80	11.00	11.00	9.30	9.30	9.30
PAC2	Clock contribution of a Global Spine	2.48	1.85	1.35	1.58	0.81	0.81	0.41	0.41
PAC3	Clock contribution of a VersaTile row	0.81							
PAC4	Clock contribution of a VersaTile used as a sequential module	0.12							
PAC5	First contribution of a VersaTile used as a sequential module	0.07							
PAC6	Second contribution of a VersaTile used as a sequential module	0.29							
PAC7	Contribution of a VersaTile used as a combinatorial Module	0.29							
PAC8	Average contribution of a routing net	0.70							
PAC9	Contribution of an I/O input pin (standard dependent)	See Table 2-8 on page 2-7 through Table 2-10 on page 2-8.							
PAC10	Contribution of an I/O output pin (standard dependent)	See Table 2-11 on page 2-9 through Table 2-13 on page 2-10.							
PAC11	Average contribution of a RAM block during a read operation	25.00							
PAC12	Average contribution of a RAM block during a write operation	30.00							
PAC13	Dynamic contribution for PLL	2.60							

Note: *For a different output load, drive strength, or slew rate, Microsemi recommends using the Microsemi Power spreadsheet calculator or SmartPower tool in Libero SoC software.

Table 2-39 • Minimum and Maximum DC Input and Output Levels
 Applicable to Standard I/O Banks

3.3 V LVTTTL / 3.3 V LVCMOS	VIL		VIH		VOL	VOH	IOL	IOH	IOSL	IOSH	IIL ¹	IIH ²
	Min V	Max V	Min V	Max V	Max V	Min V	mA	mA	Max mA ³	Max mA ³	μA ⁴	μA ⁴
2 mA	-0.3	0.8	2	3.6	0.4	2.4	2	2	25	27	10	10
4 mA	-0.3	0.8	2	3.6	0.4	2.4	4	4	25	27	10	10
6 mA	-0.3	0.8	2	3.6	0.4	2.4	6	6	51	54	10	10
8 mA	-0.3	0.8	2	3.6	0.4	2.4	8	8	51	54	10	10

Notes:

1. IIL is the input leakage current per I/O pin over recommended operation conditions where $-0.3\text{ V} < V_{IN} < V_{IL}$.
2. IIH is the input leakage current per I/O pin over recommended operating conditions $V_{IH} < V_{IN} < V_{CCI}$. Input current is larger when operating outside recommended ranges
3. Currents are measured at 100°C junction temperature and maximum voltage.
4. Currents are measured at 85°C junction temperature.
5. Software default selection highlighted in gray.

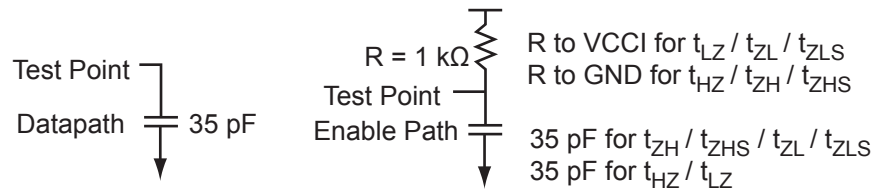
**Figure 2-7 • AC Loading****Table 2-40 • AC Waveforms, Measuring Points, and Capacitive Loads**

Input Low (V)	Input High (V)	Measuring Point* (V)	C _{LOAD} (pF)
0	3.3	1.4	35

Note: *Measuring point = Vtrip. See Table 2-22 on page 2-22 for a complete table of trip points.

Table 2-45 • 3.3 V LVTTTL / 3.3 V LVCMOS High Slew

Commercial-Case Conditions: $T_J = 70^\circ\text{C}$, Worst-Case VCC = 1.425 V, Worst-Case VCCI = 3.0 V
 Applicable to Standard I/O Banks

Drive Strength	Speed Grade	t_{DOUT}	t_{DP}	t_{DIN}	t_{PY}	t_{EOUT}	t_{ZL}	t_{ZH}	t_{LZ}	t_{HZ}	Units
	-2	0.49	3.29	0.03	0.75	0.32	3.36	2.80	1.79	2.01	ns

Notes:

1. Software default selection highlighted in gray.
2. For specific junction temperature and voltage supply levels, refer to Table 2-6 on page 2-6 for derating values.

Table 2-46 • 3.3 V LVTTTL / 3.3 V LVCMOS Low Slew

Commercial-Case Conditions: $T_J = 70^\circ\text{C}$, Worst-Case VCC = 1.425 V, Worst-Case VCCI = 3.0 V
 Applicable to Standard I/O Banks

Drive Strength	Speed Grade	t_{DOUT}	t_{DP}	t_{DIN}	t_{PY}	t_{EOUT}	t_{ZL}	t_{ZH}	t_{LZ}	t_{HZ}	Units
2 mA	Std.	0.66	9.46	0.04	1.00	0.43	9.64	8.54	2.07	2.04	ns
	-1	0.56	8.05	0.04	0.85	0.36	8.20	7.27	1.76	1.73	ns
	-2	0.49	7.07	0.03	0.75	0.32	7.20	6.38	1.55	1.52	ns
4 mA	Std.	0.66	9.46	0.04	1.00	0.43	9.64	8.54	2.07	2.04	ns
	-1	0.56	8.05	0.04	0.85	0.36	8.20	7.27	1.76	1.73	ns
	-2	0.49	7.07	0.03	0.75	0.32	7.20	6.38	1.55	1.52	ns
6 mA	Std.	0.66	6.57	0.04	1.00	0.43	6.69	5.98	2.40	2.57	ns
	-1	0.56	5.59	0.04	0.85	0.36	5.69	5.09	2.04	2.19	ns
	-2	0.49	4.91	0.03	0.75	0.32	5.00	4.47	1.79	1.92	ns
8 mA	Std.	0.66	6.57	0.04	1.00	0.43	6.69	5.98	2.40	2.57	ns
	-1	0.56	5.59	0.04	0.85	0.36	5.69	5.09	2.04	2.19	ns
	-2	0.49	4.91	0.03	0.75	0.32	5.00	4.47	1.79	1.92	ns

Note: For specific junction temperature and voltage supply levels, refer to Table 2-6 on page 2-6 for derating values.

Table 2-58 • Minimum and Maximum DC Input and Output Levels
Applicable to Standard I/O Banks

2.5 V LVC MOS	VIL		VIH		VOL	VOH	IOL	IOH	IOSL	IOSH	IIL ¹	IIH ²
Drive Strength	Min. V	Max., V	Min. V	Max. V	Max. V	Min. V	mA	mA	Max. mA ³	Max. mA ³	μA ⁴	μA ⁴
2 mA	-0.3	0.7	1.7	3.6	0.7	1.7	2	2	16	18	10	10
4 mA	-0.3	0.7	1.7	3.6	0.7	1.7	4	4	16	18	10	10
6 mA	-0.3	0.7	1.7	3.6	0.7	1.7	6	6	32	37	10	10
8 mA	-0.3	0.7	1.7	3.6	0.7	1.7	8	8	32	37	10	10

Notes:

1. IIL is the input leakage current per I/O pin over recommended operation conditions where $-0.3\text{ V} < V_{IN} < V_{IL}$.
2. IIH is the input leakage current per I/O pin over recommended operating conditions $V_{IH} < V_{IN} < V_{CCI}$. Input current is larger when operating outside recommended ranges.
3. Currents are measured at high temperature (100°C junction temperature) and maximum voltage.
4. Currents are measured at 85°C junction temperature.
5. Software default selection highlighted in gray.

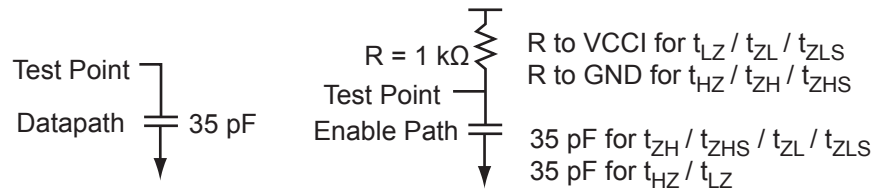

Figure 2-8 • AC Loading

Table 2-59 • AC Waveforms, Measuring Points, and Capacitive Loads

Input Low (V)	Input High (V)	Measuring Point* (V)	C _{LOAD} (pF)
0	2.5	1.2	35

Note: *Measuring point = V_{trip} . See Table 2-22 on page 2-22 for a complete table of trip points.

Table 2-71 • 1.8 V LVCMOS Low Slew
Commercial-Case Conditions: $T_J = 70^\circ\text{C}$, Worst-Case VCC = 1.425 V, Worst-Case VCCI = 1.7 V
Applicable to Advanced I/O Banks

Drive Strength	Speed Grade	t_{DOUT}	t_{DP}	t_{DIN}	t_{PY}	t_{EOUT}	t_{ZL}	t_{ZH}	t_{LZ}	t_{HZ}	t_{ZLS}	t_{ZHS}	Units
2 mA	Std.	0.66	15.53	0.04	1.22	0.43	14.11	15.53	2.78	1.60	16.35	17.77	ns
	-1	0.56	13.21	0.04	1.04	0.36	12.01	13.21	2.36	1.36	13.91	15.11	ns
	-2	0.49	11.60	0.03	0.91	0.32	10.54	11.60	2.07	1.19	12.21	13.27	ns
4 mA	Std.	0.66	10.48	0.04	1.22	0.43	10.41	10.48	3.23	2.73	12.65	12.71	ns
	-1	0.56	8.91	0.04	1.04	0.36	8.86	8.91	2.75	2.33	10.76	10.81	ns
	-2	0.49	7.82	0.03	0.91	0.32	7.77	7.82	2.41	2.04	9.44	9.49	ns
6 mA	Std.	0.66	8.05	0.04	1.22	0.43	8.20	7.84	3.54	3.27	10.43	10.08	ns
	-1	0.56	6.85	0.04	1.04	0.36	6.97	6.67	3.01	2.78	8.88	8.57	ns
	-2	0.49	6.01	0.03	0.91	0.32	6.12	5.86	2.64	2.44	7.79	7.53	ns
8 mA	Std.	0.66	7.50	0.04	1.22	0.43	7.64	7.30	3.61	3.41	9.88	9.53	ns
	-1	0.56	6.38	0.04	1.04	0.36	6.50	6.21	3.07	2.90	8.40	8.11	ns
	-2	0.49	5.60	0.03	0.91	0.32	5.71	5.45	2.69	2.55	7.38	7.12	ns
12 mA	Std.	0.66	7.29	0.04	1.22	0.43	7.23	7.29	3.71	3.95	9.47	9.53	ns
	-1	0.56	6.20	0.04	1.04	0.36	6.15	6.20	3.15	3.36	8.06	8.11	ns
	-2	0.49	5.45	0.03	0.91	0.32	5.40	5.45	2.77	2.95	7.07	7.12	ns
16 mA	Std.	0.66	7.29	0.04	1.22	0.43	7.23	7.29	3.71	3.95	9.47	9.53	ns
	-1	0.56	6.20	0.04	1.04	0.36	6.15	6.20	3.15	3.36	8.06	8.11	ns
	-2	0.49	5.45	0.03	0.91	0.32	5.40	5.45	2.77	2.95	7.07	7.12	ns

Note: For specific junction temperature and voltage supply levels, refer to Table 2-6 on page 2-6 for derating values.

Table 2-77 • Minimum and Maximum DC Input and Output Levels
Applicable to Standard Plus I/O Banks

1.5 V LVCMOS	VIL		VIH		VOL	VOH	IOL	IOH	IOSL	IOSH	IIL ¹	IIH ²
	Min. V	Max. V	Min. V	Max. V	Max. V	Min. V	mA	mA	Max. mA ³	Max. mA ³	μA ⁴	μA ⁴
2 mA	-0.3	0.35 * VCCI	0.65 * VCCI	1.575	0.25 * VCCI	0.75 * VCCI	2	2	16	13	10	10
4 mA	-0.3	0.35 * VCCI	0.65 * VCCI	1.575	0.25 * VCCI	0.75 * VCCI	4	4	33	25	10	10

Notes:

1. IIL is the input leakage current per I/O pin over recommended operation conditions where $-0.3\text{ V} < V_{IN} < V_{IL}$.
2. IIH is the input leakage current per I/O pin over recommended operating conditions $V_{IH} < V_{IN} < V_{CCI}$. Input current is larger when operating outside recommended ranges
3. Currents are measured at high temperature (100°C junction temperature) and maximum voltage.
4. Currents are measured at 85°C junction temperature.
5. Software default selection highlighted in gray.

Table 2-78 • Minimum and Maximum DC Input and Output Levels
Applicable to Standard I/O Banks

1.5 V LVCMOS	VIL		VIH		VOL	VOH	IOL	IOH	IOSL	IOSH	IIL ¹	IIH ²
	Min. V	Max. V	Min. V	Max. V	Max. V	Min. V	mA	mA	Max. mA ³	Max. mA ³	μA ⁴	μA ⁴
2 mA	-0.3	0.35 * VCCI	0.65 * VCCI	3.6	0.25 * VCCI	0.75 * VCCI	2	2	13	16	10	10

Notes:

1. IIL is the input leakage current per I/O pin over recommended operation conditions where $-0.3\text{ V} < V_{IN} < V_{IL}$.
2. IIH is the input leakage current per I/O pin over recommended operating conditions $V_{IH} < V_{IN} < V_{CCI}$. Input current is larger when operating outside recommended ranges.
3. Currents are measured at high temperature (100°C junction temperature) and maximum voltage.
4. Currents are measured at 85°C junction temperature.
5. Software default selection highlighted in gray.

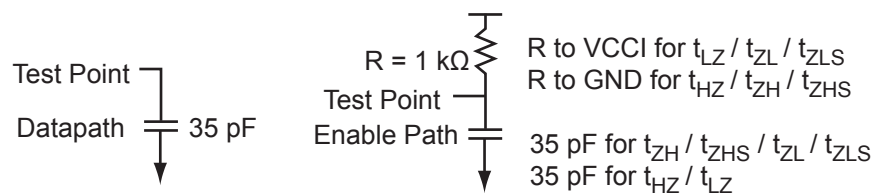

Figure 2-10 • AC Loading

Table 2-79 • AC Waveforms, Measuring Points, and Capacitive Loads

Input Low (V)	Input High (V)	Measuring Point* (V)	C _{LOAD} (pF)
0	1.5	0.75	35

Note: *Measuring point = V_{trip} . See Table 2-22 on page 2-22 for a complete table of trip points.

Table 2-93 • Minimum and Maximum DC Input and Output Levels

DC Parameter	Description	Min.	Max.	Min.	Max.	Min.	Max.	Units
VCCI	Supply Voltage	3.0		3.3		3.6		V
VOL	Output Low Voltage	0.96	1.27	1.06	1.43	1.30	1.57	V
VOH	Output High Voltage	1.8	2.11	1.92	2.28	2.13	2.41	V
VIL, VIH	Input Low, Input High Voltages	0	3.6	0	3.6	0	3.6	V
VODIFF	Differential Output Voltage	0.625	0.97	0.625	0.97	0.625	0.97	V
VOCM	Output Common-Mode Voltage	1.762	1.98	1.762	1.98	1.762	1.98	V
VICM	Input Common-Mode Voltage	1.01	2.57	1.01	2.57	1.01	2.57	V
VIDIFF	Input Differential Voltage	300		300		300		mV

Table 2-94 • AC Waveforms, Measuring Points, and Capacitive Loads

Input Low (V)	Input High (V)	Measuring Point* (V)
1.64	1.94	Cross point

Note: *Measuring point = V_{trip} . See [Table 2-22 on page 2-22](#) for a complete table of trip points.

Timing Characteristics

Table 2-95 • LVPECL

Commercial-Case Conditions: $T_J = 70^\circ\text{C}$, Worst-Case VCC = 1.425 V, Worst-Case VCCI = 3.0 V

Speed Grade	t_{DOUT}	t_{DP}	t_{DIN}	t_{PY}	Units
Std.	0.66	1.80	0.04	1.40	ns
-1	0.56	1.53	0.04	1.19	ns
-2	0.49	1.34	0.03	1.05	ns

Note: For specific junction temperature and voltage supply levels, refer to [Table 2-6 on page 2-6](#) for derating values.

I/O Register Specifications

Fully Registered I/O Buffers with Synchronous Enable and Asynchronous Preset

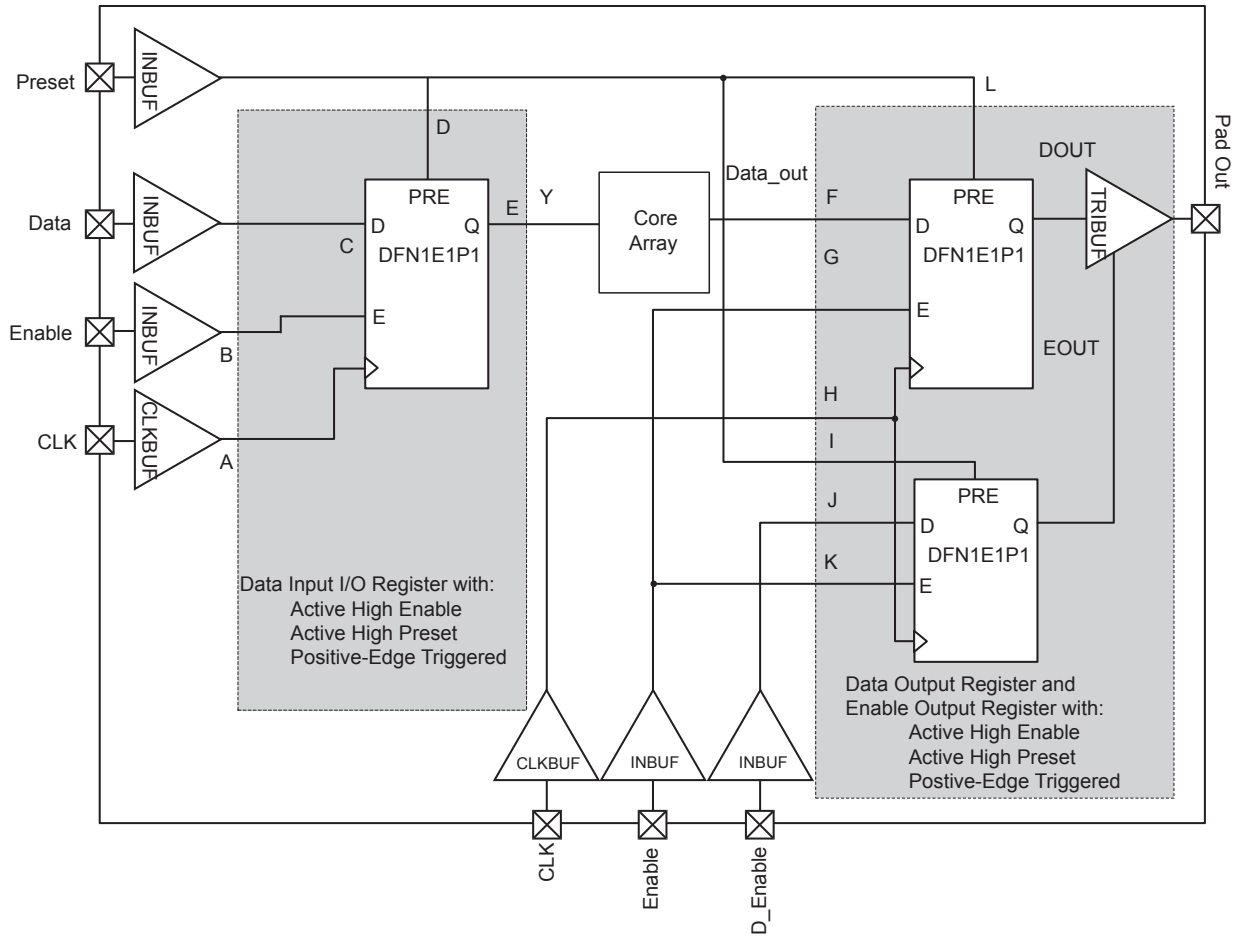

Figure 2-15 • Timing Model of Registered I/O Buffers with Synchronous Enable and Asynchronous Preset

Timing Characteristics

Table 2-105 • Combinatorial Cell Propagation Delays
 Commercial-Case Conditions: $T_j = 70^\circ\text{C}$, Worst-Case $V_{CC} = 1.425\text{ V}$

Combinatorial Cell	Equation	Parameter	-2	-1	Std.	Units
INV	$Y = !A$	t_{PD}	0.40	0.46	0.54	ns
AND2	$Y = A \cdot B$	t_{PD}	0.47	0.54	0.63	ns
NAND2	$Y = !(A \cdot B)$	t_{PD}	0.47	0.54	0.63	ns
OR2	$Y = A + B$	t_{PD}	0.49	0.55	0.65	ns
NOR2	$Y = !(A + B)$	t_{PD}	0.49	0.55	0.65	ns
XOR2	$Y = A \oplus B$	t_{PD}	0.74	0.84	0.99	ns
MAJ3	$Y = \text{MAJ}(A, B, C)$	t_{PD}	0.70	0.79	0.93	ns
XOR3	$Y = A \oplus B \oplus C$	t_{PD}	0.87	1.00	1.17	ns
MUX2	$Y = A !S + B S$	t_{PD}	0.51	0.58	0.68	ns
AND3	$Y = A \cdot B \cdot C$	t_{PD}	0.56	0.64	0.75	ns

Note: For specific junction temperature and voltage supply levels, refer to Table 2-6 on page 2-6 for derating values.

VersaTile Specifications as a Sequential Module

The ProASIC3 library offers a wide variety of sequential cells, including flip-flops and latches. Each has a data input and optional enable, clear, or preset. In this section, timing characteristics are presented for a representative sample from the library. For more details, refer to the *Fusion, IGLOO/e, and ProASIC3/E Macro Library Guide*.

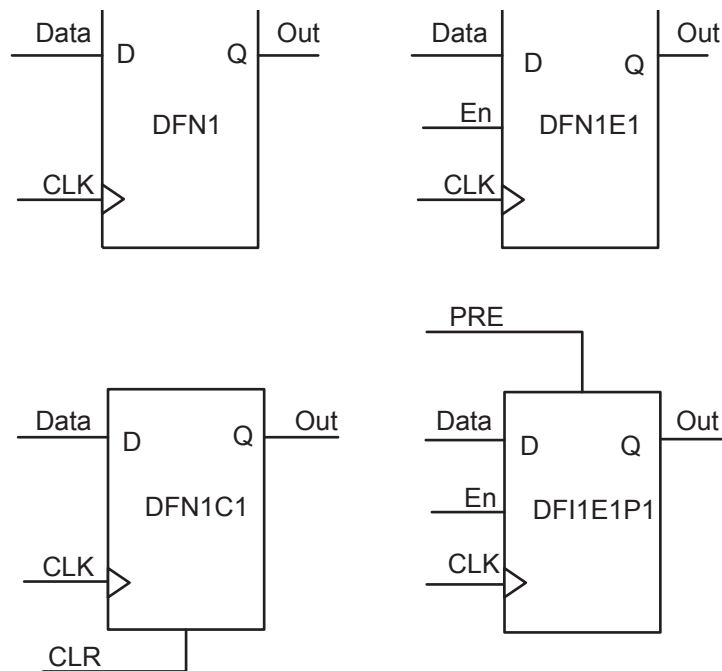

Figure 2-26 • Sample of Sequential Cells

Table 2-122 • A3P250 FIFO 2k×2
Worst Commercial-Case Conditions: T_J = 70°C, VCC = 1.425 V

Parameter	Description	-2	-1	Std.	Units
t _{ENS}	REN, WEN Setup Time	4.39	5.00	5.88	ns
t _{ENH}	REN, WEN Hold Time	0.00	0.00	0.00	ns
t _{BKS}	BLK Setup Time	0.19	0.22	0.26	ns
t _{BKH}	BLK Hold Time	0.00	0.00	0.00	ns
t _{DS}	Input Data (WD) Setup Time	0.18	0.21	0.25	ns
t _{DH}	Input Data (WD) Hold Time	0.00	0.00	0.00	ns
t _{CKQ1}	Clock High to New Data Valid on RD (flow-through)	2.36	2.68	3.15	ns
t _{CKQ2}	Clock High to New Data Valid on RD (pipelined)	0.89	1.02	1.20	ns
t _{RCKEF}	RCLK High to Empty Flag Valid	1.72	1.96	2.30	ns
t _{WCKFF}	WCLK High to Full Flag Valid	1.63	1.86	2.18	ns
t _{CKAF}	Clock High to Almost Empty/Full Flag Valid	6.19	7.05	8.29	ns
t _{RSTFG}	RESET Low to Empty/Full Flag Valid	1.69	1.93	2.27	ns
t _{RSTAF}	RESET Low to Almost Empty/Full Flag Valid	6.13	6.98	8.20	ns
t _{RSTBQ}	RESET Low to Data Out Low on RD (flow-through)	0.92	1.05	1.23	ns
	RESET Low to Data Out Low on RD (pipelined)	0.92	1.05	1.23	ns
t _{REMRSTB}	RESET Removal	0.29	0.33	0.38	ns
t _{RECRSTB}	RESET Recovery	1.50	1.71	2.01	ns
t _{MPWRSTB}	RESET Minimum Pulse Width	0.21	0.24	0.29	ns
t _{CYC}	Clock Cycle Time	3.23	3.68	4.32	ns
F _{MAX}	Maximum Frequency for FIFO	310	272	231	MHz

Table 2-123 • A3P250 FIFO 4k×1
Worst Commercial-Case Conditions: T_J = 70°C, VCC = 1.425 V

Parameter	Description	-2	-1	Std.	Units
t _{ENS}	REN, WEN Setup Time	4.86	5.53	6.50	ns
t _{ENH}	REN, WEN Hold Time	0.00	0.00	0.00	ns
t _{BKS}	BLK Setup Time	0.19	0.22	0.26	ns
t _{BKH}	BLK Hold Time	0.00	0.00	0.00	ns
t _{DS}	Input Data (WD) Setup Time	0.18	0.21	0.25	ns
t _{DH}	Input Data (WD) Hold Time	0.00	0.00	0.00	ns
t _{CKQ1}	Clock High to New Data Valid on RD (flow-through)	2.36	2.68	3.15	ns
t _{CKQ2}	Clock High to New Data Valid on RD (pipelined)	0.89	1.02	1.20	ns
t _{RCKEF}	RCLK High to Empty Flag Valid	1.72	1.96	2.30	ns
t _{WCKFF}	WCLK High to Full Flag Valid	1.63	1.86	2.18	ns
t _{CKAF}	Clock High to Almost Empty/Full Flag Valid	6.19	7.05	8.29	ns
t _{RSTFG}	RESET Low to Empty/Full Flag Valid	1.69	1.93	2.27	ns

JTAG 1532 Characteristics

JTAG timing delays do not include JTAG I/Os. To obtain complete JTAG timing, add I/O buffer delays to the corresponding standard selected; refer to the I/O timing characteristics in the "User I/O Characteristics" section on page 2-15 for more details.

Timing Characteristics

Table 2-125 • JTAG 1532

Commercial-Case Conditions: $T_J = 70^\circ\text{C}$, Worst-Case $V_{CC} = 1.425\text{ V}$

Parameter	Description	-2	-1	Std.	Units
t_{DISU}	Test Data Input Setup Time	0.50	0.57	0.67	ns
t_{DIHD}	Test Data Input Hold Time	1.00	1.13	1.33	ns
t_{TMSSU}	Test Mode Select Setup Time	0.50	0.57	0.67	ns
t_{TMDHD}	Test Mode Select Hold Time	1.00	1.13	1.33	ns
t_{TCK2Q}	Clock to Q (data out)	6.00	6.80	8.00	ns
t_{RSTB2Q}	Reset to Q (data out)	20.00	22.67	26.67	ns
F_{TCKMAX}	TCK Maximum Frequency	25.00	22.00	19.00	MHz
$t_{TRSTREM}$	ResetB Removal Time	0.00	0.00	0.00	ns
$t_{TRSTREC}$	ResetB Recovery Time	0.20	0.23	0.27	ns
$t_{TRSTMPW}$	ResetB Minimum Pulse	TBD	TBD	TBD	ns

Note: For specific junction temperature and voltage supply levels, refer to Table 2-6 on page 2-6 for derating values.

PQ208	
Pin Number	A3P250 Function
109	TRST
110	VJTAG
111	GDA0/IO60VDB1
112	GDA1/IO60UDB1
113	GDB0/IO59VDB1
114	GDB1/IO59UDB1
115	GDC0/IO58VDB1
116	GDC1/IO58UDB1
117	IO57VDB1
118	IO57UDB1
119	IO56NDB1
120	IO56PDB1
121	IO55RSB1
122	GND
123	VCCIB1
124	NC
125	NC
126	VCC
127	IO53NDB1
128	GCC2/IO53PDB1
129	GCB2/IO52PSB1
130	GND
131	GCA2/IO51PSB1
132	GCA1/IO50PDB1
133	GCA0/IO50NDB1
134	GCB0/IO49NDB1
135	GCB1/IO49PDB1
136	GCC0/IO48NDB1
137	GCC1/IO48PDB1
138	IO47NDB1
139	IO47PDB1
140	VCCIB1
141	GND
142	VCC
143	IO46RSB1
144	IO45NDB1

PQ208	
Pin Number	A3P250 Function
145	IO45PDB1
146	IO44NDB1
147	IO44PDB1
148	IO43NDB1
149	GBC2/IO43PDB1
150	IO42NDB1
151	GBB2/IO42PDB1
152	IO41NDB1
153	GBA2/IO41PDB1
154	VMV1
155	GNDQ
156	GND
157	NC
158	GBA1/IO40RSB0
159	GBA0/IO39RSB0
160	GBB1/IO38RSB0
161	GBB0/IO37RSB0
162	GND
163	GBC1/IO36RSB0
164	GBC0/IO35RSB0
165	IO34RSB0
166	IO33RSB0
167	IO32RSB0
168	IO31RSB0
169	IO30RSB0
170	VCCIB0
171	VCC
172	IO29RSB0
173	IO28RSB0
174	IO27RSB0
175	IO26RSB0
176	IO25RSB0
177	IO24RSB0
178	GND
179	IO23RSB0
180	IO22RSB0

PQ208	
Pin Number	A3P250 Function
181	IO21RSB0
182	IO20RSB0
183	IO19RSB0
184	IO18RSB0
185	IO17RSB0
186	VCCIB0
187	VCC
188	IO16RSB0
189	IO15RSB0
190	IO14RSB0
191	IO13RSB0
192	IO12RSB0
193	IO11RSB0
194	IO10RSB0
195	GND
196	IO09RSB0
197	IO08RSB0
198	IO07RSB0
199	IO06RSB0
200	VCCIB0
201	GAC1/IO05RSB0
202	GAC0/IO04RSB0
203	GAB1/IO03RSB0
204	GAB0/IO02RSB0
205	GAA1/IO01RSB0
206	GAA0/IO00RSB0
207	GNDQ
208	VMV0

FG144	
Pin Number	A3P250 Function
K1	GEBO/IO99NDB3
K2	GEA1/IO98PDB3
K3	GEA0/IO98NDB3
K4	GEA2/IO97RSB2
K5	IO90RSB2
K6	IO84RSB2
K7	GND
K8	IO66RSB2
K9	GDC2/IO63RSB2
K10	GND
K11	GDA0/IO60VDB1
K12	GDB0/IO59VDB1
L1	GND
L2	VMV3
L3	GEB2/IO96RSB2
L4	IO91RSB2
L5	VCCIB2
L6	IO82RSB2
L7	IO80RSB2
L8	IO72RSB2
L9	TMS
L10	VJTAG
L11	VMV2
L12	TRST
M1	GNDQ
M2	GEC2/IO95RSB2
M3	IO92RSB2
M4	IO89RSB2
M5	IO87RSB2
M6	IO85RSB2
M7	IO78RSB2
M8	IO76RSB2
M9	TDI
M10	VCCIB2
M11	VPUMP
M12	GNDQ

FG144	
Pin Number	A3P400 Function
K1	GEB0/IO136NDB3
K2	GEA1/IO135PDB3
K3	GEA0/IO135NDB3
K4	GEA2/IO134RSB2
K5	IO127RSB2
K6	IO121RSB2
K7	GND
K8	IO104RSB2
K9	GDC2/IO82RSB2
K10	GND
K11	GDA0/IO79VDB1
K12	GDB0/IO78VDB1
L1	GND
L2	VMV3
L3	GEB2/IO133RSB2
L4	IO128RSB2
L5	VCCIB2
L6	IO119RSB2
L7	IO114RSB2
L8	IO110RSB2
L9	TMS
L10	VJTAG
L11	VMV2
L12	TRST
M1	GNDQ
M2	GEC2/IO132RSB2
M3	IO129RSB2
M4	IO126RSB2
M5	IO124RSB2
M6	IO122RSB2
M7	IO117RSB2
M8	IO115RSB2
M9	TDI
M10	VCCIB2
M11	VPUMP
M12	GNDQ

FG256	
Pin Number	A3P400 Function
A1	GND
A2	GAA0/IO00RSB0
A3	GAA1/IO01RSB0
A4	GAB0/IO02RSB0
A5	IO16RSB0
A6	IO17RSB0
A7	IO22RSB0
A8	IO28RSB0
A9	IO34RSB0
A10	IO37RSB0
A11	IO41RSB0
A12	IO43RSB0
A13	GBB1/IO57RSB0
A14	GBA0/IO58RSB0
A15	GBA1/IO59RSB0
A16	GND
B1	GAB2/IO154UDB3
B2	GAA2/IO155UDB3
B3	IO12RSB0
B4	GAB1/IO03RSB0
B5	IO13RSB0
B6	IO14RSB0
B7	IO21RSB0
B8	IO27RSB0
B9	IO32RSB0
B10	IO38RSB0
B11	IO42RSB0
B12	GBC1/IO55RSB0
B13	GBB0/IO56RSB0
B14	IO44RSB0
B15	GBA2/IO60PDB1
B16	IO60NDB1
C1	IO154VDB3
C2	IO155VDB3
C3	IO11RSB0
C4	IO07RSB0

FG256	
Pin Number	A3P400 Function
C5	GAC0/IO04RSB0
C6	GAC1/IO05RSB0
C7	IO20RSB0
C8	IO24RSB0
C9	IO33RSB0
C10	IO39RSB0
C11	IO45RSB0
C12	GBC0/IO54RSB0
C13	IO48RSB0
C14	VMV0
C15	IO61NPB1
C16	IO63PDB1
D1	IO151VDB3
D2	IO151UDB3
D3	GAC2/IO153UDB3
D4	IO06RSB0
D5	GNDQ
D6	IO10RSB0
D7	IO19RSB0
D8	IO26RSB0
D9	IO30RSB0
D10	IO40RSB0
D11	IO46RSB0
D12	GNDQ
D13	IO47RSB0
D14	GBB2/IO61PPB1
D15	IO53RSB0
D16	IO63NDB1
E1	IO150PDB3
E2	IO08RSB0
E3	IO153VDB3
E4	IO152VDB3
E5	VMV0
E6	VCCIB0
E7	VCCIB0
E8	IO25RSB0

FG256	
Pin Number	A3P400 Function
E9	IO31RSB0
E10	VCCIB0
E11	VCCIB0
E12	VMV1
E13	GBC2/IO62PDB1
E14	IO65RSB1
E15	IO52RSB0
E16	IO66PDB1
F1	IO150NDB3
F2	IO149NPB3
F3	IO09RSB0
F4	IO152UDB3
F5	VCCIB3
F6	GND
F7	VCC
F8	VCC
F9	VCC
F10	VCC
F11	GND
F12	VCCIB1
F13	IO62NDB1
F14	IO49RSB0
F15	IO64PPB1
F16	IO66NDB1
G1	IO148NDB3
G2	IO148PDB3
G3	IO149PPB3
G4	GFC1/IO147PPB3
G5	VCCIB3
G6	VCC
G7	GND
G8	GND
G9	GND
G10	GND
G11	VCC
G12	VCCIB1

FG256	
Pin Number	A3P400 Function
G13	GCC1/IO67PPB1
G14	IO64NPB1
G15	IO73PDB1
G16	IO73NDB1
H1	GFB0/IO146NPB3
H2	GFA0/IO145NDB3
H3	GFB1/IO146PPB3
H4	VCOMPLF
H5	GFC0/IO147NPB3
H6	VCC
H7	GND
H8	GND
H9	GND
H10	GND
H11	VCC
H12	GCC0/IO67NPB1
H13	GCB1/IO68PPB1
H14	GCA0/IO69NPB1
H15	NC
H16	GCB0/IO68NPB1
J1	GFA2/IO144PPB3
J2	GFA1/IO145PDB3
J3	VCCPLF
J4	IO143NDB3
J5	GFB2/IO143PDB3
J6	VCC
J7	GND
J8	GND
J9	GND
J10	GND
J11	VCC
J12	GCB2/IO71PPB1
J13	GCA1/IO69PPB1
J14	GCC2/IO72PPB1
J15	NC
J16	GCA2/IO70PDB1

FG256	
Pin Number	A3P400 Function
K1	GFC2/IO142PDB3
K2	IO144NPB3
K3	IO141PPB3
K4	IO120RSB2
K5	VCCIB3
K6	VCC
K7	GND
K8	GND
K9	GND
K10	GND
K11	VCC
K12	VCCIB1
K13	IO71NPB1
K14	IO74RSB1
K15	IO72NPB1
K16	IO70NDB1
L1	IO142NDB3
L2	IO141NPB3
L3	IO125RSB2
L4	IO139RSB3
L5	VCCIB3
L6	GND
L7	VCC
L8	VCC
L9	VCC
L10	VCC
L11	GND
L12	VCCIB1
L13	GDB0/IO78VPB1
L14	IO76VDB1
L15	IO76UDB1
L16	IO75PDB1
M1	IO140PDB3
M2	IO130RSB2
M3	IO138NPB3
M4	GEC0/IO137NPB3

FG256	
Pin Number	A3P400 Function
M5	VMV3
M6	VCCIB2
M7	VCCIB2
M8	IO108RSB2
M9	IO101RSB2
M10	VCCIB2
M11	VCCIB2
M12	VMV2
M13	IO83RSB2
M14	GDB1/IO78UPB1
M15	GDC1/IO77UDB1
M16	IO75NDB1
N1	IO140NDB3
N2	IO138PPB3
N3	GEC1/IO137PPB3
N4	IO131RSB2
N5	GNDQ
N6	GEA2/IO134RSB2
N7	IO117RSB2
N8	IO111RSB2
N9	IO99RSB2
N10	IO94RSB2
N11	IO87RSB2
N12	GNDQ
N13	IO93RSB2
N14	VJTAG
N15	GDC0/IO77VDB1
N16	GDA1/IO79UDB1
P1	GEB1/IO136PDB3
P2	GEB0/IO136NDB3
P3	VMV2
P4	IO129RSB2
P5	IO128RSB2
P6	IO122RSB2
P7	IO115RSB2
P8	IO110RSB2

FG484	
Pin Number	A3P600 Function
K19	IO75NDB1
K20	NC
K21	IO76NDB1
K22	IO76PDB1
L1	NC
L2	IO155PDB3
L3	NC
L4	GFB0/IO163NPB3
L5	GFA0/IO162NDB3
L6	GFB1/IO163PPB3
L7	VCOMPLF
L8	GFC0/IO164NPB3
L9	VCC
L10	GND
L11	GND
L12	GND
L13	GND
L14	VCC
L15	GCC0/IO69NPB1
L16	GCB1/IO70PPB1
L17	GCA0/IO71NPB1
L18	IO67NPB1
L19	GCB0/IO70NPB1
L20	IO77PDB1
L21	IO77NDB1
L22	IO78NPB1
M1	NC
M2	IO155NDB3
M3	IO158NPB3
M4	GFA2/IO161PPB3
M5	GFA1/IO162PDB3
M6	VCCPLF
M7	IO160NDB3
M8	GFB2/IO160PDB3
M9	VCC
M10	GND

FG484	
Pin Number	A3P600 Function
M11	GND
M12	GND
M13	GND
M14	VCC
M15	GCB2/IO73PPB1
M16	GCA1/IO71PPB1
M17	GCC2/IO74PPB1
M18	IO80PPB1
M19	GCA2/IO72PDB1
M20	IO79PPB1
M21	IO78PPB1
M22	NC
N1	IO154NDB3
N2	IO154PDB3
N3	NC
N4	GFC2/IO159PDB3
N5	IO161NPB3
N6	IO156PPB3
N7	IO129RSB2
N8	VCCIB3
N9	VCC
N10	GND
N11	GND
N12	GND
N13	GND
N14	VCC
N15	VCCIB1
N16	IO73NPB1
N17	IO80NPB1
N18	IO74NPB1
N19	IO72NDB1
N20	NC
N21	IO79NPB1
N22	NC
P1	NC
P2	IO153PDB3

FG484	
Pin Number	A3P600 Function
P3	IO153NDB3
P4	IO159NDB3
P5	IO156NPB3
P6	IO151PPB3
P7	IO158PPB3
P8	VCCIB3
P9	GND
P10	VCC
P11	VCC
P12	VCC
P13	VCC
P14	GND
P15	VCCIB1
P16	GDB0/IO87NPB1
P17	IO85NDB1
P18	IO85PDB1
P19	IO84PDB1
P20	NC
P21	IO81PDB1
P22	NC
R1	NC
R2	NC
R3	VCC
R4	IO150PDB3
R5	IO151NPB3
R6	IO147NPB3
R7	GEC0/IO146NPB3
R8	VMV3
R9	VCCIB2
R10	VCCIB2
R11	IO117RSB2
R12	IO110RSB2
R13	VCCIB2
R14	VCCIB2
R15	VMV2
R16	IO94RSB2

Revision	Changes	Page
Advance v0.6 (continued)	The "RESET" section was updated.	2-25
	The "WCLK and RCLK" section was updated.	2-25
	The "RESET" section was updated.	2-25
	The "RESET" section was updated.	2-27
	The "Introduction" of the "Advanced I/Os" section was updated.	2-28
	The "I/O Banks" section is new. This section explains the following types of I/Os: Advanced Standard+ Standard Table 2-12 • Automotive ProASIC3 Bank Types Definition and Differences is new. This table describes the standards listed above.	2-29
	PCI-X 3.3 V was added to the Compatible Standards for 3.3 V in Table 2-11 • VCCI Voltages and Compatible Standards	2-29
	Table 2-13 • ProASIC3 I/O Features was updated.	2-30
	The "Double Data Rate (DDR) Support" section was updated to include information concerning implementation of the feature.	2-32
	The "Electrostatic Discharge (ESD) Protection" section was updated to include testing information.	2-35
	Level 3 and 4 descriptions were updated in Table 2-43 • I/O Hot-Swap and 5 V Input Tolerance Capabilities in ProASIC3 Devices.	2-64
	The notes in Table 2-43 • I/O Hot-Swap and 5 V Input Tolerance Capabilities in ProASIC3 Devices were updated.	2-64
	The "Simultaneous Switching Outputs (SSOs) and Printed Circuit Board Layout" section is new.	2-41
	A footnote was added to Table 2-14 • Maximum I/O Frequency for Single-Ended and Differential I/Os in All Banks in Automotive ProASIC3 Devices (maximum drive strength and high slew selected).	2-30
	Table 2-18 • Automotive ProASIC3 I/O Attributes vs. I/O Standard Applications	2-45
	Table 2-50 • ProASIC3 Output Drive (OUT_DRIVE) for Standard I/O Bank Type (A3P030 device)	2-83
	Table 2-51 • ProASIC3 Output Drive for Standard+ I/O Bank Type was updated.	2-84
	Table 2-54 • ProASIC3 Output Drive for Advanced I/O Bank Type was updated.	2-84
	The "x" was updated in the "User I/O Naming Convention" section.	2-48
	The "VCC Core Supply Voltage" pin description was updated.	2-50
The "VMVx I/O Supply Voltage (quiet)" pin description was updated to include information concerning leaving the pin unconnected.	2-50	
The "VJTAG JTAG Supply Voltage" pin description was updated.	2-50	
The "VPUMP Programming Supply Voltage" pin description was updated to include information on what happens when the pin is tied to ground.	2-50	
The "I/O User Input/Output" pin description was updated to include information on what happens when the pin is unused.	2-50	
The "JTAG Pins" section was updated to include information on what happens when the pin is unused.	2-51	

Revision	Changes	Page
Advance v0.2, (continued)	Table 2-43 was updated.	2-64
	Table 2-18 was updated.	2-45
	Pin descriptions in the "JTAG Pins" section were updated.	2-51
	The "User I/O Naming Convention" section was updated.	2-48
	Table 3-7 was updated.	3-6
	The "Methodology" section was updated.	3-10
	Table 3-40 and Table 3-39 were updated.	3-33,3-32
	The A3P250 "100-Pin VQFP*" pin table was updated.	4-14
	The A3P250 "208-Pin PQFP*" pin table was updated.	4-23
	The A3P1000 "208-Pin PQFP*" pin table was updated.	4-29
	The A3P250 "144-Pin FBGA*" pin table was updated.	4-36
	The A3P1000 "144-Pin FBGA*" pin table was updated.	4-32
	The A3P250 "256-Pin FBGA*" pin table was updated.	4-45
	The A3P1000 "256-Pin FBGA*" pin table was updated.	4-54
The A3P1000 "484-Pin FBGA*" pin table was updated.	4-68	