

Welcome to [E-XFL.COM](https://www.e-xfl.com)

Embedded - System On Chip (SoC): The Heart of Modern Embedded Systems

Embedded - System On Chip (SoC) refers to an integrated circuit that consolidates all the essential components of a computer system into a single chip. This includes a microprocessor, memory, and other peripherals, all packed into one compact and efficient package. SoCs are designed to provide a complete computing solution, optimizing both space and power consumption, making them ideal for a wide range of embedded applications.

What are Embedded - System On Chip (SoC)?

System On Chip (SoC) integrates multiple functions of a computer or electronic system onto a single chip. Unlike traditional multi-chip solutions, SoCs combine a central

Details

Product Status	Active
Architecture	MCU, FPGA
Core Processor	ARM® Cortex®-M3
Flash Size	256KB
RAM Size	64KB
Peripherals	DDR, PCIe, SERDES
Connectivity	CANbus, Ethernet, I ² C, SPI, UART/USART, USB
Speed	166MHz
Primary Attributes	FPGA - 25K Logic Modules
Operating Temperature	-40°C ~ 100°C (Tj)
Package / Case	484-BGA
Supplier Device Package	484-FPBGA (23x23)
Purchase URL	https://www.e-xfl.com/product-detail/microchip-technology/m2s025t-1fg484i

Table 161	LVDS DC Input Voltage Specification	55
Table 162	LVDS25 Receiver Characteristics for MSIO I/O Bank (Input Buffers)	56
Table 163	LVDS DC Output Voltage Specification	56
Table 164	LVDS DC Differential Voltage Specification	56
Table 165	LVDS Minimum and Maximum AC Switching Speed	56
Table 166	LVDS AC Impedance Specifications	56
Table 167	LVDS AC Test Parameter Specifications	56
Table 168	LVDS33 Receiver Characteristics for MSIO I/O Bank (Input Buffers)	57
Table 169	LVDS33 Transmitter Characteristics for MSIO I/O Bank (Output and Tristate Buffers)	57
Table 170	LVDS25 Receiver Characteristics for MSIOD I/O Bank (Input Buffers)	57
Table 171	LVDS25 Transmitter Characteristics for MSIO I/O Bank (Output and Tristate Buffers)	57
Table 172	LVDS25 Transmitter Characteristics for MSIOD I/O Bank (Output and Tristate Buffers)	57
Table 173	B-LVDS Recommended DC Operating Conditions	58
Table 174	B-LVDS DC Input Voltage Specification	58
Table 175	B-LVDS DC Output Voltage Specification (for MSIO I/O Bank Only)	58
Table 176	B-LVDS DC Differential Voltage Specification	58
Table 177	B-LVDS Minimum and Maximum AC Switching Speed	58
Table 178	B-LVDS AC Impedance Specifications	58
Table 179	B-LVDS AC Test Parameter Specifications	58
Table 180	B-LVDS AC Switching Characteristics for Receiver for MSIO I/O Bank (Input Buffers)	59
Table 181	B-LVDS AC Switching Characteristics for Receiver for MSIOD I/O Bank (Input Buffers)	59
Table 182	B-LVDS AC Switching Characteristics for Transmitter (for MSIO I/O Bank - Output and Tristate Buffers)	59
Table 183	M-LVDS Recommended DC Operating Conditions	59
Table 184	M-LVDS DC Input Voltage Specification	59
Table 185	M-LVDS AC Switching Characteristics for Receiver (for MSIO I/O Bank - Input Buffers)	60
Table 186	M-LVDS DC Voltage Specification Output Voltage Specification (for MSIO I/O Bank Only)	60
Table 187	M-LVDS Differential Voltage Specification	60
Table 188	M-LVDS Minimum and Maximum AC Switching Speed for MSIO I/O Bank	60
Table 189	M-LVDS AC Impedance Specifications	60
Table 190	M-LVDS AC Test Parameter Specifications	60
Table 191	Mini-LVDS Recommended DC Operating Conditions	61
Table 192	Mini-LVDS DC Input Voltage Specification	61
Table 193	Mini-LVDS DC Output Voltage Specification	61
Table 194	Mini-LVDS DC Differential Voltage Specification	61
Table 195	Mini-LVDS Minimum and Maximum AC Switching Speed	61
Table 196	M-LVDS AC Switching Characteristics for Receiver (for MSIOD I/O Bank - Input Buffers)	61
Table 197	M-LVDS AC Switching Characteristics for Transmitter (for MSIO I/O Bank - Output and Tristate Buffers)	61
Table 198	Mini-LVDS AC Switching Characteristics for Receiver (for MSIO I/O Bank - Input Buffers)	62
Table 199	Mini-LVDS AC Switching Characteristics for Transmitter for MSIO I/O Bank (Output and Tristate Buffers)	62
Table 200	Mini-LVDS AC Switching Characteristics for Transmitter (for MSIOD I/O Bank - Output and Tristate Buffers)	62
Table 201	Mini-LVDS AC Impedance Specifications	62
Table 202	Mini-LVDS AC Test Parameter Specifications	62
Table 203	RSDS Recommended DC Operating Conditions	63
Table 204	RSDS DC Input Voltage Specification	63
Table 205	RSDS DC Output Voltage Specification	63
Table 206	RSDS Differential Voltage Specification	63
Table 207	RSDS Minimum and Maximum AC Switching Speed	63
Table 208	RSDS AC Impedance Specifications	63
Table 209	RSDS AC Test Parameter Specifications	63
Table 210	RSDS AC Switching Characteristics for Receiver (for MSIO I/O Bank - Input Buffers)	64
Table 211	RSDS AC Switching Characteristics for Receiver (for MSIOD I/O Bank - Input Buffers)	64
Table 212	RSDS AC Switching Characteristics for Transmitter (for MSIO I/O Bank - Output and Tristate Buffers)	64
Table 213	RSDS AC Switching Characteristics for Transmitter (for MSIOD I/O Bank - Output and Tristate Buffers)	64

Table 11 • SmartFusion2 and IGLOO2 Quiescent Supply Current ($V_{DD} = 1.2\text{ V}$) – Typical Process

Symbol	Modes	005	010	025	050	060	090	150	Unit	Conditions
IDC2	Flash*Freeze	1.4	2.6	3.7	5.1	5.0	5.1	8.9	mA	Typical ($T_J = 25\text{ }^\circ\text{C}$)
		12.0	20.0	26.6	35.3	35.4	35.7	57.8	mA	Commercial ($T_J = 85\text{ }^\circ\text{C}$)
		18.5	30.8	41.0	54.5	54.5	55.0	89.0	mA	Industrial ($T_J = 100\text{ }^\circ\text{C}$)

Table 12 • SmartFusion2 and IGLOO2 Quiescent Supply Current ($V_{DD} = 1.26\text{ V}$) – Worst-Case Process

Symbol	Modes	005	010	025	050	060	090	150	Unit	Conditions
IDC1	Non-Flash*Freeze	43.8	57.0	84.6	132.3	161.4	163.0	242.5	mA	Commercial ($T_J = 85\text{ }^\circ\text{C}$)
		65.3	85.7	127.8	200.9	245.4	247.8	369.0	mA	Industrial ($T_J = 100\text{ }^\circ\text{C}$)
IDC2	Flash*Freeze	29.1	45.6	51.7	62.7	69.3	70.0	84.8	mA	Commercial ($T_J = 85\text{ }^\circ\text{C}$)
		44.9	70.3	79.7	96.5	106.8	107.8	130.6	mA	Industrial ($T_J = 100\text{ }^\circ\text{C}$)

2.3.2.2 Programming Currents

The following tables represent programming, verify and Inrush currents for SmartFusion2 SoC and IGLOO2 FPGA devices.

Table 13 • Currents During Program Cycle, $0\text{ }^\circ\text{C} \leq T_J \leq 85\text{ }^\circ\text{C}$ – Typical Process

Power Supplies	Voltage (V)	005	010	025	050	060	090	150 ¹	Unit
V_{DD}	1.26	46	53	55	58	30	42	52	mA
V_{PP}	3.46	8	11	6	10	9	12	12	mA
V_{PPNVM}	3.46	1	2	2	3	3	3		mA
V_{DDI}	2.62	31	16	17	1	12	12	81	mA
	3.46	62	31	36	1	12	17	84	mA
Number of banks		7	8	8	10	10	9	19	

1. V_{PP} and V_{PPNVM} are internally shorted.

Table 14 • Currents During Verify Cycle, $0\text{ }^\circ\text{C} \leq T_J \leq 85\text{ }^\circ\text{C}$ – Typical Process

Power Supplies	Voltage (V)	005	010	025	050	060	090	150 ¹	Unit
V_{DD}	1.26	44	53	55	58	33	41	51	mA
V_{PP}	3.46	6	5	3	15	8	11	12	mA
V_{PPNVM}	3.46	1	0	0	1	1	1		mA
V_{DDI}	2.62	31	16	17	1	12	11	81	mA
	3.46	61	32	36	1	12	17	84	mA
Number of banks		7	8	8	10	10	9	19	

1. V_{PP} and V_{PPNVM} are internally shorted.

2.3.5.2 Output Buffer and AC Loading

The following figure shows the output buffer and AC loading.

Figure 4 • Output Buffer AC Loading

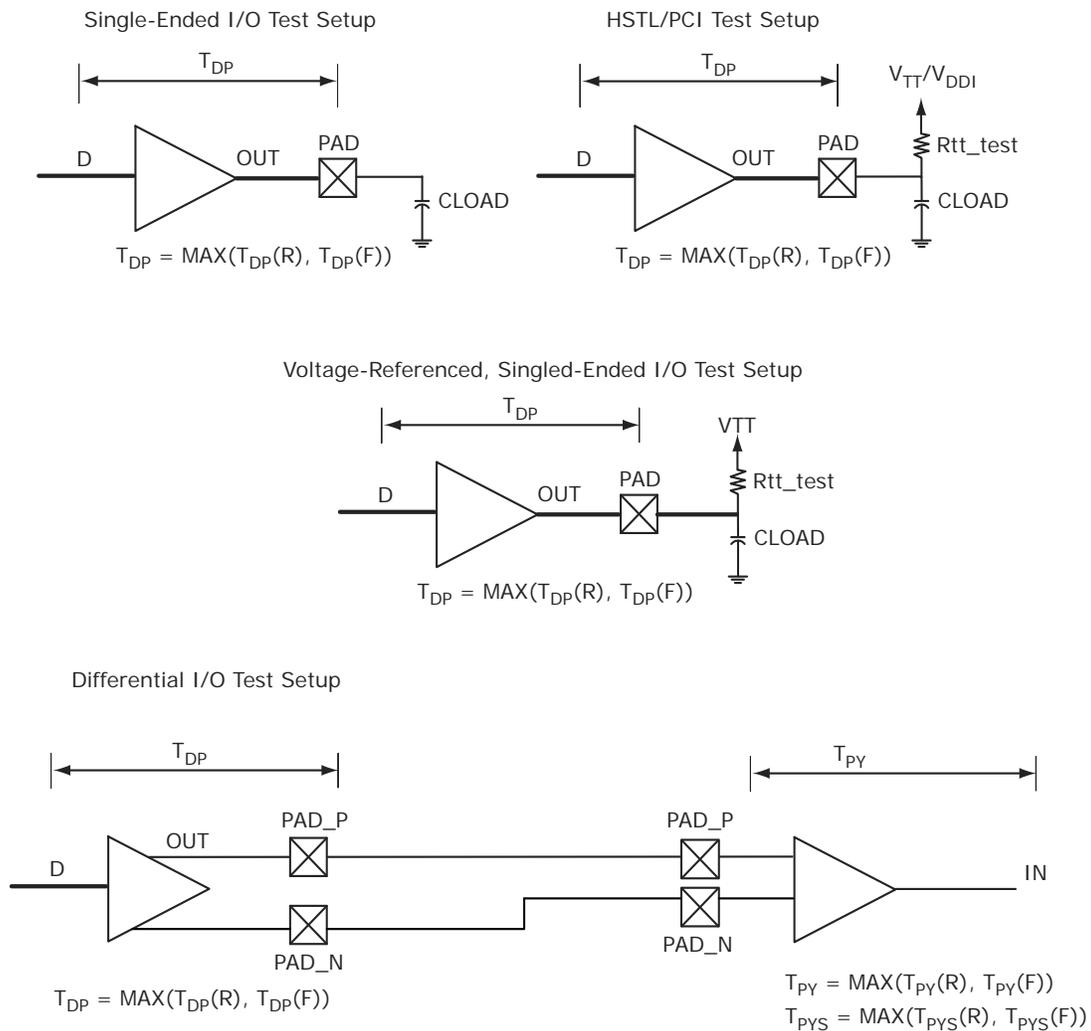

Table 57 • LVCMOS 1.8 V Transmitter Characteristics for DDRIO I/O Bank with Fixed Code (Output and Tristate Buffers)

Output Drive Selection	Slew Control	T _{DP}		T _{ZL}		T _{ZH}		T _{HZ} ¹		T _{LZ} ¹		Unit
		-1	-Std	-1	-Std	-1	-Std	-1	-Std	-1	-Std	
2 mA	Slow	4.234	4.981	3.646	4.29	4.245	4.995	4.908	5.774	4.434	5.216	ns
	Medium	3.824	4.498	3.282	3.861	3.834	4.511	4.625	5.441	4.116	4.843	ns
	Medium fast	3.627	4.267	3.111	3.66	3.637	4.279	4.481	5.272	3.984	4.687	ns
	Fast	3.605	4.241	3.097	3.644	3.615	4.253	4.472	5.262	3.973	4.674	ns
4 mA	Slow	3.923	4.615	3.314	3.9	3.918	4.61	5.403	6.356	4.894	5.757	ns
	Medium	3.518	4.138	2.961	3.484	3.515	4.135	5.121	6.025	4.561	5.366	ns
	Medium fast	3.321	3.907	2.783	3.275	3.317	3.903	4.966	5.843	4.426	5.206	ns
	Fast	3.301	3.883	2.77	3.259	3.296	3.878	4.957	5.831	4.417	5.196	ns
6 mA	Slow	3.71	4.364	3.104	3.652	3.702	4.355	5.62	6.612	5.08	5.977	ns
	Medium	3.333	3.921	2.779	3.27	3.325	3.913	5.346	6.289	4.777	5.62	ns
	Medium fast	3.155	3.712	2.62	3.083	3.146	3.702	5.21	6.13	4.657	5.479	ns
	Fast	3.134	3.688	2.608	3.068	3.125	3.677	5.202	6.12	4.648	5.468	ns
8 mA	Slow	3.619	4.258	3.007	3.538	3.607	4.244	5.815	6.841	5.249	6.175	ns
	Medium	3.246	3.819	2.686	3.16	3.236	3.807	5.542	6.52	4.936	5.807	ns
	Medium fast	3.066	3.607	2.525	2.971	3.054	3.593	5.405	6.359	4.811	5.66	ns
	Fast	3.046	3.584	2.513	2.957	3.034	3.57	5.401	6.353	4.803	5.651	ns
10 mA	Slow	3.498	4.115	2.878	3.386	3.481	4.096	6.046	7.113	5.444	6.404	ns
	Medium	3.138	3.692	2.569	3.023	3.126	3.678	5.782	6.803	5.129	6.034	ns
	Medium fast	2.966	3.489	2.414	2.841	2.951	3.472	5.666	6.665	5.013	5.897	ns
	Fast	2.945	3.464	2.401	2.826	2.93	3.448	5.659	6.658	5.003	5.886	ns
12 mA	Slow	3.417	4.02	2.807	3.303	3.401	4.002	6.083	7.156	5.464	6.428	ns
	Medium	3.076	3.618	2.519	2.964	3.063	3.604	5.828	6.856	5.176	6.089	ns
	Medium fast	2.913	3.427	2.376	2.795	2.898	3.41	5.725	6.736	5.072	5.966	ns
	Fast	2.894	3.405	2.362	2.78	2.879	3.388	5.715	6.724	5.064	5.957	ns
16 mA	Slow	3.366	3.96	2.751	3.237	3.348	3.939	6.226	7.324	5.576	6.56	ns
	Medium	3.03	3.565	2.47	2.906	3.017	3.55	5.981	7.036	5.282	6.214	ns
	Medium fast	2.87	3.377	2.328	2.739	2.854	3.358	5.895	6.935	5.18	6.094	ns
	Fast	2.853	3.357	2.314	2.723	2.837	3.338	5.889	6.929	5.177	6.09	ns

1. Delay increases with drive strength are inherent to built-in slew control circuitry for simultaneous switching output (SSO) management.

Table 70 • LVCMOS 1.5 V Transmitter Characteristics for DDRIO I/O Bank (Output and Tristate Buffers)
(continued)

Output Drive Selection	Slew Control	T _{DP}		T _{ZL}		T _{ZH}		T _{HZ} ¹		T _{LZ} ¹		Unit
		-1	-Std	-1	-Std	-1	-Std	-1	-Std	-1	-Std	
6 mA	Slow	4.244	4.993	3.465	4.076	4.233	4.979	6.39	7.518	5.736	6.748	ns
	Medium	3.774	4.44	3.05	3.587	3.762	4.426	6.114	7.193	5.397	6.35	ns
	Medium fast	3.544	4.17	2.839	3.339	3.529	4.152	5.978	7.033	5.27	6.2	ns
	Fast	3.519	4.14	2.82	3.317	3.504	4.122	5.965	7.017	5.259	6.187	ns
8 mA	Slow	4.099	4.823	3.311	3.894	4.087	4.807	6.584	7.746	5.854	6.888	ns
	Medium	3.656	4.301	2.927	3.443	3.642	4.284	6.311	7.425	5.553	6.533	ns
	Medium fast	3.437	4.044	2.731	3.213	3.42	4.023	6.182	7.273	5.435	6.394	ns
	Fast	3.41	4.012	2.715	3.193	3.393	3.991	6.178	7.269	5.425	6.383	ns
10 mA	Slow	4.029	4.74	3.238	3.809	4.015	4.723	6.732	7.921	5.965	7.018	ns
	Medium	3.601	4.237	2.867	3.372	3.586	4.218	6.473	7.615	5.669	6.669	ns
	Medium fast	3.384	3.981	2.672	3.143	3.365	3.958	6.351	7.471	5.55	6.529	ns
	Fast	3.357	3.949	2.655	3.123	3.338	3.927	6.345	7.464	5.54	6.518	ns
12 mA	Slow	3.974	4.675	3.196	3.759	3.958	4.656	6.842	8.049	6.068	7.139	ns
	Medium	3.55	4.176	2.827	3.326	3.534	4.157	6.584	7.746	5.751	6.766	ns
	Medium fast	3.345	3.935	2.638	3.103	3.325	3.911	6.488	7.633	5.641	6.637	ns
	Fast	3.316	3.902	2.621	3.083	3.297	3.878	6.486	7.63	5.626	6.619	ns

1. Delay increases with drive strength are inherent to built-in slew control circuitry for simultaneous switching output (SSO) management.

Table 71 • LVCMOS 1.5 V Transmitter Characteristics for MSIO I/O Bank (Output and Tristate Buffers)

Output Drive Selection	Slew Control	T _{DP}		T _{ZL}		T _{ZH}		T _{HZ} ¹		T _{LZ} ¹		Unit
		-1	-Std	-1	-Std	-1	-Std	-1	-Std	-1	-Std	
2 mA	Slow	4.423	5.203	5.397	6.35	5.686	6.69	5.609	6.599	5.561	6.542	ns
4 mA	Slow	4.05	4.765	4.503	5.298	4.92	5.788	7.358	8.657	6.525	7.677	ns
6 mA	Slow	4.081	4.801	4.259	5.012	4.699	5.528	7.659	9.011	6.709	7.893	ns
8 mA	Slow	4.234	4.98	4.068	4.786	4.521	5.319	8.218	9.668	7.05	8.294	ns

1. Delay increases with drive strength are inherent to built-in slew control circuitry for simultaneous switching output (SSO) management.

Table 95 • HSTL DC Output Voltage Specification Applicable to DDRIO I/O Bank Only

Parameter	Symbol	Min	Max	Unit
HSTL Class I				
DC output logic high	V_{OH}	$V_{DDI} - 0.4$		V
DC output logic low	V_{OL}		0.4	V
Output minimum source DC current (MSIO and DDRIO I/O banks)	I_{OH} at V_{OH}	-8.0		mA
Output minimum sink current (MSIO and DDRIO I/O banks)	I_{OL} at V_{OL}	8.0		mA
HSTL Class II				
DC output logic high	V_{OH}	$V_{DDI} - 0.4$		V
DC output logic low	V_{OL}		0.4	V
Output minimum source DC current	I_{OH} at V_{OH}	-16.0		mA
Output minimum sink current	I_{OL} at V_{OL}	16.0		mA

Table 96 • HSTL DC Differential Voltage Specification

Parameter	Symbol	Min	Unit
DC input differential voltage	V_{ID} (DC)	0.2	V

Table 97 • HSTL AC Differential Voltage Specifications

Parameter	Symbol	Min	Max	Unit
AC input differential voltage	V_{DIFF}	0.4		V
AC differential cross point voltage	V_x	0.68	0.9	V

Table 98 • HSTL Minimum and Maximum AC Switching Speed

Parameter	Symbol	Max	Unit	Conditions
Maximum data rate	D_{MAX}	400	Mbps	AC loading: per JEDEC specifications

Table 99 • HSTL Impedance Specification

Parameter	Symbol	Typ	Unit	Conditions
Supported output driver calibrated impedance (for DDRIO I/O bank)	R_{REF}	25.5, 47.8	Ω	Reference resistance = 191 Ω
Effective impedance value (ODT for DDRIO I/O bank only)	R_{TT}	47.8	Ω	Reference resistance = 191 Ω

Table 112 • SSTL2 Receiver Characteristics for MSIO I/O Bank (Input Buffers)

	On-Die Termination (ODT)	T _{PY}		Unit
		-1	-Std	
Pseudo differential	None	2.798	3.293	ns
True differential	None	2.733	3.215	ns

Table 113 • DDR1/SSTL2 Receiver Characteristics for MSIOD I/O Bank (Input Buffers)

	On-Die Termination (ODT)	T _{PY}		Unit
		-1	-Std	
Pseudo differential	None	2.476	2.913	ns
True differential	None	2.475	2.911	ns

Table 114 • SSTL2 Class I Transmitter Characteristics for DDRIO I/O Bank (Output and Tristate Buffers)

	T _{DP}		T _{ZL}		T _{ZH}		T _{HZ}		T _{LZ}		Unit
	-1	-Std	-1	-Std	-1	-Std	-1	-Std	-1	-Std	
Single-ended	2.26	2.66	1.99	2.341	1.985	2.335	2.135	2.512	2.13	2.505	ns
Differential	2.26	2.658	2.202	2.591	2.201	2.589	2.393	2.815	2.392	2.814	ns

Table 115 • DDR1/SSTL2 Class I Transmitter Characteristics for MSIO I/O Bank (Output and Tristate Buffers)

	T _{DP}		T _{ZL}		T _{ZH}		T _{HZ}		T _{LZ}		Unit
	-1	-Std	-1	-Std	-1	-Std	-1	-Std	-1	-Std	
Single-ended	2.055	2.417	2.037	2.396	2.03	2.388	2.068	2.433	2.061	2.425	ns
Differential	2.192	2.58	2.434	2.864	2.425	2.852	2.164	2.545	2.156	2.536	ns

Table 116 • DDR1/SSTL2 Class I Transmitter Characteristics for MSIOD I/O Bank (Output and Tristate Buffers)

	T _{DP}		T _{ZL}		T _{ZH}		T _{HZ}		T _{LZ}		Unit
	-1	-Std	-1	-Std	-1	-Std	-1	-Std	-1	-Std	
Single-ended	1.512	1.779	1.462	1.72	1.462	1.72	1.676	1.972	1.676	1.971	ns
Differential	1.676	1.971	1.774	2.087	1.766	2.077	1.854	2.181	1.845	2.171	ns

Table 117 • DDR1/SSTL2 Class II Transmitter Characteristics for DDRIO I/O Bank (Output and Tristate Buffers)

	T _{DP}		T _{ZL}		T _{ZH}		T _{HZ}		T _{LZ}		Unit
	-1	-Std	-1	-Std	-1	-Std	-1	-Std	-1	-Std	
Single-ended	2.122	2.497	1.906	2.243	1.902	2.237	2.061	2.424	2.056	2.418	ns
Differential	2.127	2.501	2.042	2.402	2.043	2.403	2.363	2.78	2.365	2.781	ns

2.3.7.5 RSDS

Reduced Swing Differential Signaling (RSDS) is similar to an LVDS high-speed interface using differential signaling. RSDS has a similar implementation to LVDS devices and is only intended for point-to-point applications.

Minimum and Maximum Input and Output Levels

Table 203 • RSDS Recommended DC Operating Conditions

Parameter	Symbol	Min	Typ	Max	Unit
Supply voltage	V_{DDI}	2.375	2.5	2.625	V

Table 204 • RSDS DC Input Voltage Specification

Parameter	Symbol	Min	Max	Unit
DC input voltage	V_I	0	2.925	V

Table 205 • RSDS DC Output Voltage Specification

Parameter	Symbol	Min	Typ	Max	Unit
DC output logic high	V_{OH}	1.25	1.425	1.6	V
DC output logic low	V_{OL}	0.9	1.075	1.25	V

Table 206 • RSDS Differential Voltage Specification

Parameter	Symbol	Min	Max	Unit
Differential output voltage swing	V_{OD}	100	600	mV
Output common mode voltage	V_{OCM}	0.5	1.5	V
Input common mode voltage	V_{ICM}	0.3	1.5	V
Input differential voltage	V_{ID}	100	600	mV

Table 207 • RSDS Minimum and Maximum AC Switching Speed

Parameter	Symbol	Max	Unit	Conditions
Maximum data rate (for MSIO I/O bank)	D_{MAX}	520	Mbps	AC loading: 2 pF / 100 Ω differential load
Maximum data rate (for MSIOD I/O bank)	D_{MAX}	700	Mbps	AC loading: 2 pF / 100 Ω differential load

Table 208 • RSDS AC Impedance Specifications

Parameter	Symbol	Typ	Unit
Termination resistance	R_T	100	Ω

Table 209 • RSDS AC Test Parameter Specifications

Parameter	Symbol	Typ	Unit
Measuring/trip point for data path	V_{TRIP}	Cross point	V
Resistance for enable path (T_{ZH} , T_{ZL} , T_{HZ} , T_{LZ})	R_{ENT}	2K	Ω
Capacitive loading for enable path (T_{ZH} , T_{ZL} , T_{HZ} , T_{LZ})	C_{ENT}	5	pF

Table 215 • LVPECL DC Input Voltage Specification

Parameter	Symbol	Min	Max	Unit
DC input voltage	V_I	0	3.45	V

Table 216 • LVPECL DC Differential Voltage Specification

Parameter	Symbol	Min	Typ	Max	Unit
Input common mode voltage	V_{ICM}	0.3		2.8	V
Input differential voltage	V_{IDIFF}	100	300	1,000	mV

Table 217 • LVPECL Minimum and Maximum AC Switching Speeds

Parameter	Symbol	Max	Unit
Maximum data rate	D_{MAX}	900	Mbps

AC Switching Characteristics

Worst commercial-case conditions: $T_J = 85\text{ }^\circ\text{C}$, $V_{DD} = 1.14\text{ V}$, $V_{DDI} = 2.375\text{ V}$.

Table 218 • LVPECL Receiver Characteristics for MSIO I/O Bank

On-Die Termination (ODT)	T_{PY}		Unit
	-1	-Std	
None	2.572	3.025	ns
100	2.569	3.023	ns

2.3.8 I/O Register Specifications

This section describes input and output register specifications.

2.3.8.1 Input Register

Figure 6 • Timing Model for Input Register

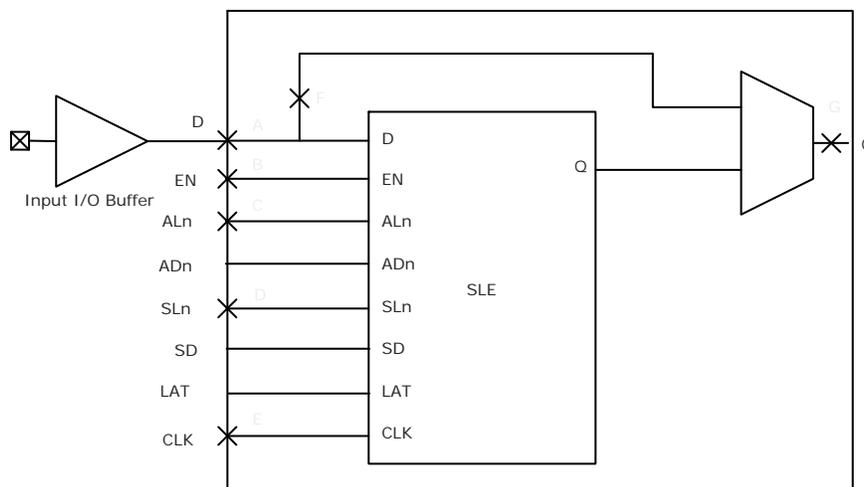

The following table lists the input data register propagation delays in worst commercial-case conditions when $T_J = 85\text{ }^\circ\text{C}$, $V_{DD} = 1.14\text{ V}$.

Table 219 • Input Data Register Propagation Delays

Parameter	Symbol	Measuring Nodes (from, to) ¹	-1		Unit
			-1	-Std	
Bypass delay of the input register	T_{IBYP}	F, G	0.353	0.415	ns
Clock-to-Q of the input register	T_{ICLKQ}	E, G	0.16	0.188	ns
Data setup time for the input register	T_{ISUD}	A, E	0.357	0.421	ns
Data hold time for the input register	T_{IHD}	A, E	0	0	ns
Enable setup time for the input register	T_{ISUE}	B, E	0.46	0.542	ns
Enable hold time for the input register	T_{IHE}	B, E	0	0	ns
Synchronous load setup time for the input register	T_{ISUSL}	D, E	0.46	0.542	ns
Synchronous load hold time for the input register	T_{IHSL}	D, E	0	0	ns
Asynchronous clear-to-Q of the input register (ADn=1)	T_{IALN2Q}	C, G	0.625	0.735	ns
Asynchronous preset-to-Q of the input register (ADn=0)		C, G	0.587	0.69	ns
Asynchronous load removal time for the input register	$T_{IREMALN}$	C, E	0	0	ns
Asynchronous load recovery time for the input register	$T_{IRECALN}$	C, E	0.074	0.087	ns
Asynchronous load minimum pulse width for the input register	T_{IWALN}	C, C	0.304	0.357	ns
Clock minimum pulse width high for the input register	$T_{ICKMPWH}$	E, E	0.075	0.088	ns
Clock minimum pulse width low for the input register	$T_{ICKMPWL}$	E, E	0.159	0.187	ns

1. For the derating values at specific junction temperature and voltage supply levels, see Table 16, page 14 for derating values.

The following table lists the 010 device global resources in worst commercial-case conditions when $T_J = 85\text{ }^\circ\text{C}$, $V_{DD} = 1.14\text{ V}$.

Table 229 • 010 Device Global Resource

Parameter	Symbol	-1		-Std		Unit
		Min	Max	Min	Max	
Input low delay for global clock	T_{RCKL}	0.626	0.669	0.627	0.668	ns
Input high delay for global clock	T_{RCKH}	1.112	1.182	1.308	1.393	ns
Maximum skew for global clock	T_{RCKSW}		0.07		0.085	ns

The following table lists the 005 device global resources in worst commercial-case conditions when $T_J = 85\text{ }^\circ\text{C}$, $V_{DD} = 1.14\text{ V}$.

Table 230 • 005 Device Global Resource

Parameter	Symbol	-1		-Std		Unit
		Min	Max	Min	Max	
Input low delay for global clock	T_{RCKL}	0.625	0.66	0.628	0.66	ns
Input high delay for global clock	T_{RCKH}	1.126	1.187	1.325	1.397	ns
Maximum skew for global clock	T_{RCKSW}		0.061		0.072	ns

2.3.12 FPGA Fabric SRAM

See *UG0445: IGLOO2 FPGA and SmartFusion2 SoC FPGA Fabric User Guide* for more information.

2.3.12.1 FPGA Fabric Large SRAM (LSRAM)

The following table lists the RAM1K18 – dual-port mode for depth \times width configuration $1\text{K} \times 18$ in worst commercial-case conditions when $T_J = 85\text{ }^\circ\text{C}$, $V_{DD} = 1.14\text{ V}$.

Table 231 • RAM1K18 – Dual-Port Mode for Depth \times Width Configuration $1\text{K} \times 18$

Parameter	Symbol	-1		-Std		Unit
		Min	Max	Min	Max	
Clock period	T_{CY}	2.5		2.941		ns
Clock minimum pulse width high	$T_{CLKMPWH}$	1.125		1.323		ns
Clock minimum pulse width low	$T_{CLKMPWL}$	1.125		1.323		ns
Pipelined clock period	T_{PLCY}	2.5		2.941		ns
Pipelined clock minimum pulse width high	$T_{PLCLKMPWH}$	1.125		1.323		ns
Pipelined clock minimum pulse width low	$T_{PLCLKMPWL}$	1.125		1.323		ns
Read access time with pipeline register				0.334	0.393	ns
Read access time without pipeline register	T_{CLK2Q}			2.273	2.674	ns
Access time with feed-through write timing				1.529	1.799	ns
Address setup time	T_{ADDRSU}	0.441		0.519		ns
Address hold time	T_{ADDRHD}	0.274		0.322		ns
Data setup time	T_{DSU}	0.341		0.401		ns
Data hold time	T_{DHD}	0.107		0.126		ns
Block select setup time	T_{BLKSU}	0.207		0.244		ns

Table 237 • μ SRAM (RAM64x18) in 64 × 18 Mode (continued)

Parameter	Symbol	-1		-Std		Unit
		Min	Max	Min	Max	
Write address setup time	$T_{ADDRCSU}$	0.088		0.104		ns
Write address hold time	$T_{ADDRCHD}$	0.128		0.15		ns
Write enable setup time	T_{WECSU}	0.397		0.467		ns
Write enable hold time	T_{WECHD}	-0.026		-0.03		ns
Maximum frequency	F_{MAX}		250		250	MHz

The following table lists the μ SRAM in 64 × 16 mode in worst commercial-case conditions when $T_J = 85\text{ }^\circ\text{C}$, $V_{DD} = 1.14\text{ V}$.

Table 238 • μ SRAM (RAM64x16) in 64 × 16 Mode

Parameter	Symbol	-1		-Std		Unit
		Min	Max	Min	Max	
Read clock period	T_{CY}	4		4		ns
Read clock minimum pulse width high	$T_{CLKMPWH}$	1.8		1.8		ns
Read clock minimum pulse width low	$T_{CLKMPWL}$	1.8		1.8		ns
Read pipeline clock period	T_{PLCY}	4		4		ns
Read pipeline clock minimum pulse width high	$T_{PLCLKMPWH}$	1.8		1.8		ns
Read pipeline clock minimum pulse width low	$T_{PLCLKMPWL}$	1.8		1.8		ns
Read access time with pipeline register	T_{CLK2Q}		0.266		0.313	ns
Read access time without pipeline register				1.677		1.973
Read address setup time in synchronous mode	T_{ADDRSU}	0.301		0.354		ns
Read address setup time in asynchronous mode			1.856		2.184	
Read address hold time in synchronous mode	T_{ADDRHD}	0.091		0.107		ns
Read address hold time in asynchronous mode			-0.778		-0.915	
Read enable setup time	T_{RDENSU}	0.278		0.327		ns
Read enable hold time	T_{RDENHD}	0.057		0.067		ns
Read block select setup time	T_{BLKSU}	1.839		2.163		ns
Read block select hold time	T_{BLKHD}	-0.65		-0.765		ns
Read block select to out disable time (when pipelined register is disabled)	T_{BLK2Q}		2.036		2.396	ns
Read asynchronous reset removal time (pipelined clock)	T_{RSTREM}	-0.023		-0.027		ns
Read asynchronous reset removal time (non-pipelined clock)			0.046		0.054	
Read asynchronous reset recovery time (pipelined clock)	T_{RSTREC}	0.507		0.597		ns
Read asynchronous reset recovery time (non-pipelined clock)			0.236		0.278	
Read asynchronous reset to output propagation delay (with pipelined register enabled)	T_{R2Q}		0.835		0.983	ns
Read synchronous reset setup time	T_{SRSTSU}	0.271		0.319		ns

Table 238 • μ SRAM (RAM64x16) in 64 x 16 Mode (continued)

Parameter	Symbol	-1		-Std		Unit
		Min	Max	Min	Max	
Read synchronous reset hold time	T_{SRSTHD}	0.061		0.071		ns
Write clock period	T_{CCY}	4		4		ns
Write clock minimum pulse width high	$T_{CCLKMPWH}$	1.8		1.8		ns
Write clock minimum pulse width low	$T_{CCLKMPWL}$	1.8		1.8		ns
Write block setup time	T_{BLKCSU}	0.404		0.476		ns
Write block hold time	T_{BLKCHD}	0.007		0.008		ns
Write input data setup time	T_{DINCSU}	0.115		0.135		ns
Write input data hold time	T_{DINCHD}	0.15		0.177		ns
Write address setup time	$T_{ADDRCSU}$	0.088		0.104		ns
Write address hold time	$T_{ADDRCHD}$	0.128		0.15		ns
Write enable setup time	T_{WECSU}	0.397		0.467		ns
Write enable hold time	T_{WECHD}	-0.026		-0.03		ns
Maximum frequency	F_{MAX}		250		250	MHz

The following table lists the μ SRAM in 128 x 9 mode in worst commercial-case conditions when $T_J = 85^\circ\text{C}$, $V_{DD} = 1.14\text{ V}$.

Table 239 • μ SRAM (RAM128x9) in 128 x 9 Mode

Parameter	Symbol	-1		-Std		Unit
		Min	Max	Min	Max	
Read clock period	T_{CY}	4		4		ns
Read clock minimum pulse width high	$T_{CLKMPWH}$	1.8		1.8		ns
Read clock minimum pulse width low	$T_{CLKMPWL}$	1.8		1.8		ns
Read pipeline clock period	T_{PLCY}	4		4		ns
Read pipeline clock minimum pulse width high	$T_{PLCLKMPWH}$	1.8		1.8		ns
Read pipeline clock minimum pulse width low	$T_{PLCLKMPWL}$	1.8		1.8		ns
Read access time with pipeline register	T_{CLK2Q}		0.266		0.313	ns
Read access time without pipeline register				1.677		1.973
Read address setup time in synchronous mode	T_{ADDRSU}	0.301		0.354		ns
Read address setup time in asynchronous mode			1.856		2.184	
Read address hold time in synchronous mode	T_{ADDRHD}	0.091		0.107		ns
Read address hold time in asynchronous mode			-0.778		-0.915	
Read enable setup time	T_{RDENSU}	0.278		0.327		ns
Read enable hold time	T_{RDENHD}	0.057		0.067		ns
Read block select setup time	T_{BLKSU}	1.839		2.163		ns
Read block select hold time	T_{BLKHD}	-0.65		-0.765		ns
Read block select to out disable time (when pipelined register is disabled)	T_{BLK2Q}		2.036		2.396	ns

Table 239 • μ SRAM (RAM128x9) in 128 × 9 Mode (continued)

Parameter	Symbol	-1		-Std		Unit
		Min	Max	Min	Max	
Read asynchronous reset removal time (pipelined clock)		-0.023		-0.027		ns
Read asynchronous reset removal time (non-pipelined clock)	T_{RSTREM}	0.046		0.054		ns
Read asynchronous reset recovery time (pipelined clock)		0.507		0.597		ns
Read asynchronous reset recovery time (non-pipelined clock)	T_{RSTREC}	0.236		0.278		ns
Read asynchronous reset to output propagation delay (with pipelined register enabled)	T_{R2Q}		0.835		0.982	ns
Read synchronous reset setup time	T_{SRSTSU}	0.271		0.319		ns
Read synchronous reset hold time	T_{SRSTHD}	0.061		0.071		ns
Write clock period	T_{CCY}	4		4		ns
Write clock minimum pulse width high	$T_{CCLKMPWH}$	1.8		1.8		ns
Write clock minimum pulse width low	$T_{CCLKMPWL}$	1.8		1.8		ns
Write block setup time	T_{BLKCSU}	0.404		0.476		ns
Write block hold time	T_{BLKCHD}	0.007		0.008		ns
Write input data setup time	T_{DINCSU}	0.115		0.135		ns
Write input data hold time	T_{DINCHD}	0.15		0.177		ns
Write address setup time	$T_{ADDRCSU}$	0.088		0.104		ns
Write address hold time	$T_{ADDRCHD}$	0.128		0.15		ns
Write enable setup time	T_{WECSU}	0.397		0.467		ns
Write enable hold time	T_{WECHD}	-0.026		-0.03		ns
Maximum frequency	F_{MAX}		250		250	MHz

The following table lists the μ SRAM in 128 × 8 mode in worst commercial-case conditions when $T_J = 85^\circ\text{C}$, $V_{DD} = 1.14\text{ V}$.

Table 240 • μ SRAM (RAM128x8) in 128 × 8 Mode

Parameter	Symbol	-1		-Std		Unit
		Min	Max	Min	Max	
Read clock period	T_{CY}	4		4		ns
Read clock minimum pulse width high	$T_{CLKMPWH}$	1.8		1.8		ns
Read clock minimum pulse width low	$T_{CLKMPWL}$	1.8		1.8		ns
Read pipeline clock period	T_{PLCY}	4		4		ns
Read pipeline clock minimum pulse width high	$T_{PLCLKMPWH}$	1.8		1.8		ns
Read pipeline clock minimum pulse width low	$T_{PLCLKMPWL}$	1.8		1.8		ns
Read access time with pipeline register			0.266		0.313	ns
Read access time without pipeline register	T_{CLK2Q}		1.677		1.973	ns
Read address setup time in synchronous mode		0.301		0.354		ns
Read address setup time in asynchronous mode	T_{ADDRSU}	1.856		2.184		ns

Table 248 • 2 Step IAP Programming (eNVM Only)

M2S/M2GL					
Device	Image size Bytes	Authenticate	Program	Verify	Unit
005	137536	2	37	5	Sec
010	274816	4	76	11	Sec
025	274816	4	78	10	Sec
050	278528	3	85	9	Sec
060	268480	5	76	22	Sec
090	544496	10	152	43	Sec
150	544496	10	153	44	Sec

Table 249 • 2 Step IAP Programming (Fabric and eNVM)

M2S/M2GL					
Device	Image size Bytes	Authenticate	Program	Verify	Unit
005	439296	6	56	11	Sec
010	842688	11	100	21	Sec
025	1497408	19	113	32	Sec
050	2695168	32	136	48	Sec
060	2686464	43	137	70	Sec
090	4190208	68	236	115	Sec
150	6682768	109	286	162	Sec

Table 250 • SmartFusion2 Cortex-M3 ISP Programming (Fabric Only)

M2S/M2GL					
Device	Image size Bytes	Authenticate	Program	Verify	Unit
005	302672	6	19	8	Sec
010	568784	10	26	14	Sec
025	1223504	21	39	29	Sec
050	2424832	39	60	50	Sec
060	2418896	44	65	54	Sec
090	3645968	66	90	79	Sec
150	6139184	108	140	128	Sec

Table 251 • SmartFusion2 Cortex-M3 ISP Programming (eNVM Only)

M2S/M2GL					
Device	Image size Bytes	Authenticate	Program	Verify	Unit
005	137536	3	42	4	Sec
010	274816	4	82	7	Sec
025	274816	4	82	8	Sec
050	278528	4	80	8	Sec
060	268480	6	80	8	Sec
090	544496	10	157	15	Sec

Table 251 • SmartFusion2 Cortex-M3 ISP Programming (eNVM Only) (continued)

M2S/M2GL Device	Image size Bytes	Authenticate	Program	Verify	Unit
150	544496	10	158	15	Sec

Table 252 • SmartFusion2 Cortex-M3 ISP Programming (Fabric and eNVM)

M2S/M2GL Device	Image size Bytes	Authenticate	Program	Verify	Unit
005	439296	9	61	11	Sec
010	842688	15	107	21	Sec
025	1497408	26	121	35	Sec
050	2695168	43	141	55	Sec
060	2686464	48	143	60	Sec
090	4190208	75	244	91	Sec
150	6682768	117	296	141	Sec

Table 253 • Programming Times with 100 kHz, 25 MHz, and 12.5 MHz SPI Clock Rates (Fabric Only)

M2S/M2GL Device	Auto Programming	Auto Update	Programming Recovery	Unit
	100 kHz	25 MHz	12.5 MHz	
005	47	27	28	Sec
010	77	35	35	Sec
025	150	42	41	Sec
050	33 ¹	Not Supported	Not Supported	Sec
060	291	83	82	Sec
090	427	109	108	Sec
150	708	157	160	Sec

1. Auto Programming in 050 device is done through SC_SPI, and SPI CLK is set to 6.25 MHz.

Table 254 • Programming Times with 100 kHz, 25 MHz, and 12.5 MHz SPI Clock Rates (eNVM Only)

M2S/M2GL Device	Auto Programming	Auto Update	Programming Recovery	Unit
	100 kHz	25 MHz	12.5 MHz	
005	41	48	49	Sec
010	86	87	87	Sec
025	87	85	86	Sec
050	85	Not Supported	Not Supported	Sec
060	78	86	86	Sec
090	154	162	162	Sec

The following table lists the math blocks with input register used and output in bypass mode in worst commercial-case conditions when $T_J = 85\text{ }^\circ\text{C}$, $V_{DD} = 1.14\text{ V}$.

Table 270 • Math Block with Input Register Used and Output in Bypass Mode

Parameter	Symbol	-1		-Std		Unit
		Min	Max	Min	Max	
Input register setup time	T_{MISU}	0.149		0.176		ns
Input register hold time	T_{MIHD}	0.185		0.218		ns
Synchronous reset/enable setup time	$T_{MSRSTENSU}$	0.08		0.094		ns
Synchronous reset/enable hold time	$T_{MSRSTENHD}$	-0.012		-0.014		ns
Asynchronous reset removal time	$T_{MARSTREM}$	-0.005		-0.005		ns
Asynchronous reset recovery time	$T_{MARSTREC}$	0.088		0.104		ns
Input register clock to output delay	T_{MICQ}		2.52		2.964	ns
CDIN to output delay	$T_{MCDIN2Q}$		1.951		2.295	ns

The following table lists the math blocks with input and output in bypass mode in worst commercial-case conditions when $T_J = 85\text{ }^\circ\text{C}$, $V_{DD} = 1.14\text{ V}$.

Table 271 • Math Block with Input and Output in Bypass Mode

Parameter	Symbol	-1	-Std	Unit
		Max	Max	
Input to output delay	T_{MIQ}	2.568	3.022	ns
CDIN to output delay	$T_{MCDIN2Q}$	1.951	2.295	ns

2.3.15 Embedded NVM (eNVM) Characteristics

The following table lists the eNVM read performance in worst-case conditions when $V_{DD} = 1.14\text{ V}$, $V_{PPNVM} = V_{PP} = 2.375\text{ V}$.

Table 272 • eNVM Read Performance

Symbol	Description	Operating Temperature Range						Unit
		-1	-Std	-1	-Std	-1	-Std	
T_J	Junction temperature range	-55 °C to 125 °C		-40 °C to 100 °C		0 °C to 85 °C		°C
$F_{MAXREAD}$	eNVM maximum read frequency	25	25	25	25	25	25	MHz

The following table lists the eNVM page programming in worst-case conditions when $V_{DD} = 1.14\text{ V}$, $V_{PPNVM} = V_{PP} = 2.375\text{ V}$.

Table 273 • eNVM Page Programming

Symbol	Description	Operating Temperature Range						Unit
		-1	-Std	-1	-Std	-1	-Std	
T_J	Junction temperature range	-55 °C to 125 °C		-40 °C to 100 °C		0 °C to 85 °C		°C
$T_{PAGEPGM}$	eNVM page programming time	40	40	40	40	40	40	ms

Figure 22 • SPI Timing for a Single Frame Transfer in Motorola Mode (SPH = 1)

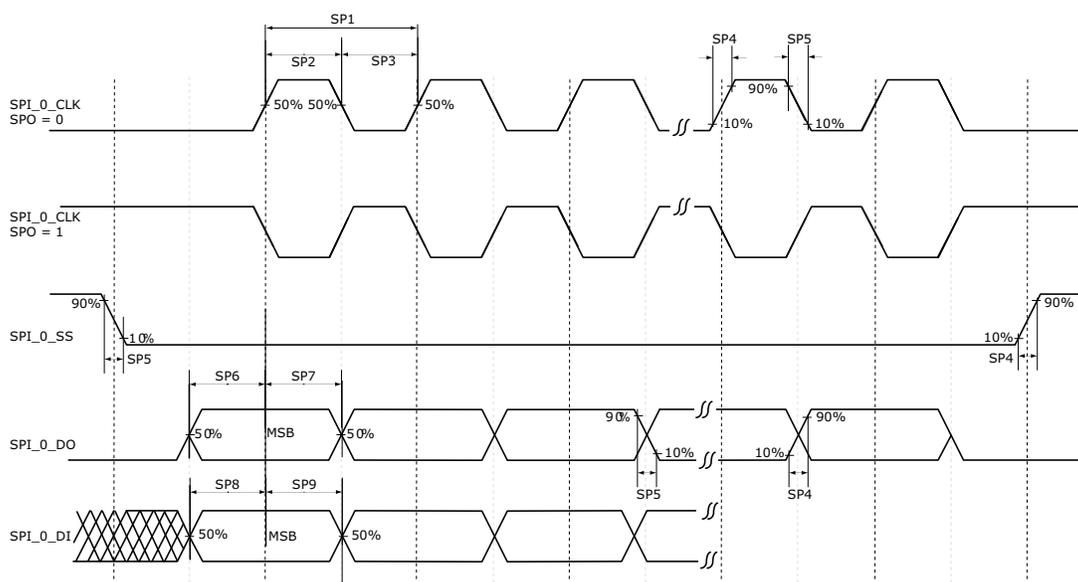

2.3.32 CAN Controller Characteristics

The following table lists the CAN controller characteristics in worst-case industrial conditions when $T_J = 100\text{ }^\circ\text{C}$, $V_{DD} = 1.14\text{ V}$.

Table 306 • CAN Controller Characteristics

Parameter	Description	-1	-Std	Unit
FCANREFCLK ¹	Internally sourced CAN reference clock frequency	160	136	MHz
BAUDCANMAX	Maximum CAN performance baud rate	1	1	Mbps
BAUDCANMIN	Minimum CAN performance baud rate	0.05	0.05	Mbps

1. PCLK to CAN controller must be a multiple of 8 MHz.

2.3.33 USB Characteristics

The following table lists the USB characteristics in worst-case industrial conditions when $T_J = 100\text{ }^\circ\text{C}$, $V_{DD} = 1.14\text{ V}$.

Table 307 • USB Characteristics

Parameter	Description	-1	-Std	Unit
FUSBREFCLK	Internally sourced USB reference clock frequency	166	142	MHz
TUSBCLK	USB clock period	16.66	16.66	ns
TUSBPD	Clock to USB data propagation delay	9.0	9.0	ns
TUSBSU	Setup time for USB data	6.0	6.0	ns
TUSBHD	Hold time for USB data	0	0	ns

2.3.34 MMUART Characteristics

The following table lists the MMUART characteristics in worst-case industrial conditions when $T_J = 100\text{ }^\circ\text{C}$, $V_{DD} = 1.14\text{ V}$.

Table 308 • MMUART Characteristics

Parameter	Description	-1	-Std	Unit
FMMUART_REF_CLK	Internally sourced MMUART reference clock frequency.	166	142	MHz
BAUDMMUARTTx	Maximum transmit baud rate	10.375	8.875	Mbps
BAUDMMUARTRx	Maximum receive baud rate	10.375	8.875	Mbps

2.3.35 IGLOO2 Specifications

2.3.35.1 HPMS Clock Frequency

The following table lists the maximum frequency for HPMS main clock in worst-case industrial conditions when $T_J = 100\text{ }^\circ\text{C}$, $V_{DD} = 1.14\text{ V}$.

Table 309 • Maximum Frequency for HPMS Main Clock

Symbol	Description	-1	-Std	Unit
HPMS_CLK	Maximum frequency for the HPMS main clock	166	142	MHz

2.3.35.2 IGLOO2 Serial Peripheral Interface (SPI) Characteristics

This section describes the DC and switching of the SPI interface. Unless otherwise noted, all output characteristics given are for a 35 pF load on the pins and all sequential timing characteristics are related to SPI_0_CLK. For timing parameter definitions, see Figure 23, page 131.

The following table lists the SPI characteristics in worst-case industrial conditions when $T_J = 100\text{ }^\circ\text{C}$, $V_{DD} = 1.14\text{ V}$.

Table 310 • SPI Characteristics for All Devices

Symbol	Description	Min	Typ	Max	Unit	Conditions
SPIFMAX	Maximum operating frequency of SPI interface			20	MHz	
sp1	SPI_[0 1]_CLK minimum period					
	SPI_[0 1]_CLK = PCLK/2	12			ns	
	SPI_[0 1]_CLK = PCLK/4	24.1			ns	
	SPI_[0 1]_CLK = PCLK/8	48.2			ns	
	SPI_[0 1]_CLK = PCLK/16	0.1			μs	
	SPI_[0 1]_CLK = PCLK/32	0.19			μs	
	SPI_[0 1]_CLK = PCLK/64	0.39			μs	
SPI_[0 1]_CLK = PCLK/128	0.77			μs		

Table 310 • SPI Characteristics for All Devices (continued)

Symbol	Description	Min	Typ	Max	Unit	Conditions
sp2	SPI_[0 1]_CLK minimum pulse width high					
	SPI_[0 1]_CLK = PCLK/2	6			ns	
	SPI_[0 1]_CLK = PCLK/4	12.05			ns	
	SPI_[0 1]_CLK = PCLK/8	24.1			ns	
	SPI_[0 1]_CLK = PCLK/16	0.05			µs	
	SPI_[0 1]_CLK = PCLK/32	0.095			µs	
	SPI_[0 1]_CLK = PCLK/64	0.195			µs	
	SPI_[0 1]_CLK = PCLK/128	0.385			µs	
sp3	SPI_[0 1]_CLK minimum pulse width low					
	SPI_[0 1]_CLK = PCLK/2	6			ns	
	SPI_[0 1]_CLK = PCLK/4	12.05			ns	
	SPI_[0 1]_CLK = PCLK/8	24.1			ns	
	SPI_[0 1]_CLK = PCLK/16	0.05			µs	
	SPI_[0 1]_CLK = PCLK/32	0.095			µs	
	SPI_[0 1]_CLK = PCLK/64	0.195			µs	
	SPI_[0 1]_CLK = PCLK/128	0.385			µs	
sp4	SPI_[0 1]_CLK, SPI_[0 1]_DO, SPI_[0 1]_SS rise time (10%–90%) ¹		2.77		ns	I/O Configuration: LVCMOS 2.5 V - 8 mA AC loading: 35 pF test conditions: Typical voltage, 25 °C
sp5	SPI_[0 1]_CLK, SPI_[0 1]_DO, SPI_[0 1]_SS fall time (10%–90%) ¹		2.906		ns	I/O Configuration: LVCMOS 2.5 V - 8 mA AC loading: 35 pF test conditions: Typical voltage, 25 °C
SPI master configuration (applicable for 005, 010, 025, and 050 devices)						
sp6m	SPI_[0 1]_DO setup time ²	(SPI_x_CLK_period/2) – 8.0			ns	
sp7m	SPI_[0 1]_DO hold time ²	(SPI_x_CLK_period/2) – 2.5			ns	
sp8m	SPI_[0 1]_DI setup time ²	12			ns	
sp9m	SPI_[0 1]_DI hold time ²	2.5			ns	
SPI slave configuration (applicable for 005, 010, 025, and 050 devices)						
sp6s	SPI_[0 1]_DO setup time ²	(SPI_x_CLK_period/2) – 17.0			ns	
sp7s	SPI_[0 1]_DO hold time ²	(SPI_x_CLK_period/2) + 3.0			ns	
sp8s	SPI_[0 1]_DI setup time ²	2			ns	
sp9s	SPI_[0 1]_DI hold time ²	7			ns	