



Welcome to [E-XFL.COM](https://www.e-xfl.com)

Embedded - System On Chip (SoC): The Heart of Modern Embedded Systems

Embedded - System On Chip (SoC) refers to an integrated circuit that consolidates all the essential components of a computer system into a single chip. This includes a microprocessor, memory, and other peripherals, all packed into one compact and efficient package. SoCs are designed to provide a complete computing solution, optimizing both space and power consumption, making them ideal for a wide range of embedded applications.

What are Embedded - System On Chip (SoC)?

System On Chip (SoC) integrates multiple functions of a computer or electronic system onto a single chip. Unlike traditional multi-chip solutions, SoCs combine a central

Details

Product Status	Active
Architecture	MCU, FPGA
Core Processor	ARM® Cortex®-M3
Flash Size	256KB
RAM Size	64KB
Peripherals	DDR, PCIe, SERDES
Connectivity	CANbus, Ethernet, I ² C, SPI, UART/USART, USB
Speed	166MHz
Primary Attributes	FPGA - 50K Logic Modules
Operating Temperature	0°C ~ 85°C (TJ)
Package / Case	484-BGA
Supplier Device Package	484-FPBGA (23x23)
Purchase URL	https://www.e-xfl.com/product-detail/microchip-technology/m2s050t-fg484

Table 4 • Recommended Operating Conditions (continued)

Parameter	Symbol	Min	Typ	Max	Unit	Conditions
3.3 V DC supply voltage	V_{DDIX}	3.15	3.3	3.45	V	
LVDS differential I/O	V_{DDIX}	2.375	2.5	3.45	V	
B-LVDS, M-LVDS, Mini-LVDS, RSDS differential I/O	V_{DDIX}	2.375	2.5	2.625	V	
LVPECL differential I/O	V_{DDIX}	3.15	3.3	3.45	V	
Reference voltage supply for FDDR (Bank0) and MDDR (Bank5)	V_{REFX}	$0.49 \times V_{DDIX}$	$0.5 \times V_{DDIX}$	$0.51 \times V_{DDIX}$	V	
Analog sense circuit supply of embedded nonvolatile memory (eNVM). Must be shorted to V_{PP} .	V_{PPNVM}	2.375	2.5	2.625	V	2.5 V range
		3.15	3.3	3.45	V	3.3 V range

1. Programming at Industrial temperature range is available only with $V_{PP} = 3.3$ V.

Note: Power supply ramps must all be strictly monotonic, without plateaus.

Table 5 • FPGA Operating Limits

Product Grade	Element	Programming Temperature	Operating Temperature	Programming Cycles	Digest Temperature	Digest Cycles	Retention (Biased/Unbiased)
Commercial	FPGA	Min $T_J = 0$ °C Max $T_J = 85$ °C	Min $T_J = 0$ °C Max $T_J = 85$ °C	500	Min $T_J = 0$ °C Max $T_J = 85$ °C	2000	20 years
Industrial ¹	FPGA	Min $T_J = -40$ °C Max $T_J = 100$ °C	Min $T_J = -40$ °C Max $T_J = 100$ °C	500	Min $T_J = -40$ °C Max $T_J = 100$ °C	2000	20 years

1. Programming at Industrial temperature range is available only with $V_{PP} = 3.3$ V.

Note: The retention specification is defined as the total number of programming and digest cycles. For example, 20 years of retention after 500 programming cycles.

Note: The digest cycle specification is 2000 digest cycles for every program cycle with a maximum of 500 programming cycles.

Note: If your product qualification requires accelerated programming cycles, see *Microsemi SoC Products Quality and Reliability Report* about recommended methodologies.

where

- θ_{JA} = Junction-to-air thermal resistance
- θ_{JB} = Junction-to-board thermal resistance
- θ_{JC} = Junction-to-case thermal resistance
- T_J = Junction temperature
- T_A = Ambient temperature
- T_B = Board temperature (measured 1.0 mm away from the package edge)
- T_C = Case temperature
- P = Total power dissipated by the device

Table 9 • Package Thermal Resistance of SmartFusion2 and IGLOO2 Devices

Device	Still Air	1.0 m/s	2.5 m/s	θ_{JB}	θ_{JC}	Unit
	θ_{JA}					
005						
FG484	19.36	15.81	14.63	9.74	5.27	°C/W
VF256	41.30	38.16	35.30	28.41	3.94	°C/W
VF400	20.19	16.94	15.41	8.86	4.95	°C/W
TQ144	42.80	36.80	34.50	37.20	10.80	°C/W
010						
FG484	18.22	14.83	13.62	8.83	4.92	°C/W
VF256	37.36	34.26	31.45	24.84	7.89	°C/W
VF400	19.40	15.75	14.22	8.11	4.22	°C/W
TQ144	38.60	32.60	30.30	31.80	8.60	°C/W
025						
FG484	17.03	13.66	12.45	7.66	4.18	°C/W
VF256	33.85	30.59	27.85	21.63	6.13	°C/W
VF400	18.36	14.89	13.36	7.12	3.41	°C/W
FCS325	29.17	24.87	23.12	14.44	2.31	°C/W
050						
FG484	15.29	12.19	10.99	6.27	3.24	°C/W
FG896	14.70	12.50	10.90	7.20	4.90	°C/W
VF400	17.53	14.17	12.63	6.32	2.81	°C/W
FCS325	27.38	23.18	21.41	12.47	1.59	°C/W
060						
FG484	15.40	12.06	10.85	6.14	3.15	°C/W
FG676	15.49	12.21	11.06	7.07	3.87	°C/W
VF400	17.45	14.01	12.47	6.22	2.69	°C/W
FCS325	27.03	22.91	21.25	12.33	1.54	°C/W
090						
FG484	14.64	11.37	10.16	5.43	2.77	°C/W
FG676	14.52	11.19	10.37	6.17	3.24	°C/W
FCS325	26.63	22.26	20.13	14.24	2.50	°C/W

2.3.5.3 Tristate Buffer and AC Loading

The tristate path for enable path loadings is described in the respective specifications. The following figure shows the methodology of characterization illustrated by the enable path test point.

Figure 5 • Tristate Buffer for Enable Path Test Point

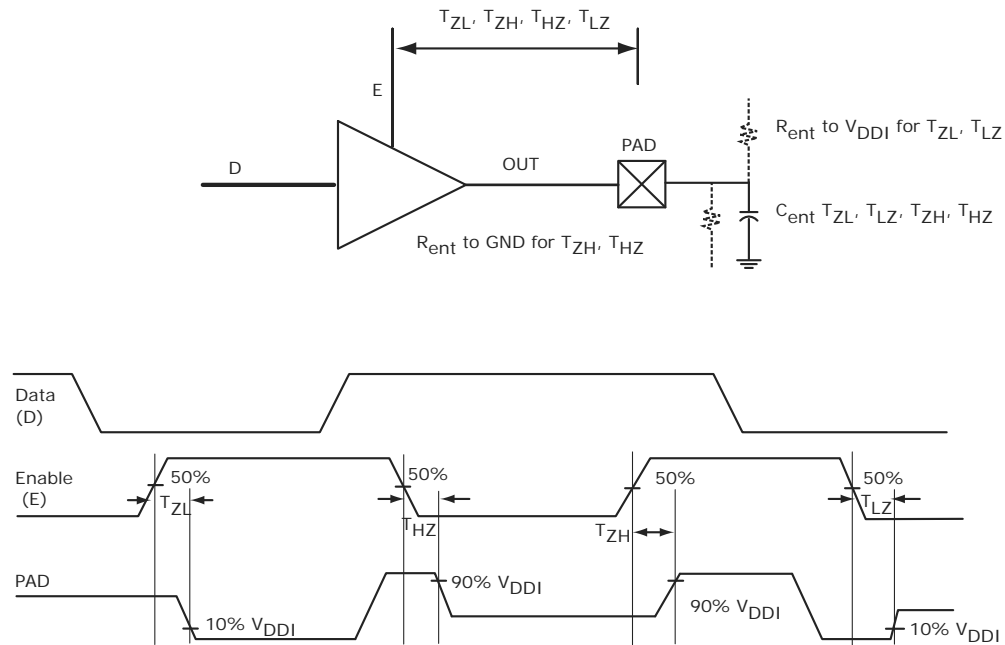

2.3.5.4 I/O Speeds

This section describes the maximum data rate summary of I/O in worst-case industrial conditions. See the individual I/O standards for operating conditions.

Table 18 • Maximum Data Rate Summary Table for Single-Ended I/O in Worst-Case Industrial Conditions

I/O	MSIO	MSIOD	DDRIO	Unit
PCI 3.3 V	630			Mbps
LVTTL 3.3 V	600			Mbps
LVC MOS 3.3 V	600			Mbps
LVC MOS 2.5 V	410	420	400	Mbps
LVC MOS 1.8 V	295	400	400	Mbps
LVC MOS 1.5 V	160	220	235	Mbps
LVC MOS 1.2 V	120	160	200	Mbps
LPDDR-LVC MOS 1.8 V mode			400	Mbps

2.3.5.6 Single-Ended I/O Standards

2.3.5.6.1 Low Voltage Complementary Metal Oxide Semiconductor (LVCMOS)

LVCMOS is a widely used switching standard implemented in CMOS transistors. This standard is defined by JEDEC (JESD 8-5). The LVCMOS standards supported in IGLOO2 FPGAs and SmartFusion2 SoC FPGAs are: LVCMOS12, LVCMOS15, LVCMOS18, LVCMOS25, and LVCMOS33.

2.3.5.6.2 3.3 V LVCMOS/LVTTL

LVCMOS 3.3 V or Low-Voltage Transistor-Transistor Logic (LVTTL) is a general standard for 3.3 V applications.

Minimum and Maximum DC/AC Input and Output Levels Specification

Table 29 • LVTTL/LVCMOS 3.3 V DC Recommended DC Operating Conditions (Applicable to MSIO I/O Bank Only)

Parameter	Symbol	Min	Typ	Max	Unit
Supply voltage	V_{DDI}	3.15	3.3	3.45	V

Table 30 • LVTTL/LVCMOS 3.3 V Input Voltage Specification (Applicable to MSIO I/O Bank Only)

Parameter	Symbol	Min	Max	Unit
DC input logic high	V_{IH} (DC)	2.0	3.45	V
DC input logic low	V_{IL} (DC)	-0.3	0.8	V
Input current high ¹	I_{IH} (DC)			
Input current low ¹	I_{IL} (DC)			

1. See Table 24, page 22.

Table 31 • LVCMOS 3.3 V DC Output Voltage Specification (Applicable to MSIO I/O Bank Only)

Parameter	Symbol	Min	Max	Unit
DC output logic high ¹	V_{OH}	$V_{DDI} - 0.4$		V
DC output logic low ¹	V_{OL}		0.4	V

1. The V_{OH}/V_{OL} test points selected ensure compliance with LVCMOS 3.3 V JESD8-B requirements.

Table 32 • LVTTL 3.3 V DC Output Voltage Specification (Applicable to MSIO I/O Bank Only)

Parameter	Symbol	Min	Max	Unit
DC output logic high	V_{OH}	2.4		V
DC output logic low	V_{OL}		0.4	V

Table 33 • LVTTL/LVCMOS 3.3 V AC Maximum Switching Speed (Applicable to MSIO I/O Bank Only)

Parameter	Symbol	Max	Unit	Conditions
Maximum data rate (for MSIO I/O bank)	D_{MAX}	600	Mbps	AC loading: 17 pF load, maximum drive/slew

Table 48 • LVCMOS 2.5 V Transmitter Characteristics for MSIOD Bank (Output and Tristate Buffers)

Output Drive Selection	Slew Control	T_{DP}		T_{ZL}		T_{ZH}		T_{HZ}^1		T_{LZ}^1		Unit
		-1	-Std	-1	-Std	-1	-Std	-1	-Std	-1	-Std	
2 mA	Slow	2.206	2.596	2.678	3.15	2.64	3.106	4.935	5.805	4.74	5.576	ns
4 mA	Slow	1.835	2.159	2.242	2.637	2.256	2.654	5.413	6.368	5.15	6.059	ns
6 mA	Slow	1.709	2.01	2.132	2.508	2.167	2.549	5.813	6.838	5.499	6.469	ns
8 mA	Slow	1.63	1.918	1.958	2.303	2.012	2.367	6.226	7.324	5.816	6.842	ns
12 mA	Slow	1.648	1.939	1.86	2.187	1.921	2.259	6.519	7.669	6.027	7.09	ns

1. Delay increases with drive strength are inherent to built-in slew control circuitry for simultaneous switching output (SSO) management.

2.3.5.8 1.8 V LVCMOS

LVCMOS 1.8 is a general standard for 1.8 V applications and is supported in IGLOO2 FPGAs and SmartFusion2 SoC FPGAs in compliance to the JEDEC specification JESD8-7A.

Minimum and Maximum DC/AC Input and Output Levels Specification

Table 49 • LVCMOS 1.8 V DC Recommended Operating Conditions

Parameter	Symbol	Min	Typ	Max	Unit
LVCMOS 1.8 V DC Recommended Operating Conditions					
Supply voltage	V_{DDI}	1.710	1.8	1.89	V

Table 50 • LVCMOS 1.8 V DC Input Voltage Specification

Parameter	Symbol	Min	Max	Unit
DC input logic high (for MSIOD and DDRIO I/O banks)	V_{IH} (DC)	$0.65 \times V_{DDI}$	1.89	V
DC input logic high (for MSIO I/O bank)	V_{IH} (DC)	$0.65 \times V_{DDI}$	3.45	V
DC input logic low	V_{IL} (DC)	-0.3	$0.35 \times V_{DDI}$	V
Input current high ¹	I_{IH} (DC)			-
Input current low ¹	I_{IL} (DC)			-

1. See Table 24, page 22.

Table 51 • LVCMOS 1.8 V DC Output Voltage Specification

Parameter	Symbol	Min	Max	Unit
DC output logic high	V_{OH}	$V_{DDI} - 0.45$		V
DC output logic low	V_{OL}		0.45	V

Table 52 • LVCMOS 1.8 V Minimum and Maximum AC Switching Speed

Parameter	Symbol	Max	Unit	Conditions
Maximum data rate (for DDRIO I/O bank) ¹	D_{MAX}	400	Mbps	AC loading: 17 pF load, maximum drive/slew
Maximum data rate (for MSIO I/O bank)	D_{MAX}	295	Mbps	AC loading: 17 pF load, maximum drive/slew
Maximum data rate (for MSIOD I/O bank) ¹	D_{MAX}	400	Mbps	AC loading: 17 pF load, maximum drive/slew

1. Maximum Data Rate applies for Drive Strength 8 mA and above, All Slews.

Table 58 • LVCMOS 1.8 V Transmitter Characteristics for MSIO I/O Bank

Output Drive Selection	Slew Control	T _{DP}		T _{ZL}		T _{ZH}		T _{HZ} ¹		T _{LZ} ¹		Unit
		-1	-Std	-1	-Std	-1	-Std	-1	-Std	-1	-Std	
2 mA	Slow	3.441	4.047	4.165	4.9	4.413	5.192	4.891	5.755	5.138	6.044	ns
4 mA	Slow	3.218	3.786	3.642	4.284	3.941	4.636	5.665	6.665	5.568	6.551	ns
6 mA	Slow	3.141	3.694	3.501	4.118	3.823	4.498	6.587	7.75	6.032	7.096	ns
8 mA	Slow	3.165	3.723	3.319	3.904	3.654	4.298	6.898	8.115	6.216	7.313	ns
10 mA	Slow	3.202	3.767	3.278	3.857	3.616	4.254	7.25	8.529	6.435	7.571	ns
12 mA	Slow	3.277	3.855	3.175	3.736	3.519	4.139	7.392	8.697	6.538	7.692	ns

1. Delay increases with drive strength are inherent to built-in slew control circuitry for simultaneous switching output (SSO) management.

Table 59 • LVCMOS 1.8 V Transmitter Characteristics for MSIOD I/O Bank

Output Drive Selection	Slew Control	T _{DP}		T _{ZL}		T _{ZH}		T _{HZ} ¹		T _{LZ} ¹		Unit
		-1	-Std	-1	-Std	-1	-Std	-1	-Std	-1	-Std	
2 mA	Slow	2.725	3.206	3.316	3.901	3.484	4.099	5.204	6.123	4.997	5.88	ns
4 mA	Slow	2.242	2.638	2.777	3.267	2.947	3.466	5.729	6.74	5.448	6.41	ns
6 mA	Slow	1.995	2.347	2.466	2.901	2.63	3.094	6.372	7.496	5.987	7.043	ns
8 mA	Slow	2.001	2.354	2.44	2.87	2.6	3.058	6.633	7.804	6.193	7.286	ns
10 mA	Slow	2.025	2.382	2.312	2.719	2.47	2.906	6.94	8.165	6.412	7.544	ns

1. Delay increases with drive strength are inherent to built-in slew control circuitry for simultaneous switching output (SSO) management.

2.3.5.9 1.5 V LVCMOS

LVCMOS 1.5 is a general standard for 1.5 V applications and is supported in IGLOO2 FPGAs and SmartFusion2 SoC FPGAs in compliance to the JEDEC specification JESD8-11A.

Minimum and Maximum DC/AC Input and Output Levels Specification

Table 60 • LVCMOS 1.5 V DC Recommended Operating Conditions

Parameter	Symbol	Min	Typ	Max	Unit
Supply voltage	V _{DDI}	1.425	1.5	1.575	V

Table 61 • LVCMOS 1.5 V DC Input Voltage Specification

Parameter	Symbol	Min	Max	Unit
DC input logic high for (MSIOD and DDRIO I/O banks)	V _{IH} (DC)	0.65 × V _{DDI}	1.575	V
DC input logic high (for MSIO I/O bank)	V _{IH} (DC)	0.65 × V _{DDI}	3.45	V
DC input logic low	V _{IL} (DC)	-0.3	0.35 × V _{DDI}	V
Input current high ¹	I _{IH} (DC)			-
Input current low ¹	I _{IL} (DC)			-

1. See Table 24, page 22.

Table 70 • LVCMOS 1.5 V Transmitter Characteristics for DDRIO I/O Bank (Output and Tristate Buffers)
(continued)

Output Drive Selection	Slew Control	T _{DP}		T _{ZL}		T _{ZH}		T _{HZ} ¹		T _{LZ} ¹		Unit
		-1	-Std	-1	-Std	-1	-Std	-1	-Std	-1	-Std	
6 mA	Slow	4.244	4.993	3.465	4.076	4.233	4.979	6.39	7.518	5.736	6.748	ns
	Medium	3.774	4.44	3.05	3.587	3.762	4.426	6.114	7.193	5.397	6.35	ns
	Medium fast	3.544	4.17	2.839	3.339	3.529	4.152	5.978	7.033	5.27	6.2	ns
	Fast	3.519	4.14	2.82	3.317	3.504	4.122	5.965	7.017	5.259	6.187	ns
8 mA	Slow	4.099	4.823	3.311	3.894	4.087	4.807	6.584	7.746	5.854	6.888	ns
	Medium	3.656	4.301	2.927	3.443	3.642	4.284	6.311	7.425	5.553	6.533	ns
	Medium fast	3.437	4.044	2.731	3.213	3.42	4.023	6.182	7.273	5.435	6.394	ns
	Fast	3.41	4.012	2.715	3.193	3.393	3.991	6.178	7.269	5.425	6.383	ns
10 mA	Slow	4.029	4.74	3.238	3.809	4.015	4.723	6.732	7.921	5.965	7.018	ns
	Medium	3.601	4.237	2.867	3.372	3.586	4.218	6.473	7.615	5.669	6.669	ns
	Medium fast	3.384	3.981	2.672	3.143	3.365	3.958	6.351	7.471	5.55	6.529	ns
	Fast	3.357	3.949	2.655	3.123	3.338	3.927	6.345	7.464	5.54	6.518	ns
12 mA	Slow	3.974	4.675	3.196	3.759	3.958	4.656	6.842	8.049	6.068	7.139	ns
	Medium	3.55	4.176	2.827	3.326	3.534	4.157	6.584	7.746	5.751	6.766	ns
	Medium fast	3.345	3.935	2.638	3.103	3.325	3.911	6.488	7.633	5.641	6.637	ns
	Fast	3.316	3.902	2.621	3.083	3.297	3.878	6.486	7.63	5.626	6.619	ns

1. Delay increases with drive strength are inherent to built-in slew control circuitry for simultaneous switching output (SSO) management.

Table 71 • LVCMOS 1.5 V Transmitter Characteristics for MSIO I/O Bank (Output and Tristate Buffers)

Output Drive Selection	Slew Control	T _{DP}		T _{ZL}		T _{ZH}		T _{HZ} ¹		T _{LZ} ¹		Unit
		-1	-Std	-1	-Std	-1	-Std	-1	-Std	-1	-Std	
2 mA	Slow	4.423	5.203	5.397	6.35	5.686	6.69	5.609	6.599	5.561	6.542	ns
4 mA	Slow	4.05	4.765	4.503	5.298	4.92	5.788	7.358	8.657	6.525	7.677	ns
6 mA	Slow	4.081	4.801	4.259	5.012	4.699	5.528	7.659	9.011	6.709	7.893	ns
8 mA	Slow	4.234	4.98	4.068	4.786	4.521	5.319	8.218	9.668	7.05	8.294	ns

1. Delay increases with drive strength are inherent to built-in slew control circuitry for simultaneous switching output (SSO) management.

Table 118 • DDR1/SSTL2 Class II Transmitter Characteristics for MSIO I/O Bank (Output and Tristate Buffers)

	T_{DP}		T_{ZL}		T_{ZH}		T_{HZ}		T_{LZ}		Unit
	-1	-Std	-1	-Std	-1	-Std	-1	-Std	-1	-Std	
Single-ended	2.29	2.693	1.988	2.338	1.978	2.326	1.989	2.34	1.979	2.328	ns
Differential	2.418	2.846	2.304	2.711	2.297	2.702	2.131	2.506	2.124	2.499	ns

2.3.6.4 Stub-Series Terminated Logic 1.8 V (SSTL18)

SSTL18 Class I and Class II are supported in IGLOO2 and SmartFusion2 SoC FPGAs, and also comply with the reduced and full drive double data rate (DDR2) standard. IGLOO2 and SmartFusion2 SoC FPGA I/Os support both standards for single-ended signaling and differential signaling for SSTL18. This standard requires a differential amplifier input buffer and a push-pull output buffer.

Minimum and Maximum DC/AC Input and Output Levels Specification

Table 119 • SSTL18 DC Recommended DC Operating Conditions

Parameter	Symbol	Min	Typ	Max	Unit
Supply voltage	V_{DDI}	1.71	1.8	1.89	V
Termination voltage	V_{TT}	0.838	0.900	0.964	V
Input reference voltage	V_{REF}	0.838	0.900	0.964	V

Table 120 • SSTL18 DC Input Voltage Specification

Parameter	Symbol	Min	Max	Unit
DC input logic high	V_{IH} (DC)	$V_{REF} + 0.125$	1.89	V
DC input logic low	V_{IL} (DC)	-0.3	$V_{REF} - 0.125$	V
Input current high ¹	I_{IH} (DC)			
Input current low ¹	I_{IL} (DC)			

1. See Table 24, page 22.

Table 121 • SSTL18 DC Output Voltage Specification

Parameter	Symbol	Min	Max	Unit
SSTL18 Class I (DDR2 Reduced Drive)				
DC output logic high	V_{OH}	$V_{TT} + 0.603$		V
DC output logic low	V_{OL}		$V_{TT} - 0.603$	V
Output minimum source DC current (DDRIO I/O bank only)	I_{OH} at V_{OH}	6.5		mA
Output minimum sink current (DDRIO I/O bank only)	I_{OL} at V_{OL}	-6.5		mA
SSTL18 Class II (DDR2 Full Drive)¹				
DC output logic high	V_{OH}	$V_{TT} + 0.603$		V
DC output logic low	V_{OL}		$V_{TT} - 0.603$	V
Output minimum source DC current (DDRIO I/O bank only)	I_{OH} at V_{OH}	13.4		mA
Output minimum sink current (DDRIO I/O bank only)	I_{OL} at V_{OL}	-13.4		mA

1. To meet JEDEC Electrical Compliance, use DDR2 Full Drive Transmitter.

Table 136 • SSTL15 AC Test Parameter Specifications (for DDRIO I/O Bank Only)

Parameter	Symbol	Typ	Unit
Measuring/trip point for data path	V_{TRIP}	0.75	V
Resistance for enable path (T_{ZH} , T_{ZL} , T_{HZ} , T_{LZ})	R_{ENT}	2K	Ω
Capacitive loading for enable path (T_{ZH} , T_{ZL} , T_{HZ} , T_{LZ})	C_{ENT}	5	pF
Reference resistance for data test path for SSTL15 Class I (T_{DP})	RTT_TEST	50	Ω
Reference resistance for data test path for SSTL15 Class II (T_{DP})	RTT_TEST	25	Ω
Capacitive loading for data path (T_{DP})	C_{LOAD}	5	pF

AC Switching Characteristics

Worst commercial-case conditions: $T_J = 85\text{ }^\circ\text{C}$, $V_{DD} = 1.14\text{ V}$, $V_{DDI} = 1.425\text{ V}$

Table 137 • DDR3/SSTL15 Receiver Characteristics for DDRIO I/O Bank – with Calibration Only

		T_{PY}		
On-Die Termination (ODT)		-1	-Std	Unit
Pseudo differential	None	1.605	1.888	ns
	20	1.616	1.901	ns
	30	1.613	1.897	ns
	40	1.611	1.895	ns
	60	1.609	1.893	ns
	120	1.607	1.89	ns
True differential	None	1.623	1.91	ns
	20	1.637	1.926	ns
	30	1.63	1.918	ns
	40	1.626	1.914	ns
	60	1.622	1.91	ns
	120	1.619	1.905	ns

Table 138 • DDR3/SSTL15 Transmitter Characteristics (Output and Tristate Buffers)

	T_{DP}		T_{ZL}		T_{ZH}		T_{HZ}		T_{LZ}		Unit
	-1	-Std	-1	-Std	-1	-Std	-1	-Std	-1	-Std	
DDR3 Reduced Drive/SSTL15 Class I (for DDRIO I/O Bank)											
Single-ended	2.533	2.98	2.522	2.967	2.523	2.968	2.427	2.855	2.428	2.856	ns
Differential	2.555	3.005	3.073	3.615	3.073	3.615	2.416	2.843	2.416	2.843	ns
DDR3 Full Drive/SSTL15 Class II (for DDRIO I/O Bank)											
Single-ended	2.53	2.977	2.514	2.958	2.516	2.96	2.422	2.849	2.425	2.852	ns
Differential	2.552	3.002	2.591	3.048	2.59	3.047	2.882	3.391	2.881	3.39	ns

Table 156 • LPDDR-LVCMOS 1.8 V AC Test Parameter Specifications

Parameter	Symbol	Typ	Unit
Measuring/trip point for data path	V_{TRIP}	0.9	V
Resistance for enable path (T_{ZH} , T_{ZL} , T_{HZ} , T_{LZ})	R_{ENT}	2K	Ω
Capacitive loading for enable path (T_{ZH} , T_{ZL} , T_{HZ} , T_{LZ})	C_{ENT}	5	pF
Capacitive loading for data path (T_{DP})	C_{LOAD}	5	pF

Table 157 • LPDDR-LVCMOS 1.8 V Mode Transmitter Drive Strength Specification for DDRIO Bank

Output Drive Selection	V_{OH} (V) Min	V_{OL} (V) Max	I_{OH} (at V_{OH}) mA	I_{OL} (at V_{OL}) mA
2 mA	$V_{DDI} - 0.45$	0.45	2	2
4 mA	$V_{DDI} - 0.45$	0.45	4	4
6 mA	$V_{DDI} - 0.45$	0.45	6	6
8 mA	$V_{DDI} - 0.45$	0.45	8	8
10 mA	$V_{DDI} - 0.45$	0.45	10	10
12 mA	$V_{DDI} - 0.45$	0.45	12	12
16 mA ¹	$V_{DDI} - 0.45$	0.45	16	16

1. 16 mA Drive Strengths, All Slews, meet LPDDR JEDEC electrical compliance.

Table 158 • LPDDR-LVCMOS 1.8V AC Switching Characteristics for Receiver (for DDRIO I/O Bank with Fixed Code - Input Buffers)

ODT (On Die Termination)	-1	-Std	-1	-Std	Unit
None	1.968	2.315	2.099	2.47	ns

Table 159 • LPDDR-LVCMOS 1.8 V AC Switching Characteristics for Transmitter for DDRIO I/O Bank (Output and Tristate Buffers)

Output Drive Selection	Slew Control	T_{DP}		T_{ZL}		T_{ZH}		T_{HZ} ¹		T_{LZ} ¹		Unit
		-1	-Std	-1	-Std	-1	-Std	-1	-Std	-1	-Std	
2 mA	slow	4.234	4.981	3.646	4.29	4.245	4.995	4.908	5.774	4.434	5.216	ns
	medium	3.824	4.498	3.282	3.861	3.834	4.511	4.625	5.441	4.116	4.843	ns
	medium_fast	3.627	4.267	3.111	3.66	3.637	4.279	4.481	5.272	3.984	4.687	ns
	fast	3.605	4.241	3.097	3.644	3.615	4.253	4.472	5.262	3.973	4.674	ns
4 mA	slow	3.923	4.615	3.314	3.9	3.918	4.61	5.403	6.356	4.894	5.757	ns
	medium	3.518	4.138	2.961	3.484	3.515	4.135	5.121	6.025	4.561	5.366	ns
	medium_fast	3.321	3.907	2.783	3.275	3.317	3.903	4.966	5.843	4.426	5.206	ns
	fast	3.301	3.883	2.77	3.259	3.296	3.878	4.957	5.831	4.417	5.196	ns
6 mA	slow	3.71	4.364	3.104	3.652	3.702	4.355	5.62	6.612	5.08	5.977	ns
	medium	3.333	3.921	2.779	3.27	3.325	3.913	5.346	6.289	4.777	5.62	ns
	medium_fast	3.155	3.712	2.62	3.083	3.146	3.702	5.21	6.13	4.657	5.479	ns
	fast	3.134	3.688	2.608	3.068	3.125	3.677	5.202	6.12	4.648	5.468	ns
8 mA	slow	3.619	4.258	3.007	3.538	3.607	4.244	5.815	6.841	5.249	6.175	ns

2.3.9 DDR Module Specification

This section describes input and output DDR module and timing specifications.

2.3.9.1 Input DDR Module

Figure 10 • Input DDR Module

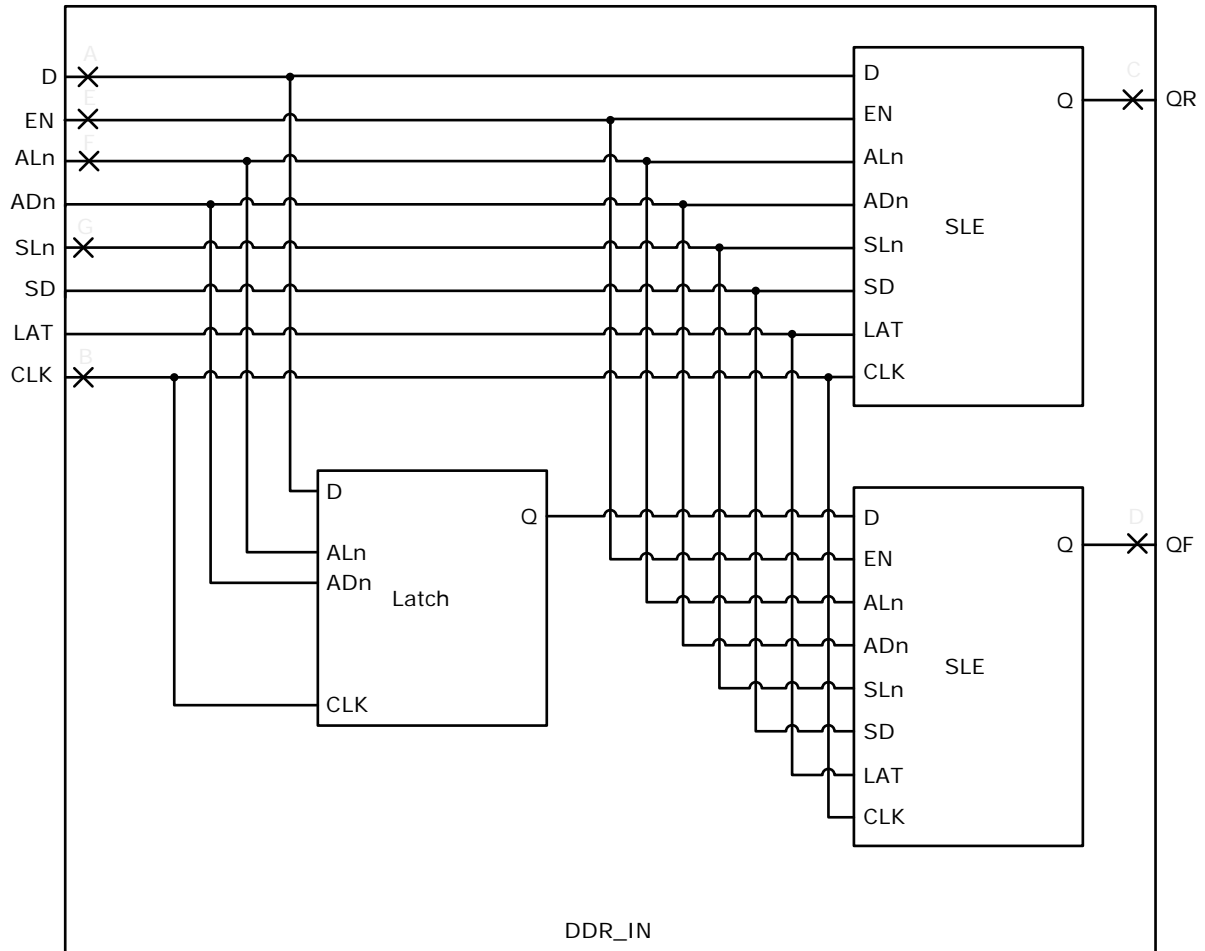

Table 233 • RAM1K18 – Dual-Port Mode for Depth x Width Configuration 4K x 4 (continued)

Parameter	Symbol	–1		–Std		Unit
		Min	Max	Min	Max	
Pipelined clock minimum pulse width low	$T_{PLCLKMPWL}$	1.125		1.323		ns
Read access time with pipeline register			0.323		0.38	ns
Read access time without pipeline register	T_{CLK2Q}		2.273		2.673	ns
Access time with feed-through write timing			1.511		1.778	ns
Address setup time	T_{ADDRSU}	0.543		0.638		ns
Address hold time	T_{ADDRHD}	0.274		0.322		ns
Data setup time	T_{DSU}	0.334		0.393		ns
Data hold time	T_{DHD}	0.082		0.096		ns
Block select setup time	T_{BLKSU}	0.207		0.244		ns
Block select hold time	T_{BLKHD}	0.216		0.254		ns
Block select to out disable time (when pipelined register is disabled)	T_{BLK2Q}		1.511		1.778	ns
Block select minimum pulse width	T_{BLKMPW}	0.186		0.219		ns
Read enable setup time	T_{RDESU}	0.516		0.607		ns
Read enable hold time	T_{RDEHD}	0.071		0.083		ns
Pipelined read enable setup time (A_DOUT_EN, B_DOUT_EN)	$T_{RDPLESU}$	0.248		0.291		ns
Pipelined read enable hold time (A_DOUT_EN, B_DOUT_EN)	$T_{RDPLEHD}$	0.102		0.12		ns
Asynchronous reset to output propagation delay	T_{R2Q}		1.507		1.773	ns
Asynchronous reset removal time	T_{RSTREM}	0.506		0.595		ns
Asynchronous reset recovery time	T_{RSTREC}	0.004		0.005		ns
Asynchronous reset minimum pulse width	T_{RSTMPW}	0.301		0.354		ns
Pipelined register asynchronous reset removal time	$T_{PLRSTREM}$	–0.279		–0.328		ns
Pipelined register asynchronous reset recovery time	$T_{PLRSTREC}$	0.327		0.385		ns
Pipelined register asynchronous reset minimum pulse width	$T_{PLRSTMPW}$	0.282		0.332		ns
Synchronous reset setup time	T_{SRSTSU}	0.226		0.265		ns
Synchronous reset hold time	T_{SRSTHD}	0.036		0.043		ns
Write enable setup time	T_{WESU}	0.458		0.539		ns
Write enable hold time	T_{WEHD}	0.048		0.057		ns
Maximum frequency	F_{MAX}		400		340	MHz

The following table lists the RAM1K18 – dual-port mode for depth × width configuration 8K × 2 in worst commercial-case conditions when $T_J = 85\text{ }^\circ\text{C}$, $V_{DD} = 1.14\text{ V}$.

Table 234 • RAM1K18 – Dual-Port Mode for Depth × Width Configuration 8K × 2

Parameter	Symbol	–1		–Std		Unit
		Min	Max	Min	Max	
Clock period	T_{CY}	2.5		2.941		ns
Clock minimum pulse width high	$T_{CLKMPWH}$	1.125		1.323		ns
Clock minimum pulse width low	$T_{CLKMPWL}$	1.125		1.323		ns
Pipelined clock period	T_{PLCY}	2.5		2.941		ns
Pipelined clock minimum pulse width high	$T_{PLCLKMPWH}$	1.125		1.323		ns
Pipelined clock minimum pulse width low	$T_{PLCLKMPWL}$	1.125		1.323		ns
Read access time with pipeline register				0.32	0.377	ns
Read access time without pipeline register	T_{CLK2Q}			2.272	2.673	ns
Access time with feed-through write timing				1.511	1.778	ns
Address setup time	T_{ADDRSU}	0.612		0.72		ns
Address hold time	T_{ADDRHD}	0.274		0.322		ns
Data setup time	T_{DSU}	0.33		0.388		ns
Data hold time	T_{DHD}	0.082		0.096		ns
Block select setup time	T_{BLKSU}	0.207		0.244		ns
Block select hold time	T_{BLKHD}	0.216		0.254		ns
Block select to out disable time (when pipelined register is disabled)	T_{BLK2Q}			1.511	1.778	ns
Block select minimum pulse width	T_{BLKMPW}	0.186		0.219		ns
Read enable setup time	T_{RDESU}	0.529		0.622		ns
Read enable hold time	T_{RDEHD}	0.071		0.083		ns
Pipelined read enable setup time (A_DOUT_EN, B_DOUT_EN)	$T_{RDPLESU}$	0.248		0.291		ns
Pipelined read enable hold time (A_DOUT_EN, B_DOUT_EN)	$T_{RDPLEHD}$	0.102		0.12		ns
Asynchronous reset to output propagation delay	T_{R2Q}			1.528	1.797	ns
Asynchronous reset removal time	T_{RSTREM}	0.506		0.595		ns
Asynchronous reset recovery time	T_{RSTREC}	0.004		0.005		ns
Asynchronous reset minimum pulse width	T_{RSTMPW}	0.301		0.354		ns
Pipelined register asynchronous reset removal time	$T_{PLRSTREM}$	–0.279		–0.328		ns
Pipelined register asynchronous reset recovery time	$T_{PLRSTREC}$	0.327		0.385		ns
Pipelined register asynchronous reset minimum pulse width	$T_{PLRSTMPW}$	0.282		0.332		ns
Synchronous reset setup time	T_{SRSTSU}	0.226		0.265		ns
Synchronous reset hold time	T_{SRSTHD}	0.036		0.043		ns
Write enable setup time	T_{WESU}	0.488		0.574		ns
Write enable hold time	T_{WEHD}	0.048		0.057		ns
Maximum frequency	F_{MAX}			400	340	MHz

Table 241 • μ SRAM (RAM256x4) in 256 x 4 Mode (continued)

Parameter	Symbol	-1		-Std		Unit
		Min	Max	Min	Max	
Write address hold time	$T_{ADDRCHD}$	0.245		0.288		ns
Write enable setup time	T_{WECSU}	0.397		0.467		ns
Write enable hold time	T_{WECHD}	-0.03		-0.03		ns
Maximum frequency	F_{MAX}		250		250	MHz

The following table lists the μ SRAM in 512 x 2 mode in worst commercial-case conditions when $T_J = 85^\circ\text{C}$, $V_{DD} = 1.14\text{ V}$.

Table 242 • μ SRAM (RAM512x2) in 512 x 2 Mode

Parameter	Symbol	-1		-Std		Unit
		Min	Max	Min	Max	
Read clock period	T_{CY}	4		4		ns
Read clock minimum pulse width high	$T_{CLKMPWH}$	1.8		1.8		ns
Read clock minimum pulse width low	$T_{CLKMPWL}$	1.8		1.8		ns
Read pipeline clock period	T_{PLCY}	4		4		ns
Read pipeline clock minimum pulse width high	$T_{PLCLKMPWH}$	1.8		1.8		ns
Read pipeline clock minimum pulse width low	$T_{PLCLKMPWL}$	1.8		1.8		ns
Read access time with pipeline register	T_{CLK2Q}		0.27		0.31	ns
Read access time without pipeline register				1.76		2.08
Read address setup time in synchronous mode	T_{ADDRSU}	0.301		0.354		ns
Read address setup time in asynchronous mode			1.96		2.306	
Read address hold time in synchronous mode	T_{ADDRHD}	0.137		0.161		ns
Read address hold time in asynchronous mode			-0.58		-0.68	
Read enable setup time	T_{RDENSU}	0.278		0.327		ns
Read enable hold time	T_{RDENHD}	0.057		0.067		ns
Read block select setup time	T_{BLKSU}	1.839		2.163		ns
Read block select hold time	T_{BLKHD}	-0.65		-0.77		ns
Read block select to out disable time (when pipelined register is disabled)	T_{BLK2Q}		2.14		2.52	ns
Read asynchronous reset removal time (pipelined clock)	T_{RSTREM}	-0.02		-0.03		ns
Read asynchronous reset removal time (non-pipelined clock)			0.046		0.054	
Read asynchronous reset recovery time (pipelined clock)	T_{RSTREC}	0.507		0.597		ns
Read asynchronous reset recovery time (non-pipelined clock)			0.236		0.278	
Read asynchronous reset to output propagation delay (with pipelined register enabled)	T_{R2Q}		0.83		0.98	ns
Read synchronous reset setup time	T_{SRSTSU}	0.271		0.319		ns
Read synchronous reset hold time	T_{SRSTHD}	0.061		0.071		ns

Table 251 • SmartFusion2 Cortex-M3 ISP Programming (eNVM Only) (continued)

M2S/M2GL Device	Image size Bytes	Authenticate	Program	Verify	Unit
150	544496	10	158	15	Sec

Table 252 • SmartFusion2 Cortex-M3 ISP Programming (Fabric and eNVM)

M2S/M2GL Device	Image size Bytes	Authenticate	Program	Verify	Unit
005	439296	9	61	11	Sec
010	842688	15	107	21	Sec
025	1497408	26	121	35	Sec
050	2695168	43	141	55	Sec
060	2686464	48	143	60	Sec
090	4190208	75	244	91	Sec
150	6682768	117	296	141	Sec

Table 253 • Programming Times with 100 kHz, 25 MHz, and 12.5 MHz SPI Clock Rates (Fabric Only)

M2S/M2GL Device	Auto Programming	Auto Update	Programming Recovery	Unit
	100 kHz	25 MHz	12.5 MHz	
005	47	27	28	Sec
010	77	35	35	Sec
025	150	42	41	Sec
050	33 ¹	Not Supported	Not Supported	Sec
060	291	83	82	Sec
090	427	109	108	Sec
150	708	157	160	Sec

1. Auto Programming in 050 device is done through SC_SPI, and SPI CLK is set to 6.25 MHz.

Table 254 • Programming Times with 100 kHz, 25 MHz, and 12.5 MHz SPI Clock Rates (eNVM Only)

M2S/M2GL Device	Auto Programming	Auto Update	Programming Recovery	Unit
	100 kHz	25 MHz	12.5 MHz	
005	41	48	49	Sec
010	86	87	87	Sec
025	87	85	86	Sec
050	85	Not Supported	Not Supported	Sec
060	78	86	86	Sec
090	154	162	162	Sec

The following table lists the programming times in worst-case conditions when $T_J = 100\text{ }^\circ\text{C}$, $V_{DD} = 1.14\text{ V}$. External SPI flash part# AT25DF641-s3H is used during this measurement.

Table 256 • JTAG Programming (Fabric Only)

M2S/M2GL Device	Image size		Program	Verify	Unit
	Bytes				
005	302672		44	10	Sec
010	568784		50	18	Sec
025	1223504		73	26	Sec
050	2424832		88	54	Sec
060	2418896		99	54	Sec
090	3645968		135	126	Sec
150	6139184		177	193	Sec

Table 257 • JTAG Programming (eNVM Only)

M2S/M2GL Device	Image size		Program	Verify	Unit
	Bytes				
005	137536		61	4	Sec
010	274816		100	9	Sec
025	274816		100	9	Sec
050	2,78,528		106	8	Sec
060	268480		98	8	Sec
090	544496		176	15	Sec
150	544496		177	15	Sec

Table 258 • JTAG Programming (Fabric and eNVM)

M2S/M2GL Device	Image size		Program	Verify	Unit
	Bytes				
005	439296		71	11	Sec
010	842688		129	20	Sec
025	1497408		142	35	Sec
050	2695168		184	59	Sec
060	2686464		180	70	Sec
090	4190208		288	147	Sec
150	6682768		338	231	Sec

2.3.14 Math Block Timing Characteristics

The fundamental building block in any digital signal processing algorithm is the multiply-accumulate function. Each IGLOO2 and SmartFusion2 SoC math block supports 18×18 signed multiplication, dot product, and built-in addition, subtraction, and accumulation units to combine multiplication results efficiently. The following table lists the math blocks with all registers used in worst commercial-case conditions when $T_J = 85\text{ }^\circ\text{C}$, $V_{DD} = 1.14\text{ V}$.

Table 268 • Math Blocks with all Registers Used

Parameter	Symbol	-1		-Std		Unit
		Min	Max	Min	Max	
Input, control register setup time	T_{MISU}	0.149		0.176		ns
Input, control register hold time	T_{MIHD}	1.68		1.976		ns
CDIN input setup time	$T_{MOCDINSU}$	0.185		0.218		ns
CDIN input hold time	$T_{MOCDINHHD}$	0.08		0.094		ns
Synchronous reset/enable setup time	$T_{MSRSTENSU}$	-0.419		-0.493		ns
Synchronous reset/enable hold time	$T_{MSRSTENHD}$	0.011		0.013		ns
Asynchronous reset removal time	$T_{MARSTREM}$	0		0		ns
Asynchronous reset recovery time	$T_{MARSTREC}$	0.088		0.104		ns
Output register clock to out delay	T_{MOCQ}		0.232		0.273	ns
CLK minimum period	T_{MCLKMP}	2.245		2.641		ns

The following table lists the math blocks with input bypassed and output registers used in worst commercial-case conditions when $T_J = 85\text{ }^\circ\text{C}$, $V_{DD} = 1.14\text{ V}$.

Table 269 • Math Block with Input Bypassed and Output Registers Used

Parameter	Symbol	-1		-Std		Unit
		Min	Max	Min	Max	
Output register setup time	T_{MOSU}	2.294		2.699		ns
Output register hold time	T_{MOHD}	1.68		1.976		ns
CDIN input setup time	$T_{MOCDINSU}$	0.115		0.136		ns
CDIN input hold time	$T_{MOCDINHHD}$	-0.444		-0.522		ns
Synchronous reset/enable setup time	$T_{MSRSTENSU}$	-0.419		-0.493		ns
Synchronous reset/enable hold time	$T_{MSRSTENHD}$	0.011		0.013		ns
Asynchronous reset removal time	$T_{MARSTREM}$	0		0		ns
Asynchronous reset recovery time	$T_{MARSTREC}$	0.014		0.017		ns
Output register clock to out delay	T_{MOCQ}		0.232		0.273	ns
CLK minimum period	T_{MCLKMP}	2.179		2.563		ns

Table 277 • Electrical Characteristics of the Crystal Oscillator – High Gain Mode (20 MHz) (continued)

Parameter	Symbol	Min	Typ	Max	Unit	Condition
Startup time (with regard to stable oscillator output)	SUXTAL			0.8	ms	005, 010, 025, and 050 devices
				1.0	ms	090 and 150 devices

Table 278 • Electrical Characteristics of the Crystal Oscillator – Medium Gain Mode (2 MHz)

Parameter	Symbol	Min	Typ	Max	Unit	Condition
Operating frequency	FXTAL		2		MHz	
Accuracy	ACCXTAL			0.00105	%	050 devices
				0.003	%	005, 010, 025, 090, and 150 devices
				0.004	%	060 devices
Output duty cycle	CYCXTAL		49–51	47–53	%	
Output period jitter (peak to peak)	JITPERXTAL		1	5	ns	
Output cycle to cycle jitter (peak to peak)	JITCYCXTAL		1	5	ns	
Operating current	IDYNXTAL		0.3		mA	
Input logic level high	VIHXTAL	0.9 V _{PP}			V	
Input logic level low	VILXTAL			0.1 V _{PP}	V	
Startup time (with regard to stable oscillator output)	SUXTAL			4.5	ms	010 and 050 devices
				5	ms	005 and 025 devices
				7	ms	090 and 150 devices

Table 279 • Electrical Characteristics of the Crystal Oscillator – Low Gain Mode (32 kHz)

Parameter	Symbol	Min	Typ	Max	Unit	Condition
Operating frequency	FXTAL		32		kHz	
Accuracy	ACCXTAL			0.004	%	005, 010, 025, 050, 060, and 090 devices
				0.005	%	150 devices
Output duty cycle	CYCXTAL		49–51	47–53	%	
Output period jitter (peak to peak)	JITPERXTAL		150	300	ns	
Output cycle to cycle jitter (peak to peak)	JITCYCXTAL		150	300	ns	
Operating current	IDYNXTAL		0.044		mA	010 and 050 devices
			0.060		mA	005, 025, 060, 090, and 150 devices
Input logic level high	VIHXTAL	0.9 V _{PP}			V	
Input logic level low	VILXTAL			0.1 V _{PP}	V	
Startup time (with regard to stable oscillator output)	SUXTAL			115	ms	005, 025, 050, 090, and 150 devices
				126	ms	010 devices

1. The minimum output clock frequency is limited by the PLL. For more information, see *UG0449: SmartFusion2 and IGLOO2 Clocking Resources User Guide*.
2. The PLL is used in conjunction with the Clock Conditioning Circuitry. Performance is limited by the CCC output frequency.

The following table lists the CCC/PLL jitter specifications in worst-case industrial conditions when $T_J = 100\text{ }^\circ\text{C}$, $V_{DD} = 1.14\text{ V}$.

Table 283 • IGLOO2 and SmartFusion2 SoC FPGAs CCC/PLL Jitter Specifications

CCC Output Maximum Peak-to-Peak Period Jitter F_{OUT_CCC}						
Parameter	Conditions/Package Combinations				Unit	
10 FG484, 050 FG896/FG484/FCS325 Packages¹	SSO = 0	0 < SSO <= 2	SSO <= 4	SSO <= 8	SSO <= 16	
20 MHz to 100 MHz	Max(110, ± 1% x (1/ F_{OUT_CCC}))	Max(150, ± 1% x (1/ F_{OUT_CCC}))				ps
100 MHz to 400 MHz	Max(120, ± 1% x (1/ F_{OUT_CCC}))	Max(150, ± 1% x (1/ F_{OUT_CCC}))		Max(170, ± 1% x (1/ F_{OUT_CCC}))		ps
025 FG484/FCS325 Package¹	0 < SSO <=16					
20 MHz to 74 MHz	± 1% x (1/ F_{OUT_CCC})					ps
74 MHz to 400 MHz	210					ps
005 FG484 Package¹	0 < SSO <=16					
20 MHz to 53 MHz	± 1% x (1/ F_{OUT_CCC})					ps
53 MHz to 400 MHz	270					ps
090 FG676 and FC325 Package¹	0 < SSO <=16					
20 MHz to 100 MHz	± 1% x (1/ F_{OUT_CCC})					ps
100 MHz to 400 MHz	150					ps
060 FG676 Package¹	0 < SSO <=16					
20 MHz to 100 MHz	± 1% x (1/ F_{OUT_CCC})					ps
100 MHz to 400 MHz	150					ps
150 FC1152 Package¹	0 < SSO <=16					
20 MHz to 100 MHz	± 1% x (1/ F_{OUT_CCC})					ps
100 MHz to 400 MHz	120					ps

1. SSO data is based on LVCMOS 2.5 V MSIO and/or MSIOD bank I/Os.

2.3.22 JTAG

Table 284 • JTAG 1532 for 005, 010, 025, and 050 Devices

Parameter	Symbol	005		010		025		050		Unit
		-1	-Std	-1	-Std	-1	-Std	-1	-Std	
Clock to Q (data out)	T_{TCK2Q}	7.47	8.79	7.73	9.09	7.75	9.12	7.89	9.28	ns
Reset to Q (data out)	T_{RSTB2Q}	7.65	9	6.43	7.56	6.13	7.21	7.40	8.70	ns
Test data input setup time	T_{DISU}	-1.05	-0.89	-0.69	-0.59	-0.67	-0.57	-0.30	-0.25	ns
Test data input hold time	T_{DIHD}	2.38	2.8	2.38	2.8	2.42	2.85	2.09	2.45	ns
Test mode select setup time	T_{TMSSU}	-0.73	-0.62	-1.03	-1.21	-1.1	-0.94	0.28	0.33	ns
Test mode select hold time	T_{TMDHD}	1.36	1.6	1.43	1.68	1.93	2.27	0.16	0.19	ns
ResetB removal time	$T_{TRSTREM}$	-0.77	-0.65	-1.08	-0.92	-1.33	-1.13	-0.45	-0.38	ns
ResetB recovery time	$T_{TRSTREC}$	-0.76	-0.65	-1.07	-0.91	-1.34	-1.14	-0.45	-0.38	ns
TCK maximum frequency	F_{TCKMAX}	25	21.25	25	21.25	25	21.25	25.00	21.25	MHz

Table 285 • JTAG 1532 for 060, 090, and 150 Devices

Parameter	Symbol	060		090		150		Unit
		-1	-Std	-1	-Std	-1	-Std	
Clock to Q (data out)	T_{TCK2Q}	8.38	9.86	8.96	10.54	8.66	10.19	ns
Reset to Q (data out)	T_{RSTB2Q}	8.54	10.04	7.75	9.12	8.79	10.34	ns
Test data input setup time	T_{DISU}	-1.18	-1	-1.31	-1.11	-0.96	-0.82	ns
Test data input hold time	T_{DIHD}	2.52	2.97	2.68	3.15	2.57	3.02	ns
Test mode select setup time	T_{TMSSU}	-0.97	-0.83	-1.02	-0.87	-0.53	-0.45	ns
Test mode select hold time	T_{TMDHD}	1.7	2	1.67	1.96	1.02	1.2	ns
ResetB removal time	$T_{TRSTREM}$	-1.21	-1.03	-0.76	-0.65	-1.03	-0.88	ns
ResetB recovery time	$T_{TRSTREC}$	-1.21	-1.03	-0.77	-0.65	-1.03	-0.88	ns
TCK maximum frequency	F_{TCKMAX}	25	21.25	25	21.25	25	21.25	MHz

2.3.23 System Controller SPI Characteristics