



Welcome to [E-XFL.COM](https://www.e-xfl.com)

### **Embedded - System On Chip (SoC): The Heart of Modern Embedded Systems**

**Embedded - System On Chip (SoC)** refers to an integrated circuit that consolidates all the essential components of a computer system into a single chip. This includes a microprocessor, memory, and other peripherals, all packed into one compact and efficient package. SoCs are designed to provide a complete computing solution, optimizing both space and power consumption, making them ideal for a wide range of embedded applications.

### **What are Embedded - System On Chip (SoC)?**

**System On Chip (SoC)** integrates multiple functions of a computer or electronic system onto a single chip. Unlike traditional multi-chip solutions, SoCs combine a central

#### **Details**

Product Status	Active
Architecture	MCU, FPGA
Core Processor	ARM® Cortex®-M3
Flash Size	512KB
RAM Size	64KB
Peripherals	DDR, PCIe, SERDES
Connectivity	CANbus, Ethernet, I <sup>2</sup> C, SPI, UART/USART, USB
Speed	166MHz
Primary Attributes	FPGA - 90K Logic Modules
Operating Temperature	0°C ~ 85°C (TJ)
Package / Case	484-BGA
Supplier Device Package	484-FPBGA (23x23)
Purchase URL	<a href="https://www.e-xfl.com/product-detail/microchip-technology/m2s090-1fgg484">https://www.e-xfl.com/product-detail/microchip-technology/m2s090-1fgg484</a>

Table 214	LVPECL Recommended DC Operating Conditions	64
Table 215	LVPECL Receiver Characteristics for MSIO I/O Bank	65
Table 216	LVPECL DC Input Voltage Specification	65
Table 217	LVPECL DC Differential Voltage Specification	65
Table 218	LVPECL Minimum and Maximum AC Switching Speeds	65
Table 219	Input Data Register Propagation Delays	67
Table 220	Output/Enable Data Register Propagation Delays	69
Table 221	Input DDR Propagation Delays	71
Table 222	Output DDR Propagation Delays	74
Table 223	Combinatorial Cell Propagation Delays	76
Table 224	Register Delays	77
Table 225	150 Device Global Resource	78
Table 226	090 Device Global Resource	78
Table 227	050 Device Global Resource	78
Table 228	025 Device Global Resource	78
Table 229	010 Device Global Resource	79
Table 230	005 Device Global Resource	79
Table 231	RAM1K18 – Dual-Port Mode for Depth × Width Configuration 1K × 18	79
Table 232	RAM1K18 – Dual-Port Mode for Depth × Width Configuration 2K × 9	80
Table 233	RAM1K18 – Dual-Port Mode for Depth × Width Configuration 4K × 4	81
Table 234	RAM1K18 – Dual-Port Mode for Depth × Width Configuration 8K × 2	83
Table 235	RAM1K18 – Dual-Port Mode for Depth × Width Configuration 16K × 1	84
Table 236	RAM1K18 – Two-Port Mode for Depth × Width Configuration 512 × 36	85
Table 237	μSRAM (RAM64x18) in 64 × 18 Mode	86
Table 238	μSRAM (RAM64x16) in 64 × 16 Mode	87
Table 239	μSRAM (RAM128x9) in 128 × 9 Mode	88
Table 240	μSRAM (RAM128x8) in 128 × 8 Mode	89
Table 241	μSRAM (RAM256x4) in 256 × 4 Mode	91
Table 242	μSRAM (RAM512x2) in 512 × 2 Mode	92
Table 243	μSRAM (RAM1024x1) in 1024 × 1 Mode	93
Table 244	JTAG Programming (Fabric Only)	94
Table 245	JTAG Programming (eNVM Only)	95
Table 246	JTAG Programming (Fabric and eNVM)	95
Table 247	2 Step IAP Programming (Fabric Only)	95
Table 248	2 Step IAP Programming (eNVM Only)	96
Table 249	2 Step IAP Programming (Fabric and eNVM)	96
Table 250	SmartFusion2 Cortex-M3 ISP Programming (Fabric Only)	96
Table 251	SmartFusion2 Cortex-M3 ISP Programming (eNVM Only)	96
Table 252	SmartFusion2 Cortex-M3 ISP Programming (Fabric and eNVM)	97
Table 253	Programming Times with 100 kHz, 25 MHz, and 12.5 MHz SPI Clock Rates (Fabric Only)	97
Table 254	Programming Times with 100 kHz, 25 MHz, and 12.5 MHz SPI Clock Rates (eNVM Only)	97
Table 255	Programming Times with 100 kHz, 25 MHz, and 12.5 MHz SPI Clock Rates (Fabric and eNVM)	98
Table 256	JTAG Programming (Fabric Only)	99
Table 257	JTAG Programming (eNVM Only)	99
Table 258	JTAG Programming (Fabric and eNVM)	99
Table 259	2 Step IAP Programming (Fabric Only)	100
Table 260	2 Step IAP Programming (eNVM Only)	100
Table 261	2 Step IAP Programming (Fabric and eNVM)	100
Table 262	SmartFusion2 Cortex-M3 ISP Programming (Fabric Only)	101
Table 263	SmartFusion2 Cortex-M3 ISP Programming (eNVM Only)	101
Table 264	SmartFusion2 Cortex-M3 ISP Programming (Fabric and eNVM)	101
Table 265	Programming Times with 100 kHz, 25 MHz, and 12.5 MHz SPI Clock Rates (Fabric Only)	102
Table 266	Programming Times with 100 kHz, 25 MHz, and 12.5 MHz SPI Clock Rates (eNVM Only)	102
Table 267	Programming Times with 100 kHz, 25 MHz, and 12.5 MHz SPI Clock Rates (Fabric and eNVM)	102
Table 268	Math Blocks with all Registers Used	103
Table 269	Math Block with Input Bypassed and Output Registers Used	103
Table 270	Math Block with Input Register Used and Output in Bypass Mode	104
Table 271	Math Block with Input and Output in Bypass Mode	104
Table 272	eNVM Read Performance	104

## 1.9 Revision 3.0

In revision 3.0 of this document, the Theta B/C columns and FCS325 package was updated. For more information, see Table 9, page 10 (SAR 62002).

## 1.10 Revision 2.0

The following is a summary of the changes in revision 2.0 of this document.

- Table 1, page 4 was updated (SAR 59056).
- Table 7, page 8 temperature and data retention information was updated SAR (61363).
- Storage Operating Table was updated and split into three tables – Table 5, page 7, Table 7, page 8 (SAR 58725).
- Updated Theta B/C columns and FCS325 package in Table 9, page 10 (SAR 62002).
- Added 090-FCS325 thermal resistance to Table 9, page 10 (SAR 59384).
- TQ144 package was added to Table 9, page 10 (SAR 57708).
- Added PLL jitter data for the VF400 package (SAR 53162).
- Added Additional Worst Case IDD to Table 11, page 12 and Table 12, page 13 (SAR 59077).
- Table 13, page 13, Table 14, page 13, and Table 15, page 14 were added to verify Inrush currents (SAR 56348).
- Table 18, page 19 and Table 21, page 20 – I/O speeds were replaced.
- Max speed was changed in Table 41, page 26 (SAR 57221) and in Table 52, page 29 (SAR 57113).
- Minimum and Maximum DC/AC Input and Output Levels Specification, page 29 and Table 49, page 29–Table 57, page 31 were added.
- Added Cload to Table 89, page 39 (SAR 56238).
- Removed "Rs" information in DDR Timing Measurement Table 123, page 47, Table 133, page 49, and Table 144, page 52.
- Updated drive programming for M/B-LVDS outputs (SAR 58154).
- Added an inverter bubble to DDR\_IN latch in Figure 10, page 70 (SAR 61418).
- QF waveform in Figure 11, page 71 was updated (SAR 59816).
- uSRAM Write Clock minimum values were updated in Table 237, page 86–Table 243, page 93 (SAR 55236).
- Fixed typo in the 32 kHz Crystal (XTAL) oscillator accuracy data section (SAR 59669).
- The "On-Chip Oscillator" section was split, and the Embedded NVM (eNVM) Characteristics, page 104 was added. Table 277, page 107–Table 281, page 109 were revised.(SARs 57898 and 59669).
- PLL VCP Frequency and conditions were added to Table 282, page 110 (SAR 57416).
- Fixed typo for PLL jitter data in the 100-400 MHz range (SAR 60727).
- Updated FCCC information in Table 282, page 110 and Table 283, page 111 (SAR 60799).
- Device 025 specifications were added to Table 283, page 111 (SAR 51625).
- JTAG Table 284, page 112 was replaced (SAR 51188).
- Flash\*Freeze Table 293, page 119 was replaced (SAR 57828).
- Added support for HCSL I/O Standard for SERDES reference clocks in Table 300, page 123 and Table 301, page 123 (SAR 50748).
- Tir and Tif parameters were added to Table 303, page 124 (SAR 52203).
- Speed grade consistency was fixed in tables throughout the datasheet (SAR 50722).
- Added jitter attenuation information (SAR 59405).

## 1.11 Revision 1.0

The following is a summary of the changes in revision 1.0 of this document.

- The IGLOO2 v2 and the SmartFusion2 v5 datasheets are combined into this single product family datasheet.

## 2.3.2 Power Consumption

The following sections describe the power consumptions of the devices.

### 2.3.2.1 Quiescent Supply Current

**Table 10 • Quiescent Supply Current Characteristics**

Power Supplies/Blocks	Modes and Configurations	
	Non-Flash*Freeze	Flash*Freeze
FPGA Core	On	Off
V <sub>DD</sub> /SERDES_[01]_VDD <sup>1</sup>	On	On
V <sub>PP</sub> /V <sub>PPNVM</sub>	On	On
HPMS_MDDR_PLL_VDDA/FDDR_PLL_VDDA/ CCC_XX[01]_PLL_VDDA/PLL0_PLL1_HPMS_MDDR_VDD A	0 V	0 V
SERDES_[01]_PLL_VDDA <sup>2</sup>	0 V	0 V
SERDES_[01]_L[0123]_VDDAPLL/VDD_2V5 <sup>2</sup>	On	On
SERDES_[01]_L[0123]_VDDAIIO <sup>2</sup>	On	On
V <sub>DDIx</sub> <sup>3, 4</sup>	On	On
V <sub>REFx</sub>	On	On
MSSDDR CLK	32 kHz	32 kHz
RAM	On	Sleep state
System controller	50 MHz	50 MHz
50 MHz oscillator (enable/disable)	Enable	Disabled
1 MHz oscillator (enable/disable)	Disabled	Disabled
Crystal oscillator (enable/disable)	Disabled	Disabled

1. SERDES\_[01]\_VDD Power Supply is shorted to V<sub>DD</sub>.
2. SerDes and DDR blocks to be unused.
3. V<sub>DDIx</sub> has been set to ON for test conditions as described. Banks on the east side should always be powered with the appropriate V<sub>DDI</sub> bank supplies. For details on bank power supplies, see "Recommendation for Unused Bank Supplies" table in the AC393: *SmartFusion2 and IGLOO2 Board Design Guidelines Application Note*.
4. No Differential (that is to say, LVDS) I/Os or ODT attributes to be used.

**Table 11 • SmartFusion2 and IGLOO2 Quiescent Supply Current (V<sub>DD</sub> = 1.2 V) – Typical Process**

Symbol	Modes	005	010	025	050	060	090	150	Unit	Conditions
IDC1	Non-Flash*Freeze	6.2	6.9	8.9	13.1	15.3	15.4	27.5	mA	Typical (T <sub>J</sub> = 25 °C)
		24.0	28.4	40.6	67.8	80.6	81.4	144.7	mA	Commercial (T <sub>J</sub> = 85 °C)
		35.2	41.9	60.5	102.1	121.4	122.6	219.1	mA	Industrial (T <sub>J</sub> = 100 °C)

### 2.3.5.7 2.5 V LVCMOS

LVCMOS 2.5 V is a general standard for 2.5 V applications and is supported in IGLOO2 FPGA and SmartFusion2 SoC FPGAs that are in compliance with the JEDEC specification JESD8-5A.

#### Minimum and Maximum DC/AC Input and Output Levels Specification

**Table 38 • LVCMOS 2.5 V DC Recommended DC Operating Conditions**

Parameter	Symbol	Min	Typ	Max	Unit
Supply voltage	$V_{DDI}$	2.375	2.5	2.625	V

**Table 39 • LVCMOS 2.5 V DC Input Voltage Specification**

Parameter	Symbol	Min	Max	Unit
DC input logic high (for MSIOD and DDRIO I/O banks)	$V_{IH}$ (DC)	1.7	2.625	V
DC input logic high (for MSIO I/O bank)	$V_{IH}$ (DC)	1.7	3.45	V
DC input logic low	$V_{IL}$ (DC)	-0.3	0.7	V
Input current high <sup>1</sup>	$I_{IH}$ (DC)			
Input current low <sup>1</sup>	$I_{IL}$ (DC)			

1. See Table 24, page 22.

**Table 40 • LVCMOS 2.5 V DC Output Voltage Specification**

Parameter	Symbol	Min	Max	Unit
DC output logic high	$V_{OH}$ <sup>1</sup>	$V_{DDI} - 0.4$	-	V
DC output logic low	$V_{OL}$ <sup>2</sup>		0.4	V

1. The VOH/VOL test points selected ensure compliance with LVCMOS 2.5 V JEDEC8-5A requirements.

**Table 41 • LVCMOS 2.5 V AC Minimum and Maximum Switching Speed**

Parameter	Symbol	Max	Unit	Conditions
Maximum data rate (for DDRIO I/O bank)	$D_{MAX}$	400	Mbps	AC loading: 17 pF load, maximum drive/slew
Maximum data rate (for MSIO I/O bank)	$D_{MAX}$	410	Mbps	AC loading: 17 pF load, maximum drive/slew
Maximum data rate (for MSIOD I/O bank)	$D_{MAX}$	420	Mbps	AC loading: 17 pF load, maximum drive/slew

**Table 42 • LVCMOS 2.5 V AC Calibrated Impedance Option**

Parameter	Symbol	Typ	Unit
Supported output driver calibrated impedance (for DDRIO I/O bank)	Rodt_cal	75, 60, 50, 33, 25, 20	$\Omega$

**Table 70 • LVCMOS 1.5 V Transmitter Characteristics for DDRIO I/O Bank (Output and Tristate Buffers)**  
(continued)

Output Drive Selection	Slew Control	T <sub>DP</sub>		T <sub>ZL</sub>		T <sub>ZH</sub>		T <sub>HZ</sub> <sup>1</sup>		T <sub>LZ</sub> <sup>1</sup>		Unit
		-1	-Std	-1	-Std	-1	-Std	-1	-Std	-1	-Std	
6 mA	Slow	4.244	4.993	3.465	4.076	4.233	4.979	6.39	7.518	5.736	6.748	ns
	Medium	3.774	4.44	3.05	3.587	3.762	4.426	6.114	7.193	5.397	6.35	ns
	Medium fast	3.544	4.17	2.839	3.339	3.529	4.152	5.978	7.033	5.27	6.2	ns
	Fast	3.519	4.14	2.82	3.317	3.504	4.122	5.965	7.017	5.259	6.187	ns
8 mA	Slow	4.099	4.823	3.311	3.894	4.087	4.807	6.584	7.746	5.854	6.888	ns
	Medium	3.656	4.301	2.927	3.443	3.642	4.284	6.311	7.425	5.553	6.533	ns
	Medium fast	3.437	4.044	2.731	3.213	3.42	4.023	6.182	7.273	5.435	6.394	ns
	Fast	3.41	4.012	2.715	3.193	3.393	3.991	6.178	7.269	5.425	6.383	ns
10 mA	Slow	4.029	4.74	3.238	3.809	4.015	4.723	6.732	7.921	5.965	7.018	ns
	Medium	3.601	4.237	2.867	3.372	3.586	4.218	6.473	7.615	5.669	6.669	ns
	Medium fast	3.384	3.981	2.672	3.143	3.365	3.958	6.351	7.471	5.55	6.529	ns
	Fast	3.357	3.949	2.655	3.123	3.338	3.927	6.345	7.464	5.54	6.518	ns
12 mA	Slow	3.974	4.675	3.196	3.759	3.958	4.656	6.842	8.049	6.068	7.139	ns
	Medium	3.55	4.176	2.827	3.326	3.534	4.157	6.584	7.746	5.751	6.766	ns
	Medium fast	3.345	3.935	2.638	3.103	3.325	3.911	6.488	7.633	5.641	6.637	ns
	Fast	3.316	3.902	2.621	3.083	3.297	3.878	6.486	7.63	5.626	6.619	ns

1. Delay increases with drive strength are inherent to built-in slew control circuitry for simultaneous switching output (SSO) management.

**Table 71 • LVCMOS 1.5 V Transmitter Characteristics for MSIO I/O Bank (Output and Tristate Buffers)**

Output Drive Selection	Slew Control	T <sub>DP</sub>		T <sub>ZL</sub>		T <sub>ZH</sub>		T <sub>HZ</sub> <sup>1</sup>		T <sub>LZ</sub> <sup>1</sup>		Unit
		-1	-Std	-1	-Std	-1	-Std	-1	-Std	-1	-Std	
2 mA	Slow	4.423	5.203	5.397	6.35	5.686	6.69	5.609	6.599	5.561	6.542	ns
4 mA	Slow	4.05	4.765	4.503	5.298	4.92	5.788	7.358	8.657	6.525	7.677	ns
6 mA	Slow	4.081	4.801	4.259	5.012	4.699	5.528	7.659	9.011	6.709	7.893	ns
8 mA	Slow	4.234	4.98	4.068	4.786	4.521	5.319	8.218	9.668	7.05	8.294	ns

1. Delay increases with drive strength are inherent to built-in slew control circuitry for simultaneous switching output (SSO) management.

**Table 72 • LVCMOS 1.5 V Transmitter Characteristics for MSIOD I/O Bank (Output and Tristate Buffers)**

Output Drive Selection	Slew Control	$T_{DP}$		$T_{ZL}$		$T_{ZH}$		$T_{HZ}^1$		$T_{LZ}^1$		Unit
		-1	-Std	-1	-Std	-1	-Std	-1	-Std	-1	-Std	
2 mA	Slow	2.735	3.218	3.371	3.966	3.618	4.257	6.03	7.095	5.705	6.712	ns
4 mA	Slow	2.426	2.854	2.992	3.521	3.221	3.79	6.738	7.927	6.298	7.41	ns
6 mA	Slow	2.433	2.862	2.81	3.306	3.031	3.566	7.123	8.38	6.596	7.76	ns

1. Delay increases with drive strength are inherent to built-in slew control circuitry for simultaneous switching output (SSO) management.

### 2.3.5.10 1.2 V LVCMOS

LVCMOS 1.2 is a general standard for 1.2 V applications and is supported in IGLOO2 FPGAs and SmartFusion2 SoC FPGAs in compliance to the JEDEC specification JESD8-12A.

#### Minimum and Maximum DC/AC Input and Output Levels Specification

**Table 73 • LVCMOS 1.2 V DC Recommended DC Operating Conditions**

Parameter	Symbol	Min	Typ	Max	Unit
Supply voltage	$V_{DDI}$	1.140	1.2	1.26	V

**Table 74 • LVCMOS 1.2 V DC Input Voltage Specification**

Parameter	Symbol	Min	Max	Unit
DC input logic high (for MSIOD and DDRIO I/O banks)	$V_{IH} (DC)$	$0.65 \times V_{DDI}$	1.26	V
DC input logic high (for MSIO I/O bank)	$V_{IH} (DC)$	$0.65 \times V_{DDI}$	3.45	V
DC input logic low	$V_{IL} (DC)$	-0.3	$0.35 \times V_{DDI}$	V
Input current high <sup>1</sup>	$I_{IH} (DC)$			
Input current low <sup>1</sup>	$I_{IL} (DC)$			

1. See Table 24, page 22.

**Table 75 • LVCMOS 1.2 V DC Output Voltage Specification**

Parameter	Symbol	Min	Max	Unit
DC output logic high	$V_{OH}$	$V_{DDI} \times 0.75$		V
DC output logic low	$V_{OL}$		$V_{DDI} \times 0.25$	V

**Table 76 • LVCMOS 1.2 V Minimum and Maximum AC Switching Speed**

Parameter	Symbol	Max	Unit	Conditions
Maximum data rate (for DDRIO I/O bank)	$D_{MAX}$	200	Mbps	AC loading: 17 pF load, maximum drive/slew
Maximum data rate (for MSIO I/O bank)	$D_{MAX}$	120	Mbps	AC loading: 17 pF load, maximum drive/slew
Maximum data rate (for MSIOD I/O bank)	$D_{MAX}$	160	Mbps	AC loading: 17 pF load, maximum drive/slew

**Table 131 • SSTL15 DC Output Voltage Specification (for DDRIO I/O Bank Only)**

Parameter	Symbol	Min	Max	Unit
<b>DDR3/SSTL15 Class I (DDR3 Reduced Drive)</b>				
DC output logic high	$V_{OH}$	$0.8 \times V_{DDI}$		V
DC output logic low	$V_{OL}$		$0.2 \times V_{DDI}$	V
Output minimum source DC current	$I_{OH}$ at $V_{OH}$	6.5		mA
Output minimum sink current	$I_{OL}$ at $V_{OL}$	-6.5		mA
<b>DDR3/SSTL15 Class II (DDR3 Full Drive)</b>				
DC output logic high	$V_{OH}$	$0.8 \times V_{DDI}$		V
DC output logic low	$V_{OL}$		$0.2 \times V_{DDI}$	V
Output minimum source DC current	$I_{OH}$ at $V_{OH}$	7.6		mA
Output minimum sink current	$I_{OL}$ at $V_{OL}$	-7.6		mA

**Table 132 • SSTL15 DC Differential Voltage Specification (for DDRIO I/O Bank Only)**

Parameter	Symbol	Min	Unit
DC input differential voltage	$V_{ID}$	0.2	V

**Note:** To meet JEDEC electrical compliance, use DDR3 full drive transmitter.

**Table 133 • SSTL15 AC SSTL15 Minimum and Maximum AC Switching Speed (for DDRIO I/O Bank Only)**

Parameter	Symbol	Min	Max	Unit
AC input differential voltage	$V_{DIFF}$ (AC)	0.3		V
AC differential cross point voltage	$V_x$ (AC)	$0.5 \times V_{DDI} - 0.150$	$0.5 \times V_{DDI} + 0.150$	V

**Table 134 • SSTL15 Minimum and Maximum AC Switching Speed (for DDRIO I/O Bank Only)**

Parameter	Symbol	Max	Unit	Conditions
Maximum data rate	$D_{MAX}$	667	Mbps	AC loading: per JEDEC specifications

**Table 135 • SSTL15 AC Calibrated Impedance Option (for DDRIO I/O Bank Only)**

Parameter	Symbol	Typ	Unit	Conditions
Supported output driver calibrated impedance	$R_{REF}$	34, 40	$\Omega$	Reference resistor = 240 $\Omega$
Effective impedance value (ODT)	$R_{TT}$	20, 30, 40, 60, 120	$\Omega$	Reference resistor = 240 $\Omega$



**Table 159 • LPDDR-LVCMOS 1.8 V AC Switching Characteristics for Transmitter for DDRIO I/O Bank (Output and Tristate Buffers) (continued)**

	medium	3.246	3.819	2.686	3.16	3.236	3.807	5.542	6.52	4.936	5.807	ns
	medium_fast	3.066	3.607	2.525	2.971	3.054	3.593	5.405	6.359	4.811	5.66	ns
	fast	3.046	3.584	2.513	2.957	3.034	3.57	5.401	6.353	4.803	5.651	ns
10 mA	slow	3.498	4.115	2.878	3.386	3.481	4.096	6.046	7.113	5.444	6.404	ns
	medium	3.138	3.692	2.569	3.023	3.126	3.678	5.782	6.803	5.129	6.034	ns
	medium_fast	2.966	3.489	2.414	2.841	2.951	3.472	5.666	6.665	5.013	5.897	ns
	fast	2.945	3.464	2.401	2.826	2.93	3.448	5.659	6.658	5.003	5.886	ns
12 mA	slow	3.417	4.02	2.807	3.303	3.401	4.002	6.083	7.156	5.464	6.428	ns
	medium	3.076	3.618	2.519	2.964	3.063	3.604	5.828	6.856	5.176	6.089	ns
	medium_fast	2.913	3.427	2.376	2.795	2.898	3.41	5.725	6.736	5.072	5.966	ns
	fast	2.894	3.405	2.362	2.78	2.879	3.388	5.715	6.724	5.064	5.957	ns
16 mA	slow	3.366	3.96	2.751	3.237	3.348	3.939	6.226	7.324	5.576	6.56	ns
	medium	3.03	3.565	2.47	2.906	3.017	3.55	5.981	7.036	5.282	6.214	ns
	medium_fast	2.87	3.377	2.328	2.739	2.854	3.358	5.895	6.935	5.18	6.094	ns
	fast	2.853	3.357	2.314	2.723	2.837	3.338	5.889	6.929	5.177	6.09	ns

1. Delay increases with drive strength are inherent to built-in slew control circuitry for simultaneous switching output (SSO management).

### 2.3.7 Differential I/O Standards

Configuration of the I/O modules as a differential pair is handled by Microsemi SoC Products Group Libero software when the user instantiates a differential I/O macro in the design. Differential I/Os can also be used in conjunction with the embedded Input register (InReg), Output register (OutReg), Enable register (EnReg), and Double Data Rate registers (DDR).

#### 2.3.7.1 LVDS

Low-Voltage Differential Signaling (ANSI/TIA/EIA-644) is a high-speed, differential I/O standard.

##### Minimum and Maximum Input and Output Levels

**Table 160 • LVDS Recommended DC Operating Conditions**

Parameter	Symbol	Min	Typ	Max	Unit	Conditions
Supply voltage	$V_{DDI}$	2.375	2.5	2.625	V	2.5 V range
Supply voltage	$V_{DDI}$	3.15	3.3	3.45	V	3.3 V range

**Table 161 • LVDS DC Input Voltage Specification**

Parameter	Symbol	Min	Max	Unit	Conditions
DC Input voltage	$V_I$	0	2.925	V	2.5 V range
DC input voltage	$V_I$	0	3.45	V	3.3 V range
Input current high <sup>1</sup>	$I_{IH}$ (DC)				
Input current low <sup>1</sup>	$I_{IL}$ (DC)				

1. See Table 24, page 22.

**Table 191 • M-LVDS AC Switching Characteristics for Receiver (for MSIOD I/O Bank - Input Buffers)**

On-Die Termination (ODT)	T <sub>PY</sub>		Unit
	-1	-Std	
None	2.495	2.934	ns
100	2.495	2.935	ns

**Table 192 • M-LVDS AC Switching Characteristics for Transmitter (for MSIO I/O Bank - Output and Tristate Buffers)**

T <sub>DP</sub>		T <sub>ZL</sub>		T <sub>ZH</sub>		T <sub>HZ</sub>		T <sub>LZ</sub>		Unit
-1	-Std	-1	-Std	-1	-Std	-1	-Std	-1	-Std	
2.258	2.656	2.348	2.762	2.334	2.746	2.123	2.497	2.125	2.5	ns

### 2.3.7.4 Mini-LVDS

Mini-LVDS is an unidirectional interface from the timing controller to the column drivers and is designed to the Texas Instruments Standard SLDA007A.

#### Mini-LVDS Minimum and Maximum Input and Output Levels

**Table 193 • Mini-LVDS Recommended DC Operating Conditions**

Parameter	Symbol	Min	Typ	Max	Unit
Supply voltage	V <sub>DDI</sub>	2.375	2.5	2.625	V

**Table 194 • Mini-LVDS DC Input Voltage Specification**

Parameter	Symbol	Min	Max	Unit
DC input voltage	V <sub>I</sub>	0	2.925	V

**Table 195 • Mini-LVDS DC Output Voltage Specification**

Parameter	Symbol	Min	Typ	Max	Unit
DC output logic high	V <sub>OH</sub>	1.25	1.425	1.6	V
DC output logic low	V <sub>OL</sub>	0.9	1.075	1.25	V

**Table 196 • Mini-LVDS DC Differential Voltage Specification**

Parameter	Symbol	Min	Max	Unit
Differential output voltage swing	V <sub>OD</sub>	300	600	mV
Output common mode voltage	V <sub>OCM</sub>	1	1.4	V
Input common mode voltage	V <sub>ICM</sub>	0.3	1.2	V
Input differential voltage	V <sub>ID</sub>	100	600	mV

**Table 197 • Mini-LVDS Minimum and Maximum AC Switching Speed**

Parameter	Symbol	Max	Unit	Conditions
Maximum data rate (for MSIO I/O bank)	D <sub>MAX</sub>	520	Mbps	AC loading: 2 pF / 100 Ω differential load
Maximum data rate (for MSIOD I/O bank)	D <sub>MAX</sub>	700	Mbps	AC loading: 2 pF / 100 Ω differential load

**Table 222 • Output DDR Propagation Delays (continued)**

Symbol	Description	Measuring Nodes (from, to)	-1	-Std	Unit
$T_{DDROWAL}$	Asynchronous load minimum pulse width for output DDR	C, C	0.304	0.357	ns
$T_{DDROCKMPWH}$	Clock minimum pulse width high for the output DDR	E, E	0.075	0.088	ns
$T_{DDROCKMPWL}$	Clock minimum pulse width low for the output DDR	E, E	0.159	0.187	ns

## 2.3.10 Logic Element Specifications

### 2.3.10.1 4-input LUT (LUT-4)

The IGLOO2 and SmartFusion2 SoC FPGAs offer a fully permutable 4-input LUT. In this section, timing characteristics are presented for a sample of the library. For more details, see *SmartFusion2 and IGLOO2 Macro Library Guide*.

**Figure 14 • LUT-4**

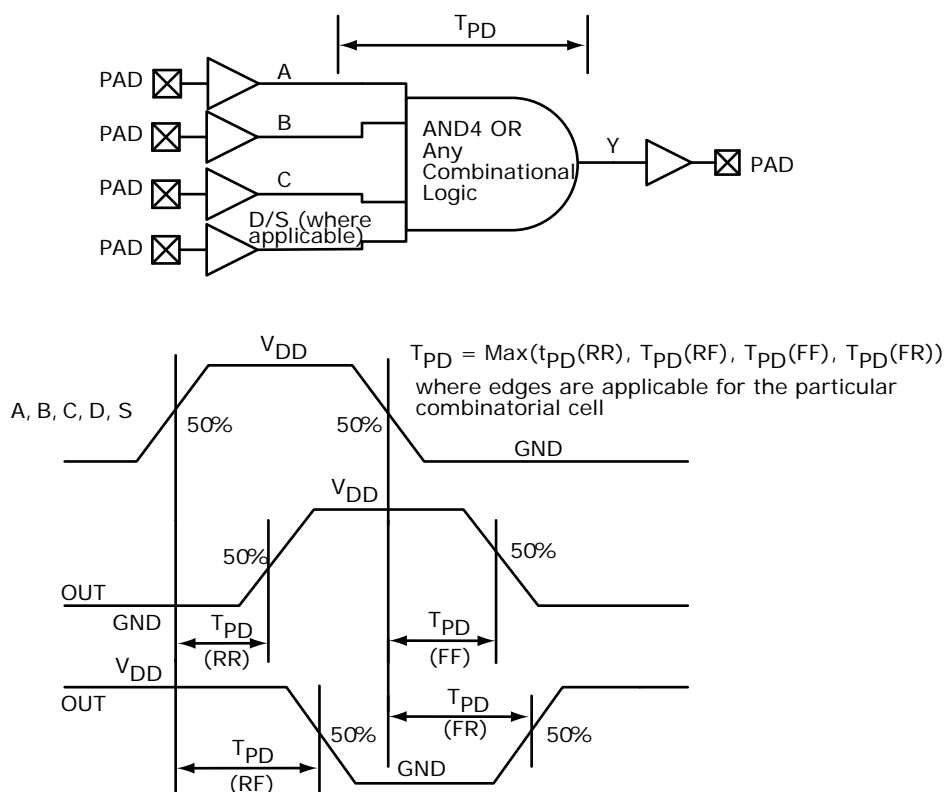

## 2.3.11 Global Resource Characteristics

The IGLOO2 and SmartFusion2 SoC FPGA devices offer a powerful, low skew global routing network which provides an effective clock distribution throughout the FPGA fabric. See *UG0445: IGLOO2 FPGA and SmartFusion2 SoC FPGA Fabric User Guide* for the positions of various global routing resources.

The following table lists the 150 device global resources in worst commercial-case conditions when  $T_J = 85\text{ }^\circ\text{C}$ ,  $V_{DD} = 1.14\text{ V}$ .

**Table 225 • 150 Device Global Resource**

Parameter	Symbol	-1		-Std		Unit
		Min	Max	Min	Max	
Input low delay for global clock	$T_{RCKL}$	0.83	0.911	0.831	0.913	ns
Input high delay for global clock	$T_{RCKH}$	1.457	1.588	1.715	1.869	ns
Maximum skew for global clock	$T_{RCKSW}$		0.131		0.154	ns

The following table lists the 090 device global resources in worst commercial-case conditions when  $T_J = 85\text{ }^\circ\text{C}$ ,  $V_{DD} = 1.14\text{ V}$ .

**Table 226 • 090 Device Global Resource**

Parameter	Symbol	-1		-Std		Unit
		Min	Max	Min	Max	
Input low delay for global clock	$T_{RCKL}$	0.835	0.888	0.833	0.886	ns
Input high delay for global clock	$T_{RCKH}$	1.405	1.489	1.654	1.752	ns
Maximum skew for global clock	$T_{RCKSW}$		0.084		0.098	ns

The following table lists the 050 device global resources in worst commercial-case conditions when  $T_J = 85\text{ }^\circ\text{C}$ ,  $V_{DD} = 1.14\text{ V}$ .

**Table 227 • 050 Device Global Resource**

Parameter	Symbol	-1		-Std		Unit
		Min	Max	Min	Max	
Input low delay for global clock	$T_{RCKL}$	0.827	0.897	0.826	0.896	ns
Input high delay for global clock	$T_{RCKH}$	1.419	1.53	1.671	1.8	ns
Maximum skew for global clock	$T_{RCKSW}$		0.111		0.129	ns

The following table lists the 025 device global resources in worst commercial-case conditions when  $T_J = 85\text{ }^\circ\text{C}$ ,  $V_{DD} = 1.14\text{ V}$ .

**Table 228 • 025 Device Global Resource**

Parameter	Symbol	-1		-Std		Unit
		Min	Max	Min	Max	
Input low delay for global clock	$T_{RCKL}$	0.747	0.799	0.745	0.797	ns
Input high delay for global clock	$T_{RCKH}$	1.294	1.378	1.522	1.621	ns
Maximum skew for global clock	$T_{RCKSW}$		0.084		0.099	ns

The following table lists the 010 device global resources in worst commercial-case conditions when  $T_J = 85\text{ }^\circ\text{C}$ ,  $V_{DD} = 1.14\text{ V}$ .

**Table 229 • 010 Device Global Resource**

Parameter	Symbol	-1		-Std		Unit
		Min	Max	Min	Max	
Input low delay for global clock	$T_{RCKL}$	0.626	0.669	0.627	0.668	ns
Input high delay for global clock	$T_{RCKH}$	1.112	1.182	1.308	1.393	ns
Maximum skew for global clock	$T_{RCKSW}$		0.07		0.085	ns

The following table lists the 005 device global resources in worst commercial-case conditions when  $T_J = 85\text{ }^\circ\text{C}$ ,  $V_{DD} = 1.14\text{ V}$ .

**Table 230 • 005 Device Global Resource**

Parameter	Symbol	-1		-Std		Unit
		Min	Max	Min	Max	
Input low delay for global clock	$T_{RCKL}$	0.625	0.66	0.628	0.66	ns
Input high delay for global clock	$T_{RCKH}$	1.126	1.187	1.325	1.397	ns
Maximum skew for global clock	$T_{RCKSW}$		0.061		0.072	ns

## 2.3.12 FPGA Fabric SRAM

See *UG0445: IGLOO2 FPGA and SmartFusion2 SoC FPGA Fabric User Guide* for more information.

### 2.3.12.1 FPGA Fabric Large SRAM (LSRAM)

The following table lists the RAM1K18 – dual-port mode for depth  $\times$  width configuration 1K  $\times$  18 in worst commercial-case conditions when  $T_J = 85\text{ }^\circ\text{C}$ ,  $V_{DD} = 1.14\text{ V}$ .

**Table 231 • RAM1K18 – Dual-Port Mode for Depth  $\times$  Width Configuration 1K  $\times$  18**

Parameter	Symbol	-1		-Std		Unit
		Min	Max	Min	Max	
Clock period	$T_{CY}$	2.5		2.941		ns
Clock minimum pulse width high	$T_{CLKMPWH}$	1.125		1.323		ns
Clock minimum pulse width low	$T_{CLKMPWL}$	1.125		1.323		ns
Pipelined clock period	$T_{PLCY}$	2.5		2.941		ns
Pipelined clock minimum pulse width high	$T_{PLCLKMPWH}$	1.125		1.323		ns
Pipelined clock minimum pulse width low	$T_{PLCLKMPWL}$	1.125		1.323		ns
Read access time with pipeline register				0.334	0.393	ns
Read access time without pipeline register	$T_{CLK2Q}$			2.273	2.674	ns
Access time with feed-through write timing				1.529	1.799	ns
Address setup time	$T_{ADDRSU}$	0.441		0.519		ns
Address hold time	$T_{ADDRHD}$	0.274		0.322		ns
Data setup time	$T_{DSU}$	0.341		0.401		ns
Data hold time	$T_{DHD}$	0.107		0.126		ns
Block select setup time	$T_{BLKSU}$	0.207		0.244		ns

**Table 232 • RAM1K18 – Dual-Port Mode for Depth × Width Configuration 2K × 9 (continued)**

Parameter	Symbol	–1		–Std		Unit
		Min	Max	Min	Max	
Address setup time	$T_{ADDRSU}$	0.475		0.559		ns
Address hold time	$T_{ADDRHD}$	0.274		0.322		ns
Data setup time	$T_{DSU}$	0.336		0.395		ns
Data hold time	$T_{DHD}$	0.082		0.096		ns
Block select setup time	$T_{BLKSU}$	0.207		0.244		ns
Block select hold time	$T_{BLKHD}$	0.216		0.254		ns
Block select to out disable time (when pipelined register is disabled)	$T_{BLK2Q}$		1.529		1.799	ns
Block select minimum pulse width	$T_{BLKMPW}$	0.186		0.219		ns
Read enable setup time	$T_{RDESU}$	0.485		0.57		ns
Read enable hold time	$T_{RDEHD}$	0.071		0.083		ns
Pipelined read enable setup time (A_DOUT_EN, B_DOUT_EN)	$T_{RDPLESU}$	0.248		0.291		ns
Pipelined read enable hold time (A_DOUT_EN, B_DOUT_EN)	$T_{RDPLEHD}$	0.102		0.12		ns
Asynchronous reset to output propagation delay	$T_{R2Q}$		1.514		1.781	ns
Asynchronous reset removal time	$T_{RSTREM}$	0.506		0.595		ns
Asynchronous reset recovery time	$T_{RSTREC}$	0.004		0.005		ns
Asynchronous reset minimum pulse width	$T_{RSTMPW}$	0.301		0.354		ns
Pipelined register asynchronous reset removal time	$T_{PLRSTREM}$	–0.279		–0.328		ns
Pipelined register asynchronous reset recovery time	$T_{PLRSTREC}$	0.327		0.385		ns
Pipelined register asynchronous reset minimum pulse width	$T_{PLRSTMPW}$	0.282		0.332		ns
Synchronous reset setup time	$T_{SRSTSU}$	0.226		0.265		ns
Synchronous reset hold time	$T_{SRSTHD}$	0.036		0.043		ns
Write enable setup time	$T_{WESU}$	0.415		0.488		ns
Write enable hold time	$T_{WEHD}$	0.048		0.057		ns
Maximum frequency	$F_{MAX}$		400		340	MHz

The following table lists the RAM1K18 – dual-port mode for depth × width configuration 4K × 4 in worst commercial-case conditions when  $T_J = 85\text{ }^\circ\text{C}$ ,  $V_{DD} = 1.14\text{ V}$ .

**Table 233 • RAM1K18 – Dual-Port Mode for Depth × Width Configuration 4K × 4**

Parameter	Symbol	–1		–Std		Unit
		Min	Max	Min	Max	
Clock period	$T_{CY}$	2.5		2.941		ns
Clock minimum pulse width high	$T_{CLKMPWH}$	1.125		1.323		ns
Clock minimum pulse width low	$T_{CLKMPWL}$	1.125		1.323		ns
Pipelined clock period	$T_{PLCY}$	2.5		2.941		ns
Pipelined clock minimum pulse width high	$T_{PLCLKMPWH}$	1.125		1.323		ns

The following table lists the RAM1K18 – dual-port mode for depth × width configuration 8K × 2 in worst commercial-case conditions when  $T_J = 85\text{ }^\circ\text{C}$ ,  $V_{DD} = 1.14\text{ V}$ .

**Table 234 • RAM1K18 – Dual-Port Mode for Depth × Width Configuration 8K × 2**

Parameter	Symbol	–1		–Std		Unit
		Min	Max	Min	Max	
Clock period	$T_{CY}$	2.5		2.941		ns
Clock minimum pulse width high	$T_{CLKMPWH}$	1.125		1.323		ns
Clock minimum pulse width low	$T_{CLKMPWL}$	1.125		1.323		ns
Pipelined clock period	$T_{PLCY}$	2.5		2.941		ns
Pipelined clock minimum pulse width high	$T_{PLCLKMPWH}$	1.125		1.323		ns
Pipelined clock minimum pulse width low	$T_{PLCLKMPWL}$	1.125		1.323		ns
Read access time with pipeline register				0.32	0.377	ns
Read access time without pipeline register	$T_{CLK2Q}$			2.272	2.673	ns
Access time with feed-through write timing				1.511	1.778	ns
Address setup time	$T_{ADDRSU}$	0.612		0.72		ns
Address hold time	$T_{ADDRHD}$	0.274		0.322		ns
Data setup time	$T_{DSU}$	0.33		0.388		ns
Data hold time	$T_{DHD}$	0.082		0.096		ns
Block select setup time	$T_{BLKSU}$	0.207		0.244		ns
Block select hold time	$T_{BLKHD}$	0.216		0.254		ns
Block select to out disable time (when pipelined register is disabled)	$T_{BLK2Q}$			1.511	1.778	ns
Block select minimum pulse width	$T_{BLKMPW}$	0.186		0.219		ns
Read enable setup time	$T_{RDESU}$	0.529		0.622		ns
Read enable hold time	$T_{RDEHD}$	0.071		0.083		ns
Pipelined read enable setup time (A_DOUT_EN, B_DOUT_EN)	$T_{RDPLESU}$	0.248		0.291		ns
Pipelined read enable hold time (A_DOUT_EN, B_DOUT_EN)	$T_{RDPLEHD}$	0.102		0.12		ns
Asynchronous reset to output propagation delay	$T_{R2Q}$			1.528	1.797	ns
Asynchronous reset removal time	$T_{RSTREM}$	0.506		0.595		ns
Asynchronous reset recovery time	$T_{RSTREC}$	0.004		0.005		ns
Asynchronous reset minimum pulse width	$T_{RSTMPW}$	0.301		0.354		ns
Pipelined register asynchronous reset removal time	$T_{PLRSTREM}$	–0.279		–0.328		ns
Pipelined register asynchronous reset recovery time	$T_{PLRSTREC}$	0.327		0.385		ns
Pipelined register asynchronous reset minimum pulse width	$T_{PLRSTMPW}$	0.282		0.332		ns
Synchronous reset setup time	$T_{SRSTSU}$	0.226		0.265		ns
Synchronous reset hold time	$T_{SRSTHD}$	0.036		0.043		ns
Write enable setup time	$T_{WESU}$	0.488		0.574		ns
Write enable hold time	$T_{WEHD}$	0.048		0.057		ns
Maximum frequency	$F_{MAX}$			400	340	MHz

### 2.3.12.2 FPGA Fabric Micro SRAM ( $\mu$ SRAM)

The following table lists the  $\mu$ SRAM in  $64 \times 18$  mode in worst commercial-case conditions when  $T_J = 85^\circ\text{C}$ ,  $V_{DD} = 1.14\text{ V}$ .

**Table 237 •  $\mu$ SRAM (RAM64x18) in  $64 \times 18$  Mode**

Parameter	Symbol	-1		-Std		Unit
		Min	Max	Min	Max	
Read clock period	$T_{CY}$	4		4		ns
Read clock minimum pulse width high	$T_{CLKMPWH}$	1.8		1.8		ns
Read clock minimum pulse width low	$T_{CLKMPWL}$	1.8		1.8		ns
Read pipeline clock period	$T_{PLCY}$	4		4		ns
Read pipeline clock minimum pulse width high	$T_{PLCLKMPWH}$	1.8		1.8		ns
Read pipeline clock minimum pulse width low	$T_{PLCLKMPWL}$	1.8		1.8		ns
Read access time with pipeline register	$T_{CLK2Q}$		0.266		0.313	ns
Read access time without pipeline register				1.677		1.973
Read address setup time in synchronous mode	$T_{ADDRSU}$	0.301		0.354		ns
Read address setup time in asynchronous mode			1.856		2.184	
Read address hold time in synchronous mode	$T_{ADDRHD}$	0.091		0.107		ns
Read address hold time in asynchronous mode			-0.778		-0.915	
Read enable setup time	$T_{RDENSU}$	0.278		0.327		ns
Read enable hold time	$T_{RDENHD}$	0.057		0.067		ns
Read block select setup time	$T_{BLKSU}$	1.839		2.163		ns
Read block select hold time	$T_{BLKHD}$	-0.65		-0.765		ns
Read block select to out disable time (when pipelined register is disabled)	$T_{BLK2Q}$		2.036		2.396	ns
Read asynchronous reset removal time (pipelined clock)	$T_{RSTREM}$	-0.023		-0.027		ns
Read asynchronous reset removal time (non-pipelined clock)			0.046		0.054	
Read asynchronous reset recovery time (pipelined clock)	$T_{RSTREC}$	0.507		0.597		ns
Read asynchronous reset recovery time (non-pipelined clock)			0.236		0.278	
Read asynchronous reset to output propagation delay (with pipelined register enabled)	$T_{R2Q}$		0.839		0.987	ns
Read synchronous reset setup time	$T_{SRSTSU}$	0.271		0.319		ns
Read synchronous reset hold time	$T_{SRSTHD}$	0.061		0.071		ns
Write clock period	$T_{CCY}$	4		4		ns
Write clock minimum pulse width high	$T_{CCLKMPWH}$	1.8		1.8		ns
Write clock minimum pulse width low	$T_{CCLKMPWL}$	1.8		1.8		ns
Write block setup time	$T_{BLKCSU}$	0.404		0.476		ns
Write block hold time	$T_{BLKCHD}$	0.007		0.008		ns
Write input data setup time	$T_{DINCSU}$	0.115		0.135		ns
Write input data hold time	$T_{DINCHD}$	0.15		0.177		ns



**Table 237 •  $\mu$ SRAM (RAM64x18) in 64 × 18 Mode (continued)**

Parameter	Symbol	-1		-Std		Unit
		Min	Max	Min	Max	
Write address setup time	$T_{ADDRCSU}$	0.088		0.104		ns
Write address hold time	$T_{ADDRCHD}$	0.128		0.15		ns
Write enable setup time	$T_{WECSU}$	0.397		0.467		ns
Write enable hold time	$T_{WECHD}$	-0.026		-0.03		ns
Maximum frequency	$F_{MAX}$		250		250	MHz

The following table lists the  $\mu$ SRAM in 64 × 16 mode in worst commercial-case conditions when  $T_J = 85\text{ }^\circ\text{C}$ ,  $V_{DD} = 1.14\text{ V}$ .

**Table 238 •  $\mu$ SRAM (RAM64x16) in 64 × 16 Mode**

Parameter	Symbol	-1		-Std		Unit
		Min	Max	Min	Max	
Read clock period	$T_{CY}$	4		4		ns
Read clock minimum pulse width high	$T_{CLKMPWH}$	1.8		1.8		ns
Read clock minimum pulse width low	$T_{CLKMPWL}$	1.8		1.8		ns
Read pipeline clock period	$T_{PLCY}$	4		4		ns
Read pipeline clock minimum pulse width high	$T_{PLCLKMPWH}$	1.8		1.8		ns
Read pipeline clock minimum pulse width low	$T_{PLCLKMPWL}$	1.8		1.8		ns
Read access time with pipeline register	$T_{CLK2Q}$		0.266		0.313	ns
Read access time without pipeline register				1.677		1.973
Read address setup time in synchronous mode	$T_{ADDRSU}$	0.301		0.354		ns
Read address setup time in asynchronous mode			1.856		2.184	
Read address hold time in synchronous mode	$T_{ADDRHD}$	0.091		0.107		ns
Read address hold time in asynchronous mode			-0.778		-0.915	
Read enable setup time	$T_{RDENSU}$	0.278		0.327		ns
Read enable hold time	$T_{RDENHD}$	0.057		0.067		ns
Read block select setup time	$T_{BLKSU}$	1.839		2.163		ns
Read block select hold time	$T_{BLKHD}$	-0.65		-0.765		ns
Read block select to out disable time (when pipelined register is disabled)	$T_{BLK2Q}$		2.036		2.396	ns
Read asynchronous reset removal time (pipelined clock)	$T_{RSTREM}$	-0.023		-0.027		ns
Read asynchronous reset removal time (non-pipelined clock)			0.046		0.054	
Read asynchronous reset recovery time (pipelined clock)	$T_{RSTREC}$	0.507		0.597		ns
Read asynchronous reset recovery time (non-pipelined clock)			0.236		0.278	
Read asynchronous reset to output propagation delay (with pipelined register enabled)	$T_{R2Q}$		0.835		0.983	ns
Read synchronous reset setup time	$T_{SRSTSU}$	0.271		0.319		ns

**Table 265 • Programming Times with 100 kHz, 25 MHz. and 12.5 MHz SPI Clock Rates (Fabric Only)**

M2S/M2GL Device	Auto Programming			Unit
	100 kHz	25 MHz	12.5 MHz	
005	69	49	50	Sec
010	99	57	57	Sec
025	150	64	63	Sec
050	55 <sup>1</sup>	Not Supported	Not Supported	Sec
060	313	105	104	Sec
090	449	131	130	Sec
150	730	179	183	Sec

1. Auto programming in 050 device is done through SC\_SPI, and SPI CLK is set to 6.25 MHz.

**Table 266 • Programming Times with 100 kHz, 25 MHz. and 12.5 MHz SPI Clock Rates (eNVM Only)**

M2S/M2GL Device	Auto Programming			Unit
	100 kHz	25 MHz	12.5 MHz	
005	63	70	71	Sec
010	108	109	109	Sec
025	109	107	108	Sec
050	107	Not Supported	Not Supported	Sec
060	100	108	108	Sec
090	176	184	184	Sec
150	183	183	183	Sec

**Table 267 • Programming Times with 100 kHz, 25 MHz. and 12.5 MHz SPI Clock Rates (Fabric and eNVM)**

M2S/M2GL Device	Auto Programming			Unit
	100 kHz	25 MHz	12.5 MHz	
005	109	89	88	Sec
010	183	135	135	Sec
025	251	142	143	Sec
050	134	Not Supported	Not Supported	Sec
060	390	183	180	Sec
090	604	283	282	Sec
150	889	331	332	Sec

### 2.3.30 SerDes Electrical and Timing AC and DC Characteristics

PCIe is a high-speed, packet-based, point-to-point, low-pin-count, serial interconnect bus. The IGLOO2 and SmartFusion2 SoC FPGAs has up to four hard high-speed serial interface blocks. Each SerDes block contains a PCIe system block. The PCIe system is connected to the SerDes block.

The following table lists the transmitter parameters in worst-case industrial conditions when  $T_J = 100\text{ }^\circ\text{C}$ ,  $V_{DD} = 1.14\text{ V}$ .

**Table 296 • Transmitter Parameters**

Symbol	Description	Min	Max	Unit
VTX-DIFF-PP	Differential swing (2.5 Gbps, 5.0 Gbps)	0.8	1.2	V
VTX-CM-AC-P	Output common mode voltage (2.5 Gbps)		20	mV
VTX-CM-AC-PP	Output common mode voltage (5.0 Gbps)		100	mV
VTX-RISE-FALL	Rise and fall time (20% to 80%, 2.5 Gbps)	0.125		UI
	Rise and fall time (20% to 80%, 5.0 Gbps)	0.15		UI
ZTX-DIFF-DC	Output impedance–differential	80	120	$\Omega$
LTX-SKEW	Lane-to-lane TX skew within a SerDes block (2.5 Gbps)		500 ps + 2 UI	ps
	Lane-to-lane TX skew within a SerDes block (5.0 Gbps)		500 ps + 4 UI	ps
RLTX-DIFF	Return loss differential mode (2.5 Gbps)	–10		dB
	Return loss differential mode (5.0 Gbps) 0.05 GHz to 1.25 GHz	–10		dB
	1.25 GHz to 2.5 GHz	–8		dB
RLTX-CM	Return loss common mode (2.5 Gbps, 5.0 Gbps)	–6		dB
TX-LOCK-RST	Transmit PLL lock time from reset		10	$\mu\text{s}$
VTX-AMP	100 mV setting	90	150	mV
	400 mV setting	320	480	mV
	800 mV setting	660	940	mV
	1200 mV setting	950	1400	mV

## 2.3.34 MMUART Characteristics

The following table lists the MMUART characteristics in worst-case industrial conditions when  $T_J = 100\text{ }^\circ\text{C}$ ,  $V_{DD} = 1.14\text{ V}$ .

**Table 308 • MMUART Characteristics**

Parameter	Description	-1	-Std	Unit
FMMUART_REF_CLK	Internally sourced MMUART reference clock frequency.	166	142	MHz
BAUDMMUARTTx	Maximum transmit baud rate	10.375	8.875	Mbps
BAUDMMUARTRx	Maximum receive baud rate	10.375	8.875	Mbps

## 2.3.35 IGLOO2 Specifications

### 2.3.35.1 HPMS Clock Frequency

The following table lists the maximum frequency for HPMS main clock in worst-case industrial conditions when  $T_J = 100\text{ }^\circ\text{C}$ ,  $V_{DD} = 1.14\text{ V}$ .

**Table 309 • Maximum Frequency for HPMS Main Clock**

Symbol	Description	-1	-Std	Unit
HPMS_CLK	Maximum frequency for the HPMS main clock	166	142	MHz

### 2.3.35.2 IGLOO2 Serial Peripheral Interface (SPI) Characteristics

This section describes the DC and switching of the SPI interface. Unless otherwise noted, all output characteristics given are for a 35 pF load on the pins and all sequential timing characteristics are related to SPI\_0\_CLK. For timing parameter definitions, see Figure 23, page 131.

The following table lists the SPI characteristics in worst-case industrial conditions when  $T_J = 100\text{ }^\circ\text{C}$ ,  $V_{DD} = 1.14\text{ V}$ .

**Table 310 • SPI Characteristics for All Devices**

Symbol	Description	Min	Typ	Max	Unit	Conditions
SPIFMAX	Maximum operating frequency of SPI interface			20	MHz	
sp1	SPI_[0 1]_CLK minimum period					
	SPI_[0 1]_CLK = PCLK/2	12			ns	
	SPI_[0 1]_CLK = PCLK/4	24.1			ns	
	SPI_[0 1]_CLK = PCLK/8	48.2			ns	
	SPI_[0 1]_CLK = PCLK/16	0.1			$\mu\text{s}$	
	SPI_[0 1]_CLK = PCLK/32	0.19			$\mu\text{s}$	
	SPI_[0 1]_CLK = PCLK/64	0.39			$\mu\text{s}$	
SPI_[0 1]_CLK = PCLK/128	0.77			$\mu\text{s}$		

**Table 310 • SPI Characteristics for All Devices (continued)**

Symbol	Description	Min	Typ	Max	Unit	Conditions
sp2	SPI_[0 1]_CLK minimum pulse width high					
	SPI_[0 1]_CLK = PCLK/2	6			ns	
	SPI_[0 1]_CLK = PCLK/4	12.05			ns	
	SPI_[0 1]_CLK = PCLK/8	24.1			ns	
	SPI_[0 1]_CLK = PCLK/16	0.05			µs	
	SPI_[0 1]_CLK = PCLK/32	0.095			µs	
	SPI_[0 1]_CLK = PCLK/64	0.195			µs	
	SPI_[0 1]_CLK = PCLK/128	0.385			µs	
sp3	SPI_[0 1]_CLK minimum pulse width low					
	SPI_[0 1]_CLK = PCLK/2	6			ns	
	SPI_[0 1]_CLK = PCLK/4	12.05			ns	
	SPI_[0 1]_CLK = PCLK/8	24.1			ns	
	SPI_[0 1]_CLK = PCLK/16	0.05			µs	
	SPI_[0 1]_CLK = PCLK/32	0.095			µs	
	SPI_[0 1]_CLK = PCLK/64	0.195			µs	
	SPI_[0 1]_CLK = PCLK/128	0.385			µs	
sp4	SPI_[0 1]_CLK, SPI_[0 1]_DO, SPI_[0 1]_SS rise time (10%–90%) <sup>1</sup>		2.77		ns	I/O Configuration: LVCMOS 2.5 V - 8 mA AC loading: 35 pF test conditions: Typical voltage, 25 °C
sp5	SPI_[0 1]_CLK, SPI_[0 1]_DO, SPI_[0 1]_SS fall time (10%–90%) <sup>1</sup>		2.906		ns	I/O Configuration: LVCMOS 2.5 V - 8 mA AC loading: 35 pF test conditions: Typical voltage, 25 °C
SPI master configuration (applicable for 005, 010, 025, and 050 devices)						
sp6m	SPI_[0 1]_DO setup time <sup>2</sup>	(SPI_x_CLK_period/2) – 8.0			ns	
sp7m	SPI_[0 1]_DO hold time <sup>2</sup>	(SPI_x_CLK_period/2) – 2.5			ns	
sp8m	SPI_[0 1]_DI setup time <sup>2</sup>	12			ns	
sp9m	SPI_[0 1]_DI hold time <sup>2</sup>	2.5			ns	
SPI slave configuration (applicable for 005, 010, 025, and 050 devices)						
sp6s	SPI_[0 1]_DO setup time <sup>2</sup>	(SPI_x_CLK_period/2) – 17.0			ns	
sp7s	SPI_[0 1]_DO hold time <sup>2</sup>	(SPI_x_CLK_period/2) + 3.0			ns	
sp8s	SPI_[0 1]_DI setup time <sup>2</sup>	2			ns	
sp9s	SPI_[0 1]_DI hold time <sup>2</sup>	7			ns	