



Welcome to E-XFL.COM

Understanding [Embedded - Microcontroller, Microprocessor, FPGA Modules](#)

Embedded - Microcontroller, Microprocessor, and FPGA Modules are fundamental components in modern electronic systems, offering a wide range of functionalities and capabilities. Microcontrollers are compact integrated circuits designed to execute specific control tasks within an embedded system. They typically include a processor, memory, and input/output peripherals on a single chip. Microprocessors, on the other hand, are more powerful processing units used in complex computing tasks, often requiring external memory and peripherals. FPGAs (Field Programmable Gate Arrays) are highly flexible devices that can be configured by the user to perform specific logic functions, making them invaluable in applications requiring customization and adaptability.

Applications of [Embedded - Microcontroller,](#)

Details

Product Status	Discontinued at Digi-Key
Module/Board Type	FPGA Core
Core Processor	Artix-7 A200T
Co-Processor	-
Speed	-
Flash Size	32MB
RAM Size	256KB
Connector Type	SO-DIMM-204
Size / Dimension	2.7" x 2.0" (68mm x 51mm)
Operating Temperature	0°C ~ 85°C
Purchase URL	https://www.e-xfl.com/product-detail/soc-technologies/dc-va-h264-10b-60-1080-mxc-ll

6. The H.264 4K Encoder Modules

- 6.1 Pin Assignments and Pin Voltages**
- 6.2 Signal Formats**
 - 6.2.1 Clock Signals (Input, Output)**
 - 6.2.2 Video Data Signals (Input)**
 - 6.2.3 Audio Data Signals (Input)**
 - 6.2.4 TS Signals (Output)**
 - 6.2.5 Encoder Control Signals (Input and Output)**
- 6.3 Power Rails of MCM-1000Z**
- 6.4 Power Requirement and Supply Amperage**

7. The H.264 4K Decoder Modules

- 7.1 Pin Assignments and Pin Voltages**
- 7.2 Signal Formats**
 - 7.2.1 Video Clock Signal (Input)**
 - 7.2.2 Video Data Signals (Output)**
 - 7.2.3 Audio Data Signals (Output)**
 - 7.2.4 TS Signals (Input)**
 - 7.2.5 Decoder Control Signals (Input and Output)**
- 7.3 Power Rails of MCM-1000Z**
- 7.4 Power Requirement and Supply Amperage**

8. The H.265 HD Encoder Modules

- 8.1 Pin Assignments and Pin Voltages**
- 8.2 Signal Formats**
 - 8.2.1 Clock Signal (Input)**
 - 8.2.2 Video Data Signals (Input)**
 - 8.2.3 Audio Data Signals (Input)**
 - 8.2.4 TS Signals (Output)**
 - 8.2.5 Encoder Control Signals (Input and Output)**
- 8.3 Power Rails of MCM-1000SX**
- 8.4 Power Requirement and Supply Amperage**

9. The H.265 HD Decoder Modules

- 9.1 Pin Assignments and Pin Voltages**
- 9.2 Signal Formats**
 - 9.2.1 Clock Signal (Input)**
 - 9.2.2 Video Data Signals (Output)**
 - 9.2.3 Audio Data Signals (Output)**
 - 9.2.4 TS Signals (Input)**
 - 9.2.5 Encoder Control Signals (Input and Output)**
- 9.3 Power Rails of MCM-1000SX**
- 9.4 Power Requirement and Supply Amperage**

10. The H.265 4K Encoder Modules

- 10.1 Pin Assignments and Pin Voltages**
- 10.2 Signal Formats**
 - 10.2.1 Clock Signals (Input, Output)**
 - 10.2.2 Video Data Signals (Input)**
 - 10.2.3 Audio Data Signals (Input)**
 - 10.2.4 TS Signals (Output)**
 - 10.2.5 Decoder Control Signals (Input and Output)**
- 10.3 Power Rails of MCM-1000SX**
- 10.4 Power Requirement and Supply Amperage**

11. The H.265 4K Decoder Modules

- 11.1 Pin Assignments and Pin Voltages**
- 11.2 Signal Formats**
 - 11.2.1 Clock Signals (Input, Output)**
 - 11.2.2 Video Data Signals (Output)**
 - 11.2.3 Audio Data Signals (Output)**
 - 11.2.4 TS Signals (Input)**
 - 11.2.5 Decoder Control Signals (Input and Output)**
- 11.3 Power Rails of MCM-1000SX**
- 11.4 Power Requirement and Supply Amperage**

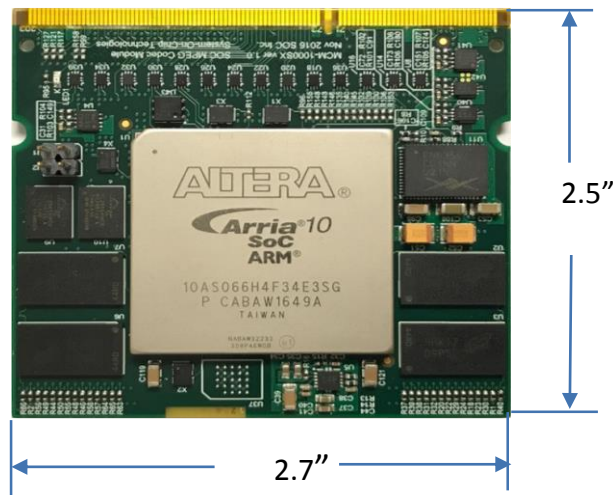

Fig. 5. Dimension of MCM-1000SX

2. Connecting the Module to a User PCB

The MCM-1000S/A/Z/SX modules have identical edge pins that are compatible with standard DDR3 SODIMM connectors. The following off-the-shelf DDR3 SODIMM connectors can be used to connect the SOC codec modules onto a user PCB:

1. MM80-204B1-1
2. MM80-204B1-1E
3. AS0A621-U2SN-7F
4. AS0A621-H2S6-7H

Fig. 6 shows a photo of a standard 204 pin DDR3 SODIMM PCB connector. Refer to the datasheet of the connector used for the physical dimension and PCB design requirements.



Fig. 6 A photo of the standard 204 pin DDR3 SODIMM connector

to **Video Data Chroma[9]**, for the Chroma. The precision can be either 8-bit or 10-bit. When 8-bit precision is used, **Video Data Luma[0]**, **Video Data Luma[1]**, **Video Data Chroma[0]**, and **Video Data Chroma[1]** are zeros.

In addition to the video Luma and Chroma data signals, the **Video Horizontal Sync** and **Video Vertical Sync** signals are provided for frame synchronization. A **Video Clock** (refer to Section 5.2.1 for the clock frequencies) is sent out, which provides the timing for the parallel inputs of luma, chroma, as well as the **Video Horizontal Sync** and **Video Vertical Sync signals**. The **Video Display Enable** signal (pin #150) is a part of the **Video Horizontal Sync** and **Video Vertical Sync** system, where high signal indicates active video pixels.

Output data are sampled at the rising edge of the clock. (The clock rates will correspond to the resolution and frame rate, as discussed in Section 5.2.1.)

5.2.3 Audio Data Signals (Output)

Line **SPDIF Audio** is for PCM audio output, in **SPDIF** frames. An **SPDIF** transmitter is included in the module to send the PCM data out via the decoder edge pins. Refer to the **SPDIF** protocol documents for details.

5.2.4 TS Stream Signals (Input)

The input of the decoder module is an MPEG transport stream, which is sent into the module by 8 parallel lines: **Transport Stream Data[0]** to **Transport Stream Data[7]**. **Transport Stream Clock** (27MHz) is the clock for the **Transport Stream Data** lines. The **Transport Stream Data Valid** signal informs the decoder that the input is valid.

5.2.5 Decoder Control Signals (Input and Output)

Uart_rx and **Uart_tx** are the API pins for controlling the operations of the decoder. **Uart_rx** receives the command from external control device. **Uart_tx** send the decoder information to the control device. Refer to the **Uart** standard for details of **Uart** operations. The SOC API User Manual provides the register map for the API control. Refer to the [Decoder API User Manual](#) for details.

5.3 Power Rails of MCM-1000A

The power rails for the HD (H.264 or MPEG-2) decoder module is the same as the ones for the HD encoder module. Refer to Table-2 for the power and ground pins. Also, refer to Appendix-A for the power and ground pins on the edge connector of the MCM-1000A module.

5.4 Power Requirement and Supply Amperage

The total power at operation required by a given decoder ranges from 2 to 4 Watts, depending on the resolution and frame rate. Since the total power is delivered over 6 power rails, each individual power rail delivers only a portion of the total lower. However, the power is not evenly distributed among the rails. Table-5 lists the power

estimation by Xilinx Vivado FPGA software for each rail, at 1080p@60 resolution, and can be used as a reference for PCB design. It should be noted that the estimated total power showing in Table-5 is higher than the measured real power.

Again, the power rails of 1.8v is generated on the module, using the 2.5v power input from the edge pin. PCB designers need only to design the 6 power rails listed in Table-5.

Table-5: Power estimation for the decoder module (1080p@60 resolution)

Power Supply				
Supply Source	Voltage (V)	Total (A)	Dynamic (A)	Static (A)
Vccint	1.000	2.421	2.362	0.058
Vccaux	1.800	0.497	0.464	0.033
Vcco33	3.300	0.053	0.048	0.005
Vcco25	2.500	0.000	0.000	0.000
Vcco18	1.800	0.000	0.000	0.000
Vcco15	1.500	0.500	0.495	0.005
Vcco135	1.350	0.000	0.000	0.000
Vcco12	1.200	0.000	0.000	0.000
Vccaux_io	1.800	0.000	0.000	0.000
Vccbram	1.000	0.037	0.028	0.009
MGTAVcc	1.000	0.000	0.000	0.000
MGTAVtt	1.200	0.000	0.000	0.000
Vccadc	1.800	0.022	0.002	0.020

Since the decoder module normally shares the power supplies with the carrier board (user PCB). The power design should be considered for both. SOC licenses the schematics of carrier boards, such as the VTR-S1000 and VTR-4000C discussed in Section 6 of this document. The reference designs not only provide the power system design, but also the I/O port designs, such as SDI, HDMI, Mini-USB, etc. Contact SOC sale at: sales@soctechnologies.com for further details.

6. The H.264 4k Encoder Modules

6.1 Pin Assignments and Pin Voltages

The modules for 4K resolution uses the MCM-1000Z hardware, with the MCM-1000Z35 (Zynq-7035 FPGA) for 4k@30 and MCM-1000Z45 (Zynq-7045 FPGA) for 4k@60. The pin assignment and electrical properties are the same for MCM-1000Z35 and MCM-1000Z45.

Table-6 lists the pin assignments and the pin voltages for the 4K encoder modules based on the MCM-1000Z (MCM-1000Z35 and MCM-1000Z45 are the same).

The schematics of MCM-1000Z edge connector are attached in Appendix-C of this document, which shows the pin numbers for data, clock, control, and power.

Table-6 also lists the FPGA pin numbers that are connected to the edge pins assigned to the encoder. The Zynq-7000 datasheet provides further information regarding the properties of these pins, and can be used as a reference.

Table-6: 4K Encoder Module (based on MCM-1000Z) Pin Assignment and Pin Voltages

Description	MCM-1000Z Edge Connector Pin #	Direction	FPGA Pin #	Voltage	IO Standard
PS Soft Reset B	156	Input	B19	3.3V	LVC MOS33
Video Clock 0	63	Input	AC18	1.5v	LVC MOS15
Video Clock 1	80	Input	AF15	3.3v	LVC MOS33
Video Clock 2	144	Input	AE28	3.3v	LVC MOS33
Video Clock 3	105	Input	AG21	3.3v	LVC MOS33
Video Horizontal Sync	133	Input	W24	1.5v	LVC MOS15
Video Vertical Sync	113	Input	AF22	3.3v	LVC MOS33
Video Display Enable	67	Input	AD18	1.5v	LVC MOS15
Video Data 0 Luma[0]	135	Input	W25	1.5v	LVC MOS15
Video Data 0 Luma[1]	137	Input	W26	1.5v	LVC MOS15
Video Data 0 Luma[2]	116	Input	V27	1.5v	LVC MOS15
Video Data 0 Luma[3]	118	Input	W28	1.5v	LVC MOS15
Video Data 0 Luma[4]	124	Input	W29	1.5v	LVC MOS15
Video Data 0 Luma[5]	126	Input	W30	1.5v	LVC MOS15
Video Data 0 Luma[6]	128	Input	V28	1.5v	LVC MOS15
Video Data 0 Luma[7]	130	Input	V29	1.5v	LVC MOS15
Video Data 0 Luma[8]	132	Input	T30	1.5v	LVC MOS15
Video Data 0 Luma[9]	134	Input	U30	1.5v	LVC MOS15
Video Data 1 Luma[0]	117	Input	AG22	3.3v	LVC MOS33
Video Data 1 Luma[1]	119	Input	AH22	3.3v	LVC MOS33
Video Data 1 Luma[2]	121	Input	AJ21	3.3v	LVC MOS33
Video Data 1 Luma[3]	123	Input	AK21	3.3v	LVC MOS33

Video Data 1 Luma[4]	125	Input	AF23	3.3v	LVC MOS33
Video Data 1 Luma[5]	127	Input	AF24	3.3v	LVC MOS33
Video Data 1 Luma[6]	92	Input	AJ23	3.3v	LVC MOS33
Video Data 1 Luma[7]	94	Input	AJ24	3.3v	LVC MOS33
Video Data 1 Luma[8]	96	Input	AG24	3.3v	LVC MOS33
Video Data 1 Luma[9]	98	Input	AG25	3.3v	LVC MOS33
Video Data 2 Luma[0]	77	Input	AJ16	3.3v	LVC MOS33
Video Data 2 Luma[1]	79	Input	AK16	3.3v	LVC MOS33
Video Data 2 Luma[2]	81	Input	AH17	3.3v	LVC MOS33
Video Data 2 Luma[3]	83	Input	AH16	3.3v	LVC MOS33
Video Data 2 Luma[4]	85	Input	AH18	3.3v	LVC MOS33
Video Data 2 Luma[5]	87	Input	AJ18	3.3v	LVC MOS33
Video Data 2 Luma[6]	78	Input	AF13	3.3v	LVC MOS33
Video Data 2 Luma[7]	82	Input	AG15	3.3v	LVC MOS33
Video Data 2 Luma[8]	84	Input	AG17	3.3v	LVC MOS33
Video Data 2 Luma[9]	86	Input	AG16	3.3v	LVC MOS33
Video Data 3 Luma[0]	107	Input	AH21	3.3v	LVC MOS33
Video Data 3 Luma[1]	122	Input	AH29	3.3v	LVC MOS33
Video Data 3 Luma[2]	115	Input	AE22	3.3v	LVC MOS33
Video Data 3 Luma[3]	146	Input	AF28	3.3v	LVC MOS33
Video Data 3 Luma[4]	148	Input	AF29	3.3v	LVC MOS33
Video Data 3 Luma[5]	150	Input	AG29	3.3v	LVC MOS33
Video Data 3 Luma[6]	100	Input	AH23	3.3v	LVC MOS33
Video Data 3 Luma[7]	102	Input	AH24	3.3v	LVC MOS33
Video Data 3 Luma[8]	104	Input	AJ25	3.3v	LVC MOS33
Video Data 3 Luma[9]	106	Input	AK25	3.3v	LVC MOS33
Video Data 0 Chroma[0]	143	Input	T29	1.5v	LVC MOS15
Video Data 0 Chroma[1]	145	Input	U29	1.5v	LVC MOS15
Video Data 0 Chroma[2]	147	Input	R28	1.5v	LVC MOS15
Video Data 0 Chroma[3]	149	Input	T28	1.5v	LVC MOS15
Video Data 0 Chroma[4]	151	Input	P30	1.5v	LVC MOS15
Video Data 0 Chroma[5]	153	Input	R30	1.5v	LVC MOS15
Video Data 0 Chroma[6]	155	Input	N29	1.5v	LVC MOS15
Video Data 0 Chroma[7]	157	Input	P29	1.5v	LVC MOS15
Video Data 0 Chroma[8]	159	Input	N28	1.5v	LVC MOS15
Video Data 0 Chroma[9]	161	Input	P28	1.5v	LVC MOS15
Video Data 1 Chroma[0]	89	Input	AK17	3.3v	LVC MOS33
Video Data 1 Chroma[1]	91	Input	AK18	3.3v	LVC MOS33
Video Data 1 Chroma[2]	93	Input	AF19	3.3v	LVC MOS33
Video Data 1 Chroma[3]	95	Input	AG19	3.3v	LVC MOS33
Video Data 1 Chroma[4]	97	Input	AH19	3.3v	LVC MOS33
Video Data 1 Chroma[5]	99	Input	AJ19	3.3v	LVC MOS33
Video Data 1 Chroma[6]	101	Input	AF20	3.3v	LVC MOS33
Video Data 1 Chroma[7]	103	Input	AG20	3.3v	LVC MOS33
Video Data 1 Chroma[8]	109	Input	AJ20	3.3v	LVC MOS33
Video Data 1 Chroma[9]	111	Input	AK20	3.3v	LVC MOS33
Video Data 2 Chroma[0]	38	Input	AE12	3.3v	LVC MOS33
Video Data 2 Chroma[1]	40	Input	AF12	3.3v	LVC MOS33

Chroma[9], for the Chroma. The precision is either 8 bits or 10 bits. For 8-bit precision, the Most Significant Luma and Chroma pins (Luma[2] to Luma[9], Chroma[2] to Chroma[9]) are used.

In addition to the video Luma and Chroma data signals, the **Video Horizontal Sync** and **Video Vertical Sync** signals are required for frame synchronization if embedded SAV/EAV are not used. The video clocks (refer to Section 6.2.1) provide the timing for the parallel input of luma, chroma, as well as the **Video Horizontal Sync** and **Video Vertical Sync** signals. The **Video Display Enable** signal is a part of the **Video Horizontal Sync** and **Video Vertical Sync** system, where high signal indicates active video pixels. For example, an HDMI input interface chip will output the **Video Display Enable** signal at high, when active pixels are being sent out.

The video data are sampled at the rising edge of the clock. The clock rates will correspond to the resolution and frame rate, as discussed in Section 6.2.1.

6.2.3 Audio Data Signals (Input)

Input line **SPDIF Audio** is for PCM audio input, in **SPDIF** frames. An **SPDIF** transmitter is required to send the PCM data to the encoder module. Refer to the **SPDIF** protocol documents for details.

6.2.4 TS stream Signals (Output)

The output of the encoder module is MPEG Transport Stream (TS), which is sent out from the module by 8 parallel lines: **Transport Stream Data[0]** to **Transport Stream Data[7]**, along with the Transport Stream output data clock **Transport Stream Clock** (pin # 31). The frequency of the Transport Stream Data clock is 27MHz.

Transport Stream Buffer Ready (pin # 28) and **Transport Stream Data Valid** (pin # 33) are the signals to inform the user side to take over the signals.

6.2.5 Encoder Control Signals (Input and Output)

Uart_rx and **Uart_tx** are the API pins for controlling the operations of the encoder. **Uart_rx** receives the command from external control device. **Uart_tx** sends the encoder information to the control device. Refer to the **Uart** standard for details of **Uart** operations. The SOC API User Manual provides the register map for the API control. Refer to the [Encoder API User Manual](#) for more details.

An external reset **PS Soft Reset_B** (pin # 156) is available. This pin allows the user to reset the encoder when necessary. A low signal will trigger a reset. The reset signal should be maintained at high or left unconnected when in normal operation mode.

6.3 Power Rails of MCM-1000Z

Refer to Appendix-B for the pins of power and ground on the edge connector of the MCM-1000Z module. The power rails are: 1.0V, 1.2V, 1.3V, 1.5V, 2.5V, and 3.3V.

7. The H.264 4K Decoder Modules

7.1 Pin Assignments and Pin Voltages

The modules for H.264 4K resolution use the MCM-1000Z, Zynq-7035 (for 4k@30) or Zynq-7045 (4k@60). This section details the pin assignment and pin voltages for H.264 4K decoder modules based on the MCM-1000Z hardware.

Table-8 shows the pin assignments and the pin voltages for H.264 4k decoder modules based on the MCM-1000Z.

The schematics of MCM-1000Z edge connector are attached in Appendix-C of this document. Appendix-C shows the pin numbers for data, clock, control, and power, which are connected to the FPGA (Zynq-7035 or 7045, which are pin-compatible).

It should be noted that the 4K encoder and decoder pin assignments are symmetrical, i.e. the video input pins on the encoder module become the video output pins on the decoder module.

Table-8: 4K Decoder Module (based on MCM-1000Z) Pin Assignment

Description	MCM-1000Z Edge Connector Pin #	Direction	FPGA Pin #	Voltage	IO Standard
PS Soft Reset_B	156	Input	B19	3.3V	LVC MOS33
Video Clock	105	Output	AG21	3.3v	LVC MOS33
Video Horizontal Sync	133	Output	W24	1.5v	LVC MOS15
Video Vertical Sync	113	Output	AF22	3.3v	LVC MOS33
Video Display Enable	67	Output	AD18	1.5v	LVC MOS15
Video Data 0 Luma[0]	135	Output	W25	1.5v	LVC MOS15
Video Data 0 Luma[1]	137	Output	W26	1.5v	LVC MOS15
Video Data 0 Luma[2]	116	Output	V27	1.5v	LVC MOS15
Video Data 0 Luma[3]	118	Output	W28	1.5v	LVC MOS15
Video Data 0 Luma[4]	124	Output	W29	1.5v	LVC MOS15
Video Data 0 Luma[5]	126	Output	W30	1.5v	LVC MOS15
Video Data 0 Luma[6]	128	Output	V28	1.5v	LVC MOS15
Video Data 0 Luma[7]	130	Output	V29	1.5v	LVC MOS15
Video Data 0 Luma[8]	132	Output	T30	1.5v	LVC MOS15
Video Data 0 Luma[9]	134	Output	U30	1.5v	LVC MOS15
Video Data 1 Luma[0]	117	Output	AG22	3.3v	LVC MOS33
Video Data 1 Luma[1]	119	Output	AH22	3.3v	LVC MOS33
Video Data 1 Luma[2]	121	Output	AJ21	3.3v	LVC MOS33
Video Data 1 Luma[3]	123	Output	AK21	3.3v	LVC MOS33
Video Data 1 Luma[4]	125	Output	AF23	3.3v	LVC MOS33
Video Data 1 Luma[5]	127	Output	AF24	3.3v	LVC MOS33
Video Data 1 Luma[6]	92	Output	AJ23	3.3v	LVC MOS33
Video Data 1 Luma[7]	94	Output	AJ24	3.3v	LVC MOS33

Video Data 2 Chroma[1]	40	Output	AF12	3.3v	LVC MOS33
Video Data 2 Chroma[2]	50	Output	AG12	3.3v	LVC MOS33
Video Data 2 Chroma[3]	52	Output	AH12	3.3v	LVC MOS33
Video Data 2 Chroma[4]	54	Output	AH14	3.3v	LVC MOS33
Video Data 2 Chroma[5]	56	Output	AH13	3.3v	LVC MOS33
Video Data 2 Chroma[6]	58	Output	AJ14	3.3v	LVC MOS33
Video Data 2 Chroma[7]	60	Output	AJ13	3.3v	LVC MOS33
Video Data 2 Chroma[8]	59	Output	AK13	3.3v	LVC MOS33
Video Data 2 Chroma[9]	61	Output	AK12	3.3v	LVC MOS33
Video Data 3 Chroma[0]	108	Output	AJ26	3.3v	LVC MOS33
Video Data 3 Chroma[1]	110	Output	AK26	3.3v	LVC MOS33
Video Data 3 Chroma[2]	112	Output	AH26	3.3v	LVC MOS33
Video Data 3 Chroma[3]	114	Output	AH27	3.3v	LVC MOS33
Video Data 3 Chroma[4]	136	Output	AK27	3.3v	LVC MOS33
Video Data 3 Chroma[5]	138	Output	AK28	3.3v	LVC MOS33
Video Data 3 Chroma[6]	139	Output	AJ28	3.3v	LVC MOS33
Video Data 3 Chroma[7]	141	Output	AJ29	3.3v	LVC MOS33
Video Data 3 Chroma[8]	140	Output	AJ30	3.3v	LVC MOS33
Video Data 3 Chroma[9]	142	Output	AK30	3.3v	LVC MOS33
SPDIF Audio	27	Output	Y20	1.5v	LVC MOS15
Transport Stream Clock	31	Input	AA18	1.5v	LVC MOS15
Transport Stream Data Valid	33	input	AA19	1.5v	LVC MOS15
Transport Stream Data [0]	152	input	AF30	3.3v	LVC MOS33
Transport Stream Data [1]	154	input	AG30	3.3v	LVC MOS33
Transport Stream Data [2]	158	input	AE30	3.3v	LVC MOS33
Transport Stream Data [3]	160	input	AB29	3.3v	LVC MOS33
Transport Stream Data [4]	162	input	AB30	3.3v	LVC MOS33
Transport Stream Data [5]	164	input	AA27	3.3v	LVC MOS33
Transport Stream Data [6]	166	input	AA28	3.3v	LVC MOS33
Transport Stream Data [7]	120	input	AH28	3.3v	LVC MOS33
Uart_tx	90	Output	AK15	3.3v	LVC MOS33
Uart_rx	88	Input	AJ15	3.3v	LVC MOS33
Video Frame Sync Clock	80	Input	AF15	3.3v	LVC MOS33
Video Frame Sync Pause	63	Input	AC18	1.5v	LVC MOS15

7.2 Signal Formats

7.2.1 Video Clock Signal (Output)

The **Video Clock** signal (pin # 105) is the clock signal that provides the timing for the parallel luma, chroma, as well as the **Video Horizontal Sync** and **Video Vertical Sync** signals. The default is 148.5MHz for 4K@60 and 74.25MHz for 4K@30.

7.2.2 Video Data Signals (Output)

The output of the H.264 4k decoder module is the decoded video data in YUV format (4:2:2 or 4:2:0), with 40 output lines: **Video Data 0 Luma[0]** to **Video Data 3 Luma[9]**, for Luma. And, 40 lines: **Video Data 0 Chroma[0]** to **Video Data 3 Chroma[9]**, for the Chroma. The precision can be either 8-bit precision or 10-bit precision. For 8-bit precision, the Most Significant Bits of luma and chroma output lines (Luma[2] to Luma[9], Chroma[2] to Chroma[9]) are used.

In addition to the video Luma and Chroma data signals, the **Video Horizontal Sync** and **Video Vertical Sync** signals are provided for frame synchronization. The **Video Display Enable** signal is a part of the **Video Horizontal Sync** and **Video Vertical Sync** system, where high signal indicates active video pixels.

7.2.3 Audio Data Signals (Output)

Line **SPDIF Audio** is for PCM audio output, in **SPDIF** frames. An **SPDIF** transmitter is included in the module to send the PCM data out via the decoder edge pins. Refer to the **SPDIF** protocol documents for details.

7.2.4 Decoder Control Signals (Input and output)

Uart_rx and **Uart_tx** are the API pins for controlling the operations of the decoder. **Uart_rx** receives the command from external control device. **Uart_tx** send the decoder information to the control device. Refer to the **Uart** standard for details of **Uart** operations. The SOC API User Manual provides the register map for the API control. Refer to the [Decoder API User Manual](#) for details.

7.3 Power Rails of MCM-1000Z

The power rails for H.264 4K decoder for 4k@30 or 4k@60 are the same and are also the same as the H.264 4k encoder. Refer to Appendix-C for the pins of power and ground on the edge connector of the MCM-1000Z module.

7.4 Power Requirement and Supply Amperage

The total power, at operation, required by a given encoder module ranges from 3 to 5 watts, depending on the resolution and frame rate. Since the total power is delivered over 6 power rails (1.0v, 1.2v, 1.3v, 1.5v, 2.5v, and 3.3v), each individual power rails deliveries only a portion of the total power. However, the power is not evenly distributed among the rails. Table-10 lists the power estimation by Xilinx Vivado FPGA software for each rail, at 4k@60 resolution, and can be used for PCB design. It should be noted that the power rails 1.8v and 2.0v are generated on the module using the input power rails. PCB designers for the carrier boards need not to consider these two rails.

Since the decoder module normally shares the power supplies with the carrier board (user PCB). The power design should be considered for both. SOC licenses the schematics of carrier boards. The VTR-4000C, discussed in Section

6 of this document, is for 4k resolution. The reference designs not only provide the power system design, but also the I/O port designs, such as SDI, HDMI, Mini-USB, etc. Please contact SOC sale at: sales@soctechnologies.com for further details.

Table-10: Power estimation for the decoder module (4K@60 resolution)

Power Supply				
Supply Source	Voltage (V)	Total (A)	Dynamic (A)	Static (A)
Vccint	1.000	4.786	4.682	0.104
Vccaux	1.800	0.692	0.634	0.058
Vcco33	3.300	0.007	0.006	0.001
Vcco25	2.500	0.000	0.000	0.000
Vcco18	1.800	0.001	0.000	0.001
Vcco15	1.500	0.429	0.428	0.001
Vcco135	1.350	0.000	0.000	0.000
Vcco12	1.200	0.000	0.000	0.000
Vccaux_io	2.000	0.109	0.109	0.000
Vccbram	1.000	0.093	0.074	0.019
MGTAVcc	1.000	0.000	0.000	0.000
MGTAVtt	1.200	0.000	0.000	0.000
MGTVccaux	1.800	0.000	0.000	0.000
Vccpint	1.000	0.750	0.723	0.026
Vccpaux	1.800	0.061	0.051	0.010
Vccpll	1.800	0.019	0.016	0.003
Vcco_ddr	1.500	0.459	0.457	0.002
Vcco_mio0	1.800	0.007	0.006	0.001
Vcco_mio1	1.800	0.001	0.000	0.001
Vccadc	1.800	0.022	0.002	0.020

12. Carrier Board PCB Reference Designs

SOC has several evaluation boards for evaluating the standard encoder and decoder modules (and for evaluating the IP cores as well). These evaluation boards provide not only the DDR3 SODIMM connectors for connecting the encoder (and/or decoder) modules, but also the commonly used digital video/audio ports, such as SDI and HDMI. Ethernet port of tri-speed, 10/100/1000Mbps, as a network connection, is used in all of the SOC evaluation boards.

12.1 VTR-S1000 Evaluation Board

Fig. 11 shows a photo of the VTR-S1000 board. Major components and I/O ports are marked in the figure. Refer to the [User Guide of VTR -S1000](#) for further details.

SOC licenses the Schematics of VTR-S1000 to the customers that have purchased the eval kit VTR-S1000 and encoder (or decoder) Modules. Firmware of the VTR-S1000, including I/O drivers and network IP core, is also available for licensing. Please contact SOC sales, sales@soctechnologies.com, for details.

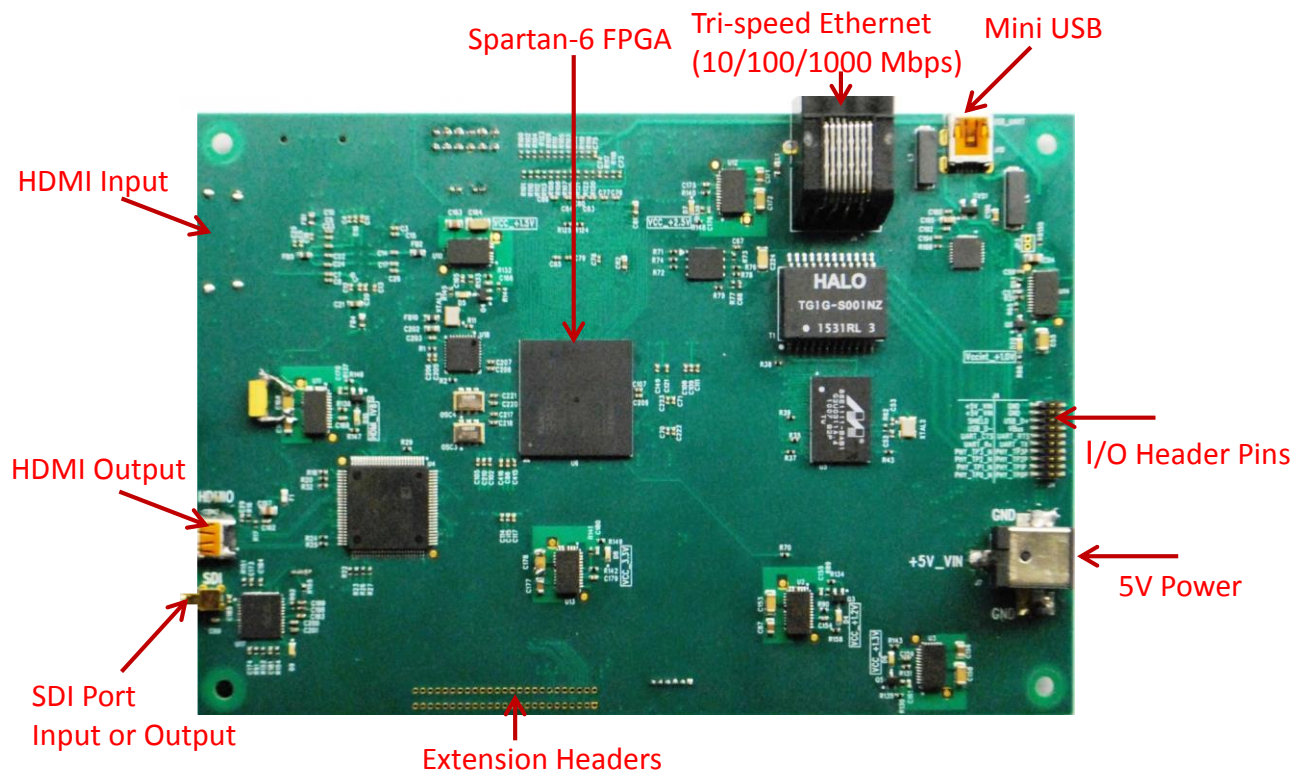

Fig. 11. FMC-MCM-1000 evaluation board

15. Document Revisions

Version #	Revision Date	Notes
V.1.0	10/05/2017	First release
V.1.1	19/05/2017	Minor revision
V.2.0	20/05/2017	Major revision (adding 4k)
V.2.1	05/06/2017	Minor revision

Appendix-A Factory Standard Codec Modules

A.1 H.265 Encoder Modules

The H.265 encoder modules are based on either the MCM-1000SX or MCM-1000Z hardware. The SOC H.265 encoder IP cores of different configurations are used to configure the FPGAs on the hardware modules to produce the codec modules.

Table-A1 lists the product codes of the factory standard H.265 video encoder (video only) modules, along with the specifications for each module. Table-A2 lists the video/audio encoder modules. The hardware platform, MCM-1000SX or MCM-1000Z, is used for the H.265 video encoder. Customers can order the H.265 encoder modules using the product code, according to the specifications required by the application.

Table-A1: H.265 Video Encoder Modules (video only without audio):

Product #	Specifications						
	Standard	Profile	Resolution	Chroma	Precision	Frame Rate	Audio
EC-V-H265-8b-30-1080-M	H.265	Main 4:2:2 12	up to 1080i/p	4:2:0/4:2:2	8 bits	up to 30fps	no
EC-V-H265-10b-30-1080-M	H.265	Main 4:2:2 12	up to 1080i/p	4:2:0/4:2:2	up to 10 bits	up to 30fps	no
EC-V-H265-10b-30-1080-M	H.265	Main 4:2:2 12	up to 1080i/p	4:2:0/4:2:2	up to 12 bits	up to 30fps	no
EC-V-H265-8b-60-1080-M	H.265	Main 4:2:2 12	up to 1080i/p	4:2:0/4:2:2	8 bits	up to 60fps	no
EC-V-H265-10b-60-1080-M	H.265	Main 4:2:2 12	up to 1080i/p	4:2:0/4:2:2	up to 10 bits	up to 60fps	no
EC-V-H265-10b-60-1080-M	H.265	Main 4:2:2 12	up to 1080i/p	4:2:0/4:2:2	up to 12 bits	up to 60fps	no
EC-V-H265-8b-30-4k-M	H.265	Main 4:2:2 12	4k/UHD	4:2:0/4:2:2	8 bits	up to 30fps	no
EC-V-H265-10b-30-4k-M	H.265	Main 4:2:2 12	4k/UHD	4:2:0/4:2:2	up to 10 bits	up to 30fps	no
EC-V-H265-10b-30-4k-M	H.265	Main 4:2:2 12	4k/UHD	4:2:0/4:2:2	up to 12 bits	up to 30fps	no
EC-V-H265-8b-60-4k-M	H.265	Main 4:2:2 12	4k/UHD	4:2:0/4:2:2	8 bits	up to 60fps	no
EC-V-H265-10b-60-4k-M	H.265	Main 4:2:2 12	4k/UHD	4:2:0/4:2:2	up to 10 bits	up to 60fps	no
EC-V-H265-10b-60-4k-M	H.265	Main 4:2:2 12	4k/UHD	4:2:0/4:2:2	up to 12bits	up to 60fps	no

Table-A4: H.264 Video&Audio Encoder Modules (both video and audio):

Product #	Specifications							Hardware
	Standard	Profile	Resolution	Chroma	Precision	Frame Rate	Audio	
EC-VA-H264-8b-30-720-MS	H.264	up to High	up to 720i/p	4:2:0/4:2:2	8 bits	up to 30fps	AAC/MPEG2 L-2	MCM-1000A
EC-VA-H264-8b-60-720-MS	H.264	up to High	up to 720i/p	4:2:0/4:2:2	8 bits	up to 60fps	AAC/MPEG2 L-2	MCM-1000A
EC-VA-H264-8b-30-1080-MS	H.264	up to High	up to 1080i/p	4:2:0/4:2:2	8 bits	up to 30fps	AAC/MPEG2 L-2	MCM-1000A
EC-VA-H264-10b-30-1080-MS	H.264	up to High	up to 1080i/p	4:2:0/4:2:2	up to 10bits	up to 30fps	AAC/MPEG2 L-2	MCM-1000A
EC-VA-H264-8b-60-1080-MA	H.264	up to High	up to 1080i/p	4:2:0/4:2:2	8 bits	up to 60fps	AAC/MPEG2 L-2	MCM-1000A
EC-VA-H264-10b-60-1080-MA	H.264	up to High	up to 1080i/p	4:2:0/4:2:2	up to 10 bits	up to 60fps	AAC/MPEG2 L-2	MCM-1000A
EC-VA-H264-8b-30-4k-MZ	H.264	High	4kx2k	4:2:0/4:2:2	8 bits	up to 30fps	AAC/MPEG2 L-2	MCM-1000Z
EC-VA-H264-10b-30-4k-MZ	H.264	High	4kx2k	4:2:0/4:2:2	10 bits	up to 30fps	AAC/MPEG2 L-2	MCM-1000Z
EC-VA-H264-8b-60-4k-MZ	H.264	High	4kx2k	4:2:0/4:2:2	8 bits	up to 60fps	AAC/MPEG2 L-2	MCM-1000Z
EC-VA-H264-10b-60-4k-MZ	H.264	High	4kx2k	4:2:0/4:2:2	10 bits	up to 60fps	AAC/MPEG2 L-2	MCM-1000Z

A.3 H.264 Decoder Modules

Hardware platform MCM-1000A is used for the H.264 HD decoders. Table-A5 lists the factory standard H.264 video decoder modules (video only), along with the product code and specifications. Table-A6 lists the factory standard H.264 video and audio decoder modules, product code, specifications.

Table-A5: H.264 Video Decoder Modules (video only without audio):

Product #	Specifications							Hardware
	Standard	Profile	Resolution	Chroma	Precision	Frame Rate	Audio	
DC-V-H264-8b-30-720-MA	H.264	up to High	up to 720i/p	4:2:0/4:2:2	8 bits	up to 30fps	no	MCM-1000A
DC-V-H264-8b-60-720-MA	H.264	up to High	up to 720i/p	4:2:0/4:2:2	8 bits	up to 60fps	no	MCM-1000A
DC-V-H264-8b-30-1080-MA	H.264	up to High	up to 1080i/p	4:2:0/4:2:2	8 bits	up to 30fps	no	MCM-1000A
DC-V-H264-10b-30-1080-MA	H.264	up to High	up to 1080i/p	4:2:0/4:2:2	up to 10 bits	up to 30fps	no	MCM-1000A
DC-V-H264-8b-60-1080-MA	H.264	up to High	up to 1080i/p	4:2:0/4:2:2	8 bits	up to 60fps	no	MCM-1000A
DC-V-H264-10b-60-1080-MA	H.264	up to High	up to 1080i/p	4:2:0/4:2:2	up to 10 bits	up to 60fps	no	MCM-1000A
DC-V-H264-8b-30-4k-MZ	H.264	High	4kx2k	4:2:0/4:2:2	8 bits	up to 30fps	no	MCM-1000Z
DC-V-H264-10b-30-4k-MZ	H.264	High	4kx2k	4:2:0/4:2:2	10 bits	up to 30fps	no	MCM-1000Z
DC-V-H264-8b-60-4k-MZ	H.264	High	4kx2k	4:2:0/4:2:2	8 bits	up to 60fps	no	MCM-1000Z
DC-V-H264-10b-60-4k-MZ	H.264	High	4kx2k	4:2:0/4:2:2	10 bits	up to 60fps	no	MCM-1000Z

Table-A6: H.264 Video&Audio Decoder Modules (both video and audio):

Product #	Specifications							Hardware
	Standard	Profile	Resolution	Chroma	Precision	Frame Rate	Audio	
DC-VA-H264-8b-30-720-MA	H.264	up to High	up to 720i/p	4:2:0/4:2:2	8 bits	up to 30fps	AAC/MPEG2 L-2	MCM-1000A
DC-VA-H264-8b-60-720-MA	H.264	up to High	up to 720i/p	4:2:0/4:2:2	8 bits	up to 60fps	AAC/MPEG2 L-2	MCM-1000A
DC-VA-H264-8b-30-1080-MA	H.264	up to High	up to 1080i/p	4:2:0/4:2:2	8 bits	up to 30fps	AAC/MPEG2 L-2	MCM-1000A
DC-VA-H264-10b-30-1080-MA	H.264	up to High	up to 1080i/p	4:2:0/4:2:2	up to 10 bits	up to 30fps	AAC/MPEG2 L-2	MCM-1000A
DC-VA-H264-8b-60-1080-MA	H.264	up to High	up to 1080i/p	4:2:0/4:2:2	8 bits	up to 60fps	AAC/MPEG2 L-2	MCM-1000A
DC-VA-H264-10b-60-1080-MA	H.264	up to High	up to 1080i/p	4:2:0/4:2:2	up to 10 bits	up to 60fps	AAC/MPEG2 L-2	MCM-1000A
DC-VA-H264-8b-30-4k-MZ	H.264	High	4kx2k	4:2:0/4:2:2	8 bits	up to 30fps	AAC/MPEG2 L-2	MCM-1000Z
DC-VA-H264-10b-30-4k-MZ	H.264	High	4kx2k	4:2:0/4:2:2	10 bits	up to 30fps	AAC/MPEG2 L-2	MCM-1000Z
DC-VA-H264-8b-60-4k-MZ	H.264	High	4kx2k	4:2:0/4:2:2	8 bits	up to 60fps	AAC/MPEG2 L-2	MCM-1000Z
DC-VA-H264-10b-60-4k-MZ	H.264	High	4kx2k	4:2:0/4:2:2	10 bits	up to 60fps	AAC/MPEG2 L-2 L	MCM-1000Z

A.4 MPEG-2 Encoder Modules

Table-A7 lists the standard MPEG-2 video encoder modules. Table-A8 lists the MPEG-2 video/audio encoder modules. The 8-bit precision and 60 frames/second modules are offered as extensions of the MPEG-2 standard.

Table-A7: MPEG-2 Video Encoder Module (video only without audio):

Product #	Specifications							Hardware
	Standard	Profile	Resolution	Chroma	Precision	Frame Rate	Audio	
EC-V-MPEG2-8b-30-720-MA	MPEG-2	up to High	up to 720i/p	4:2:0/4:2:2	8 bits	up to 30fps	no	MCM-1000A
EC-V-MPEG2-8b-60-720-MA	MPEG-2	up to High	up to 720i/p	4:2:0/4:2:2	8 bits	up to 60fps	no	MCM-1000A
EC-V-MPEG2-8b-30-1080-MA	MPEG-2	up to High	up to 1080i/p	4:2:0/4:2:2	8 bits	up to 30fps	no	MCM-1000A
EC-V-MPEG2-8b-60-1080-MA	MPEG-2	up to High	up to 1080i/p	4:2:0/4:2:2	8 bits	up to 60fps	no	MCM-1000A

Table-A8: MPEG-2 Video&Audio Encoder Modules (both video and audio):

Product #	Specifications							Hardware
	Standard	Profile	Resolution	Chroma	Precision	Frame Rate	Audio	
EC-VA-MPEG2-8b-30-720-MA	MPEG-2	up to High	up to 720i/p	4:2:0/4:2:2	8 bits	up to 30fps	AAC/MPEG2 L-2	MCM-1000A
EC-VA-MPEG2-8b-60-720-MA	MPEG-2	up to High	up to 720i/p	4:2:0/4:2:2	8 bits	up to 60fps	AAC/MPEG2 L-2	MCM-1000A
EC-VA-MPEG2-8b-30-1080-MA	MPEG-2	up to High	up to 1080i/p	4:2:0/4:2:2	8 bits	up to 30fps	AAC/MPEG2 L-2	MCM-1000A
EC-VA-MPEG2-8b-60-1080-MA	MPEG-2	up to High	up to 1080i/p	4:2:0/4:2:2	8 bits	up to 60fps	AAC/MPEG2 L-2	MCM-1000A

Table-A12: H.264-to-H.265 Video & Audio Transcoder Modules (both video and audio):

Product #	Specifications							Hardware
	Standard	Profile	Resolution	Chroma	Precision	Frame Rate	Audio	
TC-V-H.264-to-H.265-8b-30-720-MZ	H.265	Main 4:2:2	up to 720i/p	up to 4:2:2	8 bits	up to 30fps	AAC/MPEG2 L-2	MCM-1000Z
TC-V-H.264-to-H.265-10b-30-720-MZ	H.265	Main 4:2:2	up to 720i/p	up to 4:2:2	10 bits	up to 30fps	AAC/MPEG2 L-2	MCM-1000Z
TC-V- H.264-to-H.265-8b-60-720-MZ	H.265	Main 4:2:2	up to 720i/p	up to 4:2:2	8 bits	up to 60fps	AAC/MPEG2 L-2	MCM-1000Z
TC-V- H.264-to-H.265-10b-60-720-MZ	H.265	Main 4:2:2	up to 720i/p	up to 4:2:2	10 bits	up to 60fps	AAC/MPEG2 L-2	MCM-1000Z
TC-V- H.264-to-H.265-8b-30-1080-MZ	H.265	Main 4:2:2	up to 1080i/p	up to 4:2:2	8 bits	up to 30fps	AAC/MPEG2 L-2	MCM-1000Z
TC-V- H.264-to-H.265-10b-30-1080-MZ	H.265	Main 4:2:2	up to 1080i/p	up to 4:2:2	10 bits	up to 30fps	AAC/MPEG2 L-2	MCM-1000Z
TC-V- H.264-to-H.265-8b-60-1080-MZ	H.265	Main 4:2:2	up to 1080i/p	up to 4:2:2	8 bits	up to 60fps	AAC/MPEG2 L-2	MCM-1000Z
TC-V- H.264-to-H.265-10b-60-1080-MZ	H.265	Main 4:2:2	up to 1080i/p	up to 4:2:2	10 bits	up to 60fps	AAC/MPEG2 L-2	MCM-1000Z

A.7 H.264-to-MPEG2 Transcoder Modules

Table-A13 lists the standard H.264-to-MPEG2 video transcoder modules. Table-A14 lists the H.264-to-MPEG2 video/audio transcoder modules. The 60frames/second modules are offered as extensions of MPEG-2 standard.

Table-A13: H.264-to-MPEG2 Video Transcoder Modules (video only without audio):

Product #	Specifications							Hardware
	Standard	Profile	Resolution	Chroma	Precision	Frame Rate	Audio	
TC-V-H.264-to-MPEG2-8b-30-720-MZ	MPEG2	High	up to 720i/p	up to 4:2:2	8 bits	up to 30fps	no	MCM-1000Z
TC-V- H.264-to-MPEG2-8b-60-720-MZ	MPEG2	High	up to 720i/p	up to 4:2:2	8 bits	up to 60fps	no	MCM-1000Z
TC-V- H.264-to-MPEG2-8b-30-1080-MZ	MPEG2	High	up to 1080i/p	up to 4:2:2	8 bits	up to 30fps	no	MCM-1000Z
TC-V- H.264-to-MPEG2-8b-60-1080-MZ	MPEG2	High	up to 1080i/p	up to 4:2:2	8 bits	up to 60fps	no	MCM-1000Z

Table-A14: H.264-to-MPEG2 Video&Audio Transcoder Modules (both video and audio):

Product #	Specifications							Hardware
	Standard	Profile	Resolution	Chroma	Precision	Frame Rate	Audio	
TC-VA- H.264-to -MPEG2-8b-30-720-MZ	MPEG2	High	up to 720i/p	up to 4:2:2	8 bits	up to 30fps	AAC/MPEG2-L2	MCM-1000Z
TC-VA- H.264-to -MPEG2-8b-60-720-MZ	MPEG2	High	up to 720i/p	up to 4:2:2	8 bits	up to 60fps	AAC/MPEG2-L2	MCM-1000Z
TC-VA- H.264-to -MPEG2-8b-30-1080-MZ	MPEG2	High	up to 1080i/p	up to 4:2:2	8 bits	up to 30fps	AAC/MPEG2-L2	MCM-1000Z
TC-VA- H.264-to -MPEG2-8b-60-1080-MZ	MPEG2	High	up to 1080i/p	up to 4:2:2	8 bits	up to 60fps	AAC/MPEG2-L2	MCM-1000Z

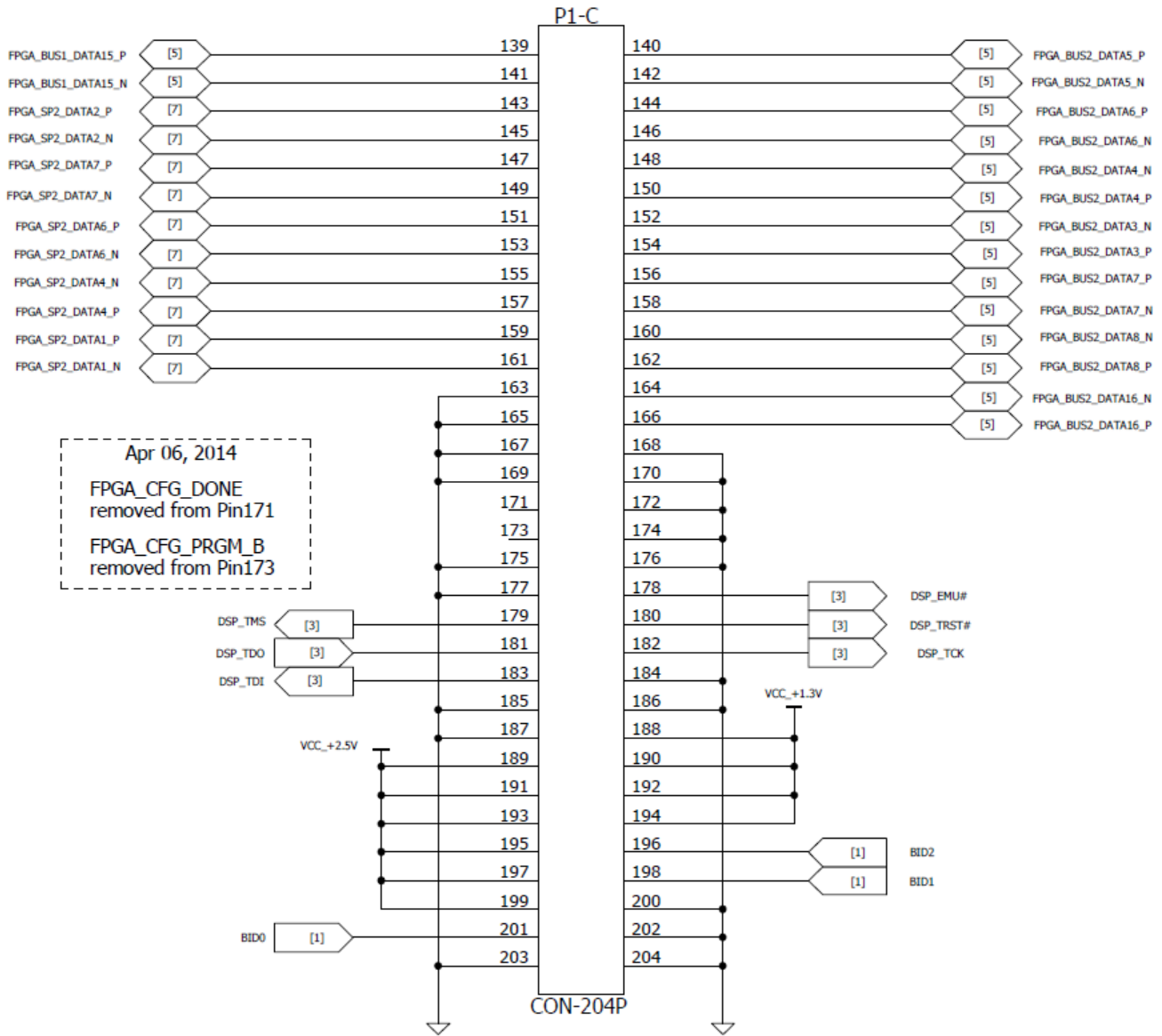

Appendix - C MCM-1000Z Edge Connector Schematics

