



Welcome to E-XFL.COM

Understanding [Embedded - Microcontroller, Microprocessor, FPGA Modules](#)

Embedded - Microcontroller, Microprocessor, and FPGA Modules are fundamental components in modern electronic systems, offering a wide range of functionalities and capabilities. Microcontrollers are compact integrated circuits designed to execute specific control tasks within an embedded system. They typically include a processor, memory, and input/output peripherals on a single chip. Microprocessors, on the other hand, are more powerful processing units used in complex computing tasks, often requiring external memory and peripherals. FPGAs (Field Programmable Gate Arrays) are highly flexible devices that can be configured by the user to perform specific logic functions, making them invaluable in applications requiring customization and adaptability.

Applications of [Embedded - Microcontroller,](#)

Details

Product Status	Discontinued at Digi-Key
Module/Board Type	FPGA Core
Core Processor	Artix-7 A200T
Co-Processor	-
Speed	-
Flash Size	32MB
RAM Size	256KB
Connector Type	SO-DIMM-204
Size / Dimension	2.7" x 2.0" (68mm x 51mm)
Operating Temperature	0°C ~ 85°C
Purchase URL	https://www.e-xfl.com/product-detail/soc-technologies/dc-va-h264-8b-30-1080-mxc-zl

9. The H.265 HD Decoder Modules

- 9.1 Pin Assignments and Pin Voltages**
- 9.2 Signal Formats**
 - 9.2.1 Clock Signal (Input)**
 - 9.2.2 Video Data Signals (Output)**
 - 9.2.3 Audio Data Signals (Output)**
 - 9.2.4 TS Signals (Input)**
 - 9.2.5 Encoder Control Signals (Input and Output)**
- 9.3 Power Rails of MCM-1000SX**
- 9.4 Power Requirement and Supply Amperage**

10. The H.265 4K Encoder Modules

- 10.1 Pin Assignments and Pin Voltages**
- 10.2 Signal Formats**
 - 10.2.1 Clock Signals (Input, Output)**
 - 10.2.2 Video Data Signals (Input)**
 - 10.2.3 Audio Data Signals (Input)**
 - 10.2.4 TS Signals (Output)**
 - 10.2.5 Decoder Control Signals (Input and Output)**
- 10.3 Power Rails of MCM-1000SX**
- 10.4 Power Requirement and Supply Amperage**

11. The H.265 4K Decoder Modules

- 11.1 Pin Assignments and Pin Voltages**
- 11.2 Signal Formats**
 - 11.2.1 Clock Signals (Input, Output)**
 - 11.2.2 Video Data Signals (Output)**
 - 11.2.3 Audio Data Signals (Output)**
 - 11.2.4 TS Signals (Input)**
 - 11.2.5 Decoder Control Signals (Input and Output)**
- 11.3 Power Rails of MCM-1000SX**
- 11.4 Power Requirement and Supply Amperage**

12. Carrier Board References

12.1 VTR-S1000 Board

12.2 VTR-4000C Board

13. Ordering Information

14. Contact Information

15. Document Versions

Appendix-A SOC Standard Codec Modules

Appendix-B MCM-1000A Edge Connector Schematics

Appendix-C MCM-1000Z Edge Connector Schematics

1. Overview of SOC SOM Modules

The SOC SOMs are small circuit boards with FPGA, DDRs, Flash, and clocks in one module to support FPGA-based systems. A module can be configured into a SOM by using the applicable firmware. The module is connected to a user PCB through a standard DDR3 SODIMM connector. Customers can order the blank SOMs from SOC and use their own firmware to make SOM products.

SOC configures the modules into MPEG codec SOMs for video/audio compression, decompression, and transcoding functions. Currently available modules are:

	Hardware Product Code	FPGA Chip on the Module	SOC Codec module Resolution Capacity
1	MCM-1000S	Spartan-6 XC6SLX150	H.264 or MPEG-2 HD up to 1080@30
2	MCM-1000A	Artix-7 XC7A200T	H.264 or MPEG-2 HD up to 1080@60
3	MCM-1000Z	Zynq-7 XC7Z035/045	H.264 4k@30/60, or H.265 HD up to 1080@60
4	MCM-1000SX	Arria-10 SX220/270/320/480/570/660	H.264 HD 1080@30/60, or H.264 4k@30/60, or H.265 HD up to 1080@60), or H.265 4k@30/60

Fig. 1 shows a photo of the modules. Fig. 2-5 shows the dimensions of MCM-1000S, MCM-1000A, MCM-1000Z, and MCM-1000SX respectively.



Fig. 1 SOC codec modules

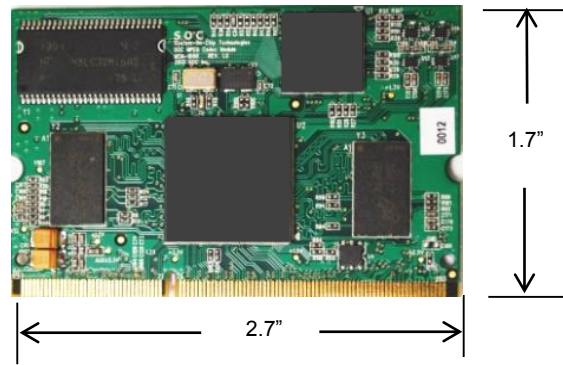

Fig. 2. Dimension of MCM-1000S

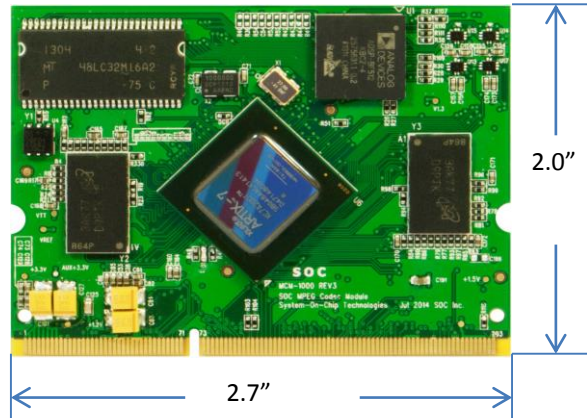

Fig. 3. Dimension of MCM-1000A

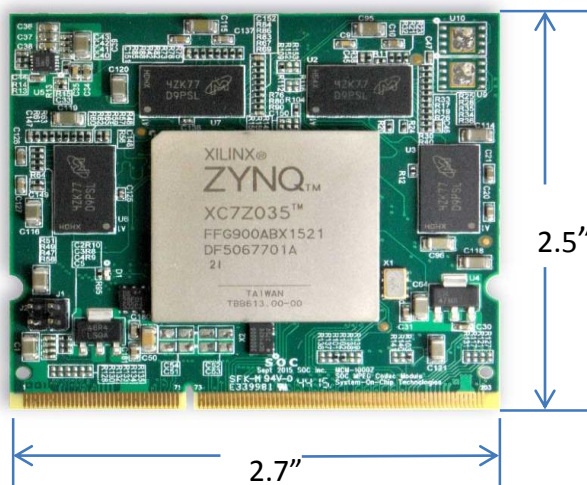

Fig. 4. Dimension of MCM-1000Z

Transport Stream Buffer Ready	112	Input	AA20	3.3v	LVC MOS33
Transport Stream Clock	93	Output	Y18	3.3v	LVC MOS33
Transport Stream Data Valid	106	Output	R17	3.3v	LVC MOS33
Transport Stream Data[0]	77	Output	N13	3.3v	LVC MOS33
Transport Stream Data[1]	79	Output	N14	3.3v	LVC MOS33
Transport Stream Data[2]	81	Output	R18	3.3v	LVC MOS33
Transport Stream Data[3]	83	Output	T18	3.3v	LVC MOS33
Transport Stream Data[4]	85	Output	U17	3.3v	LVC MOS33
Transport Stream Data[5]	87	Output	U18	3.3v	LVC MOS33
Transport Stream Data[6]	89	Output	AB18	3.3v	LVC MOS33
Transport Stream Data[7]	91	Output	AA18	3.3v	LVC MOS33
Transport Stream Start Code	40	Output	V19	3.3v	LVC MOS33
Uart_tx	90	Output	AA16	3.3v	LVC MOS33
Uart_rx	88	Input	Y16	3.3v	LVC MOS33

4.2 Signal Formats

4.2.1 Video Clock Signal (Input)

The **Video Clock** signal (pin # 105) has two functions: (1) It is the clock for the input video data, and (2) it is the clock that drives the encoder engine.

The **Video Clock** signal usually comes from the video input interface chip, such as HDMI or SDI. It is the clock for the input video data. It is also used for driving the encoder engine. The frequency varies according to the resolution of the video input. The following are the clock frequencies for standard video resolutions.

1. 27MHz, for SD resolution
2. 74.25MHz, for 720@60 and 1080@30
3. 148.5MHz, for 1080@60

4.2.2 Video Data Signals (Input)

The input to the encoder module (H.264 or MPEG-2) is raw video data in YUV format (4:2:2 or 4:2:0), with 10 input lines: **Video Data Luma[0]** to **Video Data Luma[9]**, for Luma. And, 10 input lines: **Video Data Chroma[0]** to **Video Data Chroma[9]**, for the Chroma. The precision can be either 8-bit or 10-bit. When 8-bit precision is used, **Video Data Luma[0]**, **Video Data Luma[1]**, **Video Data Chroma[0]**, and **Video Data Chroma[1]** are zeros.

In addition to the video Luma and Chroma data signals, the **Video Horizontal Sync** and **Video Vertical Sync** signals are required for frame synchronization. A **Video Clock** (refer to Section 4.2.1 for the clock frequencies) is required, which provides the timing for the parallel input of luma, chroma, as well as for the **Video Horizontal Sync** and **Video Vertical Sync** signals. The **Video Display Enable** signal (pin #150) is a part of the **Video Horizontal Sync** and **Video Vertical Sync** system, where high signal indicates active video pixels. For example, an HDMI input interface chip will output the **Display Enable signal** at high, when active pixels are being sent out.

The video data are sampled at the rising edge of the clock. The clock rates will correspond to the resolution and frame rate, as discussed in Section 4.2.1.

4.4 Power Requirement and Supply Amperage

The total power, at operation, required by a given encoder module ranges from 2 to 5 watts, depending on the resolution and frame rate. Since the total power is delivered over 6 power rails, each individual power rail deliveries only a portion of the total power. However, the power is not evenly distributed among the rails. Table-3 lists the power estimation by Xilinx Vivado FPGA software for each rail, at 1080p@60 resolution, which can be used as a reference for PCB design. It should be noted that the measured real power consumption is about 20% lower than the estimated power consumption.

It should be noted that the power rails of 1.8v is generated on the module, using the 2.5v power input from the edge pin. PCB designers need only to design the 6 power rails listed in Table-2, as the 1.8v is generated on the module.

Table-3: Power estimation for the encoder module (1080p@60 resolution)

Power Supply				
Supply Source	Voltage (V)	Total (A)	Dynamic (A)	Static (A)
Vccint	1.000	3.792	3.723	0.069
Vccaux	1.800	0.454	0.421	0.034
Vcco33	3.300	0.013	0.008	0.005
Vcco25	2.500	0.000	0.000	0.000
Vcco18	1.800	0.000	0.000	0.000
Vcco15	1.500	0.499	0.494	0.005
Vcco135	1.350	0.000	0.000	0.000
Vcco12	1.200	0.000	0.000	0.000
Vccaux_io	1.800	0.000	0.000	0.000
Vccbram	1.000	0.063	0.052	0.011
MGTAVcc	1.000	0.000	0.000	0.000
MGTAVtt	1.200	0.000	0.000	0.000
Vccadc	1.800	0.022	0.002	0.020

Since the encoder module normally shares the power supplies with the carrier board (user PCB). The power design should be considered for both. SOC licenses the schematics of carrier boards, such as the VTR-S1000 and VTR-4000C discussed in Section 12 of this document. The reference designs provide not only the power system design, but also the I/O port designs, such as SDI, HDMI, Mini-USB, etc. Please contact SOC sale at: sales@soctechnologies.com for design licensing details.

5. The H.264 (and MPEG-2) HD Decoder Modules

5.1 Pin Assignments and Pin Voltages

The decoders for H.264 and MPEG-2 have the same pin assignment. The module for HD resolution decoding uses the MCM-1000A (with the Artix-7 A200T FPGA which is the same as the one used for the HD Encoder). The module MCM-1000Z is used for 4k decoding (the Zynq-7035 for 4k@30, Zynq-7045 for 4k@60).

This section details the pin assignments and pin voltages for the HD decoder (H.264, and MPEG-2) modules. Table-4 shows the pin assignments and the pin voltages.

The schematics of MCM-1000A edge connector are attached in Appendix-B of this document. Appendix-B shows the pin numbers for data, clock, control, and power, which are connected to the FPGA (Artix-7 XC7A200T). It should be noted that the decoder module uses only some of the available edge pins that are connected to the FPGA (some of the pins are not used).

It should also be noted that the HD encoder and decoder pin assignments are symmetrical, i.e. the video input pins on the encoder module become the video output pins on the decoder module.

Table-4: HD Decoder Module (based on MCM-1000A) Pin Assignment

Description	MCM-1000A Edge Connector Pin #	Direction	FPGA Pin #	Voltage	IO Standard
External Reset	121	Input	W21	3.3v	LVCMS33
Decoder Clock	115	Input	U20	3.3v	LVCMS33
Video Clock	105	Output	Y11	3.3v	LVCMS33
Video Horizontal Sync	146	Output	W16	3.3v	LVCMS33
Video Vertical Sync	148	Output	V15	3.3v	LVCMS33
Video Display Enable	150	Output	U15	3.3v	LVCMS33
Video Data Luma[0]	50	Output	W14	3.3v	LVCMS33
Video Data Luma[1]	52	Output	Y14	3.3v	LVCMS33
Video Data Luma[2]	58	Output	V10	3.3v	LVCMS33
Video Data Luma[3]	59	Output	Y13	3.3v	LVCMS33
Video Data Luma[4]	60	Output	W10	3.3v	LVCMS33
Video Data Luma[5]	61	Output	AA14	3.3v	LVCMS33
Video Data Luma[6]	80	Output	AB13	3.3v	LVCMS33
Video Data Luma[7]	82	Output	AA13	3.3v	LVCMS33
Video Data Luma[8]	84	Output	AB17	3.3v	LVCMS33
Video Data Luma[9]	86	Output	AB16	3.3v	LVCMS33
Video Data Chroma[0]	92	Output	AA15	3.3v	LVCMS33
Video Data Chroma[1]	94	Output	AB15	3.3v	LVCMS33
Video Data Chroma[2]	96	Output	AB12	3.3v	LVCMS33
Video Data Chroma[3]	98	Output	AB11	3.3v	LVCMS33
Video Data Chroma[4]	107	Output	Y12	3.3v	LVCMS33
Video Data Chroma[5]	108	Output	W12	3.3v	LVCMS33
Video Data Chroma[6]	110	Output	Y17	3.3v	LVCMS33
Video Data Chroma[7]	140	Output	T14	3.3v	LVCMS33
Video Data Chroma[8]	142	Output	T15	3.3v	LVCMS33
Video Data Chroma[9]	144	Output	W15	3.3v	LVCMS33
Video Frame Sync Relock	56	Input	AB21	3.3v	LVCMS33

to **Video Data Chroma[9]**, for the Chroma. The precision can be either 8-bit or 10-bit. When 8-bit precision is used, **Video Data Luma[0]**, **Video Data Luma[1]**, **Video Data Chroma[0]**, and **Video Data Chroma[1]** are zeros.

In addition to the video Luma and Chroma data signals, the **Video Horizontal Sync** and **Video Vertical Sync** signals are provided for frame synchronization. A **Video Clock** (refer to Section 5.2.1 for the clock frequencies) is sent out, which provides the timing for the parallel inputs of luma, chroma, as well as the **Video Horizontal Sync** and **Video Vertical Sync signals**. The **Video Display Enable** signal (pin #150) is a part of the **Video Horizontal Sync** and **Video Vertical Sync** system, where high signal indicates active video pixels.

Output data are sampled at the rising edge of the clock. (The clock rates will correspond to the resolution and frame rate, as discussed in Section 5.2.1.)

5.2.3 Audio Data Signals (Output)

Line **SPDIF Audio** is for PCM audio output, in **SPDIF** frames. An **SPDIF** transmitter is included in the module to send the PCM data out via the decoder edge pins. Refer to the **SPDIF** protocol documents for details.

5.2.4 TS Stream Signals (Input)

The input of the decoder module is an MPEG transport stream, which is sent into the module by 8 parallel lines: **Transport Stream Data[0]** to **Transport Stream Data[7]**. **Transport Stream Clock** (27MHz) is the clock for the **Transport Stream Data** lines. The **Transport Stream Data Valid** signal informs the decoder that the input is valid.

5.2.5 Decoder Control Signals (Input and Output)

Uart_rx and **Uart_tx** are the API pins for controlling the operations of the decoder. **Uart_rx** receives the command from external control device. **Uart_tx** send the decoder information to the control device. Refer to the **Uart** standard for details of **Uart** operations. The SOC API User Manual provides the register map for the API control. Refer to the [Decoder API User Manual](#) for details.

5.3 Power Rails of MCM-1000A

The power rails for the HD (H.264 or MPEG-2) decoder module is the same as the ones for the HD encoder module. Refer to Table-2 for the power and ground pins. Also, refer to Appendix-A for the power and ground pins on the edge connector of the MCM-1000A module.

5.4 Power Requirement and Supply Amperage

The total power at operation required by a given decoder ranges from 2 to 4 Watts, depending on the resolution and frame rate. Since the total power is delivered over 6 power rails, each individual power rail delivers only a portion of the total lower. However, the power is not evenly distributed among the rails. Table-5 lists the power

Video Data 2 Chroma[2]	50	Input	AG12	3.3v	LVC MOS33
Video Data 2 Chroma[3]	52	Input	AH12	3.3v	LVC MOS33
Video Data 2 Chroma[4]	54	Input	AH14	3.3v	LVC MOS33
Video Data 2 Chroma[5]	56	Input	AH13	3.3v	LVC MOS33
Video Data 2 Chroma[6]	58	Input	AJ14	3.3v	LVC MOS33
Video Data 2 Chroma[7]	60	Input	AJ13	3.3v	LVC MOS33
Video Data 2 Chroma[8]	59	Input	AK13	3.3v	LVC MOS33
Video Data 2 Chroma[9]	61	Input	AK12	3.3v	LVC MOS33
Video Data 3 Chroma[0]	108	Input	AJ26	3.3v	LVC MOS33
Video Data 3 Chroma[1]	110	Input	AK26	3.3v	LVC MOS33
Video Data 3 Chroma[2]	112	Input	AH26	3.3v	LVC MOS33
Video Data 3 Chroma[3]	114	Input	AH27	3.3v	LVC MOS33
Video Data 3 Chroma[4]	136	Input	AK27	3.3v	LVC MOS33
Video Data 3 Chroma[5]	138	Input	AK28	3.3v	LVC MOS33
Video Data 3 Chroma[6]	139	Input	AJ28	3.3v	LVC MOS33
Video Data 3 Chroma[7]	141	Input	AJ29	3.3v	LVC MOS33
Video Data 3 Chroma[8]	140	Input	AJ30	3.3v	LVC MOS33
Video Data 3 Chroma[9]	142	Input	AK30	3.3v	LVC MOS33
SPDIF Audio	27	Input	Y20	1.5v	LVC MOS15
Transport Stream Buffer	29	Input	AA20	1.5v	LVC MOS15
Transport Stream Clock	31	Output	AA18	1.5v	LVC MOS15
Transport Stream Data	33	Output	AA19	1.5v	LVC MOS15
Transport Stream Data [0]	152	Output	AF30	3.3v	LVC MOS33
Transport Stream Data [1]	154	Output	AG30	3.3v	LVC MOS33
Transport Stream Data [2]	158	Output	AE30	3.3v	LVC MOS33
Transport Stream Data [3]	160	Output	AB29	3.3v	LVC MOS33
Transport Stream Data [4]	162	Output	AB30	3.3v	LVC MOS33
Transport Stream Data [5]	164	Output	AA27	3.3v	LVC MOS33
Transport Stream Data [6]	166	Output	AA28	3.3v	LVC MOS33
Transport Stream Data [7]	120	Output	AH28	3.3v	LVC MOS33
Uart_tx	90	Output	AK15	3.3v	LVC MOS33
Uart_rx	88	Input	AJ15	3.3v	LVC MOS33

6.2 Signal Formats

6.2.1 Clock Signals (Input)

The 4k encoder has 4 input clocks, **Video Clock 0** (pin # 63), **Video Clock 1** (pin # 80), **Video Clock 2** (pin # 144), and **Video Clock 3** (pin # 105). These clocks match the four of 3G SDI inputs for one 4k@30/60 video. However, if one 4k input is used on the carrier board, such as HDMI 2.0 or 12G SDI, only **Video Clock 0** is needed which takes the input video clock (74.5MHz for 4k@30, and 148.5 MHz for 4k@60).

6.2.2 Video Data Signals (Input)

The input to the encoder module is raw video data in YUV format (4:2:2 or 4:2:0), with 40 input lines: **Video Data 0 Luma[0]** to **Video Data 3 Luma[9]**, for Luma. And, 40 input lines: **Video Data 0 Chroma[0]** to **Video Data 3**

Chroma[9], for the Chroma. The precision is either 8 bits or 10 bits. For 8-bit precision, the Most Significant Luma and Chroma pins (Luma[2] to Luma[9], Chroma[2] to Chroma[9]) are used.

In addition to the video Luma and Chroma data signals, the **Video Horizontal Sync** and **Video Vertical Sync** signals are required for frame synchronization if embedded SAV/EAV are not used. The video clocks (refer to Section 6.2.1) provide the timing for the parallel input of luma, chroma, as well as the **Video Horizontal Sync** and **Video Vertical Sync** signals. The **Video Display Enable** signal is a part of the **Video Horizontal Sync** and **Video Vertical Sync** system, where high signal indicates active video pixels. For example, an HDMI input interface chip will output the **Video Display Enable** signal at high, when active pixels are being sent out.

The video data are sampled at the rising edge of the clock. The clock rates will correspond to the resolution and frame rate, as discussed in Section 6.2.1.

6.2.3 Audio Data Signals (Input)

Input line **SPDIF Audio** is for PCM audio input, in **SPDIF** frames. An **SPDIF** transmitter is required to send the PCM data to the encoder module. Refer to the **SPDIF** protocol documents for details.

6.2.4 TS stream Signals (Output)

The output of the encoder module is MPEG Transport Stream (TS), which is sent out from the module by 8 parallel lines: **Transport Stream Data[0]** to **Transport Stream Data[7]**, along with the Transport Stream output data clock **Transport Stream Clock** (pin # 31). The frequency of the Transport Stream Data clock is 27MHz.

Transport Stream Buffer Ready (pin # 28) and **Transport Stream Data Valid** (pin # 33) are the signals to inform the user side to take over the signals.

6.2.5 Encoder Control Signals (Input and Output)

Uart_rx and **Uart_tx** are the API pins for controlling the operations of the encoder. **Uart_rx** receives the command from external control device. **Uart_tx** sends the encoder information to the control device. Refer to the **Uart** standard for details of **Uart** operations. The SOC API User Manual provides the register map for the API control. Refer to the [Encoder API User Manual](#) for more details.

An external reset **PS Soft Reset_B** (pin # 156) is available. This pin allows the user to reset the encoder when necessary. A low signal will trigger a reset. The reset signal should be maintained at high or left unconnected when in normal operation mode.

6.3 Power Rails of MCM-1000Z

Refer to Appendix-B for the pins of power and ground on the edge connector of the MCM-1000Z module. The power rails are: 1.0V, 1.2V, 1.3V, 1.5V, 2.5V, and 3.3V.

Video Data 1 Luma[8]	96	Output	AG24	3.3v	LVC MOS33
Video Data 1 Luma[9]	98	Output	AG25	3.3v	LVC MOS33
Video Data 2 Luma[0]	77	Output	AJ16	3.3v	LVC MOS33
Video Data 2 Luma[1]	79	Output	AK16	3.3v	LVC MOS33
Video Data 2 Luma[2]	81	Output	AH17	3.3v	LVC MOS33
Video Data 2 Luma[3]	83	Output	AH16	3.3v	LVC MOS33
Video Data 2 Luma[4]	85	Output	AH18	3.3v	LVC MOS33
Video Data 2 Luma[5]	87	Output	AJ18	3.3v	LVC MOS33
Video Data 2 Luma[6]	78	Output	AF13	3.3v	LVC MOS33
Video Data 2 Luma[7]	82	Output	AG15	3.3v	LVC MOS33
Video Data 2 Luma[8]	84	Output	AG17	3.3v	LVC MOS33
Video Data 2 Luma[9]	86	Output	AG16	3.3v	LVC MOS33
Video Data 3 Luma[0]	107	Output	AH21	3.3v	LVC MOS33
Video Data 3 Luma[1]	122	Output	AH29	3.3v	LVC MOS33
Video Data 3 Luma[2]	115	Output	AE22	3.3v	LVC MOS33
Video Data 3 Luma[3]	146	Output	AF28	3.3v	LVC MOS33
Video Data 3 Luma[4]	148	Output	AF29	3.3v	LVC MOS33
Video Data 3 Luma[5]	150	Output	AG29	3.3v	LVC MOS33
Video Data 3 Luma[6]	100	Output	AH23	3.3v	LVC MOS33
Video Data 3 Luma[7]	102	Output	AH24	3.3v	LVC MOS33
Video Data 3 Luma[8]	104	Output	AJ25	3.3v	LVC MOS33
Video Data 3 Luma[9]	106	Output	AK25	3.3v	LVC MOS33
Video Data 0 Chroma[0]	143	Output	T29	1.5v	LVC MOS15
Video Data 0 Chroma[1]	145	Output	U29	1.5v	LVC MOS15
Video Data 0 Chroma[2]	147	Output	R28	1.5v	LVC MOS15
Video Data 0 Chroma[3]	149	Output	T28	1.5v	LVC MOS15
Video Data 0 Chroma[4]	151	Output	P30	1.5v	LVC MOS15
Video Data 0 Chroma[5]	153	Output	R30	1.5v	LVC MOS15
Video Data 0 Chroma[6]	155	Output	N29	1.5v	LVC MOS15
Video Data 0 Chroma[7]	157	Output	P29	1.5v	LVC MOS15
Video Data 0 Chroma[8]	159	Output	N28	1.5v	LVC MOS15
Video Data 0 Chroma[9]	161	Output	P28	1.5v	LVC MOS15
Video Data 1 Chroma[0]	89	Output	AK17	3.3v	LVC MOS33
Video Data 1 Chroma[1]	91	Output	AK18	3.3v	LVC MOS33
Video Data 1 Chroma[2]	93	Output	AF19	3.3v	LVC MOS33
Video Data 1 Chroma[3]	95	Output	AG19	3.3v	LVC MOS33
Video Data 1 Chroma[4]	97	Output	AH19	3.3v	LVC MOS33
Video Data 1 Chroma[5]	99	Output	AJ19	3.3v	LVC MOS33
Video Data 1 Chroma[6]	101	Output	AF20	3.3v	LVC MOS33
Video Data 1 Chroma[7]	103	Output	AG20	3.3v	LVC MOS33
Video Data 1 Chroma[8]	109	Output	AJ20	3.3v	LVC MOS33
Video Data 1 Chroma[9]	111	Output	AK20	3.3v	LVC MOS33
Video Data 2 Chroma[0]	38	Output	AE12	3.3v	LVC MOS33

Video Data 2 Chroma[1]	40	Output	AF12	3.3v	LVC MOS33
Video Data 2 Chroma[2]	50	Output	AG12	3.3v	LVC MOS33
Video Data 2 Chroma[3]	52	Output	AH12	3.3v	LVC MOS33
Video Data 2 Chroma[4]	54	Output	AH14	3.3v	LVC MOS33
Video Data 2 Chroma[5]	56	Output	AH13	3.3v	LVC MOS33
Video Data 2 Chroma[6]	58	Output	AJ14	3.3v	LVC MOS33
Video Data 2 Chroma[7]	60	Output	AJ13	3.3v	LVC MOS33
Video Data 2 Chroma[8]	59	Output	AK13	3.3v	LVC MOS33
Video Data 2 Chroma[9]	61	Output	AK12	3.3v	LVC MOS33
Video Data 3 Chroma[0]	108	Output	AJ26	3.3v	LVC MOS33
Video Data 3 Chroma[1]	110	Output	AK26	3.3v	LVC MOS33
Video Data 3 Chroma[2]	112	Output	AH26	3.3v	LVC MOS33
Video Data 3 Chroma[3]	114	Output	AH27	3.3v	LVC MOS33
Video Data 3 Chroma[4]	136	Output	AK27	3.3v	LVC MOS33
Video Data 3 Chroma[5]	138	Output	AK28	3.3v	LVC MOS33
Video Data 3 Chroma[6]	139	Output	AJ28	3.3v	LVC MOS33
Video Data 3 Chroma[7]	141	Output	AJ29	3.3v	LVC MOS33
Video Data 3 Chroma[8]	140	Output	AJ30	3.3v	LVC MOS33
Video Data 3 Chroma[9]	142	Output	AK30	3.3v	LVC MOS33
SPDIF Audio	27	Output	Y20	1.5v	LVC MOS15
Transport Stream Clock	31	Input	AA18	1.5v	LVC MOS15
Transport Stream Data Valid	33	input	AA19	1.5v	LVC MOS15
Transport Stream Data [0]	152	input	AF30	3.3v	LVC MOS33
Transport Stream Data [1]	154	input	AG30	3.3v	LVC MOS33
Transport Stream Data [2]	158	input	AE30	3.3v	LVC MOS33
Transport Stream Data [3]	160	input	AB29	3.3v	LVC MOS33
Transport Stream Data [4]	162	input	AB30	3.3v	LVC MOS33
Transport Stream Data [5]	164	input	AA27	3.3v	LVC MOS33
Transport Stream Data [6]	166	input	AA28	3.3v	LVC MOS33
Transport Stream Data [7]	120	input	AH28	3.3v	LVC MOS33
Uart_tx	90	Output	AK15	3.3v	LVC MOS33
Uart_rx	88	Input	AJ15	3.3v	LVC MOS33
Video Frame Sync Clock	80	Input	AF15	3.3v	LVC MOS33
Video Frame Sync Pause	63	Input	AC18	1.5v	LVC MOS15

7.2 Signal Formats

7.2.1 Video Clock Signal (Output)

The **Video Clock** signal (pin # 105) is the clock signal that provides the timing for the parallel luma, chroma, as well as the **Video Horizontal Sync** and **Video Vertical Sync** signals. The default is 148.5MHz for 4K@60 and 74.25MHz for 4K@30.

8. The H.265 HD Encoder Modules

To be added

9. The H.265 HD Decoder Modules

To be added

10. The H.265 4k Encoder Modules

To be added

11. The H.265 4k Decoder Modules

To be added

12. Carrier Board PCB Reference Designs

SOC has several evaluation boards for evaluating the standard encoder and decoder modules (and for evaluating the IP cores as well). These evaluation boards provide not only the DDR3 SODIMM connectors for connecting the encoder (and/or decoder) modules, but also the commonly used digital video/audio ports, such as SDI and HDMI. Ethernet port of tri-speed, 10/100/1000Mbps, as a network connection, is used in all of the SOC evaluation boards.

12.1 VTR-S1000 Evaluation Board

Fig. 11 shows a photo of the VTR-S1000 board. Major components and I/O ports are marked in the figure. Refer to the [User Guide of VTR -S1000](#) for further details.

SOC licenses the Schematics of VTR-S1000 to the customers that have purchased the eval kit VTR-S1000 and encoder (or decoder) Modules. Firmware of the VTR-S1000, including I/O drivers and network IP core, is also available for licensing. Please contact SOC sales, sales@soctechnologies.com, for details.

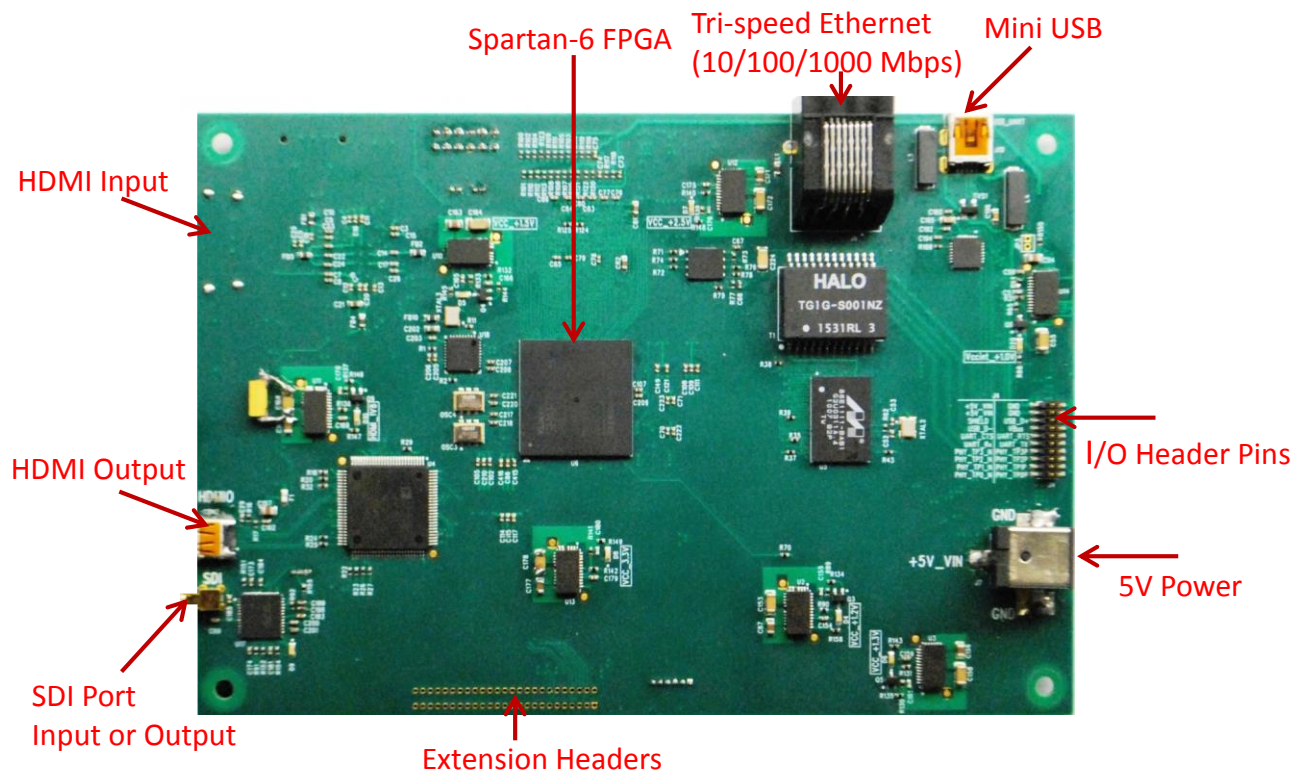

Fig. 11. FMC-MCM-1000 evaluation board

Table-A2: H.265 Video&Audio Encoder Modules (both video and audio):

Product #	Specifications						
	Standard	Profile	Resolution	Chroma	Precision	Frame Rate	Audio
EC-VA-H265-8b-30-1080-M	H.265	Main 4:2:2 12	up to 1080i/p	4:2:0/4:2:2	8 bits	up to 30fps	AAC or MPEG2 Layer-2
EC-VA-H265-10b-30-1080-M	H.265	Main 4:2:2 12	up to 1080i/p	4:2:0/4:2:2	up to 10 bits	up to 30fps	AAC or MPEG2 Layer-2
EC-VA-H265-12b-30-1080-M	H.265	Main 4:2:2 12	up to 1080i/p	4:2:0/4:2:2	up to 12 bits	up to 30fps	AAC or MPEG2 Layer-2
EC-VA-H265-8b-60-1080-M	H.265	Main 4:2:2 12	up to 1080i/p	4:2:0/4:2:2	8 bits	up to 60fps	AAC or MPEG2 Layer-2
EC-VA-H265-10b-60-1080-M	H.265	Main 4:2:2 12	up to 1080i/p	4:2:0/4:2:2	up to 10 bits	up to 60fps	AAC or MPEG2 Layer-2
EC-VA-H265-12b-60-1080-M	H.265	Main 4:2:2 12	up to 1080i/p	4:2:0/4:2:2	up to 12 bits	up to 60fps	AAC or MPEG2 Layer-2
EC-VA-H265-8b-30-4k-M	H.265	Main 4:2:2 12	4k/UHD	4:2:0/4:2:2	8 bits	up to 30fps	AAC or MPEG2 Layer-2
EC-VA-H265-10b-30-4k-M	H.265	Main 4:2:2 12	4k/UHD	4:2:0/4:2:2	up to 10 bits	up to 30fps	AAC or MPEG2 Layer-2
EC-VA-H265-12b-30-4k-M	H.265	Main 4:2:2 12	4k/UHD	4:2:0/4:2:2	up to 12 bits	up to 30fps	AAC or MPEG2 Layer-2
EC-VA-H265-8b-60-4k-M	H.265	Main 4:2:2 12	4k/UHD	4:2:0/4:2:2	8 bits	up to 60fps	AAC or MPEG2 Layer-2
EC-VA-H265-10b-60-4k-M	H.265	Main 4:2:2 12	4k/UHD	4:2:0/4:2:2	up to 10 bits	up to 60fps	AAC or MPEG2 Layer-2
EC-VA-H265-12b-60-4k-M	H.265	Main 4:2:2 12	4k/UHD	4:2:0/4:2:2	up to 12bits	up to 60fps	AAC or MPEG2 Layer-2

A.2 H.264 Encoder Modules

The H.264 encoder modules are based on either the on the MCM-1000A hardware. The SOC H.264 encoder IP cores are used to configure the FPGAs on the hardware modules to produce the codec modules.

Table-A3 lists the product code of the factory standard video encoder modules (video only), along with the specifications for each module. Table-A4 lists the video/audio encoder modules (both video and audio). Customers can order the encoder modules using the product code, according to the specifications required by the application.

Table-A3: H.264 Video Encoder Modules (video only without audio):

Product #	Specifications							Hardware
	Standard	Profile	Resolution	Chroma	Precision	Frame Rate	Audio	
EC-V-H264-8b-30-720-MS	H.264	up to High	up to 720i/p	4:2:0/4:2:2	8 bits	up to 30fps	no	MCM-1000A
EC-V-H264-8b-60-720-MS	H.264	up to High	up to 720i/p	4:2:0/4:2:2	8 bits	up to 60fps	no	MCM-1000A
EC-V-H264-8b-30-1080-MS	H.264	up to High	up to 1080i/p	4:2:0/4:2:2	8 bits	up to 30fps	no	MCM-1000A
EC-V-H264-10b-30-1080-MS	H.264	up to High	up to 1080i/p	4:2:0/4:2:2	up to 10 bits	up to 30fps	no	MCM-1000A
EC-V-H264-8b-60-1080-MA	H.264	up to High	up to 1080i/p	4:2:0/4:2:2	8 bits	up to 60fps	no	MCM-1000A
EC-V-H264-10b-60-1080-MA	H.264	up to High	up to 1080i/p	4:2:0/4:2:2	up to 10 bits	up to 60fps	no	MCM-1000A
EC-V-H264-8b-30-4k-MZ	H.264	High	4kx2k	4:2:0/4:2:2	up to 8 bits	up to 30fps	no	MCM-1000Z
EC-V-H264-10b-30-4k-MZ	H.264	High	4kx2k	4:2:0/4:2:2	up to 10 bits	up to 30fps	no	MCM-1000Z
EC-V-H264-8b-60-4k-MZ	H.264	High	4kx2k	4:2:0/4:2:2	up to 8 bits	up to 60fps	no	MCM-1000Z
EC-V-H264-10b-60-4k-MZ	H.264	High	4kx2k	4:2:0/4:2:2	up to 10 bits	up to 60fps	no	MCM-1000Z

Table-A4: H.264 Video&Audio Encoder Modules (both video and audio):

Product #	Specifications							Hardware
	Standard	Profile	Resolution	Chroma	Precision	Frame Rate	Audio	
EC-VA-H264-8b-30-720-MS	H.264	up to High	up to 720i/p	4:2:0/4:2:2	8 bits	up to 30fps	AAC/MPEG2 L-2	MCM-1000A
EC-VA-H264-8b-60-720-MS	H.264	up to High	up to 720i/p	4:2:0/4:2:2	8 bits	up to 60fps	AAC/MPEG2 L-2	MCM-1000A
EC-VA-H264-8b-30-1080-MS	H.264	up to High	up to 1080i/p	4:2:0/4:2:2	8 bits	up to 30fps	AAC/MPEG2 L-2	MCM-1000A
EC-VA-H264-10b-30-1080-MS	H.264	up to High	up to 1080i/p	4:2:0/4:2:2	up to 10bits	up to 30fps	AAC/MPEG2 L-2	MCM-1000A
EC-VA-H264-8b-60-1080-MA	H.264	up to High	up to 1080i/p	4:2:0/4:2:2	8 bits	up to 60fps	AAC/MPEG2 L-2	MCM-1000A
EC-VA-H264-10b-60-1080-MA	H.264	up to High	up to 1080i/p	4:2:0/4:2:2	up to 10 bits	up to 60fps	AAC/MPEG2 L-2	MCM-1000A
EC-VA-H264-8b-30-4k-MZ	H.264	High	4kx2k	4:2:0/4:2:2	8 bits	up to 30fps	AAC/MPEG2 L-2	MCM-1000Z
EC-VA-H264-10b-30-4k-MZ	H.264	High	4kx2k	4:2:0/4:2:2	10 bits	up to 30fps	AAC/MPEG2 L-2	MCM-1000Z
EC-VA-H264-8b-60-4k-MZ	H.264	High	4kx2k	4:2:0/4:2:2	8 bits	up to 60fps	AAC/MPEG2 L-2	MCM-1000Z
EC-VA-H264-10b-60-4k-MZ	H.264	High	4kx2k	4:2:0/4:2:2	10 bits	up to 60fps	AAC/MPEG2 L-2	MCM-1000Z

A.3 H.264 Decoder Modules

Hardware platform MCM-1000A is used for the H.264 HD decoders. Table-A5 lists the factory standard H.264 video decoder modules (video only), along with the product code and specifications. Table-A6 lists the factory standard H.264 video and audio decoder modules, product code, specifications.

Table-A5: H.264 Video Decoder Modules (video only without audio):

Product #	Specifications							Hardware
	Standard	Profile	Resolution	Chroma	Precision	Frame Rate	Audio	
DC-V-H264-8b-30-720-MA	H.264	up to High	up to 720i/p	4:2:0/4:2:2	8 bits	up to 30fps	no	MCM-1000A
DC-V-H264-8b-60-720-MA	H.264	up to High	up to 720i/p	4:2:0/4:2:2	8 bits	up to 60fps	no	MCM-1000A
DC-V-H264-8b-30-1080-MA	H.264	up to High	up to 1080i/p	4:2:0/4:2:2	8 bits	up to 30fps	no	MCM-1000A
DC-V-H264-10b-30-1080-MA	H.264	up to High	up to 1080i/p	4:2:0/4:2:2	up to 10 bits	up to 30fps	no	MCM-1000A
DC-V-H264-8b-60-1080-MA	H.264	up to High	up to 1080i/p	4:2:0/4:2:2	8 bits	up to 60fps	no	MCM-1000A
DC-V-H264-10b-60-1080-MA	H.264	up to High	up to 1080i/p	4:2:0/4:2:2	up to 10 bits	up to 60fps	no	MCM-1000A
DC-V-H264-8b-30-4k-MZ	H.264	High	4kx2k	4:2:0/4:2:2	8 bits	up to 30fps	no	MCM-1000Z
DC-V-H264-10b-30-4k-MZ	H.264	High	4kx2k	4:2:0/4:2:2	10 bits	up to 30fps	no	MCM-1000Z
DC-V-H264-8b-60-4k-MZ	H.264	High	4kx2k	4:2:0/4:2:2	8 bits	up to 60fps	no	MCM-1000Z
DC-V-H264-10b-60-4k-MZ	H.264	High	4kx2k	4:2:0/4:2:2	10 bits	up to 60fps	no	MCM-1000Z

A.5 MPEG-2 Decoder Modules

Table-A9 lists the standard MPEG-2 video decoder modules. Table-A10 lists the MPEG-2 video/audio decoder modules. The 10-bit precision and 60 frames/second modules are offered as extensions of the MPEG-2 standard.

Table-A9: MPEG-2 Video Decoder Modules (video only without audio):

Product #	Specifications							Hardware
	Standard	Profile	Resolution	Chroma	Precision	Frame Rate	Audio	
DC-V-MPEG2-8b-30-720-MS	MPEG-2	up to High	up to 720i/p	4:2:0/4:2:2	8 bits	up to 30fps	no	MCM-1000S
DC-V-MPEG2-8b-60-720-MA	MPEG-2	up to High	up to 720i/p	4:2:0/4:2:2	8 bits	up to 60fps	no	MCM-1000A
DC-V-MPEG2-8b-30-1080-MS	MPEG-2	up to High	up to 1080i/p	4:2:0/4:2:2	8 bits	up to 30fps	no	MCM-1000S
DC-V-MPEG2-8b-60-1080-MA	MPEG-2	up to High	up to 1080i/p	4:2:0/4:2:2	8 bits	up to 60fps	no	MCM-1000A

Table-A10: MPEG-2 Video&Audio Decoder Modules (both video and audio):

Product #	Specifications							Hardware
	Standard	Profile	Resolution	Chroma	Precision	Frame Rate	Audio	
DC-V-MPEG2-8b-30-720-MS	MPEG-2	up to High	up to 720i/p	4:2:0/4:2:2	8 bits	up to 30fps	AAC/MPEG2 L-2	MCM-1000S
DC-V-MPEG2-8b-60-720-MA	MPEG-2	up to High	up to 720i/p	4:2:0/4:2:2	8 bits	up to 60fps	AAC/MPEG2 L-2	MCM-1000A
DC-V-MPEG2-8b-30-1080-MS	MPEG-2	up to High	up to 1080i/p	4:2:0/4:2:2	8 bits	up to 30fps	AAC/MPEG2 L-2	MCM-1000S
DC-V-MPEG2-8b-60-1080-MA	MPEG-2	up to High	up to 1080i/p	4:2:0/4:2:2	8 bits	up to 60fps	AAC/MPEG2 L-2	MCM-1000A

A.6 H.264-to-H.265 Transcoder Modules

Table-A11 lists the standard H.264-to-H.265 video transcoder modules. Table-A12 lists the H.264-to-H.265 video/audio transcoder modules.

Table-A11: H.264-to-H.265 Video Transcoder Modules (video only without audio):

Product #	Specifications							Hardware
	Standard	Profile	Resolution	Chroma	Precision	Frame Rate	Audio	
TC-V-H.264-to-H.265-8b-30-720-MZ	H.265	Main 4:2:2	up to 720i/p	up to 4:2:2	8 bits	up to 30fps	no	MCM-1000Z
TC-V-H.264-to-H.265-10b-30-720-MZ	H.265	Main 4:2:2	up to 720i/p	up to 4:2:2	10 bits	up to 30fps	no	MCM-1000Z
TC-V-H.264-to-H.265-8b-60-720-MZ	H.265	Main 4:2:2	up to 720i/p	up to 4:2:2	8 bits	up to 60fps	no	MCM-1000Z
TC-V-H.264-to-H.265-10b-60-720-MZ	H.265	Main 4:2:2	up to 720i/p	up to 4:2:2	10 bits	up to 60fps	no	MCM-1000Z
TC-V-H.264-to-H.265-8b-30-1080-MZ	H.265	Main 4:2:2	up to 1080i/p	up to 4:2:2	8 bits	up to 30fps	no	MCM-1000Z
TC-V-H.264-to-H.265-10b-30-1080-MZ	H.265	Main 4:2:2	up to 1080i/p	up to 4:2:2	10 bits	up to 30fps	no	MCM-1000Z
TC-V-H.264-to-H.265-8b-60-1080-MZ	H.265	Main 4:2:2	up to 1080i/p	up to 4:2:2	8 bits	up to 60fps	no	MCM-1000Z
TC-V-H.264-to-H.265-10b-60-1080-MZ	H.265	Main 4:2:2	up to 1080i/p	up to 4:2:2	10 bits	up to 60fps	no	MCM-1000Z

Appendix - B MCM-1000A Edge Connector Schematics

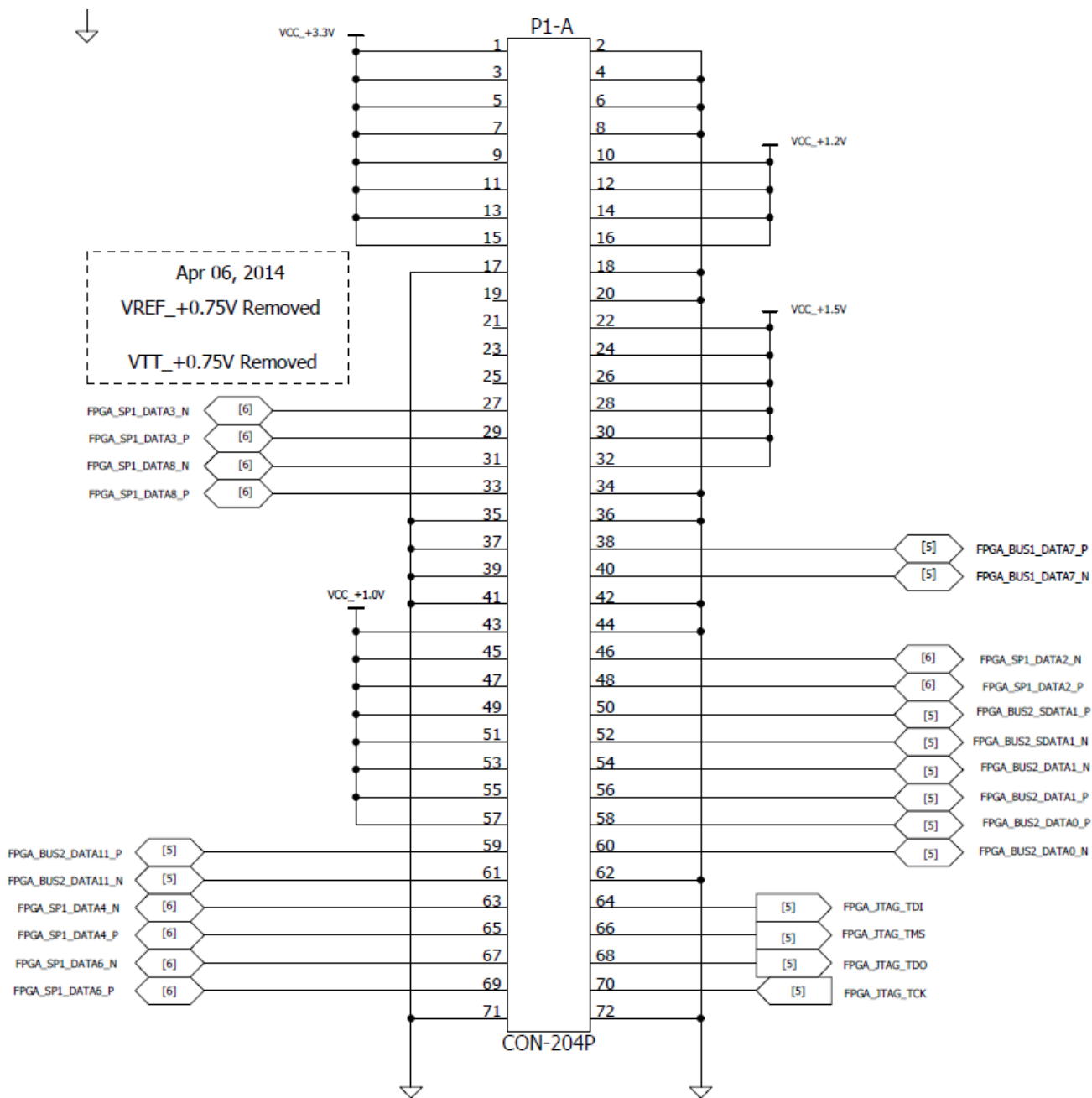

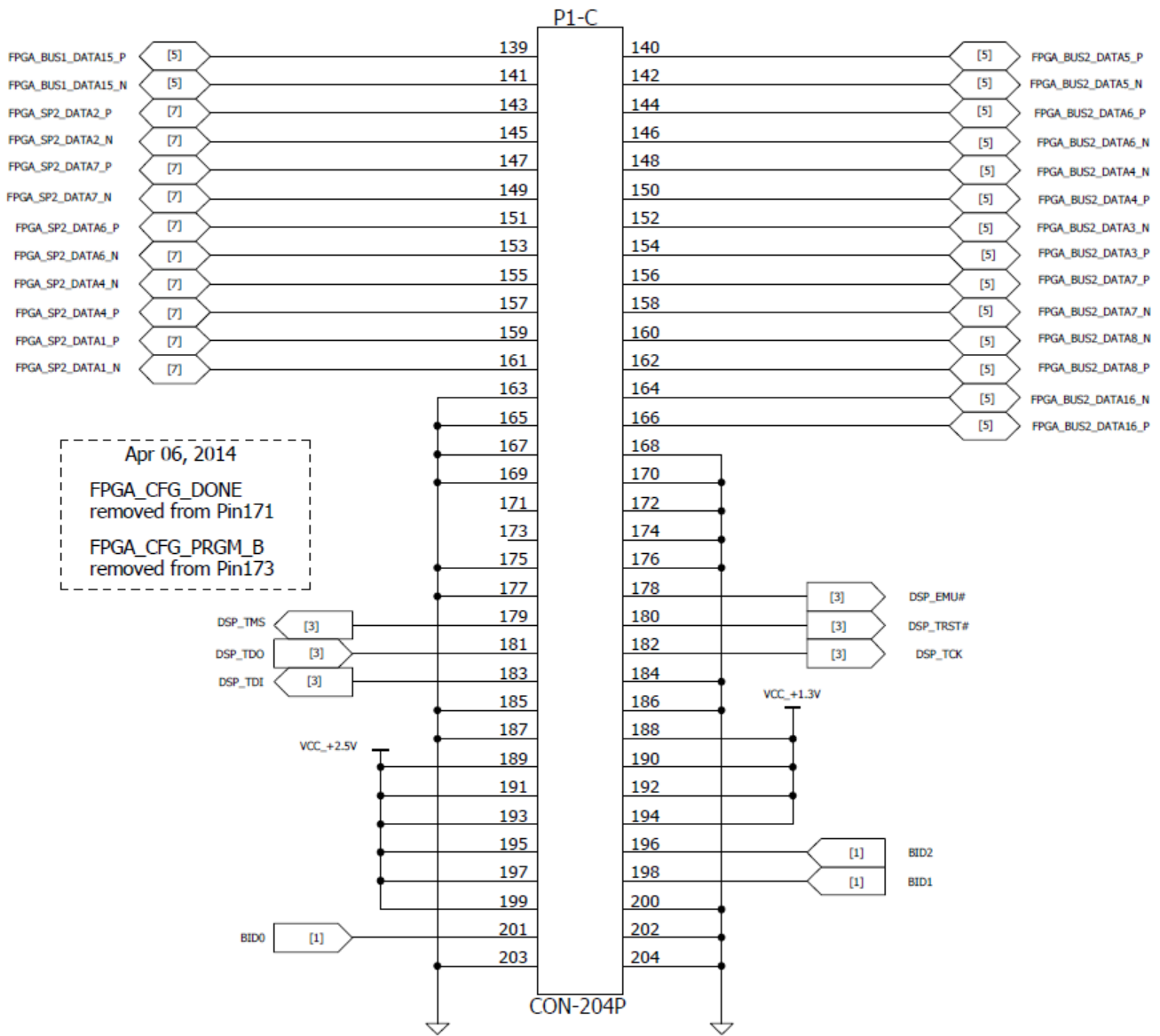

Appendix - C MCM-1000Z Edge Connector Schematics

