



Welcome to E-XFL.COM

Understanding [Embedded - Microcontroller, Microprocessor, FPGA Modules](#)

Embedded - Microcontroller, Microprocessor, and FPGA Modules are fundamental components in modern electronic systems, offering a wide range of functionalities and capabilities. Microcontrollers are compact integrated circuits designed to execute specific control tasks within an embedded system. They typically include a processor, memory, and input/output peripherals on a single chip. Microprocessors, on the other hand, are more powerful processing units used in complex computing tasks, often requiring external memory and peripherals. FPGAs (Field Programmable Gate Arrays) are highly flexible devices that can be configured by the user to perform specific logic functions, making them invaluable in applications requiring customization and adaptability.

Applications of [Embedded - Microcontroller,](#)

Details

Product Status	Discontinued at Digi-Key
Module/Board Type	FPGA Core
Core Processor	Artix-7 A200T
Co-Processor	-
Speed	-
Flash Size	32MB
RAM Size	256KB
Connector Type	SO-DIMM-204
Size / Dimension	2.7" x 2.0" (68mm x 51mm)
Operating Temperature	0°C ~ 85°C
Purchase URL	https://www.e-xfl.com/product-detail/soc-technologies/ec-v-h264-8b-60-1080-mxc-sl

12. Carrier Board References

12.1 VTR-S1000 Board

12.2 VTR-4000C Board

13. Ordering Information

14. Contact Information

15. Document Versions

Appendix-A SOC Standard Codec Modules

Appendix-B MCM-1000A Edge Connector Schematics

Appendix-C MCM-1000Z Edge Connector Schematics

1. Overview of SOC SOM Modules

The SOC SOMs are small circuit boards with FPGA, DDRs, Flash, and clocks in one module to support FPGA-based systems. A module can be configured into a SOM by using the applicable firmware. The module is connected to a user PCB through a standard DDR3 SODIMM connector. Customers can order the blank SOMs from SOC and use their own firmware to make SOM products.

SOC configures the modules into MPEG codec SOMs for video/audio compression, decompression, and transcoding functions. Currently available modules are:

	Hardware Product Code	FPGA Chip on the Module	SOC Codec module Resolution Capacity
1	MCM-1000S	Spartan-6 XC6SLX150	H.264 or MPEG-2 HD up to 1080@30
2	MCM-1000A	Artix-7 XC7A200T	H.264 or MPEG-2 HD up to 1080@60
3	MCM-1000Z	Zynq-7 XC7Z035/045	H.264 4k@30/60, or H.265 HD up to 1080@60
4	MCM-1000SX	Arria-10 SX220/270/320/480/570/660	H.264 HD 1080@30/60, or H.264 4k@30/60, or H.265 HD up to 1080@60), or H.265 4k@30/60

Fig. 1 shows a photo of the modules. Fig. 2-5 shows the dimensions of MCM-1000S, MCM-1000A, MCM-1000Z, and MCM-1000SX respectively.



Fig. 1 SOC codec modules

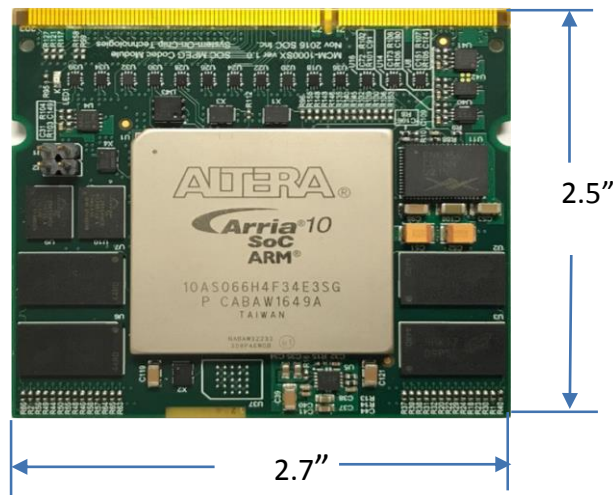

Fig. 5. Dimension of MCM-1000SX

2. Connecting the Module to a User PCB

The MCM-1000S/A/Z/SX modules have identical edge pins that are compatible with standard DDR3 SODIMM connectors. The following off-the-shelf DDR3 SODIMM connectors can be used to connect the SOC codec modules onto a user PCB:

1. MM80-204B1-1
2. MM80-204B1-1E
3. AS0A621-U2SN-7F
4. AS0A621-H2S6-7H

Fig. 6 shows a photo of a standard 204 pin DDR3 SODIMM PCB connector. Refer to the datasheet of the connector used for the physical dimension and PCB design requirements.



Fig. 6 A photo of the standard 204 pin DDR3 SODIMM connector

3. Overview SOC Standard Codec Modules

Each of the above described SOMs: the **MCM-1000S** (based on Spartan-6 FPGA), **MCM-1000A** (based on Artix-7 FPGA), **MCM-1000Z** (based on Zynq-7 FPGAs), and **MCM-1000SX** (based on Altera Arria-10 FPGAs); can be configured into different products by down-loading the desired firmware. At SOC, we produce encoder, decoder, transcoder, and multi-channel encoder or decoder SOMs for video compressions, by down-loading **SOC MPEG Codec IP** cores onto the modules.

The standard encoder modules: H.265, H.264, and MPEG-2, take raw video and audio as input and output TS streams, via the edge pins of the modules, as shown in Fig. 7. The standard decoder modules: H.265, H.264, and MPEG-2, take TS stream as inputs and output decoded video and audio, via the edge pins of the modules, as shown in Fig. 8. There are also control signal pins, to allow the user control of the encoder or decoder.

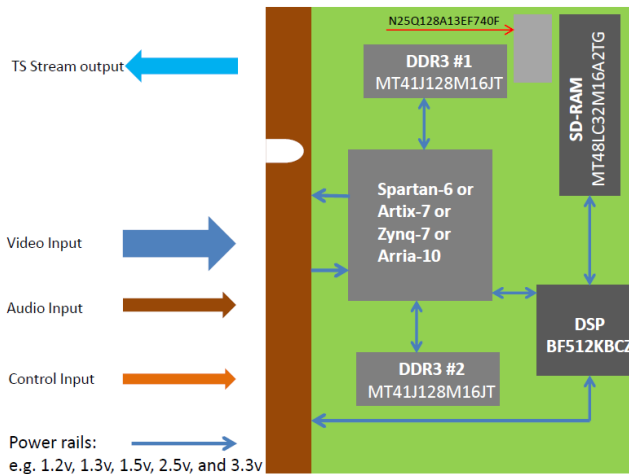

Fig. 7 SOC Standard encoder modules (H.265, H.264, or MPEG-2)

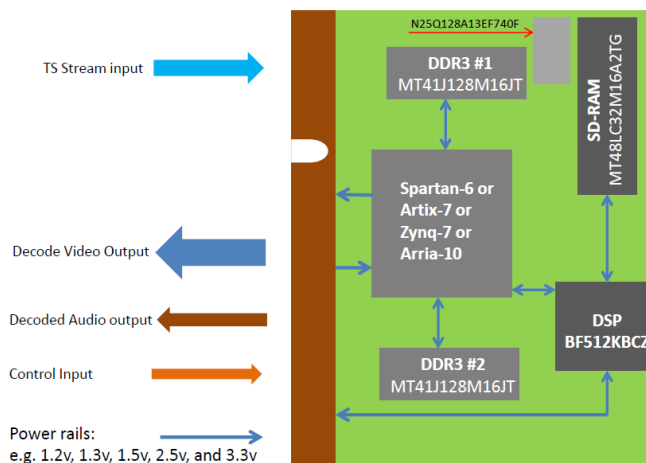

Fig. 8 SOC Standard decoder modules (H.265, H.264, or MPEG-2)

Appendix-A provides the details of the Standard Codec Modules, including the product tables which list the product codes along with the specifications. Customers can order the modules according the specifications required by using the corresponding product code.

The pin assignments, pin voltages, and signal formats for standard encoder and decoder modules are detailed respectively in this Datasheet in the following sections:

- Section 4: The H.264 (and MPEG-2) HD Encoder Modules
- Section 5: The H.264 (and MPEG-2) HD Decoder Modules
- Section 6: The H.264 4k Encoder Modules
- Section 7: The H.264 4k Decoder Modules
- Section 8: The H.265 HD Encoder Modules
- Section 9: The H.265 HD Decoder Modules (will be available soon)
- Section 10: The H.265 4k Encoder Modules
- Section 11: The H.265 4k Decoder Modules (will be available soon)

It should be noted that not all of the modules listed in Appendix-A are discussed in this Datasheet. Pin assignments and electrical properties for the modules that are not provided in the document, will be provided on demand basis.

SOC also offers customized modules according to customer requirements, such as Transcoder modules, Multi-channel encoder or decoder modules, and modules with non-standard I/Os. For details, contact SOC sales at: sales@soctechnologies.com

One of the popular extended versions of the standard codec modules is the –NET version which integrates the SOC low latency network stack (UDP/IP over Ethernet) into the encoder or decoder module. The pin assignments, pin voltages, and signal formats for the –NET version encoder and decoder modules are detailed in the document:

[Datasheet – Encoder and Decoder Modules – NET Version](#)

4. The H.264 (and MPEG-2) HD Encoder Modules

4.1 Pin Assignments and Pin Voltages

The HD encoder modules for H.264 and MPEG-2 have the same pin assignments and electrical properties. The hardware module for HD resolution uses the MCM-1000A (the Artix-7 A200T FPGA), the hardware module MCM-1000Z is used for 4k resolutions (the Zynq-7035 for 4k@30, Zynq-7045 for 4k@60).

This Section provides the pin assignments and electrical properties for HD encoder (H.264, or MPEG-2) module which is based on the MCM-1000A. Table-1 lists the pin assignments and the pin voltages.

The schematics of MCM-1000A edge connector are attached in Appendix-B of this document, which shows the pin numbers for data, clock, control, and power. It should be noted that the encoder module uses only some of the edge pins, and not all of the edge pins are used.

Table-1 also lists the FPGA pin numbers that are connected to the edge pins assigned to the encoder. The Artix-7 datasheet provides further information regarding the properties of these pins, and can be used as a reference.

Table 1: HD Encoder Module (based on MCM-1000A) Pin Assignment and Pin Voltages

Description	MCM-1000A Edge Connector Pin #	Direction	FPGA Pin #	Voltage	IO Standard
External Reset	121	Input	W21	3.3v	LVCNOS33
Video Clock	105	Input	Y11	3.3v	LVCNOS33
Video Horizontal Sync	146	Input	W16	3.3v	LVCNOS33
Video Vertical Sync	148	Input	V15	3.3v	LVCNOS33
Video Display Enable	150	Input	U15	3.3v	LVCNOS33
Video Data Luma[0]	50	Input	W14	3.3v	LVCNOS33
Video Data Luma[1]	52	Input	Y14	3.3v	LVCNOS33
Video Data Luma[2]	58	Input	V10	3.3v	LVCNOS33
Video Data Luma[3]	59	Input	Y13	3.3v	LVCNOS33
Video Data Luma[4]	60	Input	W10	3.3v	LVCNOS33
Video Data Luma[5]	61	Input	AA14	3.3v	LVCNOS33
Video Data Luma[6]	80	Input	AB13	3.3v	LVCNOS33
Video Data Luma[7]	82	Input	AA13	3.3v	LVCNOS33
Video Data Luma[8]	84	Input	AB17	3.3v	LVCNOS33
Video Data Luma[9]	86	Input	AB16	3.3v	LVCNOS33
Video Data Chroma[0]	92	Input	AA15	3.3v	LVCNOS33
Video Data Chroma[1]	94	Input	AB15	3.3v	LVCNOS33
Video Data Chroma[2]	96	Input	AB12	3.3v	LVCNOS33
Video Data Chroma[3]	98	Input	AB11	3.3v	LVCNOS33
Video Data Chroma[4]	107	Input	Y12	3.3v	LVCNOS33
Video Data Chroma[5]	108	Input	W12	3.3v	LVCNOS33
Video Data Chroma[6]	110	Input	Y17	3.3v	LVCNOS33
Video Data Chroma[7]	140	Input	T14	3.3v	LVCNOS33
Video Data Chroma[8]	142	Input	T15	3.3v	LVCNOS33
Video Data Chroma[9]	144	Input	W15	3.3v	LVCNOS33
SPDIF Audio	109	Input	Y21	3.3v	LVCNOS33

Transport Stream Buffer Ready	112	Input	AA20	3.3v	LVC MOS33
Transport Stream Clock	93	Output	Y18	3.3v	LVC MOS33
Transport Stream Data Valid	106	Output	R17	3.3v	LVC MOS33
Transport Stream Data[0]	77	Output	N13	3.3v	LVC MOS33
Transport Stream Data[1]	79	Output	N14	3.3v	LVC MOS33
Transport Stream Data[2]	81	Output	R18	3.3v	LVC MOS33
Transport Stream Data[3]	83	Output	T18	3.3v	LVC MOS33
Transport Stream Data[4]	85	Output	U17	3.3v	LVC MOS33
Transport Stream Data[5]	87	Output	U18	3.3v	LVC MOS33
Transport Stream Data[6]	89	Output	AB18	3.3v	LVC MOS33
Transport Stream Data[7]	91	Output	AA18	3.3v	LVC MOS33
Transport Stream Start Code	40	Output	V19	3.3v	LVC MOS33
Uart_tx	90	Output	AA16	3.3v	LVC MOS33
Uart_rx	88	Input	Y16	3.3v	LVC MOS33

4.2 Signal Formats

4.2.1 Video Clock Signal (Input)

The **Video Clock** signal (pin # 105) has two functions: (1) It is the clock for the input video data, and (2) it is the clock that drives the encoder engine.

The **Video Clock** signal usually comes from the video input interface chip, such as HDMI or SDI. It is the clock for the input video data. It is also used for driving the encoder engine. The frequency varies according to the resolution of the video input. The following are the clock frequencies for standard video resolutions.

1. 27MHz, for SD resolution
2. 74.25MHz, for 720@60 and 1080@30
3. 148.5MHz, for 1080@60

4.2.2 Video Data Signals (Input)

The input to the encoder module (H.264 or MPEG-2) is raw video data in YUV format (4:2:2 or 4:2:0), with 10 input lines: **Video Data Luma[0]** to **Video Data Luma[9]**, for Luma. And, 10 input lines: **Video Data Chroma[0]** to **Video Data Chroma[9]**, for the Chroma. The precision can be either 8-bit or 10-bit. When 8-bit precision is used, **Video Data Luma[0]**, **Video Data Luma[1]**, **Video Data Chroma[0]**, and **Video Data Chroma[1]** are zeros.

In addition to the video Luma and Chroma data signals, the **Video Horizontal Sync** and **Video Vertical Sync** signals are required for frame synchronization. A **Video Clock** (refer to Section 4.2.1 for the clock frequencies) is required, which provides the timing for the parallel input of luma, chroma, as well as for the **Video Horizontal Sync** and **Video Vertical Sync** signals. The **Video Display Enable** signal (pin #150) is a part of the **Video Horizontal Sync** and **Video Vertical Sync** system, where high signal indicates active video pixels. For example, an HDMI input interface chip will output the **Display Enable signal** at high, when active pixels are being sent out.

The video data are sampled at the rising edge of the clock. The clock rates will correspond to the resolution and frame rate, as discussed in Section 4.2.1.

SPDIF Audio	109	Output	Y21	3.3v	LVC MOS33
Transport Stream Clock (27MHz)	93	Output	Y18	3.3v	LVC MOS33
Transport Stream Data Valid	106	Output	R17	3.3v	LVC MOS33
Transport Stream Data[0]	77	Output	N13	3.3v	LVC MOS33
Transport Stream Data[1]	79	Output	N14	3.3v	LVC MOS33
Transport Stream Data[2]	81	Output	R18	3.3v	LVC MOS33
Transport Stream Data[3]	83	Output	T18	3.3v	LVC MOS33
Transport Stream Data[4]	85	Output	U17	3.3v	LVC MOS33
Transport Stream Data[5]	87	Output	U18	3.3v	LVC MOS33
Transport Stream Data[6]	89	Output	AB18	3.3v	LVC MOS33
Transport Stream Data[7]	91	Output	AA18	3.3v	LVC MOS33
Uart_tx	90	Output	AA16	3.3v	LVC MOS33
Uart_rx	88	Input	Y16	3.3v	LVC MOS33

5.2 Signal Formats

5.2.1 Clock Signals

The **Decoder Clock** signal (pin # 115) is an input clock for driving the decoder engine. The default frequency is **27MHz**. However, when an SDI port on the carrier board is used to send out the decoded video data, the SDI clock can be connected to the **Decoder Clock**. This will automatically synchronize the decoder outputs with the SDI interface.

The SDI clock frequencies are:

1. 27MHz, for SD resolution
2. 74.25MHz, for 720@60 and 1080@30
3. 148.5MHz, for 1080@60

The **Video Clock** signal (pin # 105) is the clock for the video data output by the decoder. The frequency of the **Video clock** is determined by the video resolution, which are:

4. 27MHz, for SD resolution
5. 74.25MHz, for 720@60 and 1080@30
6. 148.5MHz, for 1080@60.

5.2.2 Video Data Signals (Output)

The output of the HD decoder module (H.264 or MPEG-2) is the decoded video data in YUV format (4:2:2 or 4:2:0), with 10 input lines: **Video Data Luma[0]** to **Video Data Luma[9]**, for Luma and 10 lines. And, **Video Data Chroma[0]**

6. The H.264 4k Encoder Modules

6.1 Pin Assignments and Pin Voltages

The modules for 4K resolution uses the MCM-1000Z hardware, with the MCM-1000Z35 (Zynq-7035 FPGA) for 4k@30 and MCM-1000Z45 (Zynq-7045 FPGA) for 4k@60. The pin assignment and electrical properties are the same for MCM-1000Z35 and MCM-1000Z45.

Table-6 lists the pin assignments and the pin voltages for the 4K encoder modules based on the MCM-1000Z (MCM-1000Z35 and MCM-1000Z45 are the same).

The schematics of MCM-1000Z edge connector are attached in Appendix-C of this document, which shows the pin numbers for data, clock, control, and power.

Table-6 also lists the FPGA pin numbers that are connected to the edge pins assigned to the encoder. The Zynq-7000 datasheet provides further information regarding the properties of these pins, and can be used as a reference.

Table-6: 4K Encoder Module (based on MCM-1000Z) Pin Assignment and Pin Voltages

Description	MCM-1000Z Edge Connector Pin #	Direction	FPGA Pin #	Voltage	IO Standard
PS Soft Reset B	156	Input	B19	3.3V	LVC MOS33
Video Clock 0	63	Input	AC18	1.5v	LVC MOS15
Video Clock 1	80	Input	AF15	3.3v	LVC MOS33
Video Clock 2	144	Input	AE28	3.3v	LVC MOS33
Video Clock 3	105	Input	AG21	3.3v	LVC MOS33
Video Horizontal Sync	133	Input	W24	1.5v	LVC MOS15
Video Vertical Sync	113	Input	AF22	3.3v	LVC MOS33
Video Display Enable	67	Input	AD18	1.5v	LVC MOS15
Video Data 0 Luma[0]	135	Input	W25	1.5v	LVC MOS15
Video Data 0 Luma[1]	137	Input	W26	1.5v	LVC MOS15
Video Data 0 Luma[2]	116	Input	V27	1.5v	LVC MOS15
Video Data 0 Luma[3]	118	Input	W28	1.5v	LVC MOS15
Video Data 0 Luma[4]	124	Input	W29	1.5v	LVC MOS15
Video Data 0 Luma[5]	126	Input	W30	1.5v	LVC MOS15
Video Data 0 Luma[6]	128	Input	V28	1.5v	LVC MOS15
Video Data 0 Luma[7]	130	Input	V29	1.5v	LVC MOS15
Video Data 0 Luma[8]	132	Input	T30	1.5v	LVC MOS15
Video Data 0 Luma[9]	134	Input	U30	1.5v	LVC MOS15
Video Data 1 Luma[0]	117	Input	AG22	3.3v	LVC MOS33
Video Data 1 Luma[1]	119	Input	AH22	3.3v	LVC MOS33
Video Data 1 Luma[2]	121	Input	AJ21	3.3v	LVC MOS33
Video Data 1 Luma[3]	123	Input	AK21	3.3v	LVC MOS33

Video Data 1 Luma[4]	125	Input	AF23	3.3v	LVC MOS33
Video Data 1 Luma[5]	127	Input	AF24	3.3v	LVC MOS33
Video Data 1 Luma[6]	92	Input	AJ23	3.3v	LVC MOS33
Video Data 1 Luma[7]	94	Input	AJ24	3.3v	LVC MOS33
Video Data 1 Luma[8]	96	Input	AG24	3.3v	LVC MOS33
Video Data 1 Luma[9]	98	Input	AG25	3.3v	LVC MOS33
Video Data 2 Luma[0]	77	Input	AJ16	3.3v	LVC MOS33
Video Data 2 Luma[1]	79	Input	AK16	3.3v	LVC MOS33
Video Data 2 Luma[2]	81	Input	AH17	3.3v	LVC MOS33
Video Data 2 Luma[3]	83	Input	AH16	3.3v	LVC MOS33
Video Data 2 Luma[4]	85	Input	AH18	3.3v	LVC MOS33
Video Data 2 Luma[5]	87	Input	AJ18	3.3v	LVC MOS33
Video Data 2 Luma[6]	78	Input	AF13	3.3v	LVC MOS33
Video Data 2 Luma[7]	82	Input	AG15	3.3v	LVC MOS33
Video Data 2 Luma[8]	84	Input	AG17	3.3v	LVC MOS33
Video Data 2 Luma[9]	86	Input	AG16	3.3v	LVC MOS33
Video Data 3 Luma[0]	107	Input	AH21	3.3v	LVC MOS33
Video Data 3 Luma[1]	122	Input	AH29	3.3v	LVC MOS33
Video Data 3 Luma[2]	115	Input	AE22	3.3v	LVC MOS33
Video Data 3 Luma[3]	146	Input	AF28	3.3v	LVC MOS33
Video Data 3 Luma[4]	148	Input	AF29	3.3v	LVC MOS33
Video Data 3 Luma[5]	150	Input	AG29	3.3v	LVC MOS33
Video Data 3 Luma[6]	100	Input	AH23	3.3v	LVC MOS33
Video Data 3 Luma[7]	102	Input	AH24	3.3v	LVC MOS33
Video Data 3 Luma[8]	104	Input	AJ25	3.3v	LVC MOS33
Video Data 3 Luma[9]	106	Input	AK25	3.3v	LVC MOS33
Video Data 0 Chroma[0]	143	Input	T29	1.5v	LVC MOS15
Video Data 0 Chroma[1]	145	Input	U29	1.5v	LVC MOS15
Video Data 0 Chroma[2]	147	Input	R28	1.5v	LVC MOS15
Video Data 0 Chroma[3]	149	Input	T28	1.5v	LVC MOS15
Video Data 0 Chroma[4]	151	Input	P30	1.5v	LVC MOS15
Video Data 0 Chroma[5]	153	Input	R30	1.5v	LVC MOS15
Video Data 0 Chroma[6]	155	Input	N29	1.5v	LVC MOS15
Video Data 0 Chroma[7]	157	Input	P29	1.5v	LVC MOS15
Video Data 0 Chroma[8]	159	Input	N28	1.5v	LVC MOS15
Video Data 0 Chroma[9]	161	Input	P28	1.5v	LVC MOS15
Video Data 1 Chroma[0]	89	Input	AK17	3.3v	LVC MOS33
Video Data 1 Chroma[1]	91	Input	AK18	3.3v	LVC MOS33
Video Data 1 Chroma[2]	93	Input	AF19	3.3v	LVC MOS33
Video Data 1 Chroma[3]	95	Input	AG19	3.3v	LVC MOS33
Video Data 1 Chroma[4]	97	Input	AH19	3.3v	LVC MOS33
Video Data 1 Chroma[5]	99	Input	AJ19	3.3v	LVC MOS33
Video Data 1 Chroma[6]	101	Input	AF20	3.3v	LVC MOS33
Video Data 1 Chroma[7]	103	Input	AG20	3.3v	LVC MOS33
Video Data 1 Chroma[8]	109	Input	AJ20	3.3v	LVC MOS33
Video Data 1 Chroma[9]	111	Input	AK20	3.3v	LVC MOS33
Video Data 2 Chroma[0]	38	Input	AE12	3.3v	LVC MOS33
Video Data 2 Chroma[1]	40	Input	AF12	3.3v	LVC MOS33

Video Data 2 Chroma[2]	50	Input	AG12	3.3v	LVC MOS33
Video Data 2 Chroma[3]	52	Input	AH12	3.3v	LVC MOS33
Video Data 2 Chroma[4]	54	Input	AH14	3.3v	LVC MOS33
Video Data 2 Chroma[5]	56	Input	AH13	3.3v	LVC MOS33
Video Data 2 Chroma[6]	58	Input	AJ14	3.3v	LVC MOS33
Video Data 2 Chroma[7]	60	Input	AJ13	3.3v	LVC MOS33
Video Data 2 Chroma[8]	59	Input	AK13	3.3v	LVC MOS33
Video Data 2 Chroma[9]	61	Input	AK12	3.3v	LVC MOS33
Video Data 3 Chroma[0]	108	Input	AJ26	3.3v	LVC MOS33
Video Data 3 Chroma[1]	110	Input	AK26	3.3v	LVC MOS33
Video Data 3 Chroma[2]	112	Input	AH26	3.3v	LVC MOS33
Video Data 3 Chroma[3]	114	Input	AH27	3.3v	LVC MOS33
Video Data 3 Chroma[4]	136	Input	AK27	3.3v	LVC MOS33
Video Data 3 Chroma[5]	138	Input	AK28	3.3v	LVC MOS33
Video Data 3 Chroma[6]	139	Input	AJ28	3.3v	LVC MOS33
Video Data 3 Chroma[7]	141	Input	AJ29	3.3v	LVC MOS33
Video Data 3 Chroma[8]	140	Input	AJ30	3.3v	LVC MOS33
Video Data 3 Chroma[9]	142	Input	AK30	3.3v	LVC MOS33
SPDIF Audio	27	Input	Y20	1.5v	LVC MOS15
Transport Stream Buffer	29	Input	AA20	1.5v	LVC MOS15
Transport Stream Clock	31	Output	AA18	1.5v	LVC MOS15
Transport Stream Data	33	Output	AA19	1.5v	LVC MOS15
Transport Stream Data [0]	152	Output	AF30	3.3v	LVC MOS33
Transport Stream Data [1]	154	Output	AG30	3.3v	LVC MOS33
Transport Stream Data [2]	158	Output	AE30	3.3v	LVC MOS33
Transport Stream Data [3]	160	Output	AB29	3.3v	LVC MOS33
Transport Stream Data [4]	162	Output	AB30	3.3v	LVC MOS33
Transport Stream Data [5]	164	Output	AA27	3.3v	LVC MOS33
Transport Stream Data [6]	166	Output	AA28	3.3v	LVC MOS33
Transport Stream Data [7]	120	Output	AH28	3.3v	LVC MOS33
Uart_tx	90	Output	AK15	3.3v	LVC MOS33
Uart_rx	88	Input	AJ15	3.3v	LVC MOS33

6.2 Signal Formats

6.2.1 Clock Signals (Input)

The 4k encoder has 4 input clocks, **Video Clock 0** (pin # 63), **Video Clock 1** (pin # 80), **Video Clock 2** (pin # 144), and **Video Clock 3** (pin # 105). These clocks match the four of 3G SDI inputs for one 4k@30/60 video. However, if one 4k input is used on the carrier board, such as HDMI 2.0 or 12G SDI, only **Video Clock 0** is needed which takes the input video clock (74.5MHz for 4k@30, and 148.5 MHz for 4k@60).

6.2.2 Video Data Signals (Input)

The input to the encoder module is raw video data in YUV format (4:2:2 or 4:2:0), with 40 input lines: **Video Data 0 Luma[0]** to **Video Data 3 Luma[9]**, for Luma. And, 40 input lines: **Video Data 0 Chroma[0]** to **Video Data 3**

6.4 Power Requirement and Supply Amperage

The total power, at operation, required by a given encoder module ranges from 3 to 6 watts, depending on the resolution and frame rate. Since the total power is delivered over 6 power rails (1.0v, 1.2v, 1.3v, 1.5v, 2.5v, and 3.3v), each individual power rails deliveries only a portion of the total power. However, the power is not evenly distributed among the rails. Table-7 lists the power estimation by Xilinx Vivado FPGA software for each rail, at 4k@60 resolution, which can be used as a reference for PCB design. It should be noted that the estimated total power showing in Table-7 is higher than the measured real power of the module. However, for PCB design purposes, Table-7 is sufficient. It should also be noted that the power rails 1.8v and 2.0v are generated on the module, by using some of the input power rails. Carrier board PCB designers need not to consider these two rails.

Table-7: Power estimation for the H.264 4k encoder module (4k@60 resolution)

Power Supply				
Supply Source	Voltage (V)	Total (A)	Dynamic (A)	Static (A)
Vccint	1.000	5.462	5.351	0.111
Vccaux	1.800	0.558	0.500	0.058
Vcco33	3.300	0.006	0.005	0.001
Vcco25	2.500	0.000	0.000	0.000
Vcco18	1.800	0.001	0.000	0.001
Vcco15	1.500	0.429	0.428	0.001
Vcco135	1.350	0.000	0.000	0.000
Vcco12	1.200	0.000	0.000	0.000
Vccaux_jo	2.000	0.109	0.109	0.000
Vccbram	1.000	0.083	0.057	0.026
MGTAVcc	1.000	0.000	0.000	0.000
MGTAVtt	1.200	0.000	0.000	0.000
MGTVccaux	1.800	0.000	0.000	0.000
Vccpint	1.000	0.750	0.723	0.027
Vccpaux	1.800	0.061	0.051	0.010
Vccpll	1.800	0.019	0.016	0.003
Vcco_ddr	1.500	0.459	0.457	0.002
Vcco_mio0	1.800	0.007	0.006	0.001
Vcco_mio1	1.800	0.001	0.000	0.001
Vccadc	1.800	0.022	0.002	0.020

Since the encoder module normally shares the power supplies with the carrier board (user PCB). The power design should be considered for both the module and the carrier board. SOC licenses the schematics of carrier boards. The VTR-4000C discussed in Section 12 of this document is for 4k resolution. The reference design provides not only the power system design, but also the I/O port designs, such as SDI, HDMI, Mini-USB, etc. Contact SOC sale at: sales@soctechnologies.com for design licensing information.

12.2 VTR-4000C Evaluation Board

Fig. 12 shows the top view of the VTR-4000C board. Major components and I/O ports are marked in the figure. Refer to the [User Guide of VTR-4000C](#) for further details.

SOC licenses the Schematics of VTR-4000C to the customers that have purchased encoder (or decoder) Modules. Firmware of the VTR-4000C, including I/O drivers and network IP core, is also available for licensing. Please contact SOC sales, sales@soctechnologies.com, for details.

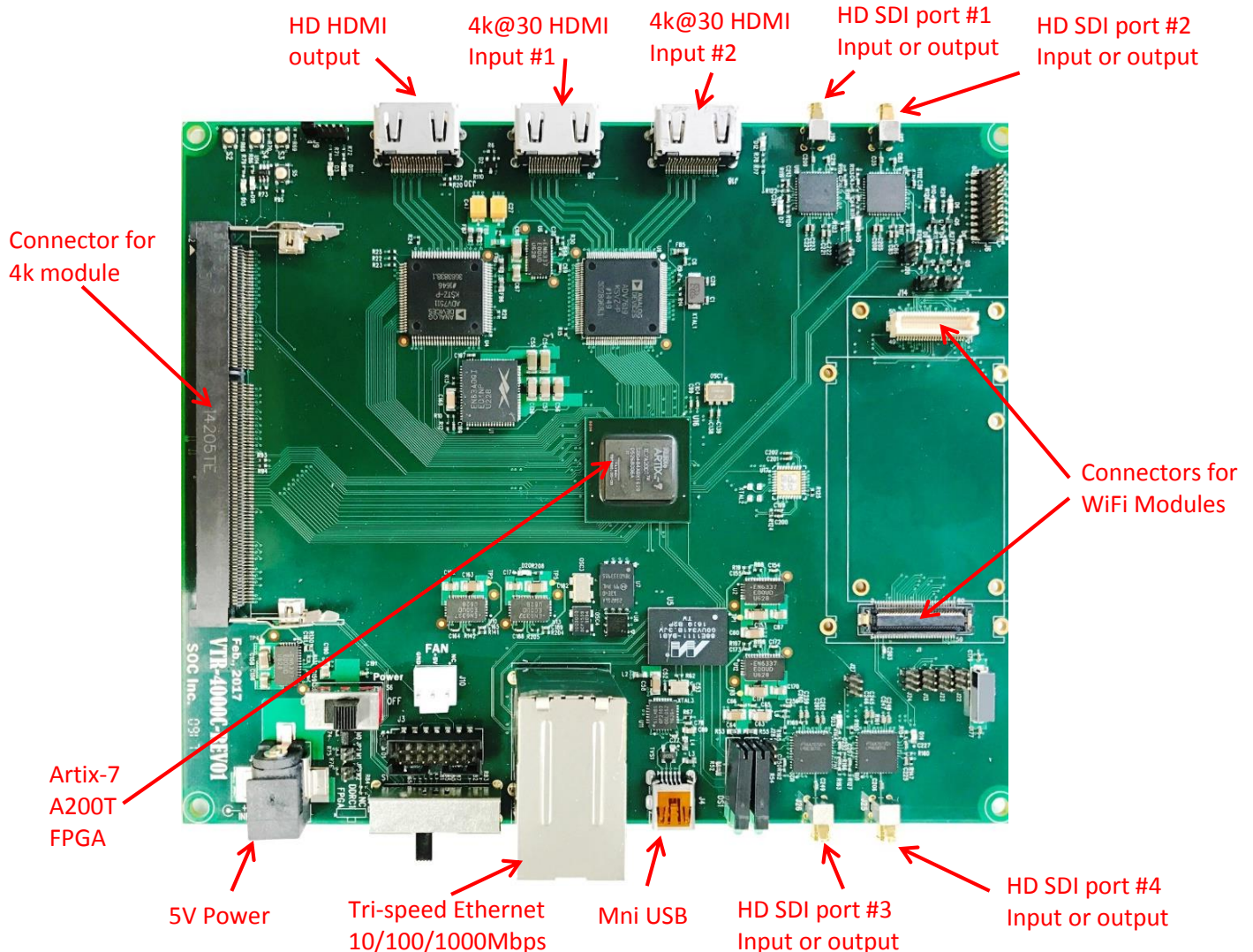

Fig. 12. VTR-4000C evaluation board top view

13. Ordering Information

Fig. 13 shows the product code naming convention for the SOC MPEG codec modules and IP cores. Non-standard codec modules can be ordered following the same naming format (minimum order quantity is required for non-standard modules).

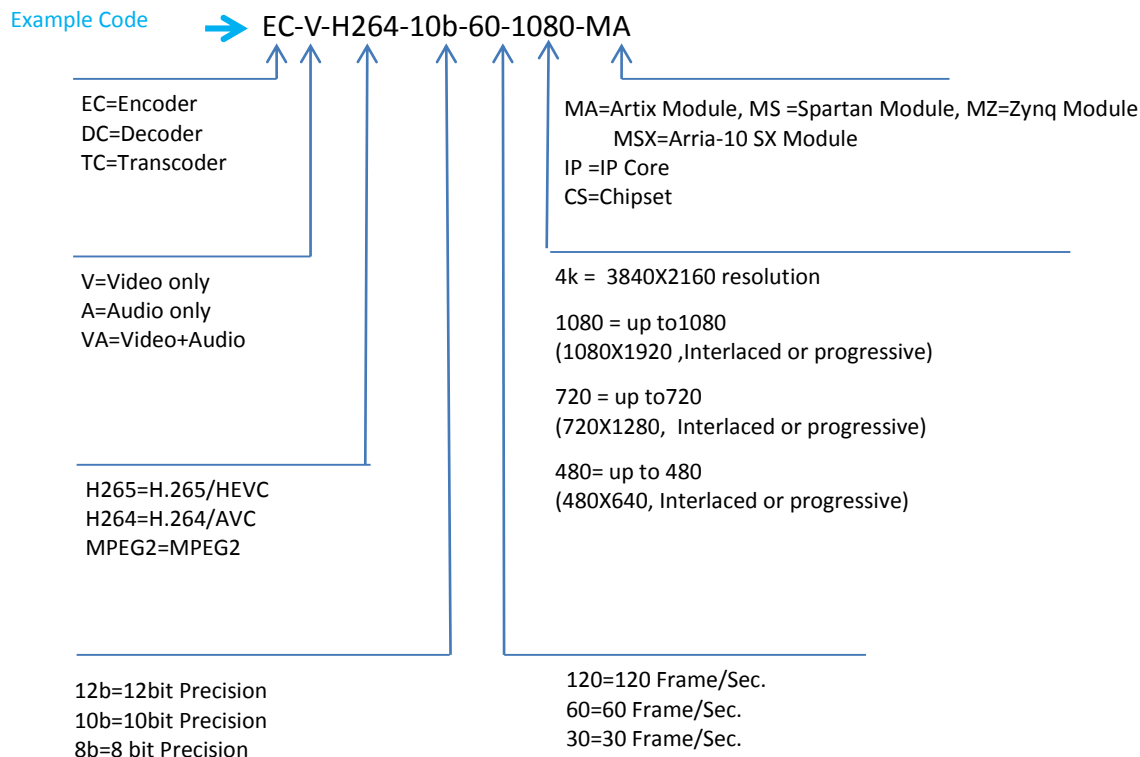

Fig. 13 SOC MPEG codec (IP cores and modules) product code naming convention

14. Contact Information

Please contact SOC head office or distributor for product details and to place an order.

Head Office

System-On-Chip (SOC) Technologies Inc.

60 Baffin Place

Waterloo, ON, Canada N2V 1Z7

Telephone: 1-519-880-8609

E-mail: sales@soctechnologies.com

Table-A4: H.264 Video&Audio Encoder Modules (both video and audio):

Product #	Specifications							Hardware
	Standard	Profile	Resolution	Chroma	Precision	Frame Rate	Audio	
EC-VA-H264-8b-30-720-MS	H.264	up to High	up to 720i/p	4:2:0/4:2:2	8 bits	up to 30fps	AAC/MPEG2 L-2	MCM-1000A
EC-VA-H264-8b-60-720-MS	H.264	up to High	up to 720i/p	4:2:0/4:2:2	8 bits	up to 60fps	AAC/MPEG2 L-2	MCM-1000A
EC-VA-H264-8b-30-1080-MS	H.264	up to High	up to 1080i/p	4:2:0/4:2:2	8 bits	up to 30fps	AAC/MPEG2 L-2	MCM-1000A
EC-VA-H264-10b-30-1080-MS	H.264	up to High	up to 1080i/p	4:2:0/4:2:2	up to 10bits	up to 30fps	AAC/MPEG2 L-2	MCM-1000A
EC-VA-H264-8b-60-1080-MA	H.264	up to High	up to 1080i/p	4:2:0/4:2:2	8 bits	up to 60fps	AAC/MPEG2 L-2	MCM-1000A
EC-VA-H264-10b-60-1080-MA	H.264	up to High	up to 1080i/p	4:2:0/4:2:2	up to 10 bits	up to 60fps	AAC/MPEG2 L-2	MCM-1000A
EC-VA-H264-8b-30-4k-MZ	H.264	High	4kx2k	4:2:0/4:2:2	8 bits	up to 30fps	AAC/MPEG2 L-2	MCM-1000Z
EC-VA-H264-10b-30-4k-MZ	H.264	High	4kx2k	4:2:0/4:2:2	10 bits	up to 30fps	AAC/MPEG2 L-2	MCM-1000Z
EC-VA-H264-8b-60-4k-MZ	H.264	High	4kx2k	4:2:0/4:2:2	8 bits	up to 60fps	AAC/MPEG2 L-2	MCM-1000Z
EC-VA-H264-10b-60-4k-MZ	H.264	High	4kx2k	4:2:0/4:2:2	10 bits	up to 60fps	AAC/MPEG2 L-2	MCM-1000Z

A.3 H.264 Decoder Modules

Hardware platform MCM-1000A is used for the H.264 HD decoders. Table-A5 lists the factory standard H.264 video decoder modules (video only), along with the product code and specifications. Table-A6 lists the factory standard H.264 video and audio decoder modules, product code, specifications.

Table-A5: H.264 Video Decoder Modules (video only without audio):

Product #	Specifications							Hardware
	Standard	Profile	Resolution	Chroma	Precision	Frame Rate	Audio	
DC-V-H264-8b-30-720-MA	H.264	up to High	up to 720i/p	4:2:0/4:2:2	8 bits	up to 30fps	no	MCM-1000A
DC-V-H264-8b-60-720-MA	H.264	up to High	up to 720i/p	4:2:0/4:2:2	8 bits	up to 60fps	no	MCM-1000A
DC-V-H264-8b-30-1080-MA	H.264	up to High	up to 1080i/p	4:2:0/4:2:2	8 bits	up to 30fps	no	MCM-1000A
DC-V-H264-10b-30-1080-MA	H.264	up to High	up to 1080i/p	4:2:0/4:2:2	up to 10 bits	up to 30fps	no	MCM-1000A
DC-V-H264-8b-60-1080-MA	H.264	up to High	up to 1080i/p	4:2:0/4:2:2	8 bits	up to 60fps	no	MCM-1000A
DC-V-H264-10b-60-1080-MA	H.264	up to High	up to 1080i/p	4:2:0/4:2:2	up to 10 bits	up to 60fps	no	MCM-1000A
DC-V-H264-8b-30-4k-MZ	H.264	High	4kx2k	4:2:0/4:2:2	8 bits	up to 30fps	no	MCM-1000Z
DC-V-H264-10b-30-4k-MZ	H.264	High	4kx2k	4:2:0/4:2:2	10 bits	up to 30fps	no	MCM-1000Z
DC-V-H264-8b-60-4k-MZ	H.264	High	4kx2k	4:2:0/4:2:2	8 bits	up to 60fps	no	MCM-1000Z
DC-V-H264-10b-60-4k-MZ	H.264	High	4kx2k	4:2:0/4:2:2	10 bits	up to 60fps	no	MCM-1000Z

Table-A6: H.264 Video&Audio Decoder Modules (both video and audio):

Product #	Specifications							Hardware
	Standard	Profile	Resolution	Chroma	Precision	Frame Rate	Audio	
DC-VA-H264-8b-30-720-MA	H.264	up to High	up to 720i/p	4:2:0/4:2:2	8 bits	up to 30fps	AAC/MPEG2 L-2	MCM-1000A
DC-VA-H264-8b-60-720-MA	H.264	up to High	up to 720i/p	4:2:0/4:2:2	8 bits	up to 60fps	AAC/MPEG2 L-2	MCM-1000A
DC-VA-H264-8b-30-1080-MA	H.264	up to High	up to 1080i/p	4:2:0/4:2:2	8 bits	up to 30fps	AAC/MPEG2 L-2	MCM-1000A
DC-VA-H264-10b-30-1080-MA	H.264	up to High	up to 1080i/p	4:2:0/4:2:2	up to 10 bits	up to 30fps	AAC/MPEG2 L-2	MCM-1000A
DC-VA-H264-8b-60-1080-MA	H.264	up to High	up to 1080i/p	4:2:0/4:2:2	8 bits	up to 60fps	AAC/MPEG2 L-2	MCM-1000A
DC-VA-H264-10b-60-1080-MA	H.264	up to High	up to 1080i/p	4:2:0/4:2:2	up to 10 bits	up to 60fps	AAC/MPEG2 L-2	MCM-1000A
DC-VA-H264-8b-30-4k-MZ	H.264	High	4kx2k	4:2:0/4:2:2	8 bits	up to 30fps	AAC/MPEG2 L-2	MCM-1000Z
DC-VA-H264-10b-30-4k-MZ	H.264	High	4kx2k	4:2:0/4:2:2	10 bits	up to 30fps	AAC/MPEG2 L-2	MCM-1000Z
DC-VA-H264-8b-60-4k-MZ	H.264	High	4kx2k	4:2:0/4:2:2	8 bits	up to 60fps	AAC/MPEG2 L-2	MCM-1000Z
DC-VA-H264-10b-60-4k-MZ	H.264	High	4kx2k	4:2:0/4:2:2	10 bits	up to 60fps	AAC/MPEG2 L-2 L	MCM-1000Z

A.4 MPEG-2 Encoder Modules

Table-A7 lists the standard MPEG-2 video encoder modules. Table-A8 lists the MPEG-2 video/audio encoder modules. The 8-bit precision and 60 frames/second modules are offered as extensions of the MPEG-2 standard.

Table-A7: MPEG-2 Video Encoder Module (video only without audio):

Product #	Specifications							Hardware
	Standard	Profile	Resolution	Chroma	Precision	Frame Rate	Audio	
EC-V-MPEG2-8b-30-720-MA	MPEG-2	up to High	up to 720i/p	4:2:0/4:2:2	8 bits	up to 30fps	no	MCM-1000A
EC-V-MPEG2-8b-60-720-MA	MPEG-2	up to High	up to 720i/p	4:2:0/4:2:2	8 bits	up to 60fps	no	MCM-1000A
EC-V-MPEG2-8b-30-1080-MA	MPEG-2	up to High	up to 1080i/p	4:2:0/4:2:2	8 bits	up to 30fps	no	MCM-1000A
EC-V-MPEG2-8b-60-1080-MA	MPEG-2	up to High	up to 1080i/p	4:2:0/4:2:2	8 bits	up to 60fps	no	MCM-1000A

Table-A8: MPEG-2 Video&Audio Encoder Modules (both video and audio):

Product #	Specifications							Hardware
	Standard	Profile	Resolution	Chroma	Precision	Frame Rate	Audio	
EC-VA-MPEG2-8b-30-720-MA	MPEG-2	up to High	up to 720i/p	4:2:0/4:2:2	8 bits	up to 30fps	AAC/MPEG2 L-2	MCM-1000A
EC-VA-MPEG2-8b-60-720-MA	MPEG-2	up to High	up to 720i/p	4:2:0/4:2:2	8 bits	up to 60fps	AAC/MPEG2 L-2	MCM-1000A
EC-VA-MPEG2-8b-30-1080-MA	MPEG-2	up to High	up to 1080i/p	4:2:0/4:2:2	8 bits	up to 30fps	AAC/MPEG2 L-2	MCM-1000A
EC-VA-MPEG2-8b-60-1080-MA	MPEG-2	up to High	up to 1080i/p	4:2:0/4:2:2	8 bits	up to 60fps	AAC/MPEG2 L-2	MCM-1000A

A.5 MPEG-2 Decoder Modules

Table-A9 lists the standard MPEG-2 video decoder modules. Table-A10 lists the MPEG-2 video/audio decoder modules. The 10-bit precision and 60 frames/second modules are offered as extensions of the MPEG-2 standard.

Table-A9: MPEG-2 Video Decoder Modules (video only without audio):

Product #	Specifications							Hardware
	Standard	Profile	Resolution	Chroma	Precision	Frame Rate	Audio	
DC-V-MPEG2-8b-30-720-MS	MPEG-2	up to High	up to 720i/p	4:2:0/4:2:2	8 bits	up to 30fps	no	MCM-1000S
DC-V-MPEG2-8b-60-720-MA	MPEG-2	up to High	up to 720i/p	4:2:0/4:2:2	8 bits	up to 60fps	no	MCM-1000A
DC-V-MPEG2-8b-30-1080-MS	MPEG-2	up to High	up to 1080i/p	4:2:0/4:2:2	8 bits	up to 30fps	no	MCM-1000S
DC-V-MPEG2-8b-60-1080-MA	MPEG-2	up to High	up to 1080i/p	4:2:0/4:2:2	8 bits	up to 60fps	no	MCM-1000A

Table-A10: MPEG-2 Video&Audio Decoder Modules (both video and audio):

Product #	Specifications							Hardware
	Standard	Profile	Resolution	Chroma	Precision	Frame Rate	Audio	
DC-V-MPEG2-8b-30-720-MS	MPEG-2	up to High	up to 720i/p	4:2:0/4:2:2	8 bits	up to 30fps	AAC/MPEG2 L-2	MCM-1000S
DC-V-MPEG2-8b-60-720-MA	MPEG-2	up to High	up to 720i/p	4:2:0/4:2:2	8 bits	up to 60fps	AAC/MPEG2 L-2	MCM-1000A
DC-V-MPEG2-8b-30-1080-MS	MPEG-2	up to High	up to 1080i/p	4:2:0/4:2:2	8 bits	up to 30fps	AAC/MPEG2 L-2	MCM-1000S
DC-V-MPEG2-8b-60-1080-MA	MPEG-2	up to High	up to 1080i/p	4:2:0/4:2:2	8 bits	up to 60fps	AAC/MPEG2 L-2	MCM-1000A

A.6 H.264-to-H.265 Transcoder Modules

Table-A11 lists the standard H.264-to-H.265 video transcoder modules. Table-A12 lists the H.264-to-H.265 video/audio transcoder modules.

Table-A11: H.264-to-H.265 Video Transcoder Modules (video only without audio):

Product #	Specifications							Hardware
	Standard	Profile	Resolution	Chroma	Precision	Frame Rate	Audio	
TC-V-H.264-to-H.265-8b-30-720-MZ	H.265	Main 4:2:2	up to 720i/p	up to 4:2:2	8 bits	up to 30fps	no	MCM-1000Z
TC-V-H.264-to-H.265-10b-30-720-MZ	H.265	Main 4:2:2	up to 720i/p	up to 4:2:2	10 bits	up to 30fps	no	MCM-1000Z
TC-V-H.264-to-H.265-8b-60-720-MZ	H.265	Main 4:2:2	up to 720i/p	up to 4:2:2	8 bits	up to 60fps	no	MCM-1000Z
TC-V-H.264-to-H.265-10b-60-720-MZ	H.265	Main 4:2:2	up to 720i/p	up to 4:2:2	10 bits	up to 60fps	no	MCM-1000Z
TC-V-H.264-to-H.265-8b-30-1080-MZ	H.265	Main 4:2:2	up to 1080i/p	up to 4:2:2	8 bits	up to 30fps	no	MCM-1000Z
TC-V-H.264-to-H.265-10b-30-1080-MZ	H.265	Main 4:2:2	up to 1080i/p	up to 4:2:2	10 bits	up to 30fps	no	MCM-1000Z
TC-V-H.264-to-H.265-8b-60-1080-MZ	H.265	Main 4:2:2	up to 1080i/p	up to 4:2:2	8 bits	up to 60fps	no	MCM-1000Z
TC-V-H.264-to-H.265-10b-60-1080-MZ	H.265	Main 4:2:2	up to 1080i/p	up to 4:2:2	10 bits	up to 60fps	no	MCM-1000Z

A.8 MPEG2-to-H.264 Transcoder Modules

Table-A15 lists the standard MPEG2-to-H.264 video transcoder modules, and Table-A16 lists the MPEG2-to-H.264 video/audio transcoder modules. The 60frames/second modules are offered as extensions of the MPEG-2 standard.

Table-A15: MPEG2-to-H.264 Video Transcoder Modules (video only without audio):

Product #	Specifications							Hardware
	Standard	Profile	Resolution	Chroma	Precision	Frame Rate	Audio	
TC-V-MPEG2-to-H.264-8b-30-720-MA	MPEG2	High	up to 720i/p	up to 4:2:2	8 bits	up to 30fps	no	MCM-1000A
TC-V-MPEG2-to-H.264-8b-60-720-MA	MPEG2	High	up to 720i/p	up to 4:2:2	8 bits	up to 60fps	no	MCM-1000A
TC-V-MPEG2-to-H.264-8b-30-1080-MA	MPEG2	High	up to 1080i/p	up to 4:2:2	8 bits	up to 30fps	no	MCM-1000A
TC-V-MPEG2-to-H.264-8b-60-1080-MA	MPEG2	High	up to 1080i/p	up to 4:2:2	8 bits	up to 60fps	no	MCM-1000A

Table-A16: MPEG2-to-H.264 Video&Audio Transcoder Modules (both video and audio):

Product #	Specifications							Hardware
	Standard	Profile	Resolution	Chroma	Precision	Frame Rate	Audio	
TC-VA-MPEG2-to-H.264-8b-30-720-MA	MPEG2	High	up to 720i/p	up to 4:2:2	8 bits	up to 30fps	MPEG2-L2/AAC	MCM-1000A
TC-VA-MPEG2-to-H.264-8b-60-720-MA	MPEG2	High	up to 720i/p	up to 4:2:2	8 bits	up to 60fps	MPEG2-L2/AAC	MCM-1000A
TC-VA-MPEG2-to-H.264-8b-30-1080-MA	MPEG2	High	up to 1080i/p	up to 4:2:2	8 bits	up to 30fps	MPEG2-L2/AAC	MCM-1000A
TC-VA-MPEG2-to-H.264-8b-60-1080-MA	MPEG2	High	up to 1080i/p	up to 4:2:2	8 bits	up to 60fps	MPEG2-L2/AAC	MCM-1000A

A.9 Non-Standard Codec Modules

The previous section provides the information on SOC's factory standard MPEG codec modules. Customers can order modules based on customer specific requirements (non-standard modules). There is a Minimum Order Quantity (MOQ) required for customized configurations. Contact SOC sales sale@soctechologies.com for information.

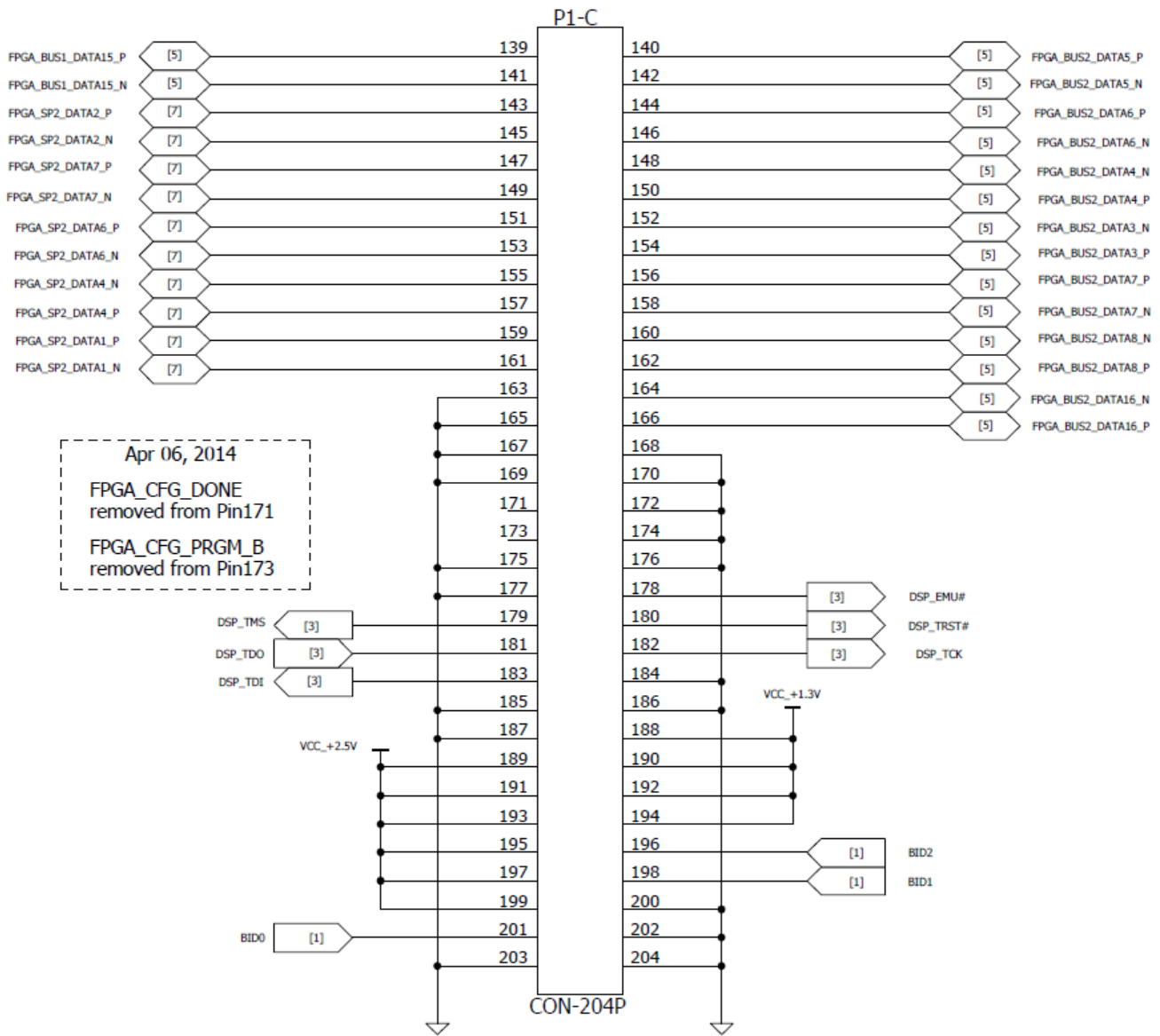

Appendix - C MCM-1000Z Edge Connector Schematics

