



Welcome to E-XFL.COM

Understanding [Embedded - Microcontroller, Microprocessor, FPGA Modules](#)

Embedded - Microcontroller, Microprocessor, and FPGA Modules are fundamental components in modern electronic systems, offering a wide range of functionalities and capabilities. Microcontrollers are compact integrated circuits designed to execute specific control tasks within an embedded system. They typically include a processor, memory, and input/output peripherals on a single chip. Microprocessors, on the other hand, are more powerful processing units used in complex computing tasks, often requiring external memory and peripherals. FPGAs (Field Programmable Gate Arrays) are highly flexible devices that can be configured by the user to perform specific logic functions, making them invaluable in applications requiring customization and adaptability.

Applications of [Embedded - Microcontroller,](#)

Details

Product Status	Obsolete
Module/Board Type	MPU Core
Core Processor	ARM7TDMI, NS7520
Co-Processor	-
Speed	55MHz
Flash Size	4MB
RAM Size	8MB
Connector Type	Pin Header
Size / Dimension	1.94" x 1.58" (49.2mm x 40.0mm)
Operating Temperature	-40°C ~ 85°C
Purchase URL	https://www.e-xfl.com/product-detail/digi-international/dc-em-02t-ns-25

Digi Connect EM[®] Family

Wired and Wireless Embedded Modules

The industry's first interchangeable secure device server module, delivering wired and wireless Ethernet network connectivity that is cost-effective and easy to implement.

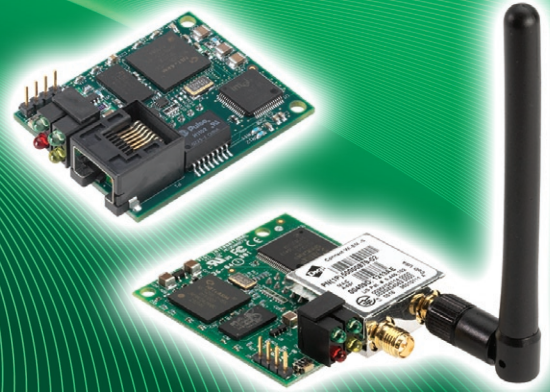

Overview

Based on a common platform design approach, the Digi Connect EM and Digi Connect[®] Wi-EM offer complete drop-in integration combined with true long-term product availability. This allows you to build future-proof products based on single design by simply selecting between the 10/100 wired and 802.11b module. The Digi Connect EM family makes this possible without the traditional complexities of hardware and software integration work, and at a fraction of the time and cost required to create custom solutions.

Built on Digi's leading 32-bit NET+ARM processor technology, the Digi Connect EM family offers two-port serial-to-Ethernet functionality through Digi's plug-and-play firmware, and the freedom and flexibility of professional embedded software development provided by the easy-to-use, cost-effective and complete Digi JumpStart Kits[®] for NET+OS[®].

Block Diagram

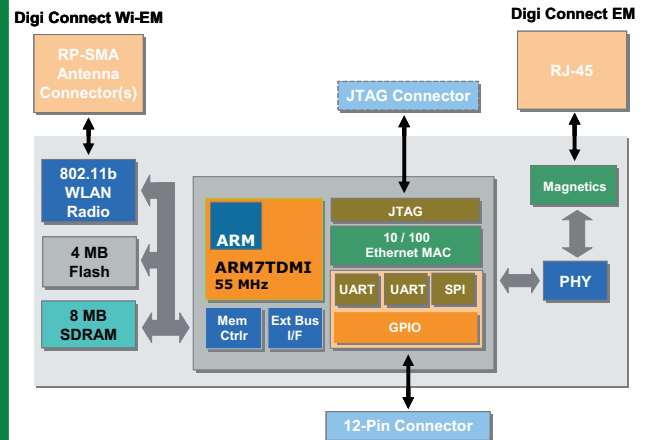

Features/Benefits

- Compact and secure 32-bit device server modules
- Family of low-profile and pin-compatible modules
- 10/100 Ethernet interface or 802.11b WLAN interface
- 2 UART ports and integrated SPI option
- Strong WPA2/802.11i security (PSK and Enterprise)
- Proven low-emission design (FCC Class B)
- Extended/industrial operating temperature
- Digi processor and WLAN technology for true long-term availability
- Seamless migration path to NET+ARM chip design

Platforms and Services



Design Services



Accessory Kits



Support

NET + OS

PLUG -and- PLAY
FIRMWARE

Supported Software Platforms



Integration Kits / Development Kits

Integration Kit and Digi JumpStart Kit®: Overview

Plug-and-Play Integration Kit

Digi Integration Kits provide everything needed for evaluation, rapid prototyping and integration of Digi Connect device server modules using the feature-rich Digi plug-and-play device server firmware. They deliver fully transparent wired and wireless serial-to-network functionality and allow you to quickly network-enable your existing and new product designs.

Digi plug-and-play firmware offers industry-leading features such as a robust IPv6-ready TCP/IP stack, fully-featured serial tunneling, Modbus/TCP, web user interface with private labeling/branding options, user management, file system, SSL/TLS, SSH, Modbus/TCP, intelligent device management via SNMP, configurable e-mail alarms, and patented RealPort® COM/TTY port redirection.

- Complete kit for product evaluation, rapid prototyping, and integration
- Digi plug-and-play firmware eliminates embedded software development
- Transparent wired and wireless device server functionality
- Full private-labeling/branding supported out-of-the-box



Digi JumpStart Kit® for NET+OS®

This royalty-free turnkey solution for embedded software development is based on the ThreadX Real-Time Operating System (RTOS), one of the most reliable and field-proven RTOS solutions available. In addition to ThreadX, NET+OS provides the integrated building blocks needed to create product solutions with leading network security using Digi embedded modules and microprocessors.

For professional NET+OS software development, the Microsoft Windows based Digi ESP™ Integrated Development Environment (IDE), with graphical user interface and a high-speed USB 2.0 hardware debugger, is provided out-of-the-box.

- Royalty-free turnkey solution for embedded software development
- Built on field-proven and compact ThreadX RTOS
- Fully integrated support for secure, IPv4/IPv6 networking applications
- Professional software development using Windows-based Digi ESP IDE



Application Kit and Digi JumpStart Kit® Contents

Software Platform	Plug-and-Play Firmware	NET+OS®
Module	Digi Connect EM or Digi Connect Wi-EM module w/ 4 MB Flash, 8 MB SDRAM, 2 dBi dipole antenna (Digi Connect Wi-EM)	
Development Board	2 RS-232 serial ports, GPIO configuration/test switches (hi/lo), Screw terminal for GPIO signals, Status LEDs (serial, GPIO, power), Logic signal header, Test points, Reset button, 9-30VDC power supply w/Power-over-Ethernet support (mid-span), SPI header, JTAG header (JTAG modules)	
CD/DVD	Digi Connect Integration Kit CD: Device discovery tool w/source code, Device configuration wizard w/source code, RCI library, Device discovery (ADDP) library, Java applet sample source code, C/C++ sample source code (TCP, UDP, SSL)	Digi NET+OS CD: NET+OS 7, Digi ESP IDE, BSP source code, Sample code, Green Hills MULTI IDE support files, User documentation
Documentation	Getting started, Hardware reference manual, Development board schematics Digi Connect user's guide, Command line reference, RCI specification	Quick start guide, Getting started guide, Hardware reference manual, Development board schematics
Power Supply	External wall power supply (110/240VAC to 12VDC @ 850 mA) with interchangeable outlet adapters (North America, EU, UK, and Australia)	
Accessories	Crossover serial cable, Ethernet cable or 2 dBi dipole antenna	
Other	—	Digi JTAG link USB 2.0 hardware debugger
Kit Part Numbers		
Ethernet Only	DC-EM-KT	DC-EM-NET
802.11b WLAN + Ethernet	DC-WEM-KT	DC-WEM-NET

Please refer to the feature specs on our website for detailed information about the specific software platform capabilities.

Platform

Digi Connect EM®

Digi Connect® Wi-EM

Hardware		
Processor Type	32-bit Digi NS7520 processor	
ARM Core	ARM7TDMI	
Processor Speed	55 MHz	
Memory Base Population	4 MB NOR flash	
	8 MB SDRAM	
Population Options	LED array, LED pin header, Ethernet (RJ-45) connector, Ethernet pin header, Antenna connectors	
Pins/Form Factor	PCB-style module with 12-pin main pin header	
High-Speed TTL Serial Interface	2 with up to 230 Kbps data rate	
	First port with full signal support for TXD, RXD, RTS, CTS, DTR, DSR and DCD, including hardware/software flow control Second port RXD/TXD only	
GPIO	9 shared	
SPI	Master mode (Available through NET+OS development kit only)	
On-Board Power Supervisor	•	
JTAG Interface	NET+OS development modules only (P/N DC-EM-02T-JT, DC-WEM-02T-JT)	
Dimensions (L x W x H)	1.935 in (49.149 mm) x 1.575 in (40.005 mm) x 0.670 in (17.018 mm) Height and width (overhang) varies depending on connector population. See hardware reference manual for additional information.	1.935 in (49.149 mm) x 1.855" (47.117 mm) x 0.0653" (16.586 mm) Height and width (overhang) varies depending on connector population. See hardware reference manual for additional information.
Network Interface - Wired		
Standard	IEEE 802.3	-
Physical Layer	10/100Base-T	-
Data Rate	10/100 Mbps (auto-sensing)	-
Mode	Full- or half-duplex (auto-sensing)	-
Connector	RJ-45 or Pin Header	-
Integrated Ethernet MAC/PHY	•	-
Network Interface – Wireless LAN		
Standard	-	IEEE 802.11b
Frequency	-	2.4 GHz
Data Rate	-	Up to 11 Mbps with fallback
Modulation	-	DBPSK (1 Mbps), DQPSK (2 Mbps), CCK (11,5.5 Mbps)
Typical Transmit Power	-	16 dBm
Receive Sensitivity	-	-82 dBm @ 11 Mbps
Connector	-	1/2 x RP-SMA
WLAN Security		
WEP (Wired Equivalent Privacy)	-	64/128-bit encryption (RC4)
WPA/WPA2/802.11i	-	128-bit TKIP/CCMP (AES) encryption Enterprise mode (802.1X); LEAP (WEP only), PEAP, TTLS, TLS; GTC, MD5, OTP, PAP, CHAP, MSCHAP, MSCHAPv2, TTLS; MSCHAPv2

• Module Feature

Platform	Digi Connect EM®	Digi Connect® Wi-EM
Environmental		
Operating Temperature	-40° C to +85° C (-40° F to +185° F)	-30° C to +85° C (-22° F to +185° F)
Storage Temperature	-50° C to +125° C (-58° F to +257° F)	
Relative Humidity	5% to 90% (non-condensing)	
Altitude	12,000 feet (3,658 meters)	
Power Requirements @3.3VDC		
Maximum	270 mA (891 mW)	400 mA (1.32 W)
Regulatory Approvals		
FCC Part 15 Class B, EN 55022 Class B		•
EN 61000-3-2 and EN 61000-3-3		•
ICES-003 Class B, VCCI Class II, AS 3548		•
FCC Part 15 Sub C Section 15.247		•
IC RSS-210 Issue 5 Section 6.2.2(o)		•
EN 300 328, EN 301 489-17		•
UL 60950-1, EN 60950 (EU)		•
CSA C22.2, No. 60950		•
EN 55024		•

• Module Feature

Digi Connect EM® - Front

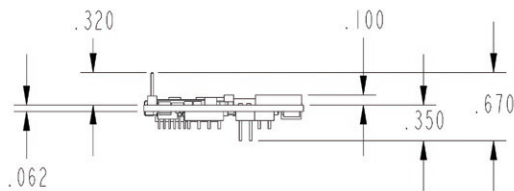

Digi Connect® Wi-EM - Front

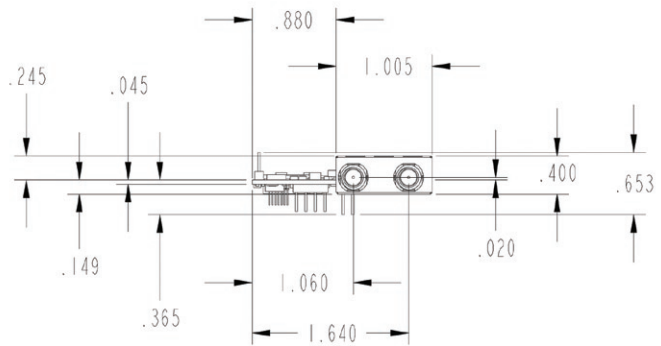

Visit www.digiembedded.com for part numbers.

DIGI SERVICE AND SUPPORT - You can purchase with confidence knowing that Digi is here to support you with expert technical support and a strong five-year warranty. www.digi.com/support

Digi International
877-912-3444
952-912-3444
info@digi.com

Digi International France
+33-1-55-61-98-98
www.digi.fr

Digi International KK
+81-3-5428-0261
www.digi-intl.co.jp

Digi International (HK) Limited
+852-2833-1008
www.digi.cn

BUY ONLINE • www.digiembedded.com



91001257
D1/609

© 2004-2009 Digi International Inc. All rights reserved. Digi, Digi International, the Digi logo, the When Reliability Matters logo, Digi Connect, Digi Connect EM, Digi JumpStart Kit, NET+ and NET+OS are trademarks or registered trademarks of Digi International Inc. in the United States and other countries worldwide. ARM and NET+ARM are trademarks or registered trademarks of ARM Limited. All other trademarks are the property of their respective owners.

