



Welcome to [E-XFL.COM](http://E-XFL.COM)

#### Understanding [Embedded - Microcontroller, Microprocessor, FPGA Modules](#)

Embedded - Microcontroller, Microprocessor, and FPGA Modules are fundamental components in modern electronic systems, offering a wide range of functionalities and capabilities. Microcontrollers are compact integrated circuits designed to execute specific control tasks within an embedded system. They typically include a processor, memory, and input/output peripherals on a single chip. Microprocessors, on the other hand, are more powerful processing units used in complex computing tasks, often requiring external memory and peripherals. FPGAs (Field Programmable Gate Arrays) are highly flexible devices that can be configured by the user to perform specific logic functions, making them invaluable in applications requiring customization and adaptability.

#### Applications of [Embedded - Microcontroller,](#)

#### Details

Product Status	Obsolete
Module/Board Type	MPU Core
Core Processor	DSTni-EX
Co-Processor	XPort AR
Speed	120MHz
Flash Size	4MB
RAM Size	1.25MB
Connector Type	RJ45
Size / Dimension	0.65" x 1.8" (16.5mm x 45.7mm)
Operating Temperature	-40°C ~ 85°C
Purchase URL	<a href="https://www.e-xfl.com/product-detail/maestro-wireless/xp3002000-01r">https://www.e-xfl.com/product-detail/maestro-wireless/xp3002000-01r</a>



## XPort AR Embedded Processor Module

- ▶ A fully programmable device computing platform based on corporate IT standards – Cisco®-like CLI, XML, RSS
- ▶ Web-enable up to three electronic devices, quickly and easily
- ▶ Provide robust “data center grade” security, including SSL and SSH, for all networked devices
- ▶ Offer true IEEE 802.3af compliant pass-through Power over Ethernet (PoE)

**XPort**<sup>®</sup>  
AR ARCHITECT

## The Flexible, Programmable Device Computing Platform for Building Intelligent, Highly Secure and Network-ready Devices

The size of a few sugar cubes, XPort® Architect™ (AR) is the first device server solution that goes beyond simple network connectivity to deliver an enterprise-grade, programmable device computing and networking platform.

This Embedded Processor Module builds on our proven XPort serial-to-Ethernet/IP technology that enables device manufacturers to add Ethernet or IP connectivity as a standard feature to their products.

XPort AR includes all the essential device computing and networking features built into a single RJ45 package – including a 120Mhz DSTni™ processor, 10/100 Base-T/TX Ethernet connection, an embedded web server and a full network operating system, including TCP/IP protocol stack.

Featuring **Evolution OS™**, our powerful, real-time embedded Networking Operating System, XPort AR now offers the ability to deliver an unprecedented level of intelligence to run a networked device. And with new Evolution 3.0, it's even more robust. It features an extensible, open standards-based software platform for managing the device and delivering information over the enterprise network with “data-center” grade security – including SSH and SSL support. The XPort AR also delivers IEEE 802.3af compliant pass-through Power over Ethernet (PoE).

### A New Era of Machine Intelligence *Enabling Scalable, Intelligent and Autonomous Devices*

As more devices are added to the network, it is increasingly necessary that they are equipped with a certain level of intelligence so they can operate more autonomously. It is not cost-effective or practical to have humans monitoring all of the “edge” equipment on M2M and enterprise networks.

To make this “edge to enterprise” network a reality, the M2M devices need to operate with the same standards as traditional networking equipment found in the IT data center such as servers, routers and switches.

XPort AR with Evolution OS embedded processor module offers standards-based device computing and networking capability. It makes the M2M network scalable by adding an unprecedented level of device intelligence and policy making at the network edge. XPort AR is essentially an “IP computer” built into the device which provides the ability to gather, process and communicate information and then take the appropriate pre-programmed actions. More than just a networking co-processor, it offers:

- A powerful 120 MHz processor
- Two serial data ports and one console port
- 11 configurable GPIO pins
- 230 Kbps serial data rate
- 1.25 MB of SRAM and 4 MB Flash





# LANTRONIX® EVOLUTION OS™

## Machine2Mainstream™

### Integrating Machines and Corporate IT Systems

The benefits of integrating 'edge' M2M networked devices into traditional corporate or enterprise network are tremendous.

A unified corporate and M2M network reduces operations costs by more effectively leveraging IT investments. Additionally, this integration differentiates a company's product or service with increased or added value and helps facilitate opportunities such as:

- Asset tracking/accounting (Sarbanes-Oxley compliance)
- Workflow improvement/monitoring/reporting
- Proactive maintenance services
- Preemptive diagnosis
- Fulfillment services

Network-enabled devices increase profits over the lifecycle of equipment, enabling companies to make better use of the most important asset afforded by the networked equipment: the data gathered and information gleaned.

## Open Standards; Extensible Technologies

As IT managers are increasingly being asked to integrate M2M edge-networked devices at a corporate level, it is important that the tools, technology and architecture on those edge devices meet current data center equipment standards. It is also important that they are easy to integrate and built on extensible and open software technologies.

The Evolution OS Networking Operating System features key integration capabilities including:

- Cisco-like CLI configurability
- XML data transport and configurability
- RSS information feeds



New Evolution 3.0 delivers:

- AJAX based web manager and HTTP server
- Support for compressed firmware images
  - Allows larger, more complex SDK applications to be written
- SNMP v2c agent with
  - MIBII Support
  - RS232 MIB using SDK
  - Ability to create custom MIB in SDK
- New faster, lightweight kernel
- Flash wear leveling and erase cycle statistics
- PPP works with Windows, Linux, BSD
- Syslog support
- New Software Development Kit (SDK) that exposes more modules

### Cisco-like CLI

Making the edge-to-enterprise vision a reality, XPort AR with Evolution OS uses industry-standard tools for configuration, communication and control. It uses Cisco-like command line interface (CLI) with syntax similar to that used by data center equipment such as routers and hubs.

### XML-based Architecture and Device Control

A fundamental building block for the future growth of M2M networks, XML is a standard tool for web services, data transfer and rich content management that encapsulates data into a text-based format. XML-based configuration and setup records in XPort AR make the device configuration transparent to users and administrators and easy to edit with a standard text or XML editor. (Microsoft®, for example, already incorporates XML capabilities into the Office software suite.)

### RSS

RSS is a rapidly emerging technology used to stream and manage on-line content. RSS support enables users to configure the XPort AR to automatically send back real-time device information over the network to a database. More powerful than simple email alerts, RSS uses XML as an underlying transport and adds intelligence to the networked device while not taxing already overloaded email systems. XPort AR also supports standard SMTP email.

### PoE (Power over Ethernet)

XPort AR is the first device server to deliver true IEEE 802.3af compliant pass-through Power over Ethernet (PoE) to edge devices using both Ethernet pairs. Eliminating the need for an external power supply and associated electrician labor costs, XPort AR is ideally suited to add networking functionality in security control, medical, financial, energy metering and building automation applications.

## Enterprise-grade Security

Without the need to disable any features or functionality, Evolution's hardened OS provides XPort AR the highest level of security possible. This 'data center grade' protection ensures that each device on the M2M network carries the same level of security as traditional IT networking equipment.

With built in SSH and SSL, XPort AR has robust defenses to hostile Internet attacks such as denial of service (DoS) and port mapping that can be used to take down the network. XPort AR also cannot be used to bring down other devices on the network. SSH includes powerful key management algorithms that:

- Verify the data received came from the proper source
- Validate that the data transferred from the source over the network is unchanged when it arrives at its destination (shared secret and hashing)
- Provide the ability to run popular M2M protocols over a secure SSH connection

The XPort AR supports a variety of popular cipher technologies including AES, 3DES and RC4 and hashing algorithms such as SHA-1 and MD5. Additionally, SSL ensures secure web-based communications.

## Ease of Use and Flexibility

XPort AR is ideal for companies where networking is not a core competency. The network-enabled programmable module allows designers to focus their attention on code and hardware that serve to differentiate their product.

Accelerating the OEM development process and reducing associated cost, XPort AR features built-in manufacturing testing. With pre-loaded tests, engineers do not need to create them or load them individually. This can dramatically slash development time. The new hardware also features the flexibility of external interrupts (including one non-maskable) and timer input.



## XPort AR with Evolution

### Example Applications

- Real-time asset tracking
  - Integration with enterprise ERP
- Secure metering
  - SSH
- Networked PoE Access Control
  - Save power supply and installation costs
- POS Transaction Automation Terminal
  - Central processor managing system and I/O

## XPort and XPort AR Family of Applications

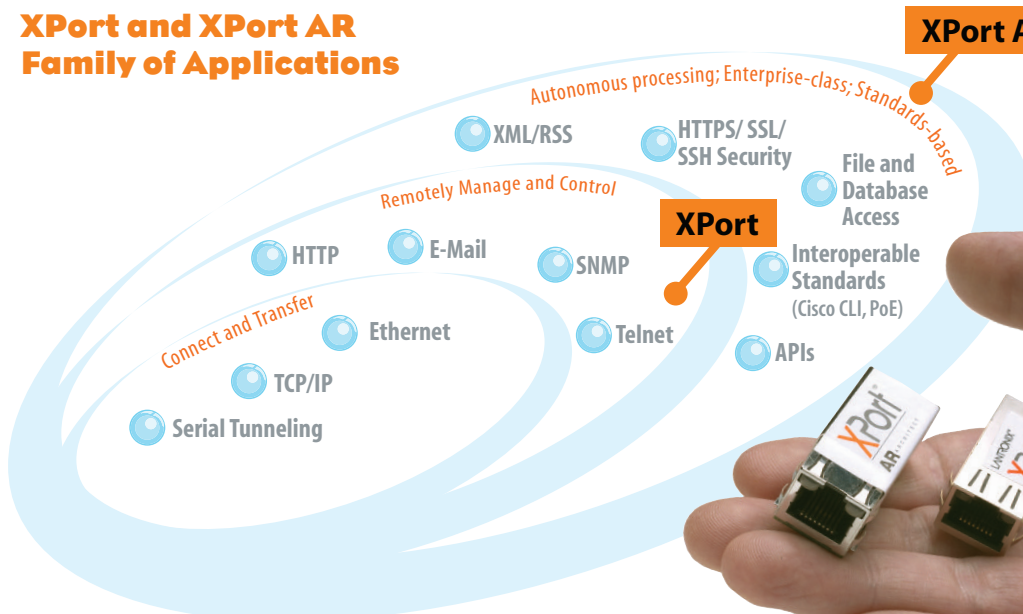

## XPort AR + Evolution



XPort is an extremely fast solution for serial-to-Ethernet data tunneling. The new XPort AR embedded processor adds advanced computing and Machine2Mainstream communication capabilities.

# LANTRONIX<sup>®</sup> EVOLUTION OS<sup>™</sup>

## Evolution Architecture

APPLICATIONS	TUNNELING	COMMAND & CONTROL	3rd PARTY
APPLICATIONS SUPPORT	WEB MANAGER FILE SYSTEM	XML GPIO MANAGER	RSS CONFIGURATION STORE SMTP Email CFG LOGGING CISCO CLI
SECURITY	SSH SHA-1 MD5	SSL 3DES AES RC4	PACKET FILTER PAP CHAP
NETWORK	UDP TCP IP	CGI DNS ICMP PPP ARP AUTO-IP HDLC	RS232 MIB MIB II DISCOVERY FTP TFTP BOOTP
DRIVERS	MANUFACTURING TESTS ETHERNET	WATCH DOG SERIAL LINES	EEPROM FLASH DRIVER PIO (CP) DRIVER
KERNEL	THREADING MODULE PREEMPTIVE SCHEDULER	BUFFER POOLS MEMORY (HEAP) MODULE	SEMAPHORES TIMERS MUTUAL EXCLUSIONS

## Features and Specifications

### Architecture

**CPU:** Based on the DSTni-EX enhanced 16-bit, 120MHz x86 Architecture  
**Memory:** 1.25 MB RAM and 4 MB Flash  
**Firmware:** upgradeable via FTP, TFTP, Serial Ports, Internal Web Server  
**Diagnostics:** Built in diagnostics and comprehensive statistics

### Network Interface

**Interface:** Ethernet 10Base-T or 100Base-TX (Auto-Sensing)  
**Connector:** RJ45  
**Layer 3 Protocols:** TCP, UDP, IP, ARP, ICMP, SSH, SSL, XML, HTTP, PPP, PAP, CHAP, DNS, SMTP, RSS, DHCP, BOOTP, AutoIP, SNMP, FTP, TFTP, Telnet, CGI

### Serial Interface - up to three

**Interface:** CMOS (Asynchronous, 5V tolerant)  
**Data Rates:** 300 bps to 230,400 bps (selectable by 1 bps increments)  
**Characters:** 7 or 8 data bits  
**Parity:** Odd, even, none  
**Stop Bits:** 1 or 2  
**Control Signals:** RTS, CTS, DSR, any PIO  
**Flow Control:** XON/XOFF, RTS/CTS, User-Selectable Characters

### Indicators (LED)

10 or 100 Base-T, Full/Half-Duplex  
 Link & Activity Indicator

### Operating System

RTOS Kernel with pre-emptive scheduler, multithreading, memory management semaphores and Flash file system

### Management

Cisco-CLI, Internal Web Server, XML, Serial, Telnet, SSH, SSL, RSS, SNMP  
 Microsoft Windows<sup>®</sup>-based utility for configuration

### Security

SSH Client & Server, SSL, AES 128-bit encryption, Public/Private-keys, and Password Protection  
 SHA-1, MD5 Hashing Algorithms  
 Base-64 & Digest Authentication  
 User Access Lists  
 Hardened OS and Protocol Stacks

### Internal Web Server

Fully Brandable  
 1.25 MB internal directory-/file-based file system  
 CGI/CSS based  
 SSL supported

### Power

Input Voltage: 3.3 VDC

### Environmental

**Extended Temp:** -40° to 85°C (-40° to 185°F)  
**Storage:** -40° to 85°C (-40° to 185°F)

### Packaging

**Dimensions:** 45.7 x 16.51 x 17.8 mm (1.80 x .65 x .70 in)  
**Weight:** 20 g (0.7 oz)

### Warranty

2-year limited warranty

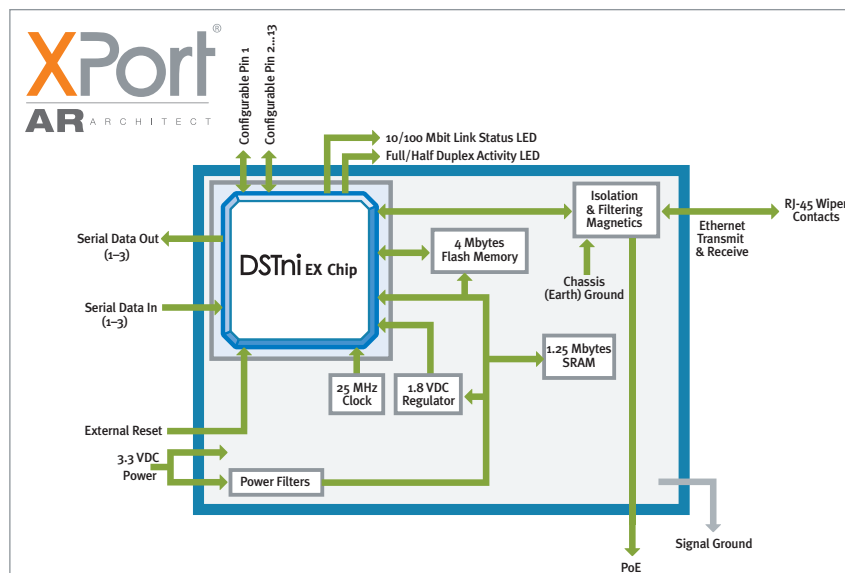

### Included Software

Evolution Network Operating System  
 Windows<sup>®</sup> XP/Server 2003/Vista/7 (x86 and x64)/Server 2008 (x86 and x64)-based DeviceInstaller<sup>™</sup> configuration software, Com Port Redirector<sup>™</sup> software and related utilities

### Part Number and Description

XP3002000-01R	XPort AR RoHS, Bulk, Extended Temperature -40° to 85°C
XP3002005-01R	XPort AR RoHS, Sample, Extended Temperature -40° to 85°C
XP3002000-01RJ	XPort AR RoHS, Bulk, Extended Temperature -40° to 85°C, Japan
XP300200K-01	XPort AR Evaluation Kit
EVSDK-01	Evolution Software Development Kit for XPort AR

**XPort AR Evaluation Kits are available, contact Lantronix for details.**

**Lantronix Corporate Headquarters**  
 167 Technology Drive  
 Irvine CA 92618  
 t: 800.422.7055  
 sales@lantronix.com

**European Headquarters**  
 t: +31 (0) 76 52 36 74 4  
 EMEA@lantronix.com

**Asia/Pacific Headquarters**  
 t: +852 3428 2338  
 asiapacific\_sales@lantronix.com

**Japan Headquarters**  
 t: +81.3.6277.8802  
 japan\_sales@lantronix.com