

Welcome to E-XFL.COM

Understanding [Embedded - Microcontroller, Microprocessor, FPGA Modules](#)

Embedded - Microcontroller, Microprocessor, and FPGA Modules are fundamental components in modern electronic systems, offering a wide range of functionalities and capabilities. Microcontrollers are compact integrated circuits designed to execute specific control tasks within an embedded system. They typically include a processor, memory, and input/output peripherals on a single chip. Microprocessors, on the other hand, are more powerful processing units used in complex computing tasks, often requiring external memory and peripherals. FPGAs (Field Programmable Gate Arrays) are highly flexible devices that can be configured by the user to perform specific logic functions, making them invaluable in applications requiring customization and adaptability.

Applications of [Embedded - Microcontroller,](#)

Details

Product Status	Obsolete
Module/Board Type	MPU Core
Core Processor	ARM920T, SC2440
Co-Processor	-
Speed	400MHz
Flash Size	32MB
RAM Size	32MB
Connector Type	Board-to-Board (BTB) Socket - 240
Size / Dimension	2.36" x 1.73" (60mm x 44mm)
Operating Temperature	-25°C ~ 75°C
Purchase URL	https://www.e-xfl.com/product-detail/digi-international/fs-372

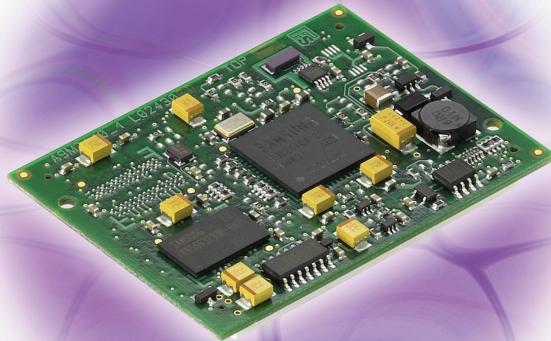

High-performance ARM9 core module with complete embedded platform support combines processor performance, low power requirements and rich peripheral support in an ultra-compact form factor.

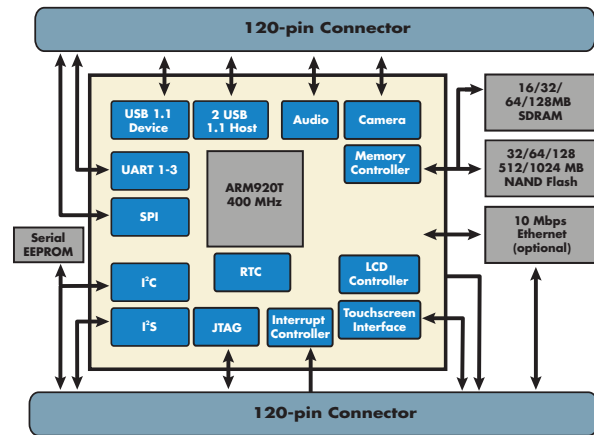

Features/Benefits

- High-performance core processor module in compact form factor
- Powerful 32-bit RISC processor with on-chip peripheral options
- 300/400 MHz Samsung S3C2440 microprocessor with ARM920T core
- Very low-power operation modes with Dynamic Voltage Scaling
- Up to 2 GB Flash and 512 MB SDRAM
- Optional 10 Mbit Ethernet MAC/PHY
- Strong multimedia capabilities with integrated LCD and touch screen controller and audio interfaces
- USB host/device support
- Memory/expansion card interfaces
- Complete embedded software platform offering with support and design services
- Microsoft Windows CE and Linux Development Kits available

Overview

The ConnectCore 9M module is the ideal solution for applications that require low-power operation: mobile, battery operated devices or those located in remote locations without readily available power. The module requires just 26 mA for normal operation at 3.3V, and can be put in idle mode where it draws just 2.6 mA.

The module combines low-power operation with a powerful ARM9 microprocessor at speeds up to 400 MHz with a wide array of peripherals. The LCD controller provides support for both TFT and STN LCDs, and an integrated touch screen controller, making it perfect for embedded applications that include a user interface. In addition, the module provides on-chip audio capabilities, sophisticated power management options, optional network connectivity and complete embedded software platform flexibility. An external 32-bit address/data bus interface provides additional flexibility and almost unlimited design freedom.

Whether you want to leverage the feature-complete selection of the high-level software components and applications in Microsoft® Windows® CE, or take advantage of the open Linux® environment with its community support and comprehensive software library, Digi offers a solution that meets your requirements while also dramatically shortening traditional time-to-market by minimizing the overall software and hardware designs risks.

Complete LxNETES™ (Linux for NETworked Embedded Systems) and Microsoft Windows CE Development Kits with module, development board, driver source code, documentation, Flash programming tools, cables and accessories are available for evaluation and development use. In addition, we offer professional support and product design services to assist you with your project-specific needs.

Features/Specifications

HARDWARE

- 32-bit Samsung S3C2440 ARM920T high-performance RISC processor @ 400 or 300 MHz
- Up to 2 GB NAND Flash and 512 MB SDRAM on-board
- 1024-bit 1-Wire® EEPROM
- Optional 10 Mbps Ethernet MAC/PHY (Cirrus Logic CS8900A)
- On-chip LCD controller for TFT/STN LCD panels
 - Up to VGA (640x480) resolution w/up to 24bpp color depth
- On-board USB 1.1 host/device
 - Full speed (12 Mbps) and low speed (1.5 Mbps) modes
- 3 RS-232 interfaces
- SD/SDIO Card interface
- One I²C bus interface w/fast mode (400 KHz) support
- I²S interface and AC'97 audio controller
- 32-bit external memory bus interface
- Up to 75 GPIO port options
- On-board JTAG interface

ENVIRONMENTAL

- Storage temperature: -50° C to 125° C (-58° F to 257° F)
- Operating temperature: -25° C to 75° C (-13° F to 167° F)
- Relative humidity: 5% to 90% (non-condensing)
- Altitude: 12,000 feet (3658 meters)

MODEL.....PART NUMBERS

Model	North America	International
ConnectCore 9P 2440 - 400 MHz, 32/32 (No Ethernet)	FS-3007	FS-3007
ConnectCore 9P 2440 - 400 MHz, 32/32 (10 MBit Ethernet)	FS-372	FS-372
LxNETES 3.2 Development Kit	FS-9071	FS-9071
Microsoft Windows CE 5.0 Development Kit	FS-9093	FS-9093

Please contact us for additional part number information, availability of processor speed grade population options, custom module populations, and our complete professional design/support services offering.

DEVELOPMENT KITS

- Linux
 - LxNETES 3.x CD
 - o GNU toolchain
 - o Linux kernel 2.6.x w/patches
 - o BSP source code
 - o Boot loader w/source files
 - o Sample files and documentation
 - ConnectCore 9M module
 - Development board
 - TFT LCD panel w/touch screen
 - Power supply and cords
 - JTAG booster and adapter
 - o Flash programming/verification
 - o I²C device access
 - o CPU signal tests
 - Optional technical support services
- Microsoft Windows CE 5.0
 - Microsoft Windows CE BSP CD
 - o BSP source code
 - o Boot loader w/source files
 - o Microsoft QFES
 - o Sample files and documentation
 - ConnectCore 9M module
 - Development board
 - TFT LCD panel w/touch screen
 - Power supply and cords
 - JTAG booster and adapter
 - o Flash programming/verification
 - o I²C device access
 - o CPU signal tests
 - Optional technical support services

POWER REQUIREMENTS

- 3.3VDC @ 26 mA / 180 mA (min/max)
- 3.3VDC @ 2.6 mA idle mode

ETHERNET INTERFACE

- Standard: IEEE 802.3
- Physical layer: 10 Base-T
- Data rate: 10 Mbps (auto-sensing)
- Mode: Full duplex

DIMENSIONS

- Length: 2.362 in (6.00 cm)
- Width: 1.732 in (4.4 cm)
- Height: 0.393 in (1.00 cm)

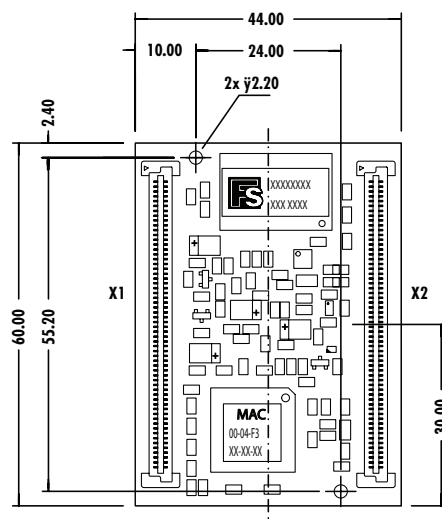

DIGI SERVICE AND SUPPORT - You can purchase with confidence knowing that Digi is here to support you with expert technical support and a strong five-year warranty. www.digi.com/support

WHEN
RELIABILITY
MATTERS™

Digi International

11001 Bren Road E.
Minnetonka, MN 55343
U.S.A.
PH: 877-912-3444
952-912-3444
FX: 952-912-4952
email: info@digi.com

Digi International France

31 rue des Poissonniers
92200 Neuilly sur Seine
PH: +33-1-55-61-98-98
FX: +33-1-55-61-98-99
www.digi.fr

Digi International KK

NES Building South 8F
22-14 Sakuragaoka-cho,
Shibuya-ku
Tokyo 150-0031, Japan
PH: +81-3-5428-0261
FX: +81-3-5428-0262
www.digi-intl.co.jp

Digi International (HK) Limited

Suite 1703-05, 17/F.,
K Wah Centre
191 Java Road
North Point, Hong Kong
PH: +852-2833-1008
FX: +852-2572-9989
www.digi.cn

Digi International, the leader in device networking for business, develops reliable products and technologies to connect and securely manage local or remote electronic devices over the network or via the web. With over 20 million ports shipped worldwide since 1985, Digi offers the highest levels of performance, flexibility and quality.

www.digi.com

© 2006-2008 Digi International Inc.

Digi, Digi International, the Digi logo, the When Reliability Matters logo, ConnectCore and LxNETES are trademarks or registered trademarks of Digi International, Inc in the United States and other countries worldwide. ARM is a trademark of ARM Limited. All other trademarks are the property of their respective owners.

91001393
B1/208

