



Welcome to E-XFL.COM

Understanding **Embedded - FPGAs (Field Programmable Gate Array)**

Embedded - FPGAs, or Field Programmable Gate Arrays, are advanced integrated circuits that offer unparalleled flexibility and performance for digital systems. Unlike traditional fixed-function logic devices, FPGAs can be programmed and reprogrammed to execute a wide array of logical operations, enabling customized functionality tailored to specific applications. This reprogrammability allows developers to iterate designs quickly and implement complex functions without the need for custom hardware.

Applications of Embedded - FPGAs

The versatility of Embedded - FPGAs makes them indispensable in numerous fields. In telecommunications.

Details

Product Status	Obsolete
Number of LABs/CLBs	8448
Number of Logic Elements/Cells	-
Total RAM Bits	2654208
Number of I/O	1104
Number of Gates	6000000
Voltage - Supply	1.425V ~ 1.575V
Mounting Type	Surface Mount
Operating Temperature	-40°C ~ 100°C (TJ)
Package / Case	1517-BBGA, FCBGA
Supplier Device Package	1517-FCBGA (40x40)
Purchase URL	https://www.e-xfl.com/product-detail/xilinx/xc2v6000-4ff1517i

Revision History

This section records the change history for this module of the data sheet.

Date	Version	Revision
11/07/00	1.0	Early access draft.
12/06/00	1.1	Initial release.
01/15/01	1.2	Added values to the tables in the Virtex-II Performance Characteristics and Virtex-II Switching Characteristics sections.
01/25/01	1.3	The data sheet was divided into four modules (per the current style standard).
04/02/01	1.5	Skipped v1.4 to sync up modules. Reverted to traditional double-column format.
07/30/01	1.6	Made minor changes to items listed under Summary of Virtex-II™ Features .
10/02/01	1.7	Minor edits.
07/16/02	1.8	Updated Virtex-II Device/Package Combinations shown in Table 6 .
09/26/02	1.9	Updated Table 2 and Table 6 to reflect supported Virtex-II Device/Package Combinations.
08/01/03	2.0	All Virtex-II devices and speed grades now Production. See Table 13 , Module 3.
03/29/04	2.0.1	Recompiled for backward compatibility with Acrobat 4 and above. No content changes.
06/24/04	3.3	Added references to available Pb-free wire-bond packages. (Revision number advanced to level of complete data sheet.)
03/01/05	3.4	<i>No changes in Module 1 for this revision.</i>
11/05/07	3.5	Updated copyright notice and legal disclaimer.

Notice of Disclaimer

THE XILINX HARDWARE FPGA AND CPLD DEVICES REFERRED TO HEREIN (“PRODUCTS”) ARE SUBJECT TO THE TERMS AND CONDITIONS OF THE XILINX LIMITED WARRANTY WHICH CAN BE VIEWED AT <http://www.xilinx.com/warranty.htm>. THIS LIMITED WARRANTY DOES NOT EXTEND TO ANY USE OF PRODUCTS IN AN APPLICATION OR ENVIRONMENT THAT IS NOT WITHIN THE SPECIFICATIONS STATED IN THE XILINX DATA SHEET. ALL SPECIFICATIONS ARE SUBJECT TO CHANGE WITHOUT NOTICE. PRODUCTS ARE NOT DESIGNED OR INTENDED TO BE FAIL-SAFE OR FOR USE IN ANY APPLICATION REQUIRING FAIL-SAFE PERFORMANCE, SUCH AS LIFE-SUPPORT OR SAFETY DEVICES OR SYSTEMS, OR ANY OTHER APPLICATION THAT INVOKES THE POTENTIAL RISKS OF DEATH, PERSONAL INJURY, OR PROPERTY OR ENVIRONMENTAL DAMAGE (“CRITICAL APPLICATIONS”). USE OF PRODUCTS IN CRITICAL APPLICATIONS IS AT THE SOLE RISK OF CUSTOMER, SUBJECT TO APPLICABLE LAWS AND REGULATIONS.

Virtex-II Data Sheet

The Virtex-II Data Sheet contains the following modules:

- [Virtex-II Platform FPGAs: Introduction and Overview \(Module 1\)](#)
- [Virtex-II Platform FPGAs: Functional Description \(Module 2\)](#)
- [Virtex-II Platform FPGAs: DC and Switching Characteristics \(Module 3\)](#)
- [Virtex-II Platform FPGAs: Pinout Information \(Module 4\)](#)

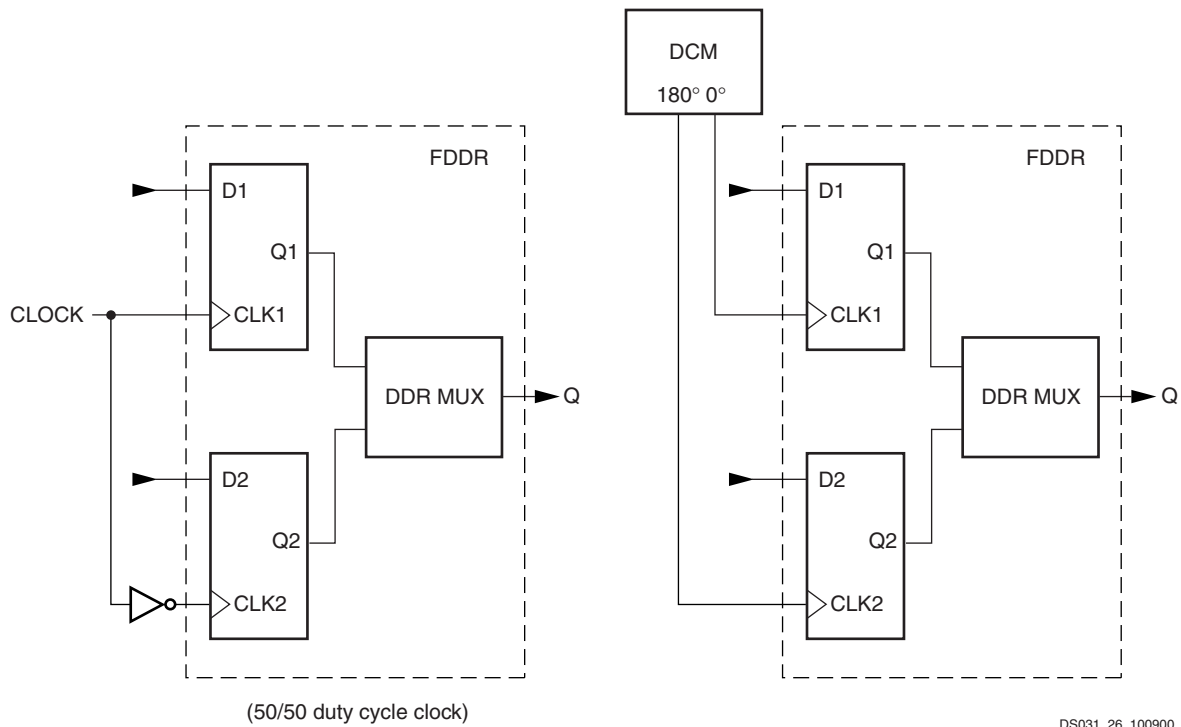

Figure 3: Double Data Rate Registers

The DDR mechanism shown in Figure 3 can be used to mirror a copy of the clock on the output. This is useful for propagating a clock along the data that has an identical delay. It is also useful for multiple clock generation, where there is a unique clock driver for every clock load. Virtex-II devices can produce many copies of a clock with very little skew.

Each group of two registers has a clock enable signal (ICE for the input registers, OCE for the output registers, and TCE for the 3-state registers). The clock enable signals are active High by default. If left unconnected, the clock enable for that storage element defaults to the active state.

Each IOB block has common synchronous or asynchronous set and reset (SR and REV signals).

SR forces the storage element into the state specified by the SRHIGH or SRLow attribute. SRHIGH forces a logic “1”. SRLow forces a logic “0”. When SR is used, a second input (REV) forces the storage element into the opposite state. The reset condition predominates over the set condition. The initial state after configuration or global initialization state is defined by a separate INIT0 and INIT1 attribute. By default, the SRLow attribute forces INIT0, and the SRHIGH attribute forces INIT1.

For each storage element, the SRHIGH, SRLow, INIT0, and INIT1 attributes are independent. Synchronous or asynchronous set / reset is consistent in an IOB block.

All the control signals have independent polarity. Any inverter placed on a control input is automatically absorbed.

Each register or latch (independent of all other registers or latches) (see Figure 4) can be configured as follows:

- No set or reset
- Synchronous set
- Synchronous reset
- Synchronous set and reset
- Asynchronous set (preset)
- Asynchronous reset (clear)
- Asynchronous set and reset (preset and clear)

The synchronous reset overrides a set, and an asynchronous clear overrides a preset.

Table 5: Summary of Voltage Supply Requirements for All Input and Output Standards

I/O Standard	V _{CCO}		V _{REF}	Termination Type	
	Output	Input	Input	Output	Input
LVDS_33	3.3	N/R	N/R ⁽¹⁾	N/R	N/R
LVDS_33			N/R	N/R	N/R
LVPECL_33			N/R	N/R	N/R
SSTL3_I			1.5	N/R	N/R
SSTL3_II			1.5	N/R	N/R
AGP			1.32	N/R	N/R
LVTTTL			N/R	N/R	N/R
LVCOS33		3.3	N/R	N/R	N/R
LVDCI_33			N/R	Series	N/R
LVDCI_DV2_33			N/R	Series	N/R
PCI33_3			N/R	N/R	N/R
PCI66_3			N/R	N/R	N/R
PCIX			N/R	N/R	N/R
SSTL3_I_DCI			1.5	N/R	Split
SSTL3_II_DCI	1.5	Split	Split		
LVDS_25	2.5	N/R	N/R	N/R	N/R
LVDS_25			N/R	N/R	N/R
LDT_25			N/R	N/R	N/R
ULVDS_25			N/R	N/R	N/R
BLVDS_25			N/R	N/R	N/R
SSTL2_I			1.25	N/R	N/R
SSTL2_II			1.25	N/R	N/R
LVCOS25		2.5	N/R	N/R	N/R
LVDCI_25			N/R	Series	N/R
LVDCI_DV2_25			N/R	Series	N/R
LVDS_25_DCI			N/R	N/R	Split
LVDS_25_DC I			N/R	N/R	Split
SSTL2_I_DCI			1.25	N/R	Split
SSTL2_II_DCI			1.25	Split	Split

Table 5: Summary of Voltage Supply Requirements for All Input and Output Standards (Continued)

I/O Standard	V _{CCO}		V _{REF}	Termination Type			
	Output	Input	Input	Output	Input		
HSTL_III_18	1.8	N/R	1.1	N/R	N/R		
HSTL_IV_18			1.1	N/R	N/R		
HSTL_I_18			0.9	N/R	N/R		
HSTL_II_18			0.9	N/R	N/R		
SSTL18_I			0.9	N/R	N/R		
SSTL18_II			0.9	N/R	N/R		
LVCOS18			1.8	N/R	N/R	N/R	
LVDCI_18		N/R		Series	N/R		
LVDCI_DV2_18		N/R		Series	N/R		
HSTL_III_DCI_18		1.1		N/R	Single		
HSTL_IV_DCI_18		1.1		Single	Single		
HSTL_I_DCI_18		0.9		N/R	Split		
HSTL_II_DCI_18		0.9		Split	Split		
SSTL18_I_DCI		0.9	N/R	Split			
SSTL18_II_DCI	0.9	Split	Split				
HSTL_III	1.5	N/R	0.9	N/R	N/R		
HSTL_IV			0.9	N/R	N/R		
HSTL_I			0.75	N/R	N/R		
HSTL_II			0.75	N/R	N/R		
LVCOS15		1.5	N/R	N/R	N/R	N/R	
LVDCI_15				N/R	Series	N/R	
LVDCI_DV2_15				N/R	Series	N/R	
GTLP_DCI				1	Single	Single	
HSTL_III_DCI			0.9	N/R	Single		
HSTL_IV_DCI			0.9	Single	Single		
HSTL_I_DCI			0.75	N/R	Split		
HSTL_II_DCI			0.75	Split	Split		
GTL_DCI			1.2	1.2	0.8	Single	Single
GTLP			N/R	N/R	1	N/R	N/R
GTL	0.8	N/R			N/R		

Notes:

1. N/R = no requirement.

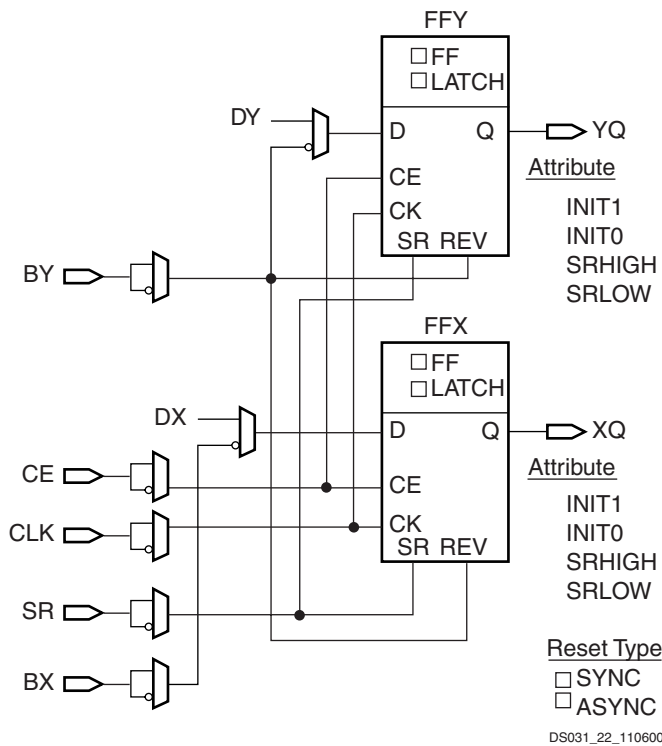

Figure 17: Register / Latch Configuration in a Slice

The set and reset functionality of a register or a latch can be configured as follows:

- No set or reset
- Synchronous set
- Synchronous reset
- Synchronous set and reset
- Asynchronous set (preset)
- Asynchronous reset (clear)
- Asynchronous set and reset (preset and clear)

The synchronous reset has precedence over a set, and an asynchronous clear has precedence over a preset.

Distributed SelectRAM Memory

Each function generator (LUT) can implement a 16 x 1-bit synchronous RAM resource called a distributed SelectRAM element. The SelectRAM elements are configurable within a CLB to implement the following:

- Single-Port 16 x 8 bit RAM
- Single-Port 32 x 4 bit RAM
- Single-Port 64 x 2 bit RAM
- Single-Port 128 x 1 bit RAM
- Dual-Port 16 x 4 bit RAM
- Dual-Port 32 x 2 bit RAM
- Dual-Port 64 x 1 bit RAM

Distributed SelectRAM memory modules are synchronous (write) resources. The combinatorial read access time is extremely fast, while the synchronous write simplifies high-speed designs. A synchronous read can be implemented with a storage element in the same slice. The distributed SelectRAM memory and the storage element share the same clock input. A Write Enable (WE) input is active High, and is driven by the SR input.

Table 9 shows the number of LUTs (2 per slice) occupied by each distributed SelectRAM configuration.

Table 9: Distributed SelectRAM Configurations

RAM	Number of LUTs
16 x 1S	1
16 x 1D	2
32 x 1S	2
32 x 1D	4
64 x 1S	4
64 x 1D	8
128 x 1S	8

Notes:

1. S = single-port configuration; D = dual-port configuration

For single-port configurations, distributed SelectRAM memory has one address port for synchronous writes and asynchronous reads.

For dual-port configurations, distributed SelectRAM memory has one port for synchronous writes and asynchronous reads and another port for asynchronous reads. The function generator (LUT) has separated read address inputs (A1, A2, A3, A4) and write address inputs (WG1/WF1, WG2/WF2, WG3/WF3, WG4/WF4).

In single-port mode, read and write addresses share the same address bus. In dual-port mode, one function generator (R/W port) is connected with shared read and write addresses. The second function generator has the A inputs (read) connected to the second read-only port address and the W inputs (write) shared with the first read/write port address.

Notice of Disclaimer

THE XILINX HARDWARE FPGA AND CPLD DEVICES REFERRED TO HEREIN (“PRODUCTS”) ARE SUBJECT TO THE TERMS AND CONDITIONS OF THE XILINX LIMITED WARRANTY WHICH CAN BE VIEWED AT <http://www.xilinx.com/warranty.htm>. THIS LIMITED WARRANTY DOES NOT EXTEND TO ANY USE OF PRODUCTS IN AN APPLICATION OR ENVIRONMENT THAT IS NOT WITHIN THE SPECIFICATIONS STATED IN THE XILINX DATA SHEET. ALL SPECIFICATIONS ARE SUBJECT TO CHANGE WITHOUT NOTICE. PRODUCTS ARE NOT DESIGNED OR INTENDED TO BE FAIL-SAFE OR FOR USE IN ANY APPLICATION REQUIRING FAIL-SAFE PERFORMANCE, SUCH AS LIFE-SUPPORT OR SAFETY DEVICES OR SYSTEMS, OR ANY OTHER APPLICATION THAT INVOKES THE POTENTIAL RISKS OF DEATH, PERSONAL INJURY, OR PROPERTY OR ENVIRONMENTAL DAMAGE (“CRITICAL APPLICATIONS”). USE OF PRODUCTS IN CRITICAL APPLICATIONS IS AT THE SOLE RISK OF CUSTOMER, SUBJECT TO APPLICABLE LAWS AND REGULATIONS.

Virtex-II Data Sheet

The Virtex-II Data Sheet contains the following modules:

- [Virtex-II Platform FPGAs: Introduction and Overview \(Module 1\)](#)
- [Virtex-II Platform FPGAs: Functional Description \(Module 2\)](#)
- [Virtex-II Platform FPGAs: DC and Switching Characteristics \(Module 3\)](#)
- [Virtex-II Platform FPGAs: Pinout Information \(Module 4\)](#)

Date	Version	Revision
07/30/01	1.6	<ul style="list-style-type: none"> Updated values in the Virtex-II Performance Characteristics and Virtex-II Switching Characteristics tables. Added values to the Virtex-II Pin-to-Pin Output Parameter Guidelines and Virtex-II Pin-to-Pin Input Parameter Guidelines tables. Added Frequency Synthesis table.
10/02/01	1.7	<ul style="list-style-type: none"> Updated values in the Virtex-II Performance Characteristics and Virtex-II Switching Characteristics tables. Updated the speed grade designations used in data sheets, and added Table 13, which shows the current speed grade designation for each device.
10/05/01	1.8	<ul style="list-style-type: none"> Corrected the speed grade designation for the XC2V1000 device in Table 13.
10/12/01	1.9	<ul style="list-style-type: none"> Updated values in the Virtex-II Performance Characteristics and Virtex-II Switching Characteristics tables.
11/28/01	2.0	<ul style="list-style-type: none"> Updated values in Table 3, Table 4, Table 5, Virtex-II Performance Characteristics, and Virtex-II Switching Characteristics tables.
01/03/02	2.1	<ul style="list-style-type: none"> Updated values in Virtex-II Performance Characteristics and Virtex-II Switching Characteristics tables, based on values extracted from speedsfile version 1.96. Changed the speed grade designation for the XC2V6000 device in Table 13.
07/16/02	2.2	<ul style="list-style-type: none"> Updated values in Table 4, "Quiescent Supply Current." Updated values in Virtex-II Performance Characteristics and Virtex-II Switching Characteristics tables, based on values extracted from speedsfile version 1.111. Added Enhanced Multiplier Switching Characteristics section. Added footnote to Table 37, "Global Clock Setup and Hold for LVTTTL Standard, Without DCM." Added Source-Synchronous Switching Characteristics section.
09/26/02	2.3	<ul style="list-style-type: none"> Removed mention of MIL-M-38510/605 specification. Added footnotes to Table 2 and Table 6.
12/06/02	2.4	<ul style="list-style-type: none"> Revised SSTL2 values in Table 6 to match the latest JEDEC specification. Added footnote regarding V_{IN} PCI compliance to Table 1. Added footnote regarding CLKOUT_DUTY_CYCLE_DLL to Table 41.
05/07/03	2.5	<ul style="list-style-type: none"> Updated values in Virtex-II Performance Characteristics and Virtex-II Switching Characteristics tables, based on values extracted from speedsfile version 1.114. Table 4, Quiescent Supply Current, and Table 5, Minimum Power On Current Required for Virtex-II Devices: Added parameters for XC2V8000 device. Table 16, IOB Output Switching Characteristics: Changed parameter designator T_{IOTON} to T_{IOTP}. Table 26, Enhanced Multiplier Switching Characteristics: Corrected all parameter designators from $T_{MULT_P[nn]}$ to $T_{MULT1_P[nn]}$ in order to correspond with designators used in speedsfile. Table 27, Enhanced Pipelined Multiplier Switching Characteristics: Corrected all parameter designators from $T_{MULTCK_P[nn]}$ to $T_{MULTCK1_P[nn]}$ in order to correspond with designators used in speedsfile. Removed old Table 19, Standard Capacitive Loads. Added Figure 1, page 17, showing test configuration for measuring I/O standard adjustments.
06/19/03	2.5.1	<ul style="list-style-type: none"> Removed footnotes in Table 34 and Table 36 that stated DCM jitter was included in the measurements.

FG256/FGG256 Fine-Pitch BGA Package

As shown in Table 6, XC2V40, XC2V80, XC2V250, XC2V500, and XC2V1000 Virtex-II devices are available in the FG256/FGG256 fine-pitch BGA package. The pins in the XC2V250, XC2V500, and XC2V1000 devices are same. The No Connect columns show pin differences for the XC2V40 and XC2V80 devices. Following this table are the **FG256/FGG256 Fine-Pitch BGA Package Specifications (1.00mm pitch)**.

Table 6: FG256/FGG256 BGA — XC2V40, XC2V80, XC2V250, XC2V500, and XC2V1000

Bank	Pin Description	Pin Number	No Connect in XC2V40	No Connect in XC2V80
0	IO_L01N_0	C4		
0	IO_L01P_0	B4		
0	IO_L02N_0	D5		
0	IO_L02P_0	C5		
0	IO_L03N_0/VRP_0	B5		
0	IO_L03P_0/VRN_0	A5		
0	IO_L04N_0/VREF_0	D6	NC	NC
0	IO_L04P_0	C6	NC	NC
0	IO_L05N_0	B6	NC	NC
0	IO_L05P_0	A6	NC	NC
0	IO_L92N_0	E6	NC	NC
0	IO_L92P_0	E7	NC	NC
0	IO_L93N_0	D7	NC	NC
0	IO_L93P_0	C7	NC	NC
0	IO_L94N_0/VREF_0	B7		
0	IO_L94P_0	A7		
0	IO_L95N_0/GCLK7P	D8		
0	IO_L95P_0/GCLK6S	C8		
0	IO_L96N_0/GCLK5P	B8		
0	IO_L96P_0/GCLK4S	A8		
1	IO_L96N_1/GCLK3P	A9		
1	IO_L96P_1/GCLK2S	B9		
1	IO_L95N_1/GCLK1P	C9		
1	IO_L95P_1/GCLK0S	D9		
1	IO_L94N_1	A10		
1	IO_L94P_1/VREF_1	B10		
1	IO_L93N_1	C10	NC	NC
1	IO_L93P_1	D10	NC	NC
1	IO_L92N_1	E10	NC	NC

Table 6: FG256/FGG256 BGA — XC2V40, XC2V80, XC2V250, XC2V500, and XC2V1000

Bank	Pin Description	Pin Number	No Connect in XC2V40	No Connect in XC2V80
3	IO_L96N_3	J16		
3	IO_L96P_3	J15		
3	IO_L94N_3	J14		
3	IO_L94P_3	J13		
3	IO_L93N_3/VREF_3	K16	NC	
3	IO_L93P_3	K15	NC	
3	IO_L91N_3	K14	NC	
3	IO_L91P_3	K13	NC	
3	IO_L45N_3/VREF_3	K12	NC	NC
3	IO_L45P_3	L12	NC	NC
3	IO_L43N_3	L16	NC	NC
3	IO_L43P_3	L15	NC	NC
3	IO_L06N_3	L14	NC	
3	IO_L06P_3	L13	NC	
3	IO_L04N_3	M16	NC	
3	IO_L04P_3	M15	NC	
3	IO_L03N_3/VREF_3	M14		
3	IO_L03P_3	M13		
3	IO_L02N_3/VRP_3	N15		
3	IO_L02P_3/VRN_3	N14		
3	IO_L01N_3	N16		
3	IO_L01P_3	P16		
4	IO_L01N_4/BUSY/DOUT ⁽¹⁾	T14		
4	IO_L01P_4/INIT_B	T13		
4	IO_L02N_4/D0/DIN ⁽¹⁾	P13		
4	IO_L02P_4/D1	R13		
4	IO_L03N_4/D2/ALT_VRP_4	N12		
4	IO_L03P_4/D3/ALT_VRN_4	P12		
4	IO_L04N_4/VREF_4	R12	NC	NC
4	IO_L04P_4	T12	NC	NC
4	IO_L05N_4/VRP_4	N11	NC	NC
4	IO_L05P_4/VRN_4	P11	NC	NC

FG676/FGG676 Fine-Pitch BGA Package

As shown in Table 8, XC2V1500, XC2V2000, and XC2V3000 Virtex-II devices are available in the FG676/FGG676 fine-pitch BGA package. Pins in the XC2V1500, XC2V2000, and XC2V3000 devices are the same, except for the pin differences in the XC2V1500 and XC2V2000 devices shown in the No Connect columns. Following this table are the **FG676/FGG676 Fine-Pitch BGA Package Specifications (1.00mm pitch)**.

Table 8: FG676/FGG676 BGA — XC2V1500, XC2V2000, and XC2V3000

Bank	Pin Description	Pin Number	No Connect in XC2V1500	No Connect in XC2V2000
0	IO_L01N_0	D6		
0	IO_L01P_0	C6		
0	IO_L02N_0	B1		
0	IO_L02P_0	A2		
0	IO_L03N_0/VRP_0	D7		
0	IO_L03P_0/VRN_0	C7		
0	IO_L04N_0/VREF_0	B3		
0	IO_L04P_0	A3		
0	IO_L05N_0	G6		
0	IO_L05P_0	G7		
0	IO_L06N_0	E6		
0	IO_L06P_0	E7		
0	IO_L19N_0	B4		
0	IO_L19P_0	A4		
0	IO_L21N_0	B5		
0	IO_L21P_0/VREF_0	A5		
0	IO_L22N_0	B6		
0	IO_L22P_0	A6		
0	IO_L24N_0	A7		
0	IO_L24P_0	A8		
0	IO_L25N_0	E8	NC	NC
0	IO_L25P_0	D8	NC	NC
0	IO_L27N_0	G8	NC	NC
0	IO_L27P_0/VREF_0	F8	NC	NC
0	IO_L49N_0	C8		
0	IO_L49P_0	B8		
0	IO_L51N_0	D9		
0	IO_L51P_0/VREF_0	E9		
0	IO_L52N_0	F9		
0	IO_L52P_0	G9		
0	IO_L54N_0	B9		
0	IO_L54P_0	A9		
0	IO_L67N_0	C9		

Table 9: BG575/BGG575 BGA — XC2V1000, XC2V1500, and XC2V2000

Bank	Pin Description	Pin Number	No Connect in XC2V1000	No Connect in XC2V1500
0	IO_L69P_0/VREF_0	B9	NC	
0	IO_L70N_0	F10	NC	
0	IO_L70P_0	E10	NC	
0	IO_L72N_0	A10	NC	
0	IO_L72P_0	A11	NC	
0	IO_L73N_0	C10	NC	NC
0	IO_L73P_0	B10	NC	NC
0	IO_L91N_0/VREF_0	D11		
0	IO_L91P_0	C11		
0	IO_L92N_0	G11		
0	IO_L92P_0	E11		
0	IO_L93N_0	C12		
0	IO_L93P_0	B12		
0	IO_L94N_0/VREF_0	E12		
0	IO_L94P_0	D12		
0	IO_L95N_0/GCLK7P	G12		
0	IO_L95P_0/GCLK6S	F12		
0	IO_L96N_0/GCLK5P	H11		
0	IO_L96P_0/GCLK4S	H12		
1	IO_L96N_1/GCLK3P	A13		
1	IO_L96P_1/GCLK2S	A14		
1	IO_L95N_1/GCLK1P	B13		
1	IO_L95P_1/GCLK0S	C13		
1	IO_L94N_1	D13		
1	IO_L94P_1/VREF_1	E13		
1	IO_L93N_1	F13		
1	IO_L93P_1	G13		
1	IO_L92N_1	H13		
1	IO_L92P_1	H14		
1	IO_L91N_1	C14		
1	IO_L91P_1/VREF_1	D14		
1	IO_L73N_1	E14	NC	NC
1	IO_L73P_1	G14	NC	NC
1	IO_L72N_1	A15	NC	
1	IO_L72P_1	A16	NC	

Table 10: BG728 BGA — XC2V3000

Bank	Pin Description	Pin Number
2	IO_L70P_2	N19
2	IO_L72N_2	M22
2	IO_L72P_2	M23
2	IO_L73N_2	M24
2	IO_L73P_2	N24
2	IO_L75N_2	M26
2	IO_L75P_2/VREF_2	M27
2	IO_L76N_2	N20
2	IO_L76P_2	N21
2	IO_L78N_2	N22
2	IO_L78P_2	N23
2	IO_L91N_2	N25
2	IO_L91P_2	P25
2	IO_L93N_2	N26
2	IO_L93P_2/VREF_2	N27
2	IO_L94N_2	P20
2	IO_L94P_2	P21
2	IO_L96N_2	P22
2	IO_L96P_2	P23
3	IO_L96N_3	R27
3	IO_L96P_3	R26
3	IO_L94N_3	R25
3	IO_L94P_3	R24
3	IO_L93N_3/VREF_3	R23
3	IO_L93P_3	T23
3	IO_L91N_3	R22
3	IO_L91P_3	R21
3	IO_L78N_3	R20
3	IO_L78P_3	R19
3	IO_L76N_3	T27
3	IO_L76P_3	T26
3	IO_L75N_3/VREF_3	T24
3	IO_L75P_3	U24
3	IO_L73N_3	T22
3	IO_L73P_3	U22

Table 10: BG728 BGA — XC2V3000

Bank	Pin Description	Pin Number
3	IO_L19N_3	AB26
3	IO_L19P_3	AB25
3	IO_L06N_3	AB24
3	IO_L06P_3	AB23
3	IO_L04N_3	AC27
3	IO_L04P_3	AC26
3	IO_L03N_3/VREF_3	AC25
3	IO_L03P_3	AC24
3	IO_L02N_3/VRP_3	AD27
3	IO_L02P_3/VRN_3	AE27
3	IO_L01N_3	AD26
3	IO_L01P_3	AD25
4	IO_L01N_4/BUSY/DOOUT ⁽¹⁾	AF25
4	IO_L01P_4/INIT_B	AG25
4	IO_L02N_4/D0/DIN ⁽¹⁾	AF24
4	IO_L02P_4/D1	AG24
4	IO_L03N_4/D2/ALT_VRP_4	AD23
4	IO_L03P_4/D3/ALT_VRN_4	AE23
4	IO_L04N_4/VREF_4	AF23
4	IO_L04P_4	AG23
4	IO_L05N_4/VRP_4	AD22
4	IO_L05P_4/VRN_4	AE22
4	IO_L06N_4	AF22
4	IO_L06P_4	AG22
4	IO_L19N_4	AC21
4	IO_L19P_4	AB21
4	IO_L21N_4	AE21
4	IO_L21P_4/VREF_4	AE20
4	IO_L22N_4	AF21
4	IO_L22P_4	AG21
4	IO_L24N_4	AB20
4	IO_L24P_4	AA20
4	IO_L25N_4	AC20
4	IO_L25P_4	AD20
4	IO_L27N_4	AG20

Table 11: FF896 BGA — XC2V1000, XC2V1500, and XC2V2000

Bank	Pin Description	Pin Number	No Connect in the XC2V1000	No Connect in the XC2V1500
1	IO_L68P_1	G12	NC	
1	IO_L67N_1	A9	NC	
1	IO_L67P_1	A10	NC	
1	IO_L54N_1	E10		
1	IO_L54P_1	E11		
1	IO_L53N_1	H12		
1	IO_L53P_1	H11		
1	IO_L52N_1	D9		
1	IO_L52P_1	D10		
1	IO_L51N_1/VREF_1	C9		
1	IO_L51P_1	C8		
1	IO_L50N_1	F11		
1	IO_L50P_1	F10		
1	IO_L49N_1	B8		
1	IO_L49P_1	B9		
1	IO_L24N_1	E8		
1	IO_L24P_1	E9		
1	IO_L23N_1	G11		
1	IO_L23P_1	H10		
1	IO_L22N_1	B7		
1	IO_L22P_1	A7		
1	IO_L21N_1/VREF_1	D8		
1	IO_L21P_1	E7		
1	IO_L20N_1	G10		
1	IO_L20P_1	G9		
1	IO_L19N_1	A5		
1	IO_L19P_1	A6		
1	IO_L06N_1	C6		
1	IO_L06P_1	C7		
1	IO_L05N_1	F9		
1	IO_L05P_1	G8		
1	IO_L04N_1	B6		
1	IO_L04P_1/VREF_1	C5		
1	IO_L03N_1/VRP_1	D7		
1	IO_L03P_1/VRN_1	D6		
1	IO_L02N_1	F8		
1	IO_L02P_1	F7		

Table 12: FF1152 BGA — XC2V3000, XC2V4000, XC2V6000, and XC2V8000

Bank	Pin Description	Pin Number	No Connect in the XC2V3000
2	IO_L51N_2	L6	
2	IO_L51P_2/VREF_2	M6	
2	IO_L52N_2	M3	
2	IO_L52P_2	L3	
2	IO_L53N_2	L4	
2	IO_L53P_2	K4	
2	IO_L54N_2	N4	
2	IO_L54P_2	M4	
2	IO_L67N_2	M2	
2	IO_L67P_2	L2	
2	IO_L68N_2	N8	
2	IO_L68P_2	P8	
2	IO_L69N_2	N6	
2	IO_L69P_2/VREF_2	P6	
2	IO_L70N_2	P5	
2	IO_L70P_2	N5	
2	IO_L71N_2	P10	
2	IO_L71P_2	R10	
2	IO_L72N_2	P3	
2	IO_L72P_2	N3	
2	IO_L73N_2	M1	
2	IO_L73P_2	L1	
2	IO_L74N_2	P9	
2	IO_L74P_2	R9	
2	IO_L75N_2	P2	
2	IO_L75P_2/VREF_2	N2	
2	IO_L76N_2	R4	
2	IO_L76P_2	P4	
2	IO_L77N_2	R8	
2	IO_L77P_2	T8	
2	IO_L78N_2	T3	
2	IO_L78P_2	R3	
2	IO_L79N_2	P1	NC
2	IO_L79P_2	N1	NC
2	IO_L80N_2	T11	NC
2	IO_L80P_2	U11	NC

Table 12: FF1152 BGA — XC2V3000, XC2V4000, XC2V6000, and XC2V8000

Bank	Pin Description	Pin Number	No Connect in the XC2V3000
5	VCCO_5	AP19	
5	VCCO_5	AL28	
5	VCCO_5	AK20	
5	VCCO_5	AD23	
5	VCCO_5	AD22	
5	VCCO_5	AD21	
5	VCCO_5	AD20	
5	VCCO_5	AC22	
5	VCCO_5	AC21	
5	VCCO_5	AC20	
5	VCCO_5	AC19	
5	VCCO_5	AC18	
6	VCCO_6	AH31	
6	VCCO_6	AE34	
6	VCCO_6	AC24	
6	VCCO_6	AB24	
6	VCCO_6	AB23	
6	VCCO_6	AA24	
6	VCCO_6	AA23	
6	VCCO_6	Y30	
6	VCCO_6	Y24	
6	VCCO_6	Y23	
6	VCCO_6	W34	
6	VCCO_6	W23	
6	VCCO_6	V23	
7	VCCO_7	U23	
7	VCCO_7	T34	
7	VCCO_7	T23	
7	VCCO_7	R30	
7	VCCO_7	R24	
7	VCCO_7	R23	
7	VCCO_7	P24	
7	VCCO_7	P23	
7	VCCO_7	N24	
7	VCCO_7	N23	
7	VCCO_7	M24	

Table 13: FF1517 BGA — XC2V4000, XC2V6000, and XC2V8000

Bank	Pin Description	Pin Number	No Connect in the XC2V4000	No Connect in the XC2V6000
2	IO_L09P_2/VREF_2	H7	NC	
2	IO_L10N_2	G3	NC	
2	IO_L10P_2	F3	NC	
2	IO_L11N_2	J8	NC	
2	IO_L11P_2	K8	NC	
2	IO_L12N_2	H5	NC	
2	IO_L12P_2	G5	NC	
2	IO_L19N_2	G1		
2	IO_L19P_2	F1		
2	IO_L20N_2	K9		
2	IO_L20P_2	L10		
2	IO_L21N_2	K7		
2	IO_L21P_2/VREF_2	J7		
2	IO_L22N_2	H2		
2	IO_L22P_2	G2		
2	IO_L23N_2	L9		
2	IO_L23P_2	M9		
2	IO_L24N_2	H4		
2	IO_L24P_2	G4		
2	IO_L25N_2	J3		
2	IO_L25P_2	H3		
2	IO_L26N_2	M10		
2	IO_L26P_2	N10		
2	IO_L27N_2	K6		
2	IO_L27P_2/VREF_2	J6		
2	IO_L28N_2	K5		
2	IO_L28P_2	J5		
2	IO_L29N_2	N11		
2	IO_L29P_2	P11		
2	IO_L30N_2	M7		
2	IO_L30P_2	L7		
2	IO_L31N_2	J1	NC	
2	IO_L31P_2	H1	NC	
2	IO_L32N_2	L8	NC	
2	IO_L32P_2	M8	NC	
2	IO_L33N_2	K4	NC	

Table 13: FF1517 BGA — XC2V4000, XC2V6000, and XC2V8000

Bank	Pin Description	Pin Number	No Connect in the XC2V4000	No Connect in the XC2V6000
5	IO_L25N_5	AV33		
5	IO_L25P_5	AV32		
5	IO_L24N_5	AR31		
5	IO_L24P_5	AR30		
5	IO_L23N_5	AL27		
5	IO_L23P_5	AL28		
5	IO_L22N_5	AW34		
5	IO_L22P_5	AW33		
5	IO_L21N_5/VREF_5	AN30		
5	IO_L21P_5	AP30		
5	IO_L20N_5	AM28		
5	IO_L20P_5	AM29		
5	IO_L19N_5	AU33		
5	IO_L19P_5	AU32		
5	IO_L12N_5	AT33	NC	
5	IO_L12P_5	AT32	NC	
5	IO_L11N_5	AK27	NC	
5	IO_L11P_5	AK28	NC	
5	IO_L10N_5	AV35	NC	
5	IO_L10P_5	AV34	NC	
5	IO_L09N_5/VREF_5	AP32	NC	
5	IO_L09P_5	AP31	NC	
5	IO_L08N_5	AL29	NC	
5	IO_L08P_5	AK29	NC	
5	IO_L07N_5	AW36	NC	
5	IO_L07P_5	AW35	NC	
5	IO_L06N_5	AR33		
5	IO_L06P_5	AR32		
5	IO_L05N_5/VRP_5	AM30		
5	IO_L05P_5/VRN_5	AL30		
5	IO_L04N_5	AU35		
5	IO_L04P_5/VREF_5	AU34		
5	IO_L03N_5/D4/ALT_VRP_5	AR34		
5	IO_L03P_5/D5/ALT_VRN_5	AT34		
5	IO_L02N_5/D6	AN31		
5	IO_L02P_5/D7	AM31		

Table 13: FF1517 BGA — XC2V4000, XC2V6000, and XC2V8000

Bank	Pin Description	Pin Number	No Connect in the XC2V4000	No Connect in the XC2V6000
NA	VCCINT	R19		
NA	VCCINT	R18		
NA	VCCINT	R17		
NA	VCCINT	R16		
NA	VCCINT	R15		
NA	VCCINT	P26		
NA	VCCINT	P20		
NA	VCCINT	P14		
NA	VCCINT	N27		
NA	VCCINT	N20		
NA	VCCINT	N13		
NA	GND	AW38		
NA	GND	AW37		
NA	GND	AW20		
NA	GND	AW3		
NA	GND	AW2		
NA	GND	AV39		
NA	GND	AV38		
NA	GND	AV37		
NA	GND	AV29		
NA	GND	AV11		
NA	GND	AV3		
NA	GND	AV2		
NA	GND	AV1		
NA	GND	AU39		
NA	GND	AU38		
NA	GND	AU37		
NA	GND	AU3		
NA	GND	AU2		
NA	GND	AU1		
NA	GND	AT36		
NA	GND	AT23		
NA	GND	AT20		
NA	GND	AT17		
NA	GND	AT4		
NA	GND	AR35		

Table 13: FF1517 BGA — XC2V4000, XC2V6000, and XC2V8000

Bank	Pin Description	Pin Number	No Connect in the XC2V4000	No Connect in the XC2V6000
NA	GND	U4		
NA	GND	T23		
NA	GND	T22		
NA	GND	T21		
NA	GND	T20		
NA	GND	T19		
NA	GND	T18		
NA	GND	T17		
NA	GND	P35		
NA	GND	P5		
NA	GND	L38		
NA	GND	L29		
NA	GND	L11		
NA	GND	L2		
NA	GND	K30		
NA	GND	K20		
NA	GND	K10		
NA	GND	J31		
NA	GND	J9		
NA	GND	H32		
NA	GND	H23		
NA	GND	H17		
NA	GND	H8		
NA	GND	G33		
NA	GND	G20		
NA	GND	G7		
NA	GND	F34		
NA	GND	F6		
NA	GND	E35		
NA	GND	E26		
NA	GND	E14		
NA	GND	E5		
NA	GND	D36		
NA	GND	D23		
NA	GND	D20		
NA	GND	D17		

Table 14: BF957 — XC2V2000, XC2V3000, XC2V4000, and XC2V6000

Bank	Pin Description	Pin Number	No Connect in XC2V2000
5	IO_L73P_5	AJ20	
5	IO_L72N_5	AG18	
5	IO_L72P_5	AG19	
5	IO_L71N_5	AF18	
5	IO_L71P_5	AF19	
5	IO_L70N_5	AK20	
5	IO_L70P_5	AK21	
5	IO_L69N_5/VREF_5	AH20	
5	IO_L69P_5	AH21	
5	IO_L68N_5	AD19	
5	IO_L68P_5	AD20	
5	IO_L67N_5	AL21	
5	IO_L67P_5	AL22	
5	IO_L54N_5	AG20	
5	IO_L54P_5	AG21	
5	IO_L53N_5	AB19	
5	IO_L53P_5	AB20	
5	IO_L52N_5	AJ21	
5	IO_L52P_5	AJ22	
5	IO_L51N_5/VREF_5	AF20	
5	IO_L51P_5	AF21	
5	IO_L50N_5	AE20	
5	IO_L50P_5	AE21	
5	IO_L49N_5	AK22	
5	IO_L49P_5	AK23	
5	IO_L30N_5	AJ23	NC
5	IO_L30P_5	AJ24	NC
5	IO_L29N_5	AC20	NC
5	IO_L29P_5	AC21	NC
5	IO_L28N_5	AL23	NC
5	IO_L28P_5	AL24	NC
5	IO_L27N_5/VREF_5	AL25	NC
5	IO_L27P_5	AL26	NC
5	IO_L26N_5	AD21	NC
5	IO_L26P_5	AD22	NC
5	IO_L25N_5	AH23	NC
5	IO_L25P_5	AH24	NC
5	IO_L24N_5	AG22	