



Welcome to [E-XFL.COM](http://E-XFL.COM)

**Embedded - Microcontrollers - Application Specific: Tailored Solutions for Precision and Performance**

**Embedded - Microcontrollers - Application Specific** represents a category of microcontrollers designed with unique features and capabilities tailored to specific application needs. Unlike general-purpose microcontrollers, application-specific microcontrollers are optimized for particular tasks, offering enhanced performance, efficiency, and functionality to meet the demands of specialized applications.

**What Are Embedded - Microcontrollers - Application Specific?**

Application specific microcontrollers are engineered to

#### Details

Product Status	Active
Applications	Network Processor
Core Processor	MIPS32® 34Kc™
Program Memory Type	SRAM
Controller Series	-
RAM Size	-
Interface	I <sup>2</sup> C, RMII, UART
Number of I/O	-
Voltage - Supply	-
Operating Temperature	-
Mounting Type	Surface Mount
Package / Case	-
Supplier Device Package	896-FCBGA (31x31)
Purchase URL	<a href="https://www.e-xfl.com/product-detail/microchip-technology/wp3232m5nhei-320b2">https://www.e-xfl.com/product-detail/microchip-technology/wp3232m5nhei-320b2</a>

# WP3 WinPath3

## Next Generation Access Systems Packet Processor

Released Product Brief



### Product Overview

The WinPath3, with its enhanced carrier-grade software, is the third generation of WinPath products. Building on hundreds of successful communications systems deployments, the WinPath3 extends PMC's proven formula of complete protocol solutions to a significantly higher level of performance.

The WinPath3 integrates control plane and enhanced data plane processing components. Control plane processing is based on two high-performance MIPS 34K multi-threaded processors. Data plane processing uses new hardware accelerators for packet classification, hierarchical shaping, additional security standards and more to off-load common processing tasks. The accelerators are flexibly combined with a field-proven, fully-programmable, high-performance multi-threaded multi-core data path processor subsystem. 12 cores are available (up from 6 in the WinPath2) and operating speed has increased.

### Benefits

- Enhanced interfaces with on-chip SERDES and the latest memory interfaces for lowered BOM costs and simple system integration
- Straightforward upgrade of WinPath2 applications for improved performance and capability of next-generation access systems
- Minimum design risk, short time-to-market, and lowered costs for new or migrated systems
- Production-hardened protocols supplied royalty-free
- LTE Access and Transport protocols and WiMAX, which generally require significant OEM and deployment customization, fully supported by royalty-free source licensing

The WinPath3 leverages a broad set of supplied protocols developed for WinPath1 and WinPath2, including support for L2 and L3 termination (Ethernet, ML-PPP, IMA, CES), PWE3 (Ethernet, TDM, HDLC, ATM), Packet Network Synchronization (IEEE 1588v2, Synchronous Ethernet, adaptive and differential clock recovery), interworking (MPLS, IPv4/IPv6 Routing, VLAN-aware bridging), OAM (Ethernet, ATM), QoS (policing, shaping, per-flow queuing, WRED) and more.

### Product Highlights

- Third generation family of communication processors provided with carrier-class IP protocol and interworking software
- 5x performance, higher integration than 2nd-generation WinPath2
- Extensive set of interfaces supports IP up to 10 GbE and TDM/SDH up to OC-48 unchannelized or channelized (via companion UFE412/448 device)
- System bus interfaces include PCIe, integrated SERDES
- Highly flexible integrated DDR and Flash memory controllers
- Powerful multi-threaded, multi-core acceleration with RAM-based code store supports evolving standards in Wireline (Carrier Ethernet, Enterprise Access, Mobile Backhaul, GPON, DSLAM) and Wireless (LTE, WiMAX, Fixed Wireless Access) systems
- Data path software is royalty-free and carrier-class supported with a C-language API for rapid system integration for over 60 protocols
- Available data path software supports networking at Layer 2 and above, interworking, QoS, and protocols such as MPLS, MPLS-TP, PB, PBB, EFM G.Bond, PWE3-SATOP, Link Aggregation, GRE, WRED, WFQ, VLAN-aware bridging and many others
- Rich suite of development tools and source code licensing options supports customer-specific requirements

### Block Diagram

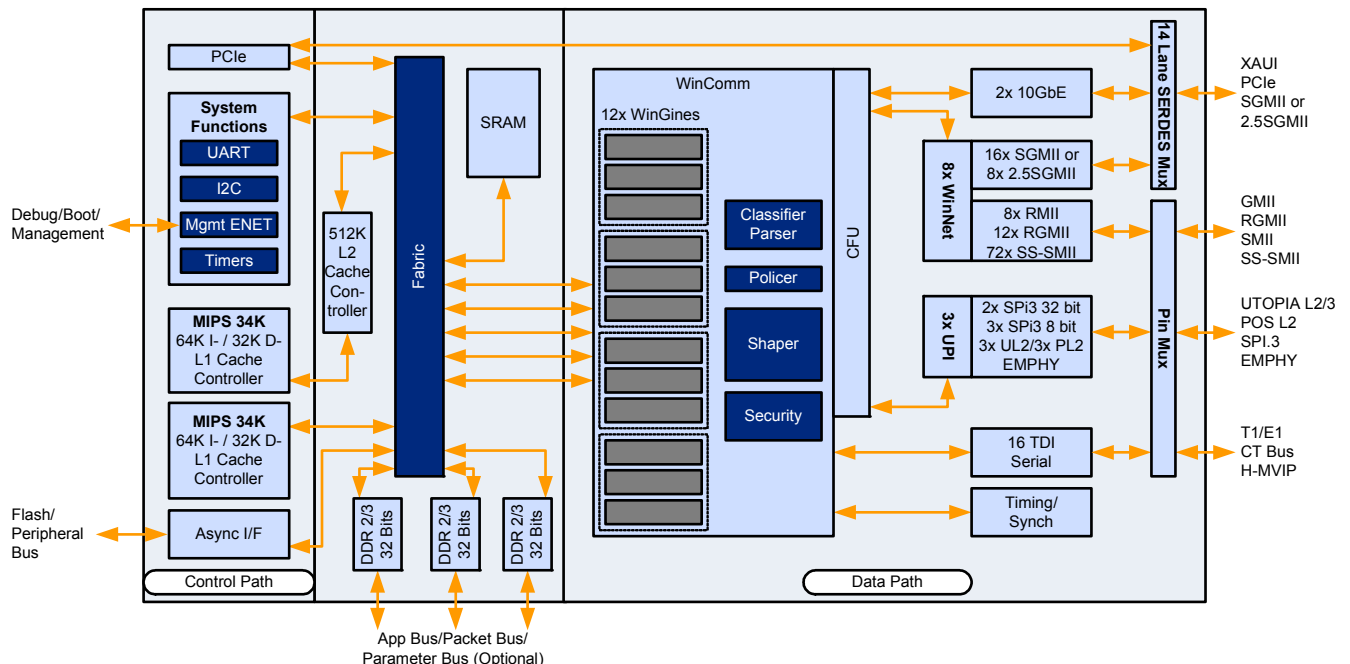

# WP3 WinPath3 Next Generation Access Systems Packet Processor

## RISC Control Processors

- Integrated dual multi-threaded MIPS 34Kc cores at 650 MHz with individual 64K-I/32K-D caches and a 256-KByte or 512-Kbyte L2 cache for one core
- Control processor can be disabled or processing can be shared with external core

## Data Path Processors

- Up to 12 RISC processors and 64 concurrent hardware threads processing at up to 450 MHz
- Provides up to 10 Gbit/s simplex Ethernet based Routing/Bridging application performance for 64-Byte minimum-sized packets, (15M packets per second), including classification, policing and shaping

## New Hardware Accelerators

- Packet classifier (wire speed classification on all interfaces) with 32K rules, including bridging support with up to 16K forwarding rules; up to 450M classification searches per second
- Policing accelerator supporting dual leaky bucket for up to 64K flows
- 3-level hierarchical shaper with 16K Flows with WRED accelerators
- Two Security Accelerators (AES, 3xDES, Kasumi, Snow-3G, H-MAC SHA-1/2, MD5, etc.) with True RNG
- Synchronization over packet networks: adaptive, differential, IEEE 1588v2, Synchronous Ethernet

## Bus and Memory Interfaces

- 3x 16-bit/32-bit DDR2/3 @1200 Mbit/s per pin, (600 MHz, 1200 MTps)
- 2.5 MB internal memory
- NAND, I2C, NOR Flash memory support
- Asynchronous peripheral bus
- One PCIe v1.1 interface

## WinComm Serial Interfaces

- 8 WinNet, supporting combinations of:
  - 16x GbE (SGMII or RGMII or GMII or RTBI)
  - 8x 2.5GbE (Over-clocked SGMII @ 3.125 Gbit/s)
  - 72x ENET ENET 10/100 (SMII/SS-SMII), or 8x RGMII II
- Two 10GbE MACs (XAUI interface)
- Three UPI supporting 3x UL2/PL2, 3x/2x SPI3/UL3 (8-/32-bit) and EMPHY (16-/32-bit for connection to UFE FPGA)
- 16 TDI supporting T1/E1/T3/E3 or CTCT/MVIP bus
- 14 multi-standard SERDES lanes shared between SGMII, over-clocked SGMII, XAUI, and PCIe can directly drive backplane busses

## Host Serial Interfaces

- UART ART, I2C, RMII Management Ethernet Port

## Physical

- 31mm x 31mm 896 FCBGA with 1mm ball pitch
- Low power consumption: 4.5-9.5 W nominal, depending on configuration

## Reference Boards

The WinPath3 family is supported with WDS3 reference boards for early software development while a customer's own board is being developed. WDS3 boards are also valuable for verifying functionality when migrating to new software releases and for duplicating system conditions for support purposes. WDS3 boards are offered standalone and in standard ATCA form factors, so they can be used with any ATCA chassis. They are available with various I/O options and adapter cards to provide equivalent configurations for a range of applications.

## WinPath3 Software

Layer 2 and 3 Interworking		
MPLS	Bridging	PB (VLAN Stacking)
PBB (MAC in MAC)	IPv4 Routing	IPv6 Routing
Packet/Switching	Fast Re-Route	Dynamic Field Classifier
PPPoA/PPPoE	IEEE 1588v2	Synchronous Ethernet
NAT/PAT	Multicast	PWE3
GRE	GTP	L2TP
Programmable Header Manipulation (Remarking, Editing)		
Quality of Service (QoS)		
Ethernet OAM	BFD/CCV	Packet Classification
Per-flow Queuing	Weighted Fair Queuing	Hierarchical Shaping
Packet Policing	2 Rate - 3 Color Marking	Host Termination
Tail Drop	WRED	Statistics/Billing
Layer 2 Protocols		
Ethernet	PWE3 - CESoPSN	PWE3 - SATOP
MPoTDM (IMA, MC/ML-PPP, ATM, PPP/HDLC)		
RFC2507/8/9	EFM G.Bond	IEEE 802.3ad LAG

## Further Resources

### Technology Webpage

[www.pmcs.com/products/mobile\\_network/](http://www.pmcs.com/products/mobile_network/)

### Technical Documentation

[www.pmcs.com/resources/downloads\\_support.html](http://www.pmcs.com/resources/downloads_support.html)

## About PMC

PMC (Nasdaq:PMCS) is the semiconductor innovator transforming networks that connect, move and store digital content. Building on a track record of technology leadership, we are driving innovation across storage, optical and mobile networks. Our highly integrated solutions increase performance and enable next generation services to accelerate the network transformation. For more information visit [www.pmcs.com](http://www.pmcs.com).

Corporate Head Office:  
PMC-Sierra  
1380 Bordeaux Drive  
Sunnyvale, CA 94089, USA  
Tel: 1.408.239.8000  
Fax: 1.408.492.1157

Operations Head Office:  
PMC-Sierra  
8555 Baxter Place  
Burnaby, BC V5A 4V7 Canada  
Tel: 1.604.415.6000  
Fax: 1.604.415.6200

