



Welcome to [E-XFL.COM](http://E-XFL.COM)

### What is "[Embedded - Microcontrollers](#)"?

"[Embedded - Microcontrollers](#)" refer to small, integrated circuits designed to perform specific tasks within larger systems. These microcontrollers are essentially compact computers on a single chip, containing a processor core, memory, and programmable input/output peripherals. They are called "embedded" because they are embedded within electronic devices to control various functions, rather than serving as standalone computers. Microcontrollers are crucial in modern electronics, providing the intelligence and control needed for a wide range of applications.

### Applications of "[Embedded - Microcontrollers](#)"

#### Details

Product Status	Obsolete
Core Processor	Z8
Core Size	8-Bit
Speed	8MHz
Connectivity	-
Peripherals	HLVD, POR, WDT
Number of I/O	16
Program Memory Size	16KB (16K x 8)
Program Memory Type	OTP
EEPROM Size	-
RAM Size	237 x 8
Voltage - Supply (Vcc/Vdd)	2V ~ 5.5V
Data Converters	-
Oscillator Type	Internal
Operating Temperature	-40°C ~ 125°C (TA)
Mounting Type	Surface Mount
Package / Case	20-SOIC (0.295", 7.50mm Width)
Supplier Device Package	-
Purchase URL	<a href="https://www.e-xfl.com/product-detail/zilog/zgp323has2016c00tr">https://www.e-xfl.com/product-detail/zilog/zgp323has2016c00tr</a>



## Revision History

Each instance in Table 1 reflects a change to this document from its previous revision. To see more detail, click the appropriate link in the table.

**Table 1. Revision History of this Document**

<b>Date</b>	<b>Revision Level</b>	<b>Section</b>	<b>Description</b>	<b>Page #</b>
December 2004	02		Changed low power consumption, STOP and HALT mode current values, deleted mask option note, clarified temperature ranges in Tables 6 and 8 and 10. Added new Tables 9 and 10. Also added Characterization data to Table 11 and changed Program/Erase Endurance value in Table 12.	1,2,10 11,12, 13,14, 15
			Removed Preliminary designation	All
March 2005	03		Minor change to Table 9 Electrical Characteristics. Added 20, 28 and 40-pin CDIP parts in the Ordering Section.	11,90



Figure 34. SCLK Circuit .....	58
Figure 35. Stop Mode Recovery Source .....	59
Figure 36. Stop Mode Recovery Register 2 ((0F)DH:D2–D4, D6 Write Only) ..	61
Figure 37. Watch-Dog Timer Mode Register (Write Only) .....	62
Figure 38. Resets and WDT .....	63
Figure 39. TC8 Control Register ((0D)00H: Read/Write Except Where Noted)	66
Figure 40. T8 and T16 Common Control Functions ((0D)01H: Read/Write) ...	67
Figure 41. T16 Control Register ((0D) 2H: Read/Write Except Where Noted) .	69
Figure 42. T8/T16 Control Register (0D)03H: Read/Write (Except Where Noted) .....	70
Figure 43. Voltage Detection Register .....	71
Figure 44. Port Configuration Register (PCON)(0F)00H: Write Only) .....	72
Figure 45. Stop Mode Recovery Register ((0F)0BH: D6–D0=Write Only, D7=Read Only) .....	73
Figure 46. Stop Mode Recovery Register 2 ((0F)0DH:D2–D4, D6 Write Only)	74
Figure 47. Watch-Dog Timer Register ((0F) 0FH: Write Only) .....	75
Figure 48. Port 2 Mode Register (F6H: Write Only) .....	75
Figure 49. Port 3 Mode Register (F7H: Write Only) .....	76
Figure 50. Port 0 and 1 Mode Register (F8H: Write Only) .....	77
Figure 51. Interrupt Priority Register (F9H: Write Only) .....	78
Figure 52. Interrupt Request Register (FAH: Read/Write) .....	79
Figure 53. Interrupt Mask Register (FBH: Read/Write) .....	79
Figure 54. Flag Register (FCH: Read/Write) .....	80
Figure 55. Register Pointer (FDH: Read/Write) .....	80
Figure 56. Stack Pointer High (FEH: Read/Write) .....	81
Figure 57. Stack Pointer Low (FFH: Read/Write) .....	81
Figure 58. 20-Pin CDIP Package .....	82
Figure 59. 20-Pin PDIP Package Diagram .....	82
Figure 60. 20-Pin SOIC Package Diagram .....	83
Figure 61. 20-Pin SSOP Package Diagram .....	84
Figure 62. 28-Pin SOIC Package Diagram .....	85
Figure 63. 28-Pin CDIP Package Diagram .....	86
Figure 64. 28-Pin PDIP Package Diagram .....	86
Figure 65. 28-Pin SSOP Package Diagram .....	87
Figure 66. 40-Pin PDIP Package Diagram .....	87
Figure 67. 40-Pin CDIP Package Diagram .....	88

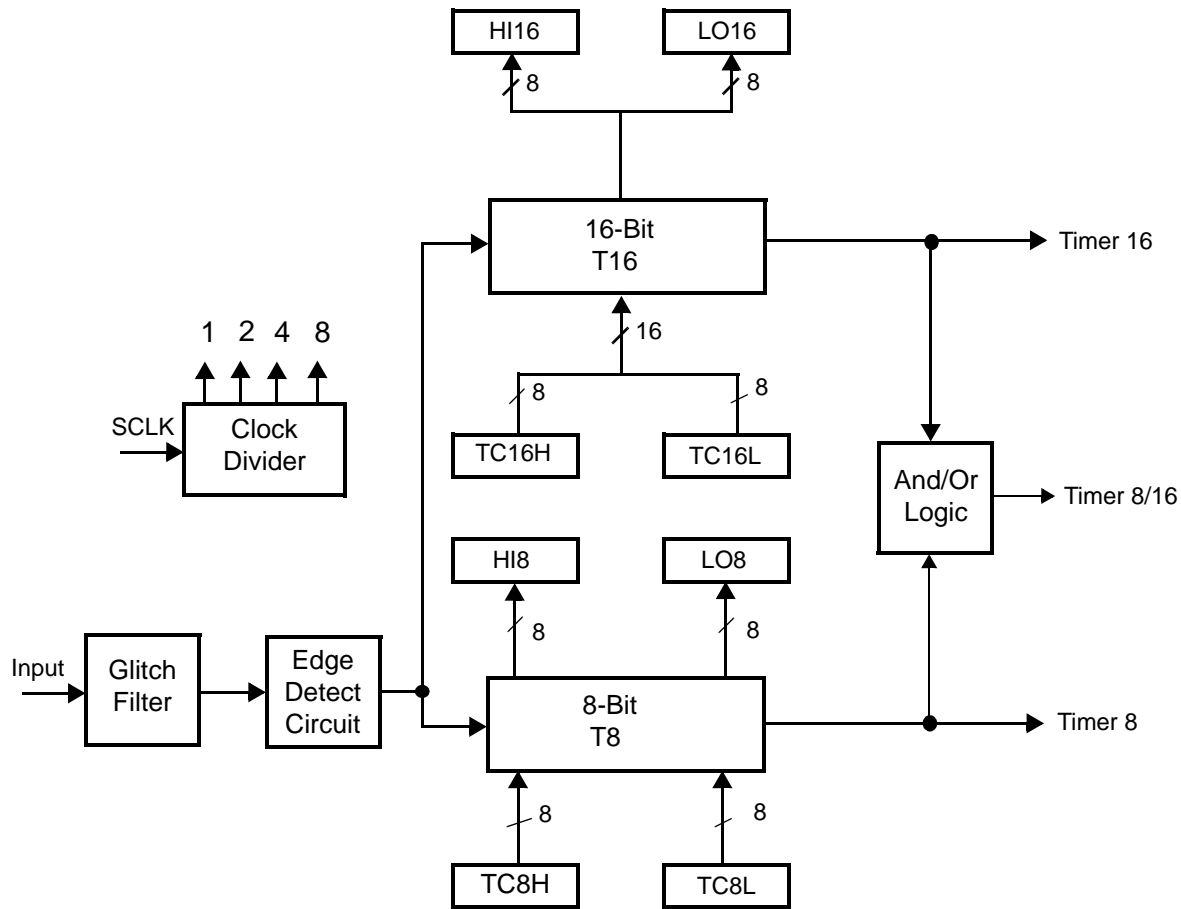

Figure 2. Counter/Timers Diagram

## Pin Description

The pin configuration for the 20-pin PDIP/SOIC/SSOP is illustrated in Figure 3 and described in Table 4. The pin configuration for the 28-pin PDIP/SOIC/SSOP are depicted in Figure 4 and described in Table 5. The pin configurations for the 40-pin PDIP and 48-pin SSOP versions are illustrated in Figure 5, Figure 6, and described in Table 6.

For customer engineering code development, a UV erasable windowed cerdip packaging is offered in 20-pin, 28-pin, and 40-pin configurations. ZiLOG does not recommend nor guarantee these packages for use in production.

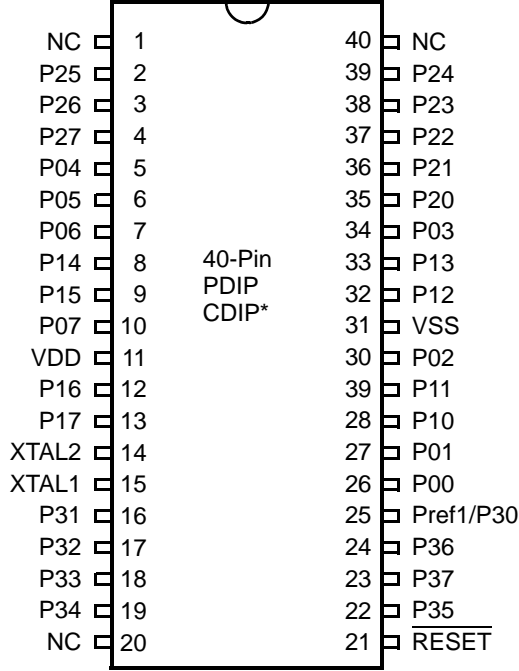

Figure 5. 40-Pin PDIP/CDIP\* Pin Configuration

► **Note:** \*Windowed Cerdip. These units are intended to be used for engineering code development only. ZiLOG does not recommend/guarantee this package for production use.

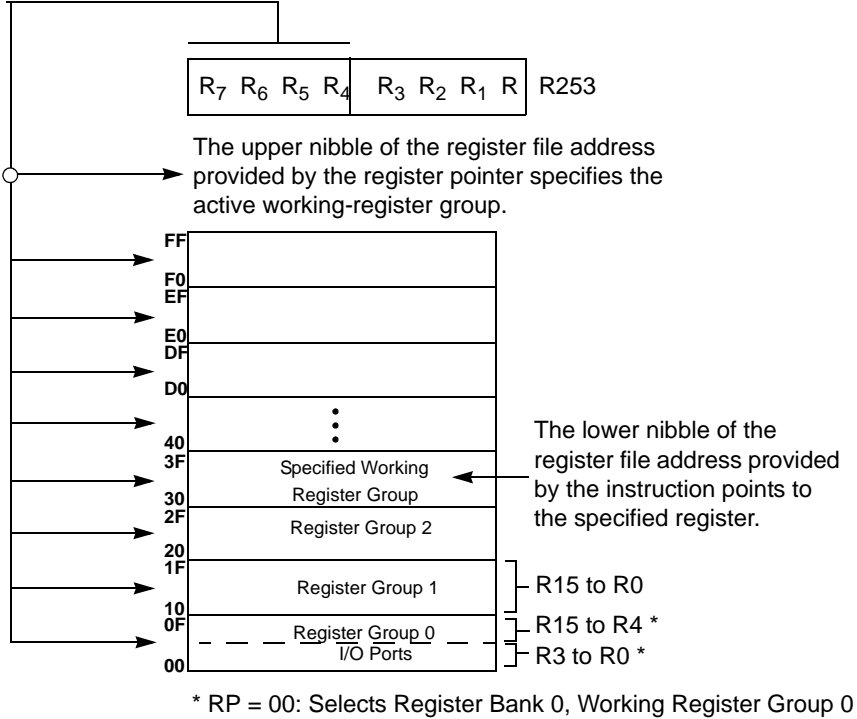

Figure 17. Register Pointer—Detail

**Stack**

The internal register file is used for the stack. An 8-bit Stack Pointer SPL (R255) is used for the internal stack that resides in the general-purpose registers (R4–R239). SPH (R254) can be used as a general-purpose register.

### T8/T16\_Logic/Edge \_Detect

In TRANSMIT Mode, this field defines how the outputs of T8 and T16 are combined (AND, OR, NOR, NAND).

In DEMODULATION Mode, this field defines which edge should be detected by the edge detector.

### Transmit\_Submode/Glitch Filter

In Transmit Mode, this field defines whether T8 and T16 are in the PING-PONG mode or in independent normal operation mode. Setting this field to “NORMAL OPERATION Mode” terminates the “PING-PONG Mode” operation. When set to 10, T16 is immediately forced to a 0; a setting of 11 forces T16 to output a 1.

In DEMODULATION Mode, this field defines the width of the glitch that must be filtered out.

### Initial\_T8\_Out/Rising\_Edge

In TRANSMIT Mode, if 0, the output of T8 is set to 0 when it starts to count. If 1, the output of T8 is set to 1 when it starts to count. When the counter is not enabled and this bit is set to 1 or 0, T8\_OUT is set to the opposite state of this bit. This ensures that when the clock is enabled, a transition occurs to the initial state set by CTR1, D1.

In DEMODULATION Mode, this bit is set to 1 when a rising edge is detected in the input signal. In order to reset the mode, a 1 should be written to this location.

### Initial\_T16 Out/Falling \_Edge

In TRANSMIT Mode, if it is 0, the output of T16 is set to 0 when it starts to count. If it is 1, the output of T16 is set to 1 when it starts to count. This bit is effective only in Normal or PING-PONG Mode (CTR1, D3; D2). When the counter is not enabled and this bit is set, T16\_OUT is set to the opposite state of this bit. This ensures that when the clock is enabled, a transition occurs to the initial state set by CTR1, D0.

In DEMODULATION Mode, this bit is set to 1 when a falling edge is detected in the input signal. In order to reset it, a 1 should be written to this location.

- **Note:** Modifying CTR1 (D1 or D0) while the counters are enabled causes unpredictable output from T8/T16\_OUT.

### CTR2 Counter/Timer 16 Control Register—CTR2(D)02H

Table 17 lists and briefly describes the fields for this register.



In Demodulation Mode, when set to 0, T16 captures and reloads on detection of all the edges. When set to 1, T16 captures and detects on the first edge but ignores the subsequent edges. For details, see the description of T16 Demodulation Mode on page 47.

#### Time\_Out

This bit is set when T16 times out (terminal count reached). To reset the bit, write a 1 to this location.

#### T16\_Clock

This bit defines the frequency of the input signal to Counter/Timer16.

#### Capture\_INT\_Mask

This bit is set to allow an interrupt when data is captured into LO16 and HI16.

#### Counter\_INT\_Mask

Set this bit to allow an interrupt when T16 times out.

#### P35\_Out

This bit defines whether P35 is used as a normal output pin or T16 output.

### CTR3 T8/T16 Control Register—CTR3(D)03H

Table 18 lists and briefly describes the fields for this register. This register allows the T<sub>8</sub> and T<sub>16</sub> counters to be synchronized.

**Table 18. CTR3 (D)03H: T8/T16 Control Register**

Field	Bit Position		Value	Description
T <sub>16</sub> Enable	7-----	R	0*	Counter Disabled
		R	1	Counter Enabled
		W	0	Stop Counter
		W	1	Enable Counter
T <sub>8</sub> Enable	-6-----	R	0*	Counter Disabled
		R	1	Counter Enabled
		W	0	Stop Counter
		W	1	Enable Counter
Sync Mode	--5-----	R/W	0**	Disable Sync Mode
			1	Enable Sync Mode



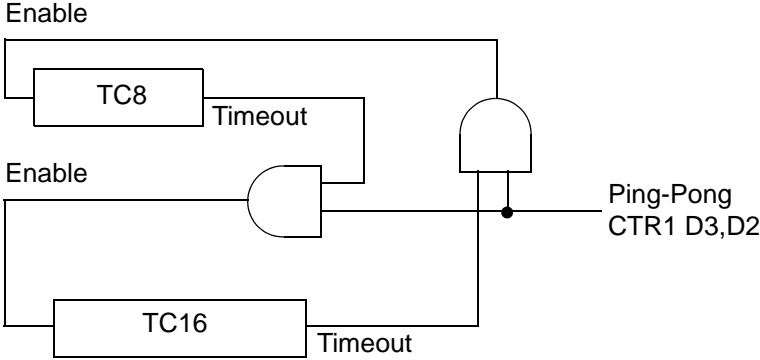

Figure 28. Ping-Pong Mode Diagram

**Initiating PING-PONG Mode**

First, make sure both counter/timers are not running. Set T8 into Single-Pass mode (CTR0, D6), set T16 into SINGLE-PASS mode (CTR2, D6), and set the Ping-Pong mode (CTR1, D2; D3). These instructions can be in random order. Finally, start PING-PONG mode by enabling either T8 (CTR0, D7) or T16 (CTR2, D7). See Figure 29.

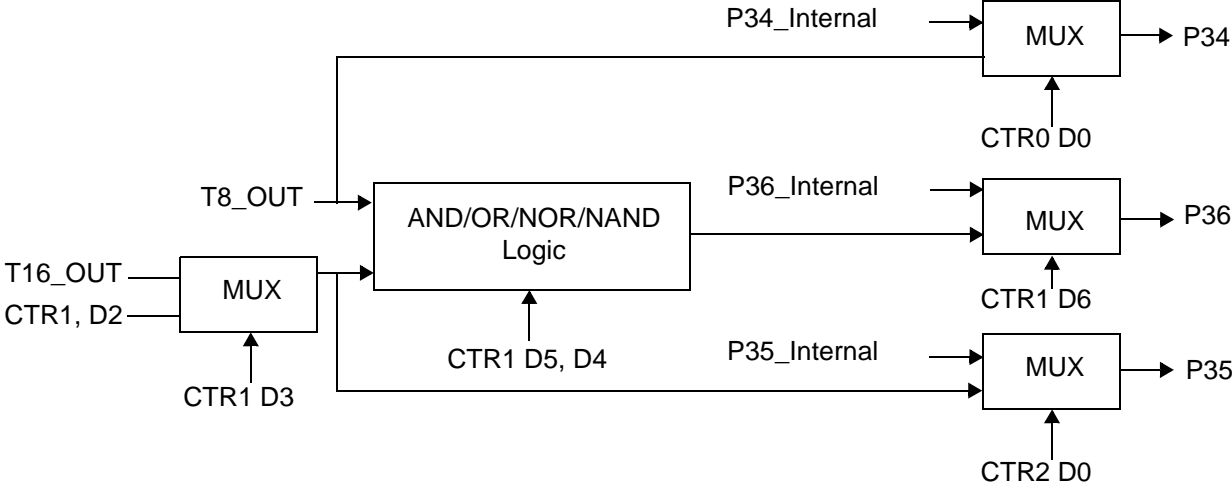
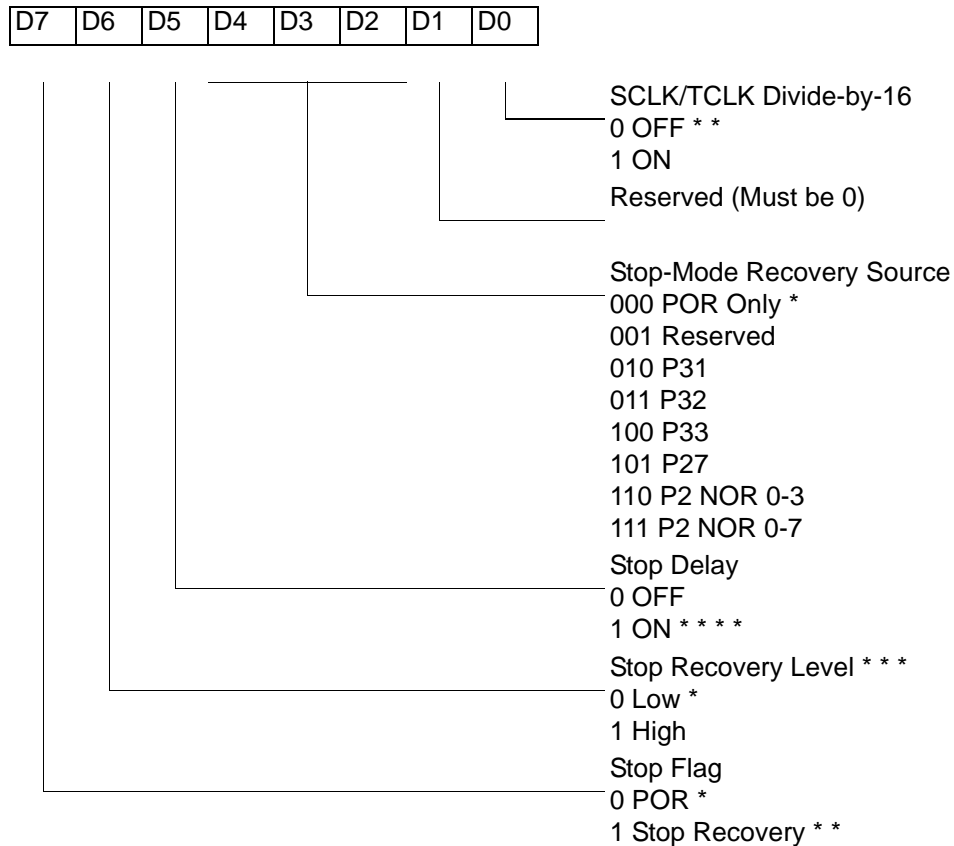

Figure 29. Output Circuit

The initial value of T8 or T16 must not be 1. Stopping the timer and restarting the timer reloads the initial value to avoid an unknown previous value.

SMR(0F)0BH



- \* Default after Power On Reset or Watch-Dog Reset
- \*\* Default setting after Reset and Stop Mode Recovery
- \*\*\* At the XOR gate input
- \*\*\*\* Default setting after reset. Must be 1 if using a crystal or resonator clock source.

**Figure 33. STOP Mode Recovery Register**

**SCLK/TCLK Divide-by-16 Select (D0)**

D0 of the SMR controls a divide-by-16 prescaler of SCLK/TCLK (Figure 34). This control selectively reduces device power consumption during normal processor execution (SCLK control) and/or Halt Mode (where TCLK sources interrupt logic). After Stop Mode Recovery, this bit is set to a 0.





**Watch-Dog Timer Mode Register (WDTMR)**

The Watch-Dog Timer (WDT) is a retriggerable one-shot timer that resets the Z8<sup>®</sup> CPU if it reaches its terminal count. The WDT must initially be enabled by executing the WDT instruction. On subsequent executions of the WDT instruction, the WDT is refreshed. The WDT circuit is driven by an on-board RC-oscillator. The WDT instruction affects the Zero (Z), Sign (S), and Overflow (V) flags.

The POR clock source the internal RC-oscillator. Bits 0 and 1 of the WDT register control a tap circuit that determines the minimum timeout period. Bit 2 determines whether the WDT is active during HALT, and Bit 3 determines WDT activity during Stop. Bits 4 through 7 are reserved (Figure 37). This register is accessible only during the first 60 processor cycles (120 XTAL clocks) from the execution of the first instruction after Power-On-Reset, Watch-Dog Reset, or a Stop-Mode Recovery (Figure 36). After this point, the register cannot be modified by any means (intentional or otherwise). The WDTMR cannot be read. The register is located in Bank F of the Expanded Register Group at address location 0Fh. It is organized as shown in Figure 37.

WDTMR(0F)0Fh

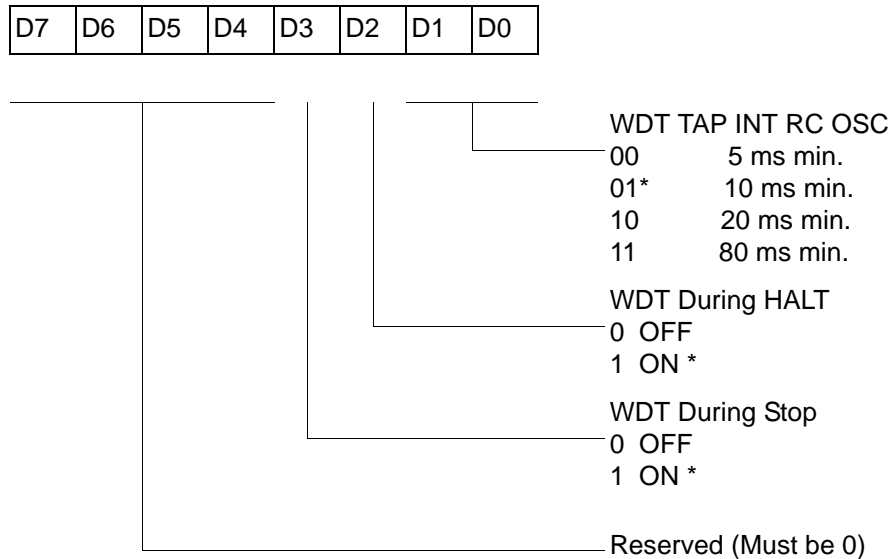

\* Default setting after reset

**Figure 37. Watch-Dog Timer Mode Register (Write Only)**

**WDT Time Select (D0, D1)**

This bit selects the WDT time period. It is configured as indicated in Table 23.

CTR3(0D)03H

D7	D6	D5	D4	D3	D2	D1	D0
----	----	----	----	----	----	----	----

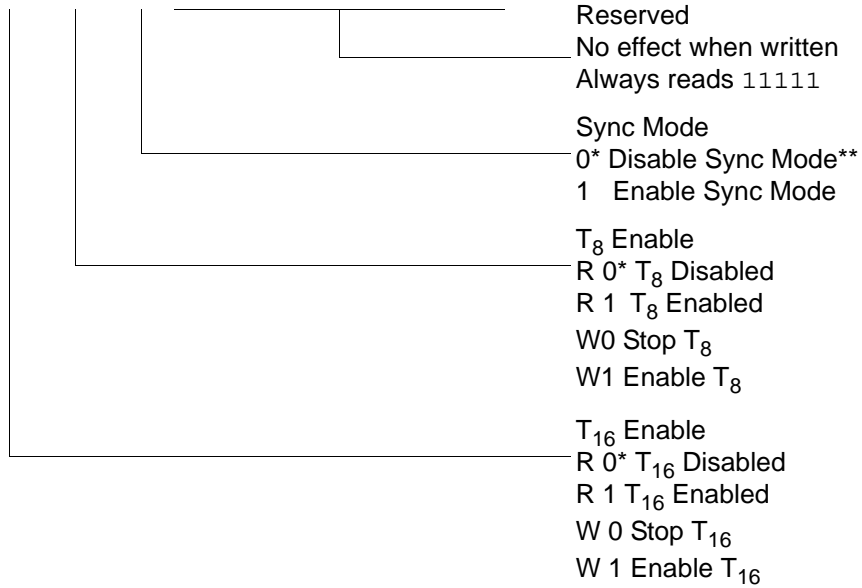

\* Default setting after reset.

\*\* Default setting after reset. Not reset with a Stop Mode recovery.

**Figure 42. T8/T16 Control Register (0D)03H: Read/Write (Except Where Noted)**



R247 P3M(F7H)

D7	D6	D5	D4	D3	D2	D1	D0
----	----	----	----	----	----	----	----

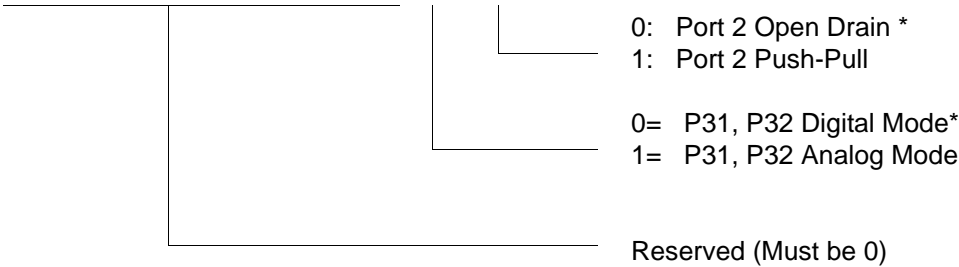

\* Default setting after reset. Not reset with a Stop Mode recovery.

Figure 49. Port 3 Mode Register (F7H: Write Only)

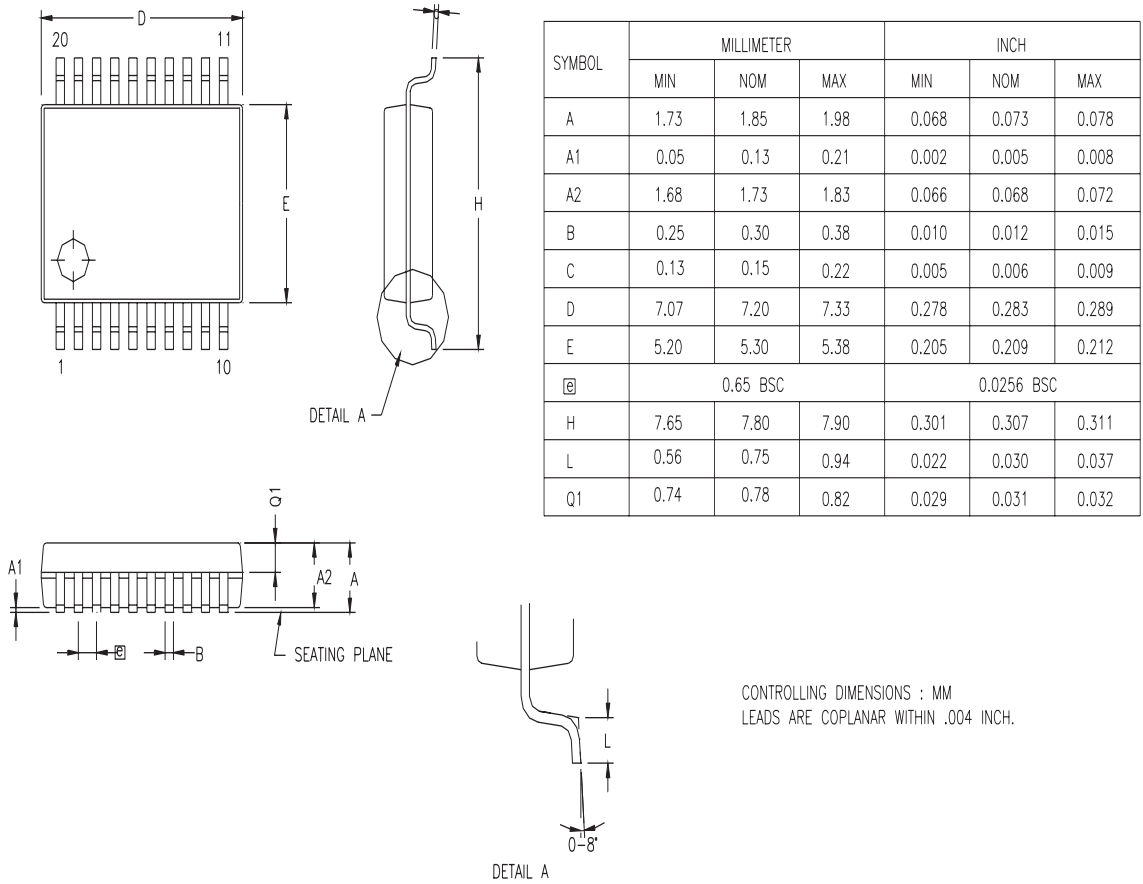

Figure 61. 20-Pin SSOP Package Diagram

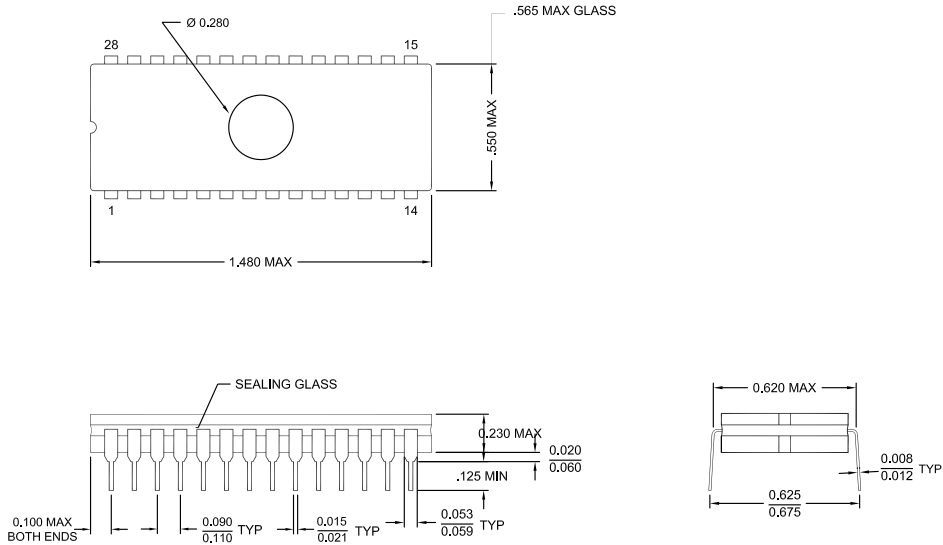
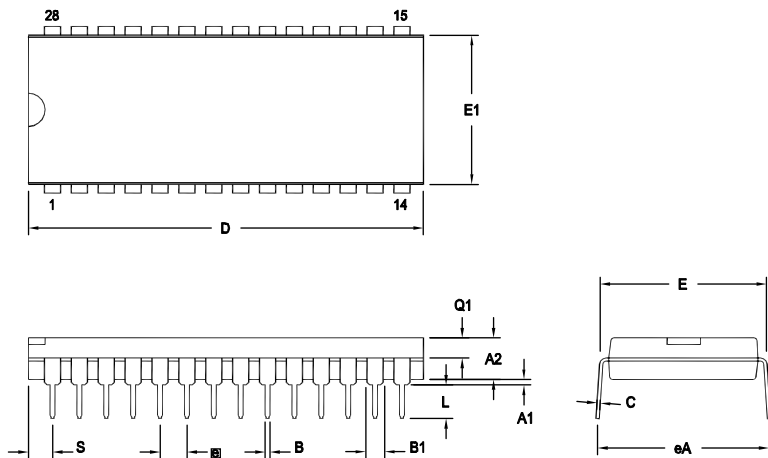

Figure 63. 28-Pin CDIP Package Diagram



SYMBOL	OPT #	MILLIMETER		INCH	
		MIN	MAX	MIN	MAX
A1		0.38	1.02	.015	.040
A2		3.18	4.19	.125	.165
B		0.38	0.53	.015	.021
B1	01	1.40	1.65	.055	.065
	02	1.14	1.40	.045	.055
C		0.23	0.38	.009	.015
D	01	36.58	37.34	1.440	1.470
	02	35.31	35.94	1.390	1.415
E		15.24	15.75	.600	.620
E1	01	13.59	14.10	.535	.555
	02	12.83	13.08	.505	.515
e		2.54 TYP		.100 BSC	
eA		15.49	16.76	.610	.660
L		3.05	3.81	.120	.150
Q1	01	1.40	1.91	.055	.075
	02	1.40	1.78	.055	.070
S	01	1.52	2.29	.060	.090
	02	1.02	1.52	.040	.060

CONTROLLING DIMENSIONS : INCH

OPTION TABLE	
OPTION #	PACKAGE
01	STANDARD
02	IDF

Note: ZILOG supplies both options for production. Component layout PCB design should cover bigger option 01.

Figure 64. 28-Pin PDIP Package Diagram



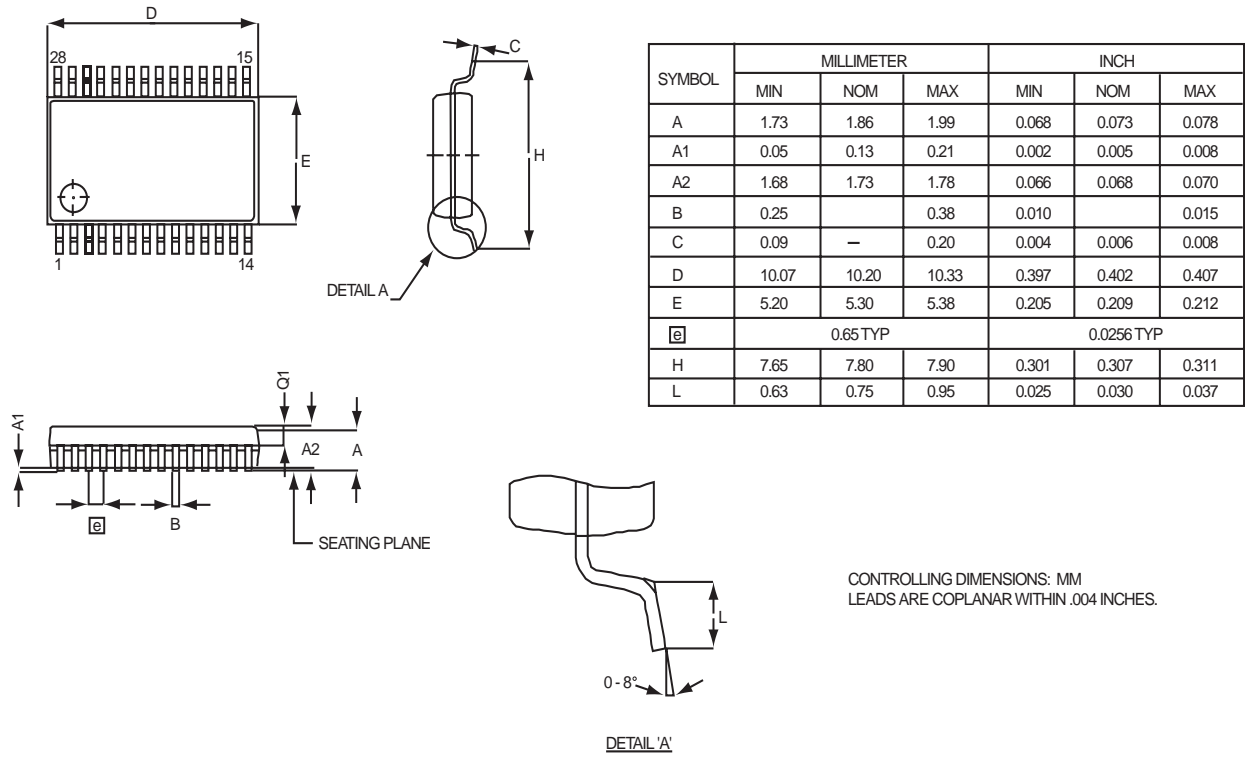

Figure 65. 28-Pin SSOP Package Diagram

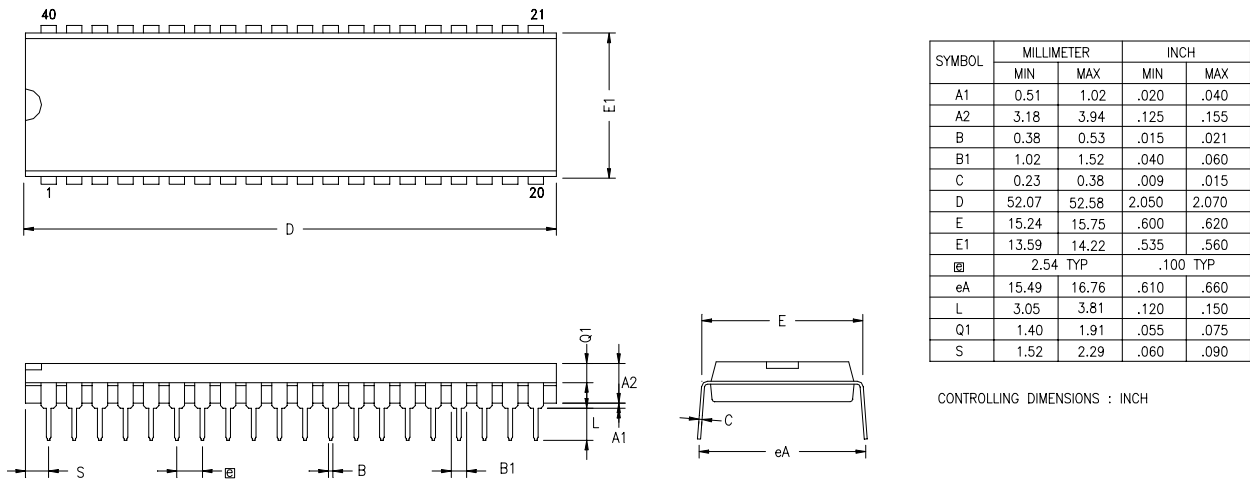
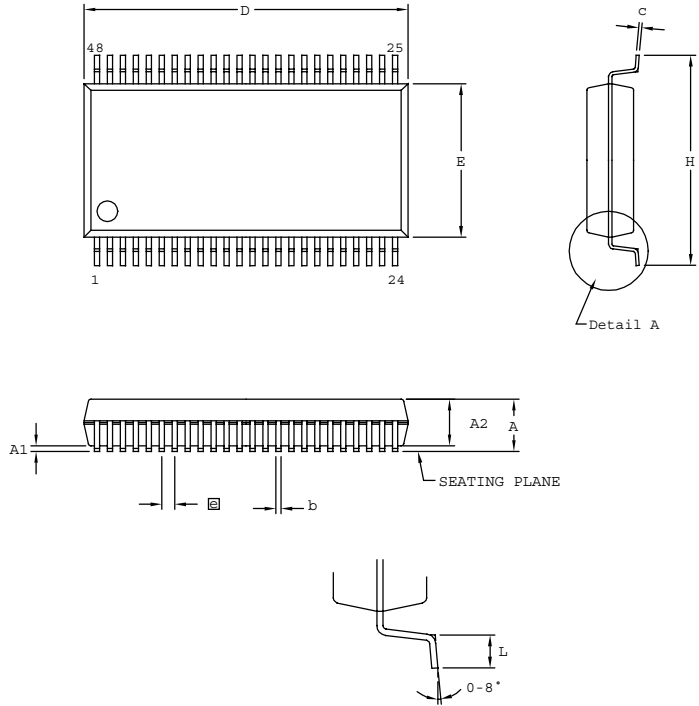

Figure 66. 40-Pin PDIP Package Diagram



SYMBOL	MILLIMETER		INCH	
	MIN	MAX	MIN	MAX
A	2.41	2.79	0.095	0.110
A1	0.23	0.38	0.009	0.015
A2	2.18	2.39	0.086	0.094
b	0.20	0.34	0.008	0.0135
c	0.13	0.25	0.005	0.010
D	15.75	16.00	0.620	0.630
E	7.39	7.59	0.291	0.299
ⓐ	0.635 BSC		0.025 BSC	
H	10.16	10.41	0.400	0.410
L	0.51	1.016	0.020	0.040

CONTROLLING DIMENSIONS : MM  
LEADS ARE COPLANAR WITHIN .004 INCH

Figure 68. 48-Pin SSOP Package Design

► **Note:** Check with ZiLOG on the actual bonding diagram and coordinate for chip-on-board assembly.



## Ordering Information

---



---

### 32KB Standard Temperature: 0° to +70°C

Part Number	Description	Part Number	Description
ZGP323HSH4832C	48-pin SSOP 32K OTP	ZGP323HSS2832C	28-pin SOIC 32K OTP
ZGP323HSP4032C	40-pin PDIP 32K OTP	ZGP323HSH2032C	20-pin SSOP 32K OTP
ZGP323HSK2832E	28-pin CDIP 32K OTP	ZGP323HSK2032E	20-pin CDIP 32K OTP
ZGP323HSK4032E	40-pin CDIP 32K OTP	ZGP323HSP2032C	20-pin PDIP 32K OTP
ZGP323HSH2832C	28-pin SSOP 32K OTP	ZGP323HSS2032C	20-pin SOIC 32K OTP
ZGP323HSP2832C	28-pin PDIP 32K OTP		

---



---

### 32KB Extended Temperature: -40° to +105°C

Part Number	Description	Part Number	Description
ZGP323HEH4832C	48-pin SSOP 32K OTP	ZGP323HES2832C	28-pin SOIC 32K OTP
ZGP323HEP4032C	40-pin PDIP 32K OTP	ZGP323HEH2032C	20-pin SSOP 32K OTP
ZGP323HEH2832C	28-pin SSOP 32K OTP	ZGP323HEP2032C	20-pin PDIP 32K OTP
ZGP323HEP2832C	28-pin PDIP 32K OTP	ZGP323HES2032C	20-pin SOIC 32K OTP

---



---

### 32KB Automotive Temperature: -40° to +125°C

Part Number	Description	Part Number	Description
ZGP323HAH4832C	48-pin SSOP 32K OTP	ZGP323HAS2832C	28-pin SOIC 32K OTP
ZGP323HAP4032C	40-pin PDIP 32K OTP	ZGP323HAH2032C	20-pin SSOP 32K OTP
ZGP323HAH2832C	28-pin SSOP 32K OTP	ZGP323HAP2032C	20-pin PDIP 32K OTP
ZGP323HAP2832C	28-pin PDIP 32K OTP	ZGP323HAS2032C	20-pin SOIC 32K OTP

Replace C with G for Lead-Free Packaging

---

- pin 4
- E
- EPROM
  - selectable options 64
- expanded register file 26
- expanded register file architecture 28
- expanded register file control registers 71
  - flag 80
  - interrupt mask register 79
  - interrupt priority register 78
  - interrupt request register 79
  - port 0 and 1 mode register 77
  - port 2 configuration register 75
  - port 3 mode register 76
  - port configuration register 75
  - register pointer 80
  - stack pointer high register 81
  - stack pointer low register 81
  - stop-mode recovery register 73
  - stop-mode recovery register 2 74
  - T16 control register 69
  - T8 and T16 common control functions register 67
  - T8/T16 control register 70
  - TC8 control register 66
  - watch-dog timer register 75
- F
- features
  - standby modes 1
- functional description
  - counter/timer functional blocks 40
    - CTR(D)01h register 35
    - CTR0(D)00h register 33
    - CTR2(D)02h register 37
    - CTR3(D)03h register 39
  - expanded register file 26
  - expanded register file architecture 28
  - HI16(D)09h register 32
  - HI8(D)0Bh register 32
  - L08(D)0Ah register 32
  - L0I6(D)08h register 32
  - program memory map 26
  - RAM 25
  - register description 65
  - register file 30
  - register pointer 29
  - register pointer detail 31
  - SMR2(F)0D1h register 40
  - stack 31
  - TC16H(D)07h register 32
  - TC16L(D)06h register 33
  - TC8H(D)05h register 33
  - TC8L(D)04h register 33
- G
- glitch filter circuitry 40
- H
- halt instruction, counter/timer 54
- I
- input circuit 40
- interrupt block diagram, counter/timer 51
- interrupt types, sources and vectors 52
- L
- low-voltage detection register 65
- M
- memory, program 25
- modulo-N mode
  - T16\_OUT 47
  - T8\_OUT 43
- O
- oscillator configuration 53
- output circuit, counter/timer 49
- P
- package information
  - 20-pin DIP package diagram 82
  - 20-pin SSOP package diagram 84
  - 28-pin DIP package diagram 86
  - 28-pin SOIC package diagram 85
  - 28-pin SSOP package diagram 87
  - 40-pin DIP package diagram 87
  - 48-pin SSOP package diagram 89
- pin configuration
  - 20-pin DIP/SOIC/SSOP 5

- 28-pin DIP/SOIC/SSOP 6
- 40- and 48-pin 8
- 40-pin DIP 7
- 48-pin SSOP 8
- pin functions
  - port 0 (P07 - P00) 18
  - port 0 (P17 - P10) 19
  - port 0 configuration 19
  - port 1 configuration 20
  - port 2 (P27 - P20) 20
  - port 2 (P37 - P30) 21
  - port 2 configuration 21
  - port 3 configuration 22
  - port 3 counter/timer configuration 24
  - reset) 25
  - XTAL1 (time-based input 18
  - XTAL2 (time-based output) 18
- ping-pong mode 48
- port 0 configuration 19
- port 0 pin function 18
- port 1 configuration 20
- port 1 pin function 19
- port 2 configuration 21
- port 2 pin function 20
- port 3 configuration 22
- port 3 pin function 21
- port 3 counter/timer configuration 24
- port configuration register 55
- power connections 3
- power supply 5
- program memory 25
  - map 26
- R
- ratings, absolute maximum 10
- register 61
  - CTR(D)01h 35
  - CTR0(D)00h 33
  - CTR2(D)02h 37
  - CTR3(D)03h 39
  - flag 80
  - HI16(D)09h 32
  - HI8(D)0Bh 32
  - interrupt priority 78
  - interrupt request 79
  - interruptmask 79
  - L016(D)08h 32
  - L08(D)0Ah 32
  - LVD(D)0Ch 65
  - pointer 80
  - port 0 and 1 77
  - port 2 configuration 75
  - port 3 mode 76
  - port configuration 55, 75
  - SMR2(F)0Dh 40
  - stack pointer high 81
  - stack pointer low 81
  - stop mode recovery 57
  - stop mode recovery 2 61
  - stop-mode recovery 73
  - stop-mode recovery 2 74
  - T16 control 69
  - T8 and T16 common control functions 67
  - T8/T16 control 70
  - TC16H(D)07h 32
  - TC16L(D)06h 33
  - TC8 control 66
  - TC8H(D)05h 33
  - TC8L(D)04h 33
  - voltage detection 71
  - watch-dog timer 75
- register description
  - Counter/Timer2 LS-Byte Hold 33
  - Counter/Timer2 MS-Byte Hold 32
  - Counter/Timer8 Control 33
  - Counter/Timer8 High Hold 33
  - Counter/Timer8 Low Hold 33
  - CTR2 Counter/Timer 16 Control 37
  - CTR3 T8/T16 Control 39
  - Stop Mode Recovery2 40
  - T16\_Capture\_LO 32
  - T8 and T16 Common functions 35
  - T8\_Capture\_HI 32