

Welcome to E-XFL.COM

Understanding [Embedded - Microcontroller, Microprocessor, FPGA Modules](#)

Embedded - Microcontroller, Microprocessor, and FPGA Modules are fundamental components in modern electronic systems, offering a wide range of functionalities and capabilities. Microcontrollers are compact integrated circuits designed to execute specific control tasks within an embedded system. They typically include a processor, memory, and input/output peripherals on a single chip. Microprocessors, on the other hand, are more powerful processing units used in complex computing tasks, often requiring external memory and peripherals. FPGAs (Field Programmable Gate Arrays) are highly flexible devices that can be configured by the user to perform specific logic functions, making them invaluable in applications requiring customization and adaptability.

Applications of [Embedded - Microcontroller,](#)

Details

Product Status	Active
Module/Board Type	MCU Core
Core Processor	eZ80F92
Co-Processor	-
Speed	20MHz
Flash Size	128KB
RAM Size	8KB (Internal), 128KB (External)
Connector Type	Header 2x25
Size / Dimension	2.5" x 2.5" (64mm x 64mm)
Operating Temperature	0°C ~ 70°C
Purchase URL	https://www.e-xfl.com/product-detail/zilog/ez80f920020mod



Warning: DO NOT USE IN LIFE SUPPORT

LIFE SUPPORT POLICY

ZILOG'S PRODUCTS ARE NOT AUTHORIZED FOR USE AS CRITICAL COMPONENTS IN LIFE SUPPORT DEVICES OR SYSTEMS WITHOUT THE EXPRESS PRIOR WRITTEN APPROVAL OF THE PRESIDENT AND GENERAL COUNSEL OF ZILOG CORPORATION.

As used herein

Life support devices or systems are devices which (a) are intended for surgical implant into the body, or (b) support or sustain life and whose failure to perform when properly used in accordance with instructions for use provided in the labeling can be reasonably expected to result in a significant injury to the user. A critical component is any component in a life support device or system whose failure to perform can be reasonably expected to cause the failure of the life support device or system or to affect its safety or effectiveness.

Document Disclaimer

©2008 by Zilog, Inc. All rights reserved. Information in this publication concerning the devices, applications, or technology described is intended to suggest possible uses and may be superseded. ZILOG, INC. DOES NOT ASSUME LIABILITY FOR OR PROVIDE A REPRESENTATION OF ACCURACY OF THE INFORMATION, DEVICES, OR TECHNOLOGY DESCRIBED IN THIS DOCUMENT. ZILOG ALSO DOES NOT ASSUME LIABILITY FOR INTELLECTUAL PROPERTY INFRINGEMENT RELATED IN ANY MANNER TO USE OF INFORMATION, DEVICES, OR TECHNOLOGY DESCRIBED HEREIN OR OTHERWISE. The information contained within this document has been verified according to the general principles of electrical and mechanical engineering.

eZ80 and eZ80Acclaim! are registered trademarks of Zilog, Inc. All other product or service names are the property of their respective owners.



**ISO 9001:2000
FS 507510**

Zilog products are designed and manufactured under an ISO registered 9001:2000 Quality Management System. For more details, please visit www.zilog.com/quality.

Revision History

Each instance in Revision History reflects a change to this document from its previous revision. For more details, refer to the corresponding pages and appropriate links in the table below.

Date	Revision Level	Description	Page Number
September 2008	06	Removed Preliminary. Updated as per latest template and style guide changes.	All
December 2003	05	Fixed incorrect conditional indicators.	All
August 2003	04	Modified to remove zservice@zillog.com and other external hyperlinks to documentation.	All
February 2003	03	Fixed incorrect hyperlinks.	All
January 2003	02	Modified references for eZ80Acclaim!®.	All

Table of Contents

Architectural Overview	1
eZ80F92 Flash Module Features	1
eZ80F92 Flash Module Bill of Materials	2
eZ80F92 Controller Features	4
Block Diagram	5
Pin Description	6
Peripheral Bus Connector	6
I/O Connector	9
Onboard Component Description	13
Logic-Level I/Os	13
Onboard Battery Backup	13
Memory	13
Wait States	13
Static RAM	14
Flash Memory	14
IrDA Transceiver	14
Reset Generator	15
Serial Interface Ports	15
Physical Dimensions	16
Mounting the Module onto the eZ80® Development Platform	18
ESD/EMI Protection	19
Absolute Maximum Ratings	19
Power Supply	20
Schematics	21
Customer Support	30

Architectural Overview

Zilog's eZ80F92 Flash Module is a low-cost, general-purpose compact module. It is specially designed for the rapid development and deployment of embedded systems. This expandable module is powered by Zilog's latest power-efficient, high-speed, optimized pipeline architecture eZ80F92 Microcontroller Unit (MCU). This MCU, the first device in Zilog's eZ80Acclaim![®] product line, features 128 KB of on-chip Flash memory and 8 KB of on-chip SRAM.

The eZ80F92 MCU is a high-speed, single-cycle instruction-fetch MCU, which can operate with a clock speed of 20 MHz. It can operate in Z80[®]-compatible addressing mode (64 KB) or full 24-bit addressing mode (16 MB).

The rich peripheral set of the eZ80F92 Flash Module makes it suitable for a variety of applications, including industrial control, IrDA connectivity, communication, security, automation, point-of-sale (POS) terminals.

- **Note:** *The eZ80F92 Flash Module incorporates the eZ80F92 MCU. The eZ80F92 can be replaced with the eZ80F93 MCU, which features 64 KB of internal Flash memory and 4 KB of internal SRAM.*

eZ80F92 Flash Module Features

The key features of eZ80F92 Flash Module include:

- eZ80Acclaim! Flash MCU with factory-default operating clock frequency at 20 MHz
- 512 KB zero-wait-state onboard SRAM
- 128 KB on-chip Flash memory
- GoldCap backup for Real-Time Clock (RTC)
- Input/Output (I/O) connector provides 24 general-purpose 5V-tolerant I/O pinouts
- Zilog's industry-leading IrDA transceiver—Zilog's ZHX1810
- I/O circuit Flash programming circuitry
- Onboard connector provides I²C 2-wire SDA/SCL interface
- Onboard connector provides I/O bus for external peripheral connections (IRQ, \overline{CS} , 24 address, 8 data)
- Low-cost adaptation to carrier board via two 2 x 25 pin (2.54 mm) headers
- Horizontal or vertical mounting onto the eZ80[®] Development Platform
- Small footprint 64 x 64 mm
- 3.3 V power supply
- Standard operating temperature range: 0 °C to +70 °C

Table 1. Bill of Materials for the eZ80F92 Flash Module (Continued)

Part Number	Part Name	Qty.	Jumper Location	Manufacturer
46-3001-03	Resistor, 10 k Ω , 1%, 1/16W, 0603 SMT	9	R1, 11, 12, 17, 19, 29, 30, 34, 36	Sprague 420CK472X2PD
46-3000-00	Resistor, 0 Ω , 1%, 1/16W, 0603 SMT	2	R2, C25	"
46-3000-71	Resistor, 2.21 k Ω , 1%, 1/16W, 0603 SMT	3	R3, R10, R33	"
46-3000-35	Resistor, 68 Ω , 1%, 1/16W, 0603 SMT	1	R5	"
46-1005-03	Resistor, 2.7 Ω , 5%, 1/4W, 1206 SMT	1	R6	"
46-3001-03	Resistor, 4.75 k Ω , 1%, 1/16W, 0603 SMT	4	R7, 8, 13, 22	"
46-3000-27	Resistor, 33.2 Ω , 1%, 1/16W, 0603 SMT	1	R9	"
46-3000-39	Resistor, 100 Ω , 1%, 1/16W, 0603 SMT	5	R20, 21, 26, 28, 32	"
46-3000-80	Resistor, 4.99 k Ω , 1%, 1/16W, 0603 SMT	1	R23	"
46-3000-07	Resistor, 8.2 Ω , 1%, 1/16W, 0603 SMT	2	R24, R25	"
46-3001-51	Resistor, 1M Ω , 1%, 1/16W, 0603 SMT	1	R27	"
23-0000-10	Internal crystal, 20.0000 MHz, SER/RESN, HC-49S	2	Y1, Y2	Fox Series HC-49S 20.0000 MHz
23-0006-00	Internal crystal, 32.768 kHz, SER/RESN, TF CASE	1	Y3	NDK MX-38
21-0055-02	Connector, HDR/PIN,. 025SQ, double row	2	JP1, JP2	"

Pin Description

Peripheral Bus Connector

Figure 2 displays the pin layout of the eZ80F92 Flash Module’s I/O Connector (JP1) in the 50-pin package. Table 2 on page 7 lists the pins and their functions.

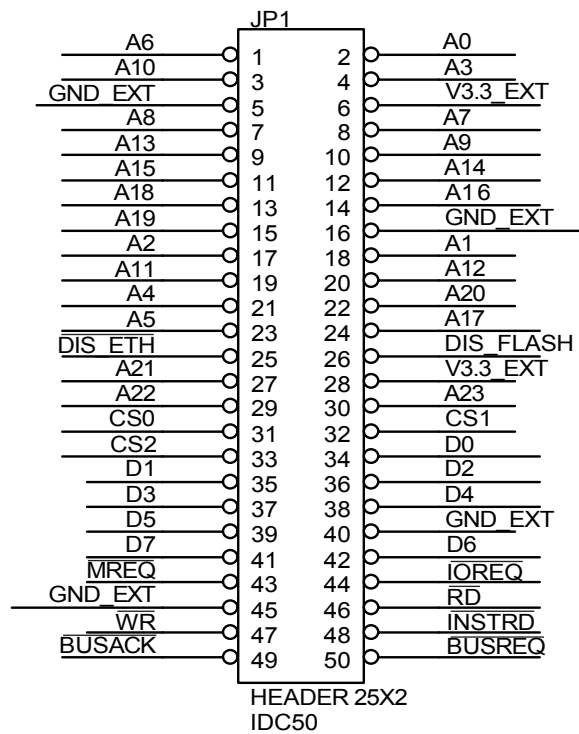

Figure 2. eZ80F92 Flash Module Peripheral Bus Connector Pin Configuration

Table 2. eZ80F92 Flash Module Peripheral Bus Connector Pin Identification* (Continued)

Pin No.	Symbol	Pull Up/Down*	Signal Direction	Comments
27	A21		Bidirectional	
28	V _{DD}			3.3 V supply input pin.
29	A22		Bidirectional	
30	A23		Bidirectional	
31	$\overline{\text{CS0}}$		Output	
32	$\overline{\text{CS1}}$		Output	
33	$\overline{\text{CS2}}$		Output	
34	D0	PU 4k7	Bidirectional	
35	D1	PU 4k7	Bidirectional	
36	D2	PU 4k7	Bidirectional	
37	D3	PU 4k7	Bidirectional	
38	D4	PU 4k7	Bidirectional	
39	D5	PU 4k7	Bidirectional	
40	GND			V _{SS} /Ground (0 V).
41	D7	PU 4k7	Bidirectional	
42	D6		Bidirectional	
43	$\overline{\text{MREQ}}$		Bidirectional	
44	$\overline{\text{IORQ}}$		Bidirectional	
45	GND			V _{SS} /Ground (0 V).
46	$\overline{\text{RD}}$		Bidirectional	
47	$\overline{\text{WR}}$		Bidirectional	
48	$\overline{\text{INSTRD}}$		Output	
49	$\overline{\text{BUSACK}}$		Output	
50	$\overline{\text{BUSREQ}}$	PU 2k2	Input	

* External capacitive loads on $\overline{\text{RD}}$, $\overline{\text{WR}}$, $\overline{\text{IORQ}}$, $\overline{\text{MREQ}}$, D0–D7, and A0–A23 should be below 10 pF to satisfy timing requirements for the CPU. All unused inputs should be pulled to either V_{DD} or GND, depending on their inactive levels to reduce power consumption and to reduce noise sensitivity. To prevent EMI, the eZ80CLK output can be deactivated via software in the eZ80F92 Peripheral Power-Down Register. All inputs are CMOS level 3.3 V (5 V tolerant), except otherwise noted.

I/O Connector

Figure 3 displays the pin layout of the eZ80F92 Flash Module's I/O Connector (JP2) in the 50-pin package. Table 3 on page 9 lists the pins and their functions.

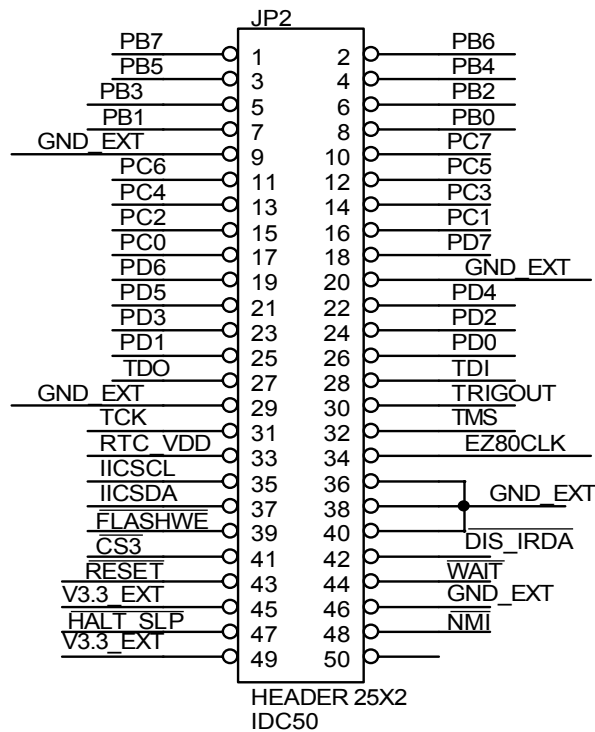

Figure 3. eZ80F92 Flash Module I/O Connector Pin Configuration

Table 3. eZ80F92 Flash Module I/O Connector Pin Identification*

Pin No.	Symbol	Pull Up/Down	Signal Direction	Comments
1	PB7		Bidirectional	
2	PB6		Bidirectional	
3	PB5		Bidirectional	
4	PB4		Bidirectional	
5	PB3		Bidirectional	
6	PB2		Bidirectional	
7	PB1		Bidirectional	

Table 3. eZ80F92 Flash Module I/O Connector Pin Identification* (Continued)

Pin No.	Symbol	Pull Up/Down	Signal Direction	Comments
8	PB0		Bidirectional	
9	GND			V _{SS} /Ground (0 V).
10	PC7		Bidirectional	
11	PC6		Bidirectional	
12	PC5		Bidirectional	
13	PC4		Bidirectional	
14	PC3		Bidirectional	
15	PC2		Bidirectional	
16	PC1		Bidirectional	
17	PC0		Bidirectional	
18	PD7		Bidirectional	
19	PD6		Bidirectional	
20	GND			V _{SS} /Ground (0 V).
21	PD5		Bidirectional	
22	PD4	PD 4k7	Bidirectional	
23	PD3		Bidirectional	
24	PD2		Bidirectional	
25	PD1		Bidirectional	
26	PD0		Bidirectional	
27	TDO		Output	JTAG Data Output pin.
28	TDI/ZDA		Input	JTAG Data Input pin.
	ZDA		Bidirectional	ZDI Data I/O.
29	GND			V _{SS} /Ground (0 V).
30	TRIGOUT		Output	Active High trigger event indicator.
31	TCK	PU 10 kΩ	Input	JTAG Input. High on reset enables ZDI mode; Low on reset enables OCI debug.
32	TMS	PU 10 kΩ	Input	JTAG Test Mode Select Input.
33	RTC_V _{DD}			RTC supply from GoldCap (or external battery).
34	EZ80CLK		Output	20 MHz synchronous CPU clock output.

Table 3. eZ80F92 Flash Module I/O Connector Pin Identification* (Continued)

Pin No.	Symbol	Pull Up/Down	Signal Direction	Comments
35	SCL	PU 4k7	Bidirectional	I ² C Bus Clock.
36	GND			V _{SS} /Ground (0 V).
37	SDA	PU 4k7	Bidirectional	I ² C Data Clock.
38	GND			V _{SS} /Ground (0 V).
39	FlashWE	PU 10 kΩ	Input	This pin has no function on the eZ80F92 Flash Module. It is pulled up to V _{DD} and a connection is available on the external Flash memory pads.
40	GND			V _{SS} /Ground (0V).
41	CS3		Output	Chip select for onboard or external devices; CMOS output 3.3 V.
42	DIS_IRDA	PU 10 kΩ	Input	Low disables onboard IRDA transceiver to use PD0/PD1 UART pins externally.
43	RESET	PU 2k2	Bidirectional	Reset Output from module or push-button reset.
44	WAIT	PU 2k2	Input	Driving the WAIT pin Low forces the CPU to provide additional clock cycles for an external peripheral or external memory to complete its Read or Write operation.
45	V _{DD}			3.3 V supply input pin.
46	GND			V _{SS} /Ground (0 V).
47	HALT_SLP		Output, Active Low	A Low on this pin indicates that the CPU enters either HALT or SLEEP mode because of execution of either a HALT or SLP instruction.
48	NMI	PU 10 kΩ	Schmitt_Trigger Input, Active Low	The NMI input is a higher priority input than the maskable interrupts. It is always recognized at the end of an instruction, regardless of the state of the interrupt enable control bits. This input includes a Schmitt_Trigger to allow RC rise times. This external NMI signal is combined with an internal NMI signal generated from the WDT block before being connected to the NMI input of the CPU.
49	V _{DD}			3.3 V supply input pin.

Onboard Component Description

Logic-Level I/Os

The I/O connector features 24 general-purpose 3.3 V CMOS I/O pins that can be used as outputs or inputs interfacing to external logic. All I/Os are 5 V tolerant. Some of the GPIO pins support dual mode functions (SPI, Timer I/O, UARTs, and bit I/O with edge- or level-triggered interrupt functions on each pin). For more information on eZ80F92 dual modes, refer to *eZ80F92/eZ80F93 Product Specification (PS0153)*.

Onboard Battery Backup

An onboard 0.1 F capacitor (GoldCap) is used to bridge power outages of 2–4 hours if the power supply to the module is disconnected. The capacitor is charged to 3.1 V during normal operation and is discharged through the on-chip RTC. The V_{RTC} pin is available on the I/O connector of the module to connect external components to a power supply or to a larger GoldCap.



Caution: *Do not connect a Lithium Battery to the GoldCap capacitor, because onboard charging circuitry for the capacitor can destroy the lithium battery.*

Memory

The eZ80F92 Flash Module offers external SRAM memory and Flash memories. The wait states selectable in the eZ80F92 MCU's support memory operations, as described in this section.

Wait States

To ensure that valid data is read from or written to slower memories, a number of wait states must be inserted into the memory or I/O access operations by the controller. The number of wait states that are required should be added by programming the chip select control registers. To calculate the minimum number of wait states required, see [Table 4](#).

Table 4. Chip Frequency to Wait State Cycle Time Calculation

MHz	Cycle Time
12	83.3 ns
20	50.0 ns

Reset Generator

The onboard Reset Generator Chip performs reliable Power-On Reset (POR). The chip generates a reset pulse with a duration of 200 ms if the power supply drops below 2.93 V. This reset pulse ensures that the board always starts in a defined condition. The RESET pin on the I/O connector reflects the status of the RESET line. It is a bidirectional pin for resetting external peripheral components or for resetting the eZ80F92 Flash Module with a low-impedance output (for example, a 100 Ω push-button).

Serial Interface Ports

The controller contains two 16550-style UARTs with programmable baud rate generators. UART0 is typically used for console I/O, and initial boot code upload, or to connect remote peripherals that can be controlled and monitored via Ethernet. UART0 is connected to GPIO PD[0:3] on the I/O connector. There are no RS-232 level shifters on the eZ80F92 Flash Module.

► **Note:** *Do not connect an RS-232 interface without level shifters.*

UART1 can be used for modem attachment or as a communications port to a host computer, where the embedded Ethernet module emulates an AT-style modem for internet access. UART1 does not offer onboard RS-232 level shifters.

Figure 5 displays a top view of the eZ80F92 Flash Module.

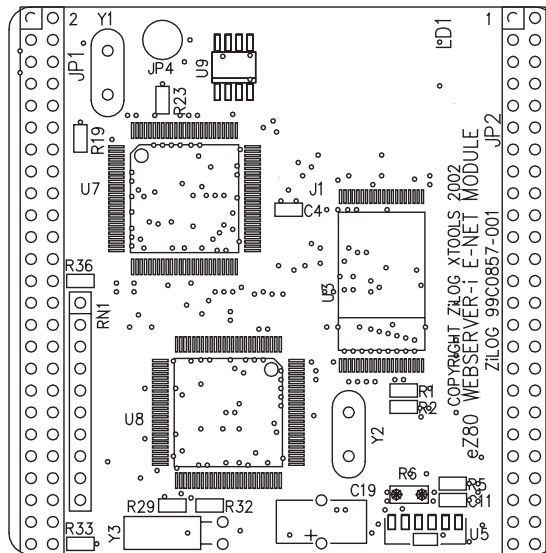

Figure 5. Top Layer

Figure 6 displays a bottom view of the eZ80F92 Flash Module.

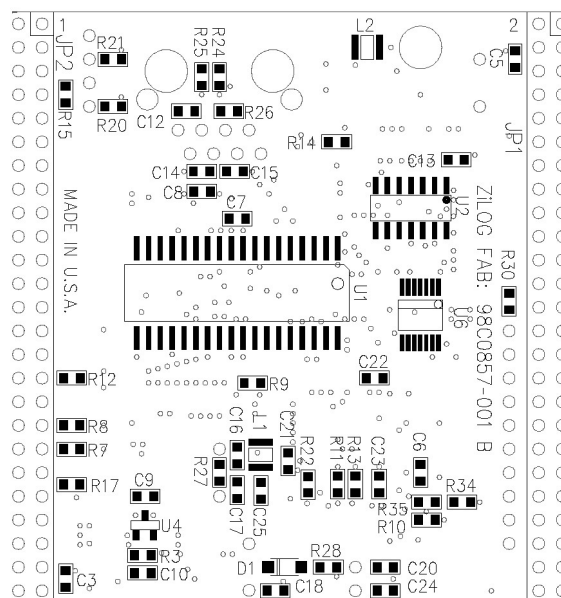

Figure 6. Bottom Layer

ESD/EMI Protection



Caution: *The eZ80F92 Flash Module is a component that is intended to be part of a system design for end-user devices. Therefore, you must take precaution to use ESD protection on the I/O pins.*



Caution: *CMOS I/Os are ESD-sensitive and must be handled with care. Handling of the module should be performed in ESD-safe environments (for example, with a wrist-wrap attached). When developing applications, you must provide for proper ESD protection on external, user-accessible I/Os (for example, suppressor arrays for the I/Os).*

The components are mounted on a multilayer PCB to provide a stable ground plane for onboard components. The module features several GND pins next to pins with higher switching frequency for short ground returns. If unused, the clock output can be separated from the module header by removing a series resistor on the module. Removing the series resistor further reduces electromagnetic emissions.

Absolute Maximum Ratings

Stresses greater than those listed in [Table 5](#) can cause permanent damage to the device. These ratings are stress ratings only. Operation of the device at any condition outside those indicated in the operational sections of these specifications is not implied. Exposure to absolute maximum rating conditions for extended periods may affect device reliability. For improved reliability, unused inputs should be tied to one of the supply voltages (V_{DD} or V_{SS}).

Table 5. Absolute Maximum Ratings

Parameter	Min	Max	Units
Standard operating temperature	0	+70	°C
Storage temperature	-45	+85	°C
Operating Humidity (RH @ 50 °C)	25%	90%	
Operating Voltage ($\pm 5\%$)	—	3.3	V

Schematics

Figure 9 through Figure 17 on page 29 displays the layout of the eZ80F92 Flash Module. Ethernet and external Flash circuiting devices are not loaded on the eZ80F92 Flash Module. However, these devices appear in the following schematics for reference.

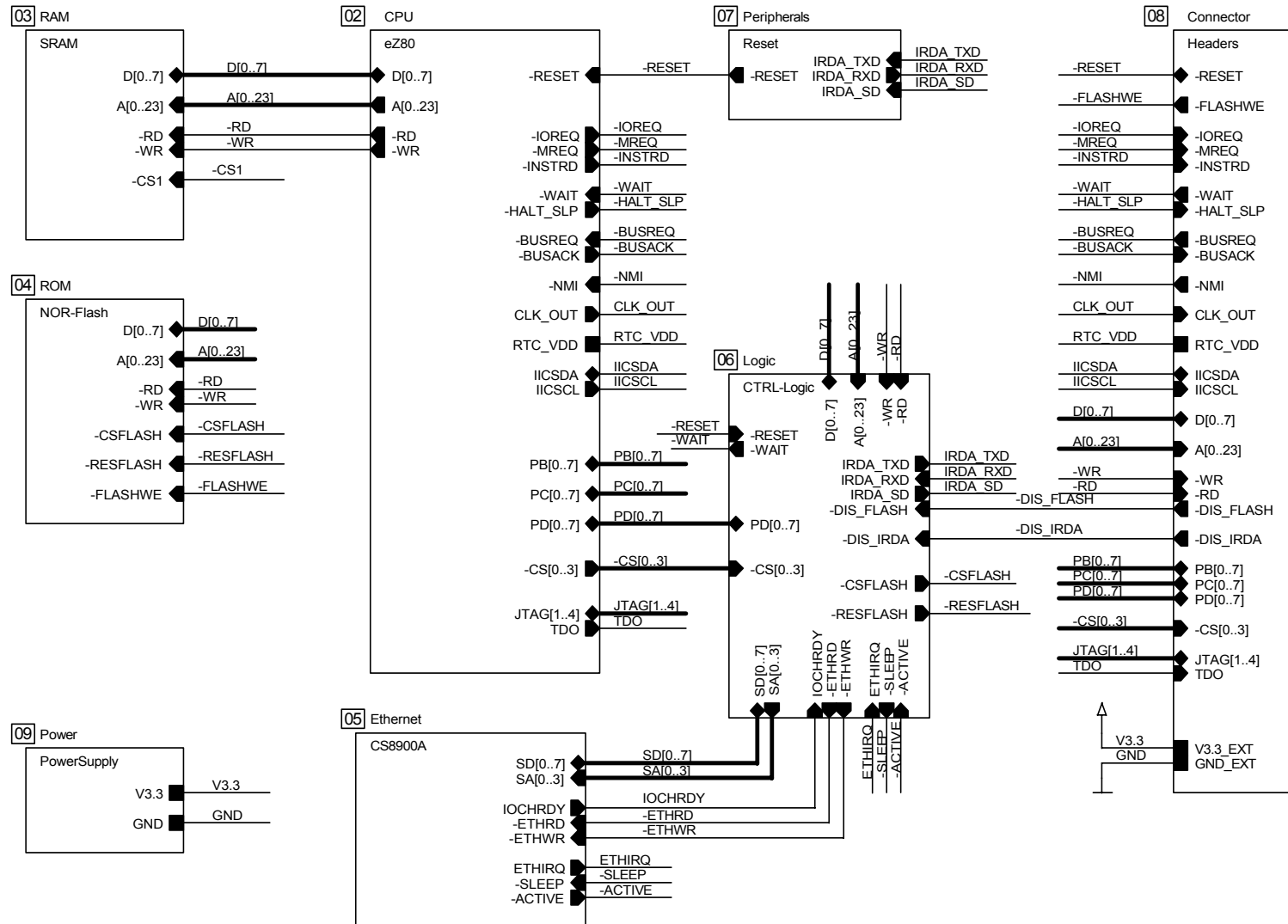

Figure 9. eZ80F92 Flash Module Schematics—Top Level

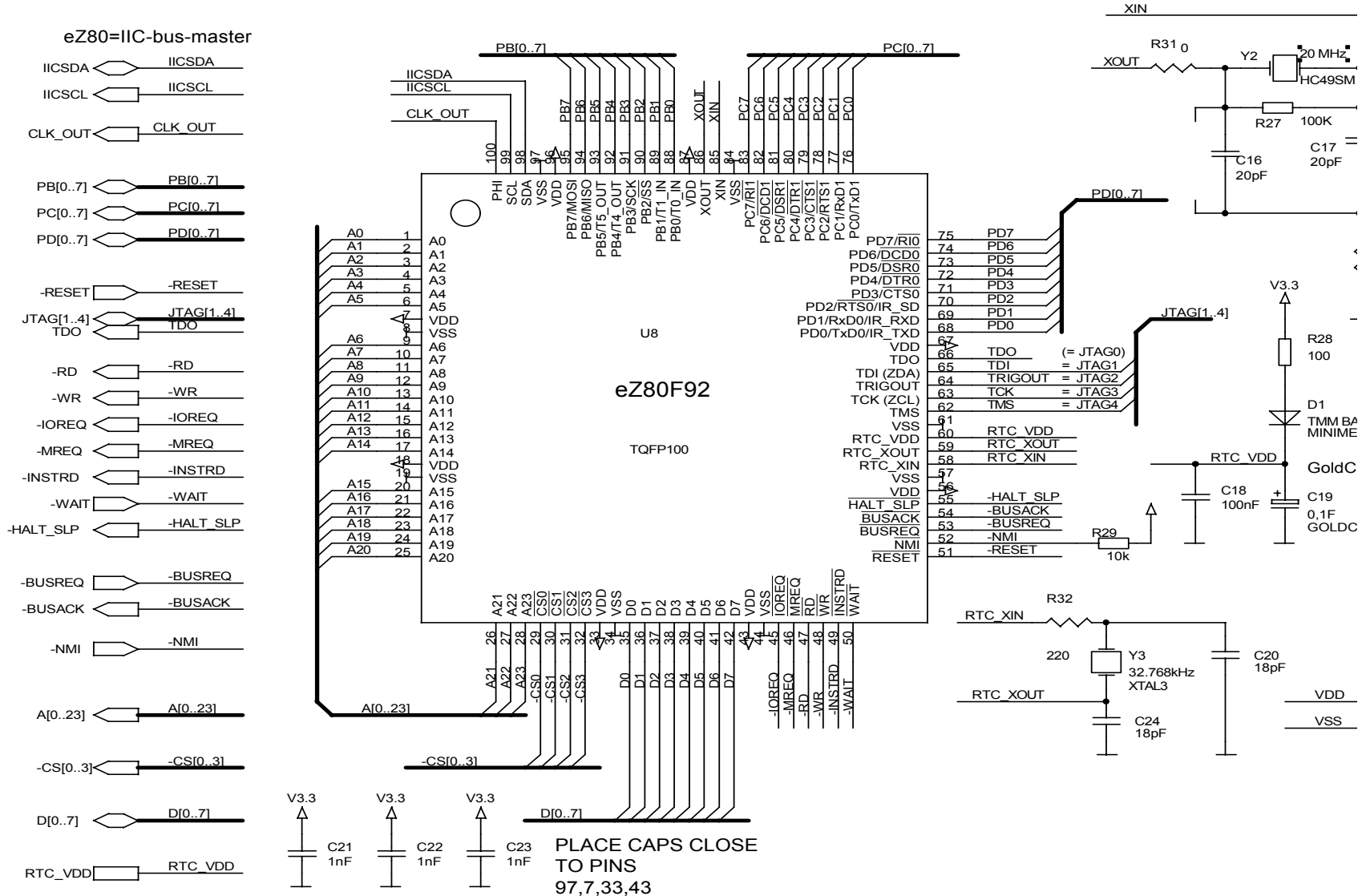
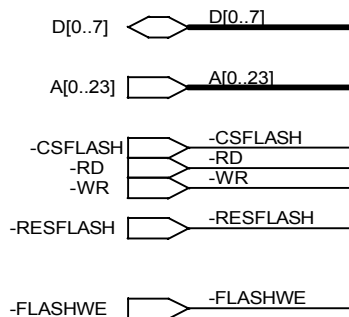
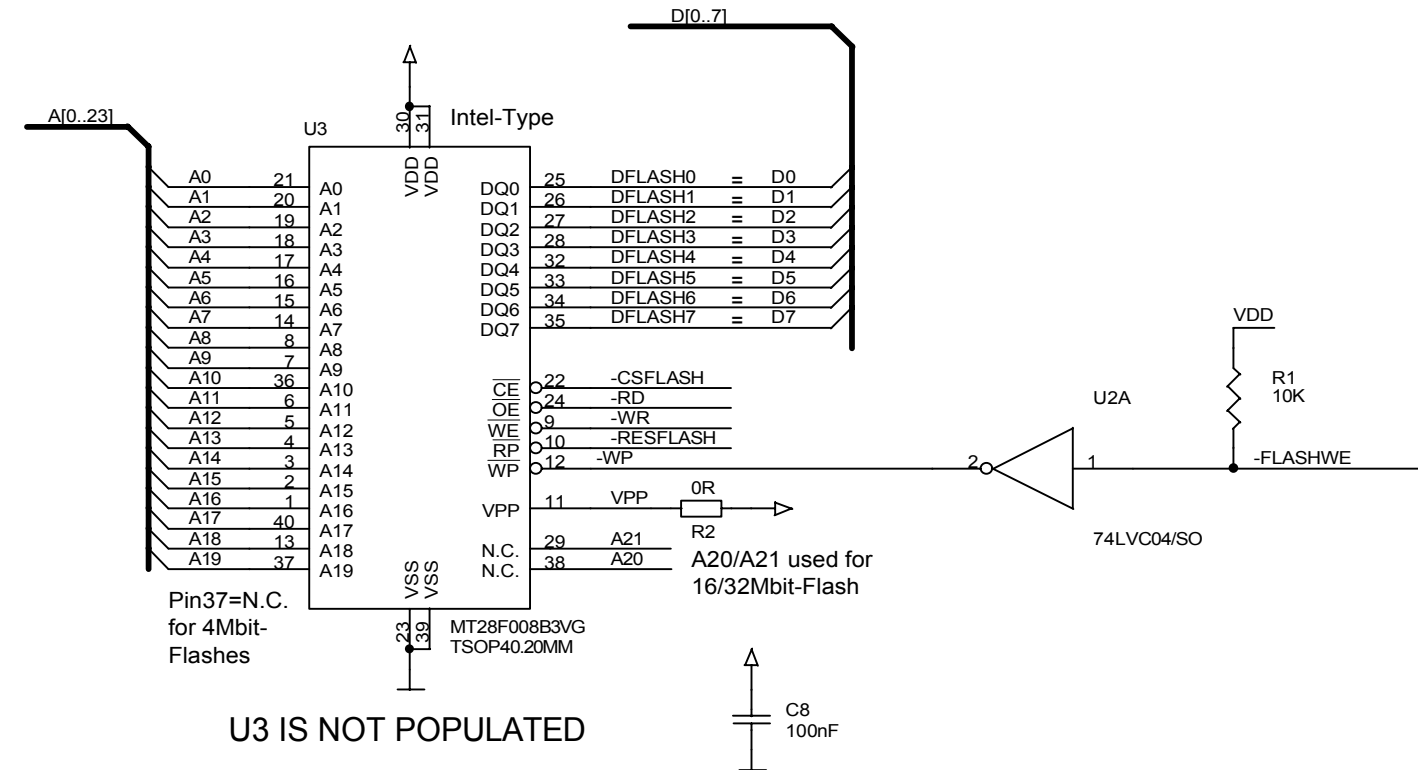

Figure 10. eZ80F92 Flash Module Schematics—100-Pin QFP eZ80F92 Device



Note: Must be pulled 'low' externally for programming.

Figure 12. eZ80F92 Flash Module Schematics—NOR Flash Device

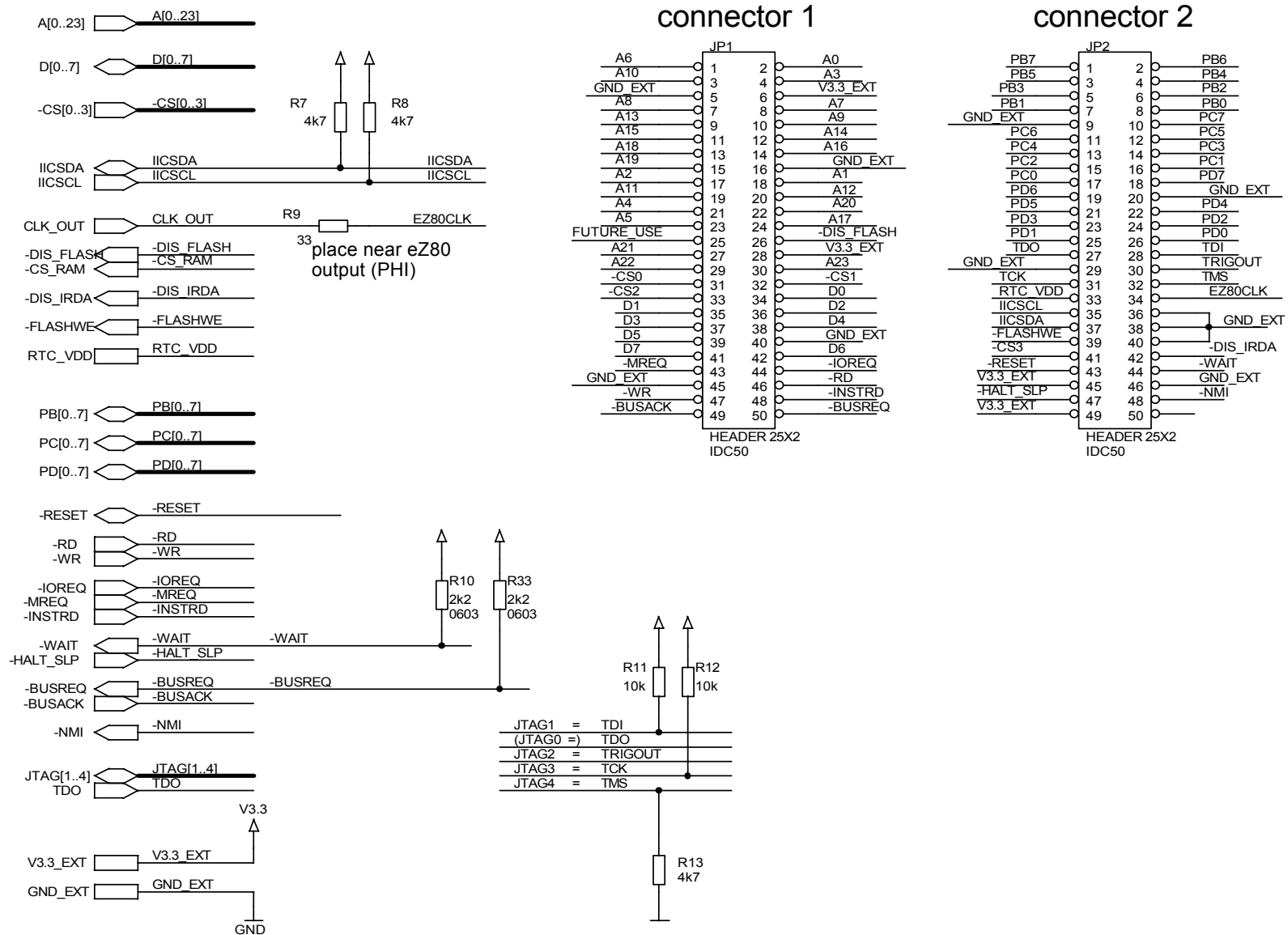

Figure 15. eZ80F92 Flash Module Schematics—Headers

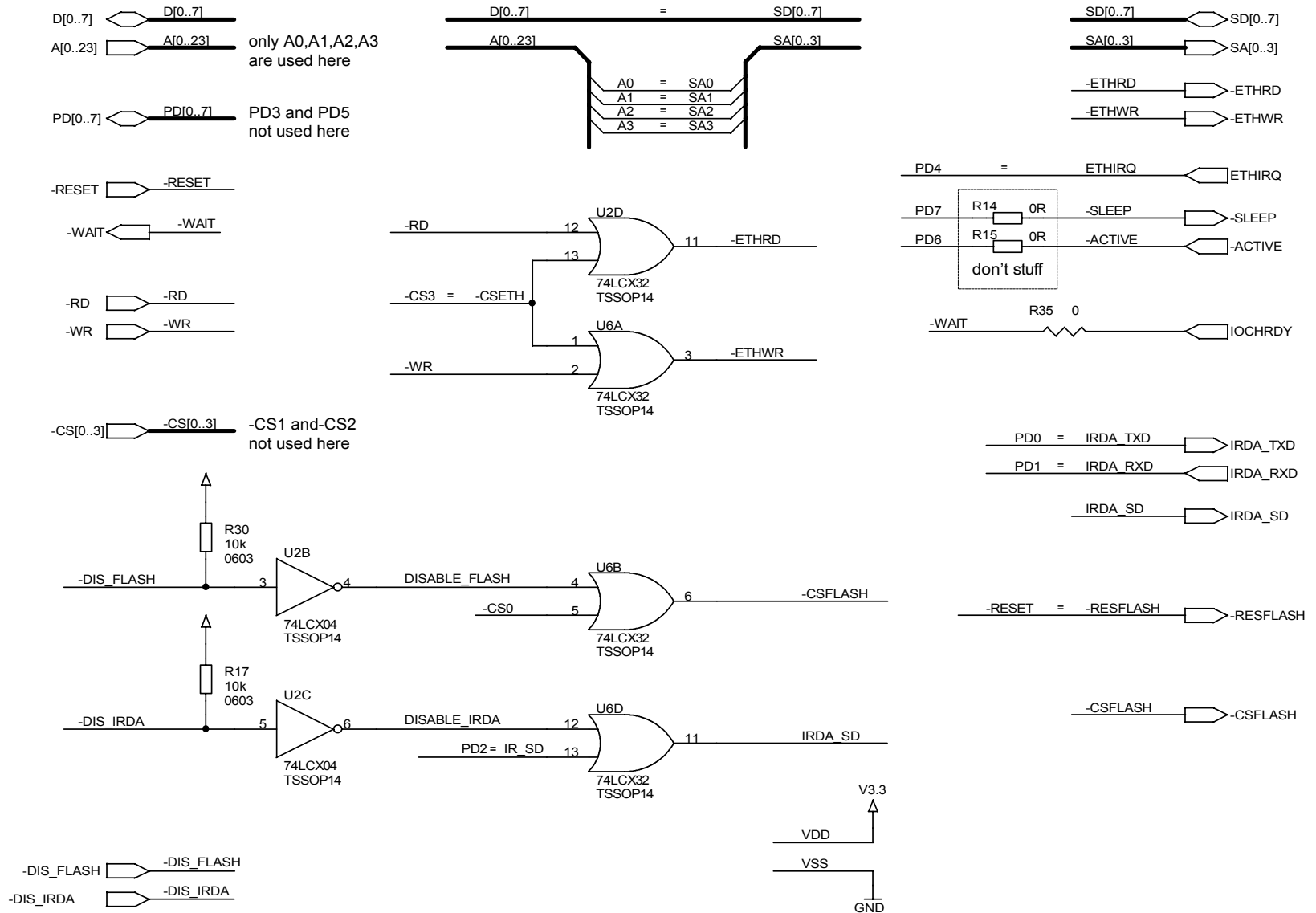

Figure 17. eZ80F92 Flash Module Schematics—Control Logic

Customer Support

For answers to technical questions about the product, documentation, or any other issues with Zilog's offerings, please visit Zilog's Knowledge Base at <http://www.zilog.com/kb>.

For any comments, detail technical questions, or reporting problems, please visit Zilog's Technical Support at <http://support.zilog.com>.